



Precision, Quad, SPST Analog Switches

General Description

The MAX361/MAX362 are precision, quad, single-pole single-throw (SPST) analog switches. The MAX361 has four normally closed (NC) switches, and the MAX362 has four normally open (NO) switches. Both parts offer low channel on resistance (less than 85Ω), guaranteed to match within 3Ω between channels and to remain flat over the analog signal range (Δ9Ω max). Both parts also offer low leakage (less than 500pA at +25°C and less than 4nA at +85°C) and fast switching (turn-on time less than 250ns and turn-off time less than 170ns).

The MAX361/MAX362 are fabricated with Maxim's new improved 44V silicon-gate process. Design improvements guarantee extremely low charge injection (10pC), low power consumption (35μW), and electrostatic discharge (ESD) greater than 2000V. The 44V maximum breakdown voltage allows rail-to-rail analog signal handling capability.

These monolithic switches operate with a single positive supply (+10V to +30V) or with split supplies (±4.5V to ±20V) while retaining CMOS-logic input compatibility and fast switching. CMOS inputs provide reduced input loading.

Applications

- Sample-and-Hold Circuits
- Guidance and Control Systems
- Heads-Up Displays
- Test Equipment
- Communications Systems
- Battery-Operated Systems
- PBX, PABX

Features

- ◆ **Low On Resistance:** < 45Ω Typical (85Ω Max)
- ◆ **Guaranteed Matched On Resistance Between Channels:** < 2Ω
- ◆ **Guaranteed Flat On Resistance over Analog Signal Range:** Δ9Ω Max
- ◆ **Guaranteed Charge Injection:** < 10pC
- ◆ **Guaranteed Off-Channel Leakage:** <4nA at +85°C
- ◆ **ESD Guaranteed > 2000V per Method 3015.7**
- ◆ **Single-Supply Operation (+10V to +30V)**
Bipolar-Supply Operation (±4.5V to ±20V)
- ◆ **TTL-/CMOS-Logic Compatible**
- ◆ **Rail-to-Rail Analog Signal Handling Capability**

Ordering Information

PART	TEMP. RANGE	PIN-PACKAGE
MAX361 CPE	0°C to +70°C	16 Plastic DIP
MAX361CSE	0°C to +70°C	16 Narrow SO
MAX361C/D	0°C to +70°C	Dice*
MAX361EPE	-40°C to +85°C	16 Plastic DIP
MAX361ESE	-40°C to +85°C	16 Narrow SO
MAX361EJE	-40°C to +85°C	16 CERDIP
MAX361MJE	-55°C to +125°C	16 CERDIP
MAX362 CPE	0°C to +70°C	16 Plastic DIP
MAX362CSE	0°C to +70°C	16 Narrow SO
MAX362C/D	0°C to +70°C	Dice*
MAX362EPE	-40°C to +85°C	16 Plastic DIP
MAX362ESE	-40°C to +85°C	16 Narrow SO
MAX362EJE	-40°C to +85°C	16 CERDIP
MAX362MJE	-55°C to +125°C	16 CERDIP

* Contact factory for dice specifications.

Pin Configurations/Functional Diagrams/Truth Tables

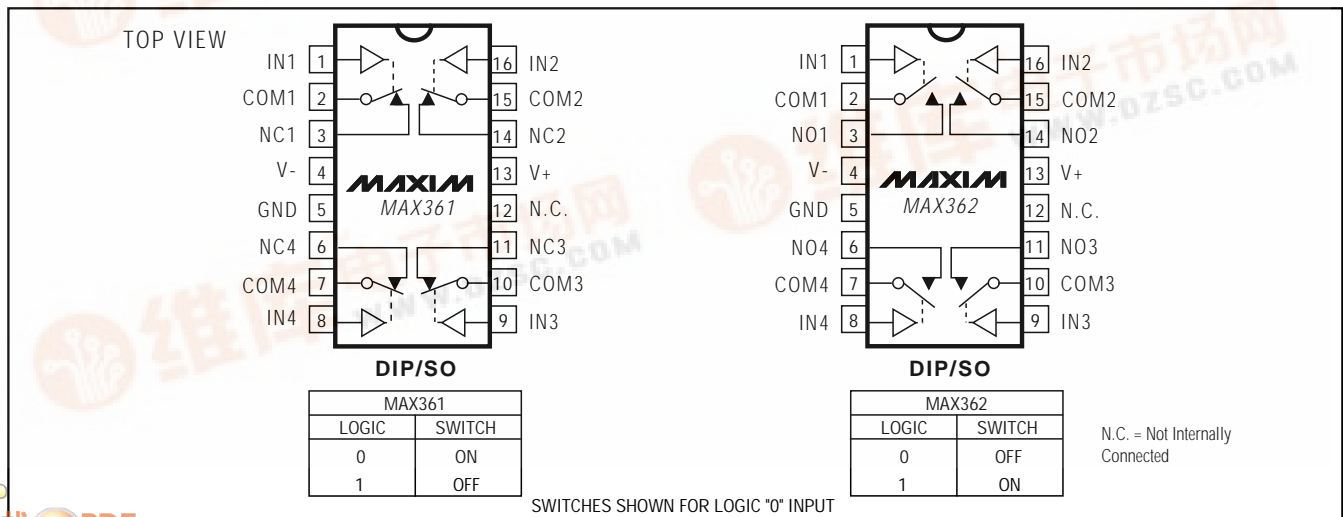

MAX361/MAX362

Precision, Quad, SPST Analog Switches

ABSOLUTE MAXIMUM RATINGS

Voltage Referenced to V-

V+	44V
GND	25V
IN_, COM_, NO_, NC_	(V- - 2V) to (V+ + 2V) or 30mA (whichever occurs first)

Continuous Current (any terminal)30mA
 Peak Current COM, NO, NC
 (pulsed at 1ms, 10% duty cycle max).....100mA
 ESD.....2000V

Continuous Power Dissipation (T_A = +70°C) (Note 1)

Plastic DIP (derate 10.53mW/°C above +70°C).....	842mW
Narrow SO (derate 8.70mW/°C above +70°C).....	696mW
CERDIP (derate 10.00mW/°C above +70°C)	800mW

Operating Temperature Ranges:

MAX36_C_	0°C to +70°C
MAX36_E_	-40°C to +85°C
MAX36_MJE	-55°C to +125°C

Storage Temperature Range-65°C to +150°C
 Lead Temperature (soldering, 10sec)+300°C

Note 1: All leads are soldered or welded to PC board.

Stresses beyond those listed under "Absolute Maximum Ratings" may cause permanent damage to the device. These are stress ratings only, and functional operation of the device at these or any other conditions beyond those indicated in the operational sections of the specifications is not implied. Exposure to absolute maximum rating conditions for extended periods may affect device reliability.

ELECTRICAL CHARACTERISTICS—Dual Supplies

(V+ = 15V, V- = -15V, GND = 0V, V_{INH} = 2.4V, V_{INL} = 0.8V, T_A = T_{MIN} to T_{MAX}, unless otherwise noted.)

PARAMETER	SYMBOL	CONDITIONS	MIN	TYP (Note 2)	MAX	UNITS		
ANALOG								
Analog-Signal Range	V _{COM_} , V _{NO_} , V _{NC_}	(Note 3)	-15		15	V		
On Resistance (COM_ to NO_ or COM_ to NC_ terminals)	R _{ON}	I _(NO or NC) = -10mA, V _{COM_} = 8.5V or -8.5V, V+ = 13.5V, V- = -13.5V	T _A = +25°C		50	85	Ω	
			T _A = T _{MIN} to T _{MAX}			100		
On Resistance Match Between Channels (Note 4)	R _{ON}	I _(NO or NC) = -10mA, V _{COM_} = 10V or -10V, V+ = 15V, V- = -15V	T _A = +25°C			2	Ω	
			T _A = T _{MIN} to T _{MAX}			4		
On Resistance Flatness (Note 4)	R _{ON}	I _(NO or NC) = -10mA, V _{COM_} = 5V or -5V, V+ = 15V, V- = -15V	T _A = +25°C			9	Ω	
			T _A = T _{MIN} to T _{MAX}			15		
Off Leakage Current (NO_ or NC_ terminal)	I _{NO_} , I _{NC_}	V _{COM_} = ±15.5V, V _{NC_} or V _{NO_} = ∓15.5V, V+ = 16.5V, V- = -16.5V	T _A = +25°C		-0.50	0.01	0.50	nA
			T _A = T _{MAX}	C, E	-4	4		
				M	-20	20		
Off Leakage Current (COM_ terminal)	I _{COM}	V _{NC_} or V _{NO_} = ±15.5V, V _{COM_} = ∓15.5V, V+ = 16.5V, V- = -16.5V	T _A = +25°C		-0.50	0.01	0.50	nA
			T _A = T _{MAX}	C, E	-4	4		
				M	-20	20		
On Leakage Current (COM_ and NC_ or NO_ terminal)	I _{COM} or I _{NO_} , I _{NC_}	V _{COM_} = ±15.5V, V _{NC_} or V _{NO_} = ±15.5V, V+ = 16.5V, V- = -16.5V	T _A = +25°C		-0.50	0.08	0.50	nA
			T _A = T _{MAX}	C, E	-6	6		
				M	-40	40		
DIGITAL								
Input Current with Input Voltage High	I _{INH}	V _{INL} = 2.4V	-500	0.01	500	nA		
Input Current with Input Voltage Low	I _{INH}	V _{INL} = 0.8V	-500	0.01	500	nA		

Precision, Quad, SPST Analog Switches

MAX361/MAX362

ELECTRICAL CHARACTERISTICS—Dual Supplies (continued)

(V₊ = 15V, V₋ = -15V, GND = 0V, V_{INH} = 2.4V, V_{INL} = 0.8V, T_A = T_{MIN} to T_{MAX}, unless otherwise noted.)

PARAMETER	SYMBOL	CONDITIONS	MIN	TYP (Note 2)	MAX	UNITS	
SUPPLY							
Power-Supply Range	V ₊ , V ₋		±4.5		±20.0	V	
Positive Supply Current	I ₊	All channels on or off, V _{IN} = 0V or 5V, V ₊ = 16.5V, V ₋ = -16.5V		15	100	μA	
Negative Supply Current	I ₋	All channels on or off, V _{IN} = 0V or 5V, V ₊ = 16.5V, V ₋ = -16.5V	T _A = +25°C	-1	-0.0001	1	μA
			T _A = T _{MIN} to T _{MAX}	-5		5	
Ground Current	I _{GND}	All channels on or off, V _{IN} = 0V or 5V, V ₊ = 16.5V, V ₋ = -16.5V	-100	-15		μA	
DYNAMIC							
Turn-On Time	t _{ON}	Figure 1, V _S = ±10V, R _L = 1kΩ		150	250	ns	
Turn-Off Time	t _{OFF}	MAX361, Figure 1, V _{COM} = ±10V		90	120	ns	
		MAX362, Figure 1, V _{COM} = ±10V		110	170	ns	
Charge Injection	Q	C _L = 1nF, V _{GEN} = 0V, R _{GEN} = 0Ω, Figure 2		5	10	pC	
Off Isolation (Note 5)	OIRR	R _L = 50Ω, C _L = 5pF, f = 1MHz, Figure 3		60		dB	
Crosstalk (Note 6)		R _L = 50Ω, C _L = 5pF, f = 1MHz, Figure 4		-100		dB	
Off Capacitance NC or NO	C _(OFF)	f = 1MHz, Figure 5		4		pF	
Off Capacitance COM ₋	C _{COM(OFF)}	f = 1MHz, Figure 5		4		pF	
Channel-On Capacitance	C _{COM(ON)}	f = 1MHz, Figure 5		16		pF	

Precision, Quad, SPST Analog Switches

ELECTRICAL CHARACTERISTICS—Single Supply

(V₊ = 12V, V₋ = 0V, GND = 0V, V_{INH} = 2.4V, V_{INL} = 0.8V, T_A = T_{MIN} to T_{MAX}, unless otherwise noted.)

PARAMETER	SYMBOL	CONDITIONS	MIN	TYP (Note 2)	MAX	UNITS		
SWITCH								
Analog-Signal Range	V _{COM_} , V _{NO_} , V _{NC_}	(Note 3)	0		12	V		
On Resistance (COM_ to NO_ or COM_ to NC_ terminals)	R _{ON}	I _(NC or NO) = 1.0mA, V _{COM_} = 3V, 8V, V ₊ = 10.8V	T _A = +25°C		100	160	Ω	
			T _A = T _{MIN} to T _{MAX}		200			
SUPPLY								
Power-Supply Range	V ₊		10		30	V		
Positive Supply Current	I ₊	All channels on or off, V _{IN} = 0V or 5V		15	100	μA		
Negative Supply Current	I ₋	All channels on or off, V _{IN} = 0V or 5V	T _A = +25°C		-1	-0.0001	1	μA
			T _A = T _{MIN} to T _{MAX}		-5		+5	
Ground Current	I _{GND}	All channels on or off, V _{IN} = 0V or 5V	-100	-15				
DYNAMIC								
Turn-On Time	t _{ON}	Figure 1, V _S = 8V			300	400	ns	
Turn-Off Time	t _{OFF}	Figure 1, V _S = 8V			60	200	ns	
Charge Injection	Q	C _L = 1nF, V _{GEN} = 0V,			5	10	pC	

Note 2: The algebraic convention, where the most negative value is a minimum and the most positive value a maximum, is used in this data sheet.

Note 3: Guaranteed by design.

Note 4: On resistance match between channels and flatness are guaranteed only with bipolar-supply operation.

Note 5: See Figure 3. Off Isolation = $20 \log_{10} \left(\frac{V_{COM}}{V_{NC-} \text{ or } V_{NO-}} \right)$, V_{COM} = output, V_{NC-} or V_{NO-} = input to off switch.

Note 6: Between any two switches. See Figure 4.

Precision, Quad, SPST Analog Switches

Typical Operating Characteristics

($T_A = +25^\circ\text{C}$, unless otherwise noted.)

MAX361/MAX362

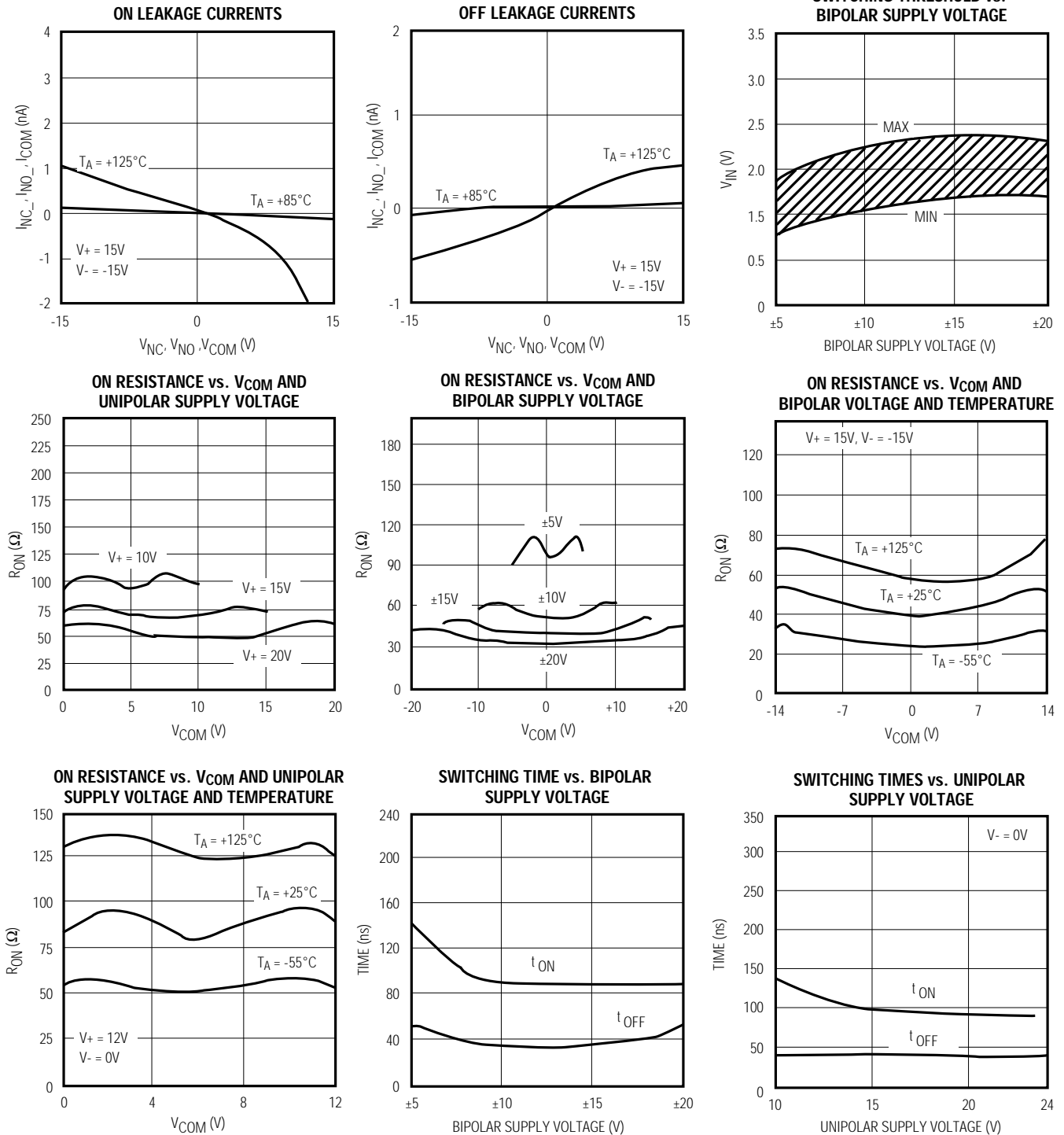

Precision, Quad, SPST Analog Switches

Typical Operating Characteristics (continued)

($T_A = +25^\circ\text{C}$, unless otherwise noted.)

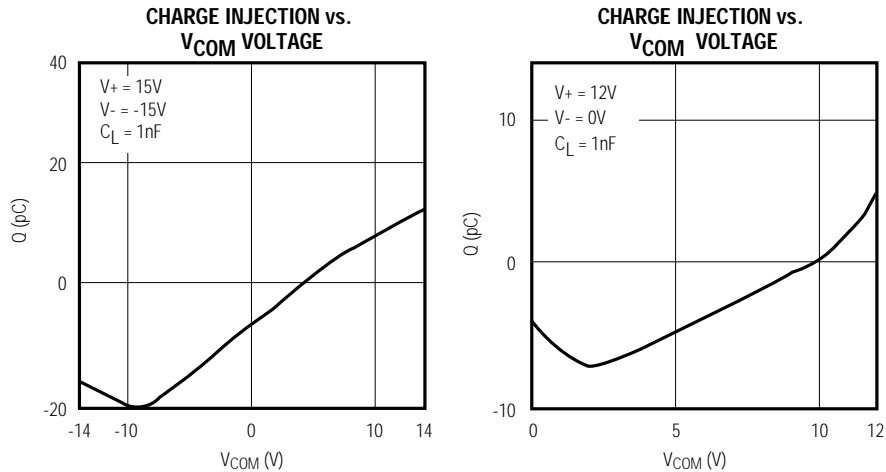

Pin Description

PIN	NAME		FUNCTION
	MAX361	MAX362	
1, 16, 9, 8	IN1-IN4	IN1-IN4	Logic-level input
2, 15, 10, 7	COM1-COM4	COM1-COM4	Analog switch common terminal
3, 14, 11, 6	NC1-NC4	NO1-NO4	NC (normally closed, MAX361) NO (normally open, MAX362) Analog switch terminal
4	V-	V-	Negative supply voltage input
5	GND	GND	Ground
12	N.C.	N.C.	Not internally connected
13	V+	V+	Positive supply voltage input—connected to substrate.

Applications Information

Operation with Supply Voltages Other Than $\pm 15V_O$

Using supply voltages other than $\pm 15\text{V}$ reduces the analog signal range. The MAX361/MAX362 switches operate with bipolar supplies of $\pm 4.5\text{V}$ to $\pm 20\text{V}$. Typical operating characteristic graphs show typical on resistance for $\pm 15\text{V}$, $\pm 10\text{V}$, and $\pm 5\text{V}$ supplies. Switching times increase by a factor of two or more for $\pm 5\text{V}$ operation. The MAX361/MAX362 can also operate from $+10\text{V}$ to $+30\text{V}$ unipolar supplies. Both parts can also be powered from unbalanced supplies such as $+24\text{V}$ and -5V . Connect V- to 0V when operating with a single supply.

Proper power-supply sequencing is recommended for all CMOS devices. Do not exceed the absolute maximum ratings, because stresses beyond the listed ratings may cause permanent damage to the devices. Always sequence V+ on first, followed by V-, and logic inputs. If power-supply sequencing is not possible, add two small signal diodes in series with the supply pins for overvoltage protection (Figure 6). Adding the diodes reduces the analog signal range to 1V below V+ and 1V below V-, but low switch resistance and low leakage characteristics are unaffected. Device operation is unchanged, and the difference from V+ to V- should not exceed $+44\text{V}$.

Precision, Quad, SPST Analog Switches

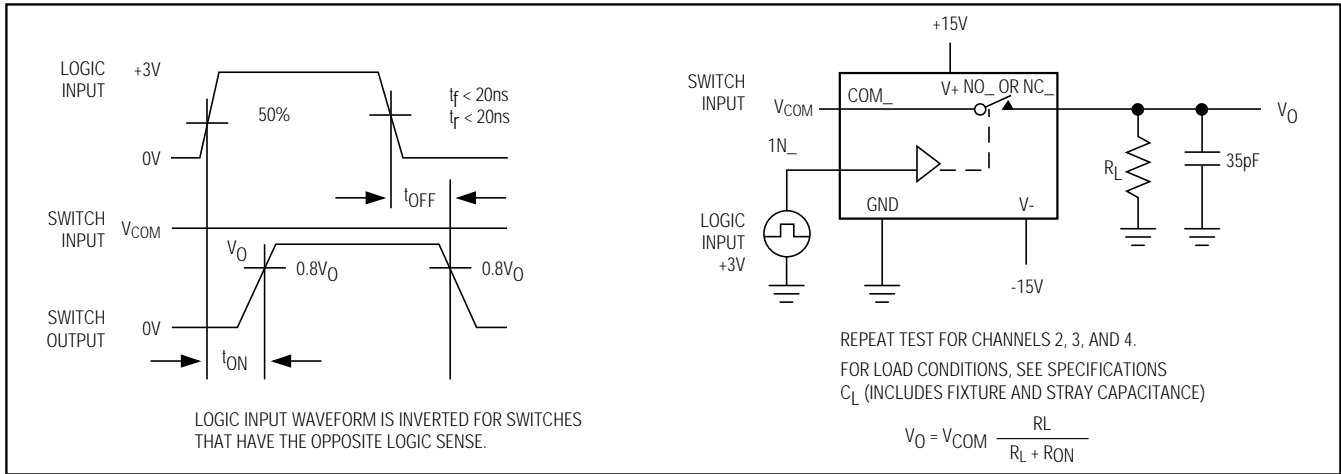

Figure 1. Switching-Time Test Circuit

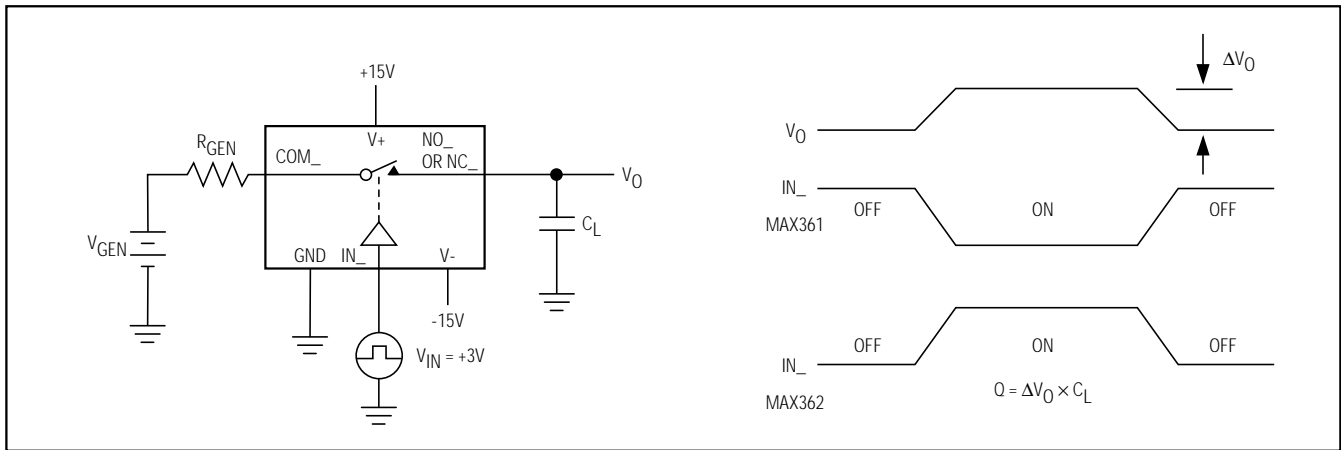

Figure 2. Charge-Injection Test Circuit

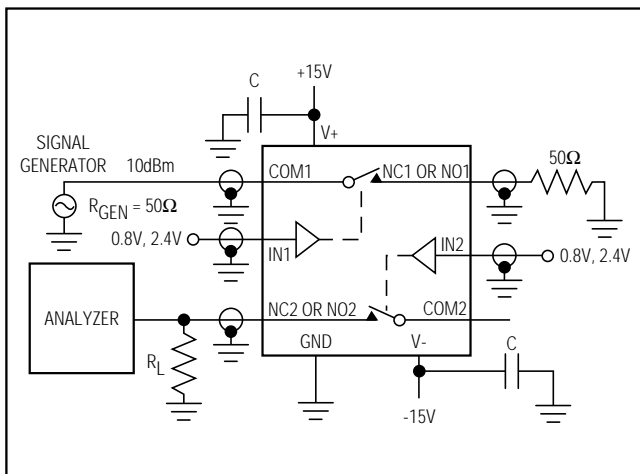

Figure 3. Crosstalk Test Circuit (repeat for channels 3 and 4)

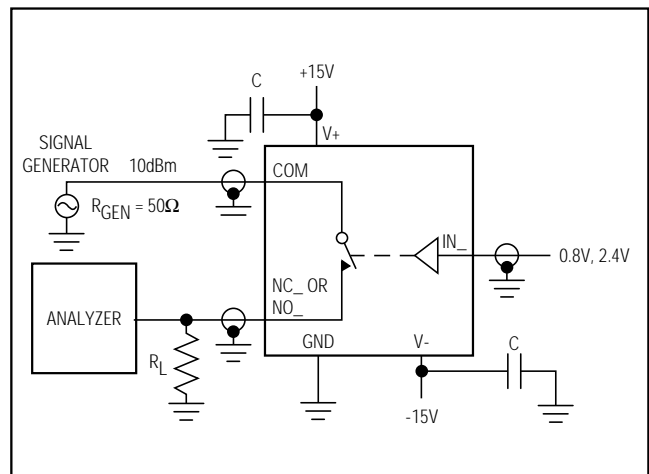

Figure 4. Off-Isolation Test Circuit

Precision, Quad, SPST Analog Switches

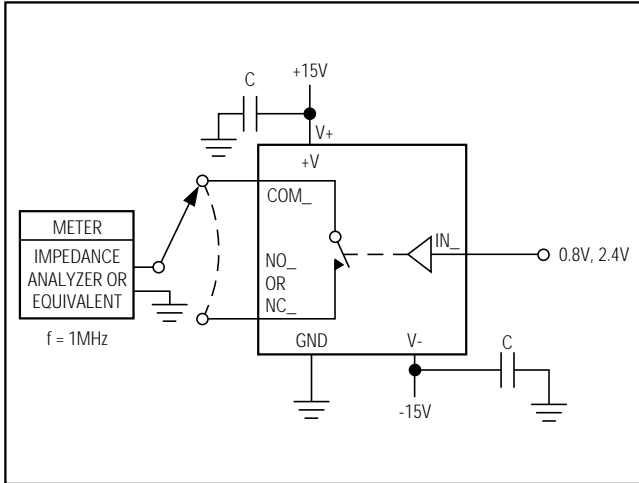

Figure 5. Channel Capacitance Test Circuit

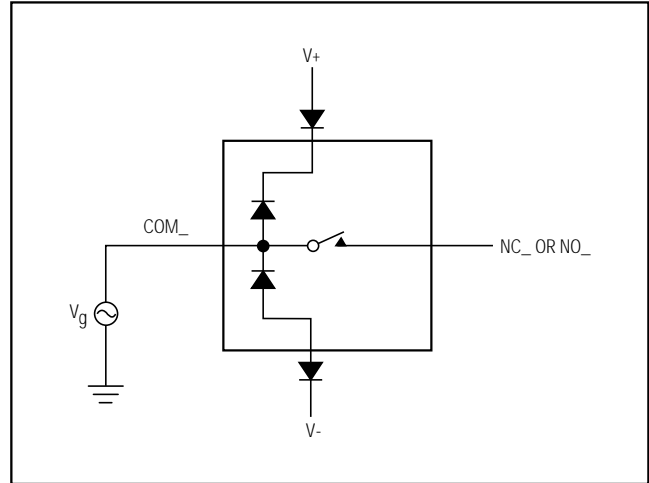
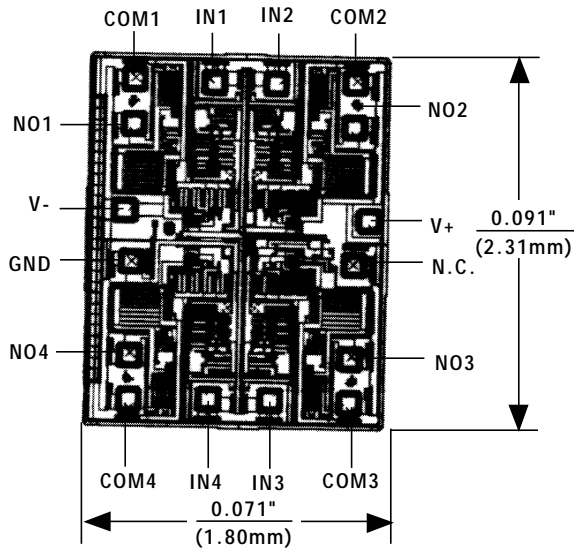

Figure 6. Overvoltage Protection Using Blocking Diodes

Chip Topography



TRANSISTOR COUNT: 126;
 SUBSTRATE CONNECTED TO V+.

Maxim cannot assume responsibility for use of any circuitry other than circuitry entirely embodied in a Maxim product. No circuit patent licenses are implied. Maxim reserves the right to change the circuitry and specifications without notice at any time.

8 Maxim Integrated Products, 120 San Gabriel Drive, Sunnyvale, CA 94086 (408) 737-7600