

MAXIM

2.5Ω, Dual, SPST, CMOS Analog Switches

General Description

The MAX4607/MAX4608/MAX4609 dual analog switches feature low on-resistance of 2.5Ω max. On-resistance is matched between switches to 0.5Ω max and is flat (0.5Ω max) over the specified signal range. Each switch can handle Rail-to-Rail® analog signals. The off-leakage current is only 2.5nA max at +85°C. These analog switches are ideal in low-distortion applications and are the preferred solution over mechanical relays in automatic test equipment or applications where current switching is required. They have low power requirements, require less board space, and are more reliable than mechanical relays.

The MAX4607 has two normally closed (NC) switches, the MAX4608 has two normally open (NO) switches, and the MAX4609 has one NC and one NO switch.

These switches operate from a single supply of +4.5V to +36V or from dual supplies of ±4.5V to ±20V. All digital inputs have +0.8V and +2.4V logic thresholds, ensuring TTL/CMOS-logic compatibility when using dual ±15V or a single +12V supply.

Applications

Reed Relay Replacement	PBX, PABX Systems
Test Equipment	Audio-Signal Routing
Communication Systems	Avionics

Features

- ◆ Low On-Resistance (2.5Ω max)
- ◆ Guaranteed R_{ON} Match Between Channels (0.5Ω max)
- ◆ Guaranteed R_{ON} Flatness over Specified Signal Range (0.5Ω max)
- ◆ Rail-to-Rail Signal Handling
- ◆ Guaranteed ESD Protection > 2kV per Method 3015.7
- ◆ Single-Supply Operation: +4.5V to +36V
Dual-Supply Operation: ±4.5V to ±20V
- ◆ TTL/CMOS-Compatible Control Inputs

Ordering Information

PART	TEMP. RANGE	PIN-PACKAGE
MAX4607CSE	0°C to +70°C	16 Narrow SO
MAX4607CPE	0°C to +70°C	16 Plastic DIP
MAX4607ESE	-40°C to +85°C	16 Narrow SO
MAX4607EPE	-40°C to +85°C	16 Plastic DIP

Ordering information continued at end of data sheet.

Pin Configurations/Functional Diagrams/Truth Tables

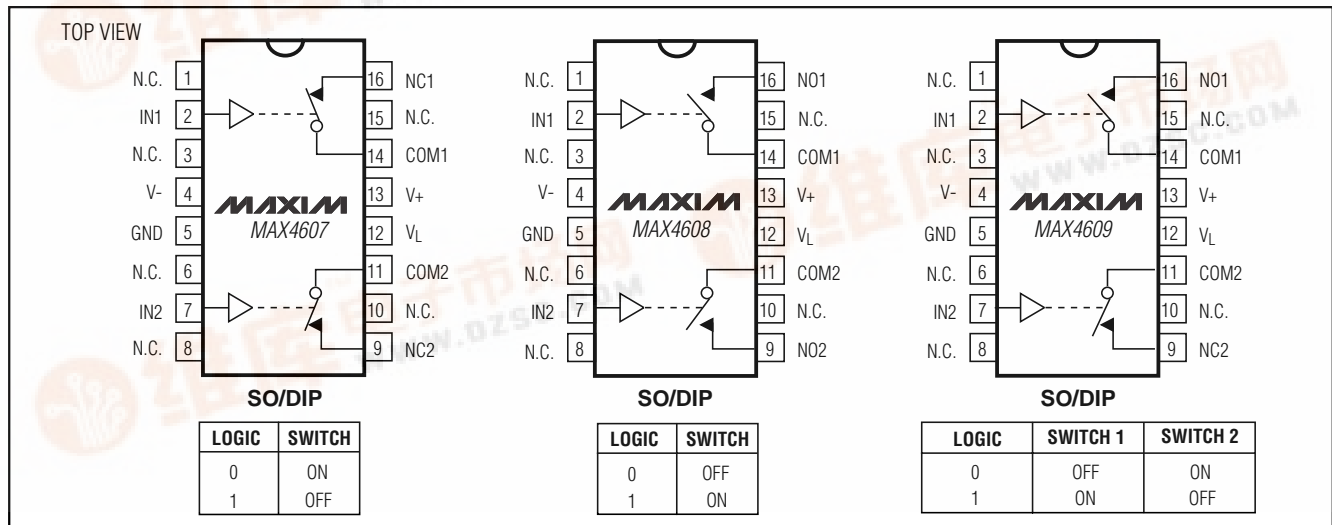

Rail-to-Rail is a registered trademark of Nippon Motorola, Ltd.

2.5Ω, Dual, SPST, CMOS Analog Switches

ABSOLUTE MAXIMUM RATINGS

V+ to GND	-0.3V to +44V
V- to GND	+0.3V to -44V
V+ to V-	-0.3V to +44V
V _L to GND	(GND - 0.3V) to (V+ + 0.3V)
All Other Pins to GND (Note 1)	(V- - 0.3V) to (V+ + 0.3V)
Continuous Current (COM ₋ , NO ₋ , NC ₋)	±100mA
Peak Current (COM ₋ , NO ₋ , NC ₋) (pulsed at 1ms, 10% duty cycle)	±300mA

Continuous Power Dissipation (T _A = +70°C)	
Narrow SO (derate 8.70mW/°C above +70°C)	696mW
Plastic DIP (derate 10.53mW/°C above +70°C)	842mW
Operating Temperature Ranges	
MAX460_C_E	0°C to +70°C
MAX460_E_E	-40°C to +85 °C
Storage Temperature Range	-65°C to +160°C
Lead Temperature (soldering, 10sec)	+300°C

Note 1: Signals on NC₋, NO₋, COM₋, or IN₋, exceeding V+ or V- will be clamped by internal diodes. Limit forward diode current to maximum current rating.

Stresses beyond those listed under "Absolute Maximum Ratings" may cause permanent damage to the device. These are stress ratings only, and functional operation of the device at these or any other conditions beyond those indicated in the operational sections of the specifications is not implied. Exposure to absolute maximum rating conditions for extended periods may affect device reliability.

ELECTRICAL CHARACTERISTICS—Dual Supplies

(V+ = +15V, V- = -15V, V_L = +5V, V_{IN_H} = +2.4V, V_{IN_L} = +0.8V, T_A = T_{MIN} to T_{MAX}, unless otherwise noted. Typical values are at T_A = +25°C.) (Note 2)

PARAMETER	SYMBOL	CONDITIONS	MIN	TYP	MAX	UNITS
ANALOG SWITCH						
Input Voltage Range (Note 3)	V _{COM_-} , V _{NO_-} , V _{NC_-}		V-		V+	V
COM ₋ to NO ₋ , COM ₋ to NC ₋ On-Resistance	R _{ON}	I _{COM_-} = 10mA, V _{NO_-} or V _{NC_-} = ±10V		1.6	2.5	Ω
		T _A = +25°C				
		T _A = T _{MIN} to T _{MAX}			3	
COM ₋ to NO ₋ , COM ₋ to NC ₋ On-Resistance Match Between Channels (Note 4)	ΔR _{ON}	I _{COM_-} = 10mA, V _{NO_-} or V _{NC_-} = -5V, 0, 5V		0.05	0.4	Ω
		T _A = T _{MIN} to T _{MAX}			0.5	
COM ₋ to NO ₋ , COM ₋ to NC ₋ On-Resistance Flatness (Note 5)	R _{FLAT(ON)}	I _{COM_-} = 10mA, V _{NO_-} or V _{NC_-} = ±10V		0.1	0.4	Ω
		T _A = T _{MIN} to T _{MAX}			0.5	
Off-Leakage Current (NO ₋ or NC ₋) (Note 6)	I _{NO_-} , I _{NC_-}	V _{COM_-} = ±10V, V _{NO_-} or V _{NC_-} = ∓10V		-0.5	0.01	nA
		T _A = T _{MIN} to T _{MAX}		-2.5	2.5	
COM Off-Leakage Current (Note 6)	I _{COM_(OFF)}	V _{COM_-} = ±10V, V _{NO_-} or V _{NC_-} = ∓10V		-0.5	0.01	nA
		T _A = T _{MIN} to T _{MAX}		-2.5	2.5	
COM On-Leakage Current (Note 6)	I _{COM_(ON)}	V _{COM_-} = ±10V, V _{NO_-} or V _{NC_-} = ±10V, or floating		-1	0.02	nA
		T _A = T _{MIN} to T _{MAX}		-10	10	
LOGIC INPUT						
Input Current with Input Voltage High	I _{IN_H}	IN ₋ = 2.4V, all others = 0.8V	-0.500	0.001	0.500	μA
Input Current with Input Voltage Low	I _{IN_L}	IN ₋ = 0.8V, all others = 2.4V	-0.500	0.001	0.500	μA
Logic Input High Voltage	V _{IN_H}		2.4	1.7		V
Logic Input Low Voltage	V _{IN_L}			1.7	0.8	V

2.5Ω, Dual, SPST, CMOS Analog Switches

ELECTRICAL CHARACTERISTICS—Dual Supplies (continued)

(V+ = +15V, V- = -15V, VL = +5V, VIN_H = +2.4V, VIN_L = +0.8V, TA = TMIN to TMAX, unless otherwise noted. Typical values are at TA = +25°C.) (Note 2)

PARAMETER	SYMBOL	CONDITIONS	MIN	TYP	MAX	UNITS	
POWER SUPPLY							
Power-Supply Range			±4.5		±20.0	V	
Positive Supply Current	I+	VIN = 0 or 5V	TA = +25°C	-0.5	0.001	0.5	μA
			TA = TMIN to TMAX	5		5	
Negative Supply Current	I-	VIN = 0 or 5V	TA = +25°C	-0.5	0.001	0.5	μA
			TA = TMIN to TMAX	5		5	
Logic Supply Current	IL	VIN = 0 or 5V	TA = +25°C	-0.5	0.001	0.5	μA
			TA = TMIN to TMAX	5		5	
Ground Current	IGND	VIN = 0 or 5V	TA = +25°C	-0.5	0.001	0.5	μA
			TA = TMIN to TMAX	5		5	
SWITCH DYNAMIC CHARACTERISTICS							
Turn-On Time	tON	VCOM_ = ±10V, Figure 2, TA = +25°C		110		ns	
Turn-Off Time	tOFF	VCOM_ = ±10V, Figure 2, TA = +25°C		150		ns	
Charge Injection	Q	CL = 1.0nF, VGEN = 0, RGEN = 0, Figure 3, TA = +25°C		450		pC	
Off-Isolation (Note 7)	VISO	RL = 50Ω, CL = 5pF, f = 1MHz, Figure 4, TA = +25°C		-60		dB	
Crosstalk (Note 8)	VCT	RL = 50Ω, CL = 5pF, f = 1MHz, Figure 5, TA = +25°C		-66		dB	
NC_ or NO_ Capacitance	COFF	f = 1MHz, Figure 6, TA = +25°C		65		pF	
COM_ Off-Capacitance	CCOM	f = 1MHz, Figure 6, TA = +25°C		65		pF	
On-Capacitance	CCOM	f = 1MHz, Figure 7, TA = +25°C		290		pF	

MAX4607/MAX4608/MAX4609

2.5Ω, Dual, SPST, CMOS Analog Switches

ELECTRICAL CHARACTERISTICS—Single Supply

(V₊ = +12V, V₋ = 0, V_L = +5V, V_{IN_H} = +2.4V, V_{IN_L} = +0.8V, T_A = T_{MIN} to T_{MAX}, unless otherwise noted. Typical values are at T_A = +25°C.) (Note 2)

PARAMETER	SYMBOL	CONDITIONS		MIN	TYP	MAX	UNITS
ANALOG SWITCH							
Input Voltage Range (Note 3)	V _{COM_} , V _{NO_} , V _{NC_}			GND		V ₊	V
COM ₋ to NO ₋ , COM ₋ to NC ₋ On-Resistance	R _{ON}	I _{COM_} = 10mA, V _{NO_} or V _{NC_} = 10V	T _A = +25°C T _A = T _{MIN} to T _{MAX}		3 6	7	Ω
COM ₋ to NO ₋ , COM ₋ to NC ₋ On-Resistance Match Between Channels (Note 4)	ΔR _{ON}	I _{COM_} = 10mA, V _{NO_} or V _{NC_} = 10V	T _A = +25°C T _A = T _{MIN} to T _{MAX}		0.05	0.4 0.5	Ω
COM ₋ to NO ₋ , COM ₋ to NC ₋ On-Resistance Flatness (Note 5)	R _{FLAT(ON)}	I _{COM_} = 10mA, V _{NO_} or V _{NC_} = 3V, 6V, 0V	T _A = +25°C T _A = T _{MIN} to T _{MAX}		0.05	0.5 0.5	Ω
Off-Leakage Current (NO ₋ or NC ₋) (Notes 6, 9)	I _{NO_} I _{NC_}	V _{COM_} = 1V, 10V, V _{NO_} or V _{NC_} = 1V, 10V	T _A = +25°C T _A = T _{MIN} to T _{MAX}	-0.5 -2.5	0.01	0.5 2.5	nA
COM Off-Leakage Current (Notes 6, 9)	I _{COM_(OFF)}	V _{COM_} = 10V, 1V V _{NO_} or V _{NC_} = 1V, 10V	T _A = +25°C T _A = T _{MIN} to T _{MAX}	-0.5 -2.5	0.01	0.5 2.5	nA
COM On-Leakage Current (Notes 6, 9)	I _{COM_(ON)}	V _{COM_} = 1V, 10V, V _{NO_} or V _{NC_} = 1V, 10V, or floating	T _A = +25°C T _A = T _{MIN} to T _{MAX}	-1 -10	0.01	1 10	nA
LOGIC INPUT							
Input Current with Input Voltage High	I _{IN_H}	I _{N_} = 2.4V, all others = 0.8V		-0.500	0.001	0.500	μA
Input Current with Input Voltage Low	I _{IN_L}	I _{N_} = 0.8V, all others = 2.4V		-0.500	0.001	0.500	μA
Logic Input High Voltage	V _{IN_H}			2.4	1.7		V
Logic Input Low Voltage	V _{IN_L}				1.7	0.8	V

2.5Ω, Dual, SPST, CMOS Analog Switches

MAX4607/MAX4608/MAX4609

ELECTRICAL CHARACTERISTICS—Single Supply (continued)

(V₊ = +12V, V₋ = 0, V_L = +5V, V_{IN_H} = +2.4V, V_{IN_L} = +0.8V, T_A = T_{MIN} to T_{MAX}, unless otherwise noted. Typical values are at T_A = +25°C.) (Note 2)

PARAMETER	SYMBOL	CONDITIONS		MIN	TYP	MAX	UNITS
POWER SUPPLY							
Power-Supply Range				+4.5		+36.0	V
Positive Supply Current	I ₊	V _{IN} = 0 or 5V	T _A = +25°C	-0.5	0.001	0.5	μA
			T _A = T _{MIN} to T _{MAX}	5		5	
Logic Supply Current	I _L	V _{IN} = 0 or 5V	T _A = +25°C	-0.5	0.001	0.5	μA
			T _A = T _{MIN} to T _{MAX}	5		5	
Ground Current	I _{GND}	V _{IN} = 0 or 5V	T _A = +25°C	-0.5	0.001	0.5	μA
			T _A = T _{MIN} to T _{MAX}	5		5	
SWITCH DYNAMIC CHARACTERISTICS							
Turn-On Time	t _{ON}	V _{COM_} = 10V, Figure 2, T _A = +25°C			110		ns
Turn-Off Time	t _{OFF}	V _{COM_} = 10V, Figure 2, T _A = +25°C			130		ns
Charge Injection	Q	C _L = 1.0nF, V _{GEN} = 0, R _{GEN} = 0, Figure 3, T _A = +25°C			50		pC
Crosstalk (Note 8)	V _{CT}	R _L = 50Ω, C _L = 5pF, f = 1MHz, Figure 5, T _A = +25°C			66		dB
NC or NO Capacitance	C _(OFF)	f = 1MHz, Figure 6, T _A = +25°C			105		pF
COM Off-Capacitance	C _(COM)	f = 1MHz, Figure 6, T _A = +25°C			105		pF
On-Capacitance	C _(COM)	f = 1MHz, Figure 7, T _A = +25°C			185		pF

Note 2: The algebraic convention, where the most negative value is a minimum and the most positive value a maximum, is used in this data sheet.

Note 3: Guaranteed by design.

Note 4: ΔR_{ON} = R_{ON(MAX)} - R_{ON(MIN)}

Note 5: Flatness is defined as the difference between the maximum and minimum value of on-resistance as measured over the specified analog signal range.

Note 6: Leakage parameters are 100% tested at maximum-rated hot temperature and guaranteed by correlation at +25°C.

Note 7: Off-isolation = 20log₁₀ [V_{COM} / (V_{NC} or V_{NO})], V_{COM} = output, V_{NC} or V_{NO} = input to off switch.

Note 8: Between any two switches.

Note 9: Leakage testing at single supply is guaranteed by testing with dual supplies.

2.5Ω, Dual, SPST, CMOS Analog Switches

Typical Operating Characteristics

($T_A = +25^\circ\text{C}$, unless otherwise noted.)

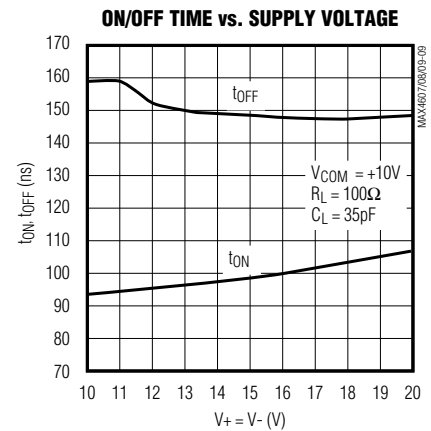
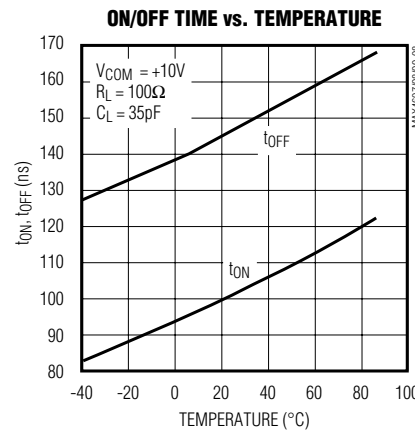
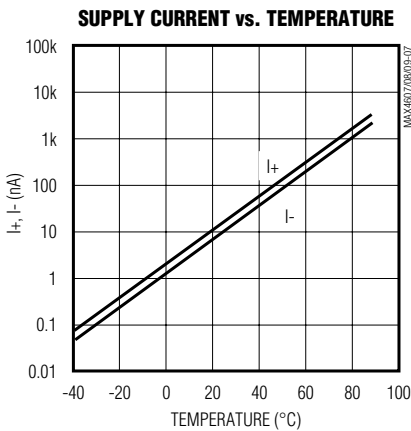
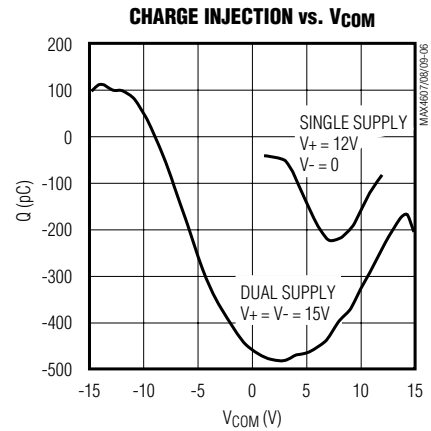
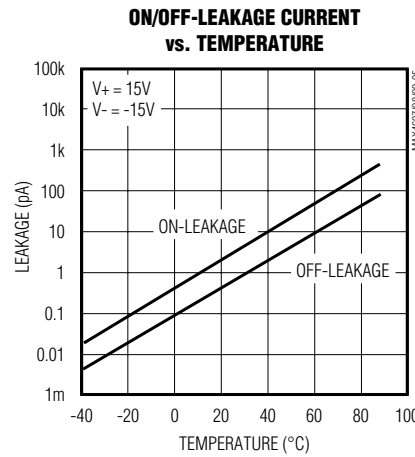
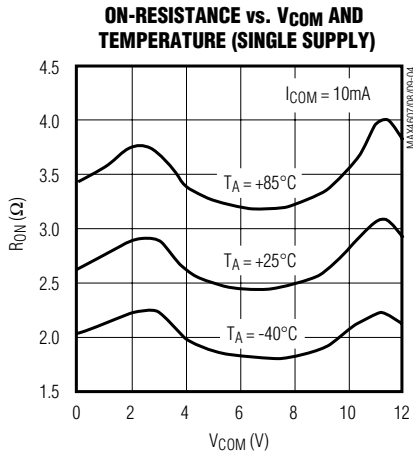
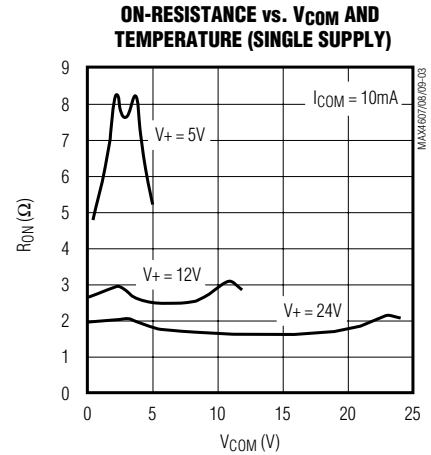
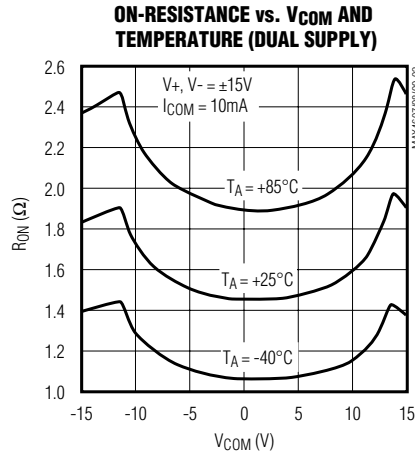
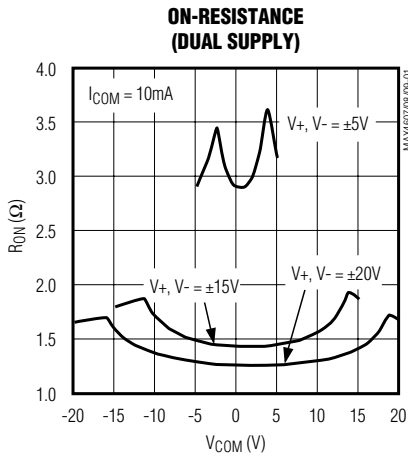

2.5Ω, Dual, SPST, CMOS Analog Switches

Typical Operating Characteristics (continued)

(T_A = +25°C, unless otherwise noted.)

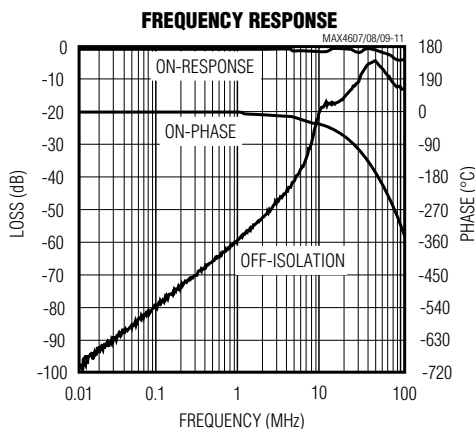
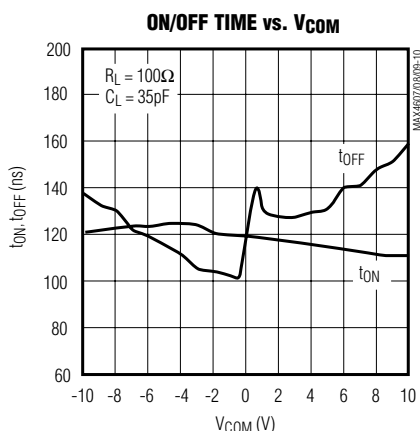

Pin Description

PIN			NAME	FUNCTION
MAX4607	MAX4608	MAX4609		
2, 7	2, 7	2, 7	IN2, IN2	Logic-Control Digital Inputs
14, 11	14, 11	14, 11	COM1, COM2	Analog Switch, Common Terminals
16, 9	—	—	NC1, NC2	Analog Switch, Normally Closed Terminals
—	16, 9	—	NO1, NO2	Analog Switch, Normally Open Terminals
—	—	9	NC1	Analog Switch, Normally Closed Terminal
—	—	16	NO1	Analog Switch, Normally Open Terminal
4	4	4	V-	Negative Analog Supply-Voltage Input. Connect to DGND for single-supply operation.
5	5	5	GND	Ground
1, 3, 6, 8, 10, 15	1, 3, 6, 8, 10, 15	1, 3, 6, 8, 10, 15	N.C.	No Connection. Not internally connected. Connect to GND as low impedance to improve on/off-isolation.
12	12	12	V _L	Logic-Supply Input
13	13	13	V+	Positive Analog-Supply Input

MAX4607/MAX4608/MAX4609

2.5Ω, Dual, SPST, CMOS Analog Switches

Applications Information

Overvoltage Protection

Proper power-supply sequencing is recommended for all CMOS devices. Do not exceed the absolute maximum ratings, because stresses beyond the listed ratings can cause permanent damage to the devices. Always sequence V+ on first, then V-, followed by the logic inputs, NO, or COM. If power-supply sequencing is not possible, add two small signal diodes (D1, D2) in series with supply pins for overvoltage protection (Figure 1). Adding diodes reduces the analog signal range to one diode drop below V+ and one diode drop above V-, but does not affect the devices' low switch resistance and low leakage characteristics. Device operation is unchanged, and the difference between V+ and V- should not exceed 44V. These protection diodes are not recommended when using a single supply.

Off-Isolation at High Frequencies

With the N.C. pins connected to GND, the high-frequency on-response of these parts extends from DC to above 100MHz with a typical loss of -2dB. When the switch is turned off, however, it behaves like a capacitor, and off-isolation decreases with increasing frequency. (Above 300MHz, the switch actually passes more signal turned off than turned on.) This effect is more pronounced with higher source and load impedances.

Above 5MHz, circuit-board layout becomes critical, and it becomes difficult to characterize the response of the switch independent of the circuit. The graphs shown in the *Typical Operating Characteristics* were taken using a 50Ω source and load connected with BNC connectors to a circuit board deemed "average;" that is, designed with isolation in mind, but not using strip-line or other special RF circuit techniques. For critical applications above 5MHz, use the MAX440, MAX441, and MAX442, which are fully characterized up to 160MHz.

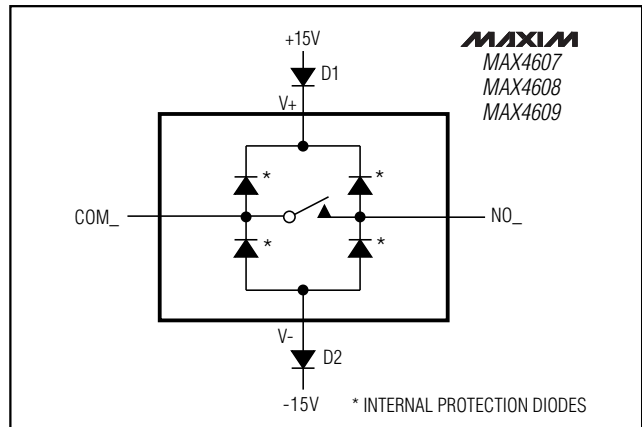

Figure 1. Overvoltage Protection Using External Blocking Diodes

Test Circuits/Timing Diagrams

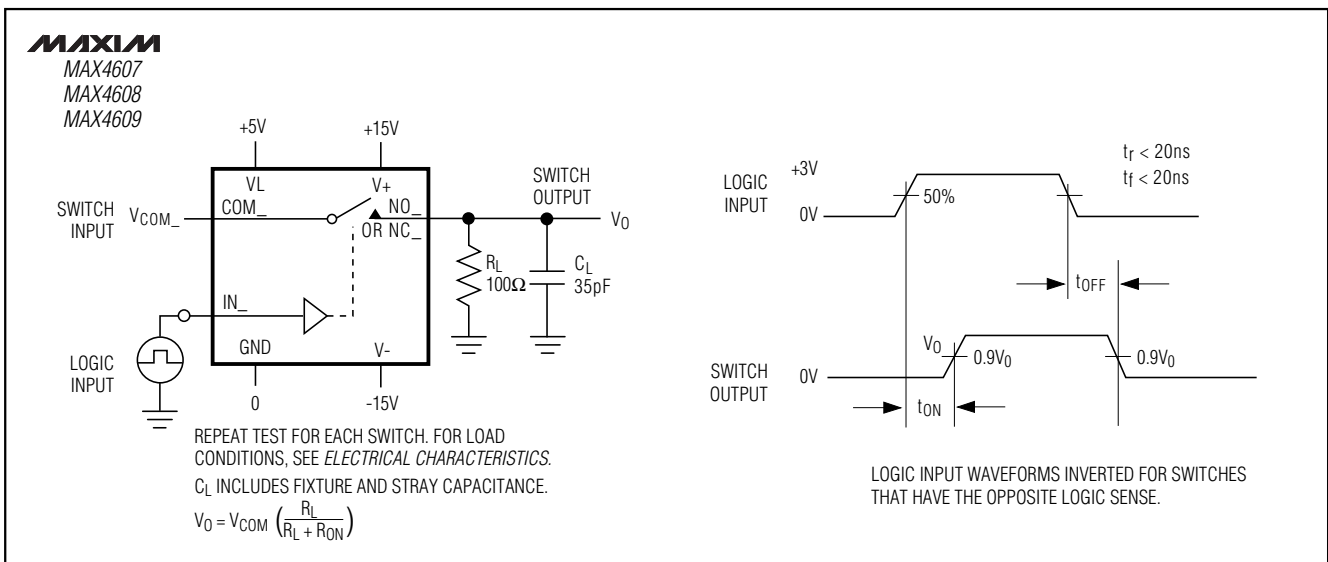

Figure 2. Switching-Time Test Circuit

2.5Ω, Dual, SPST, CMOS Analog Switches

Test Circuits/Timing Diagrams (continued)

MAX4607/MAX4608/MAX4609

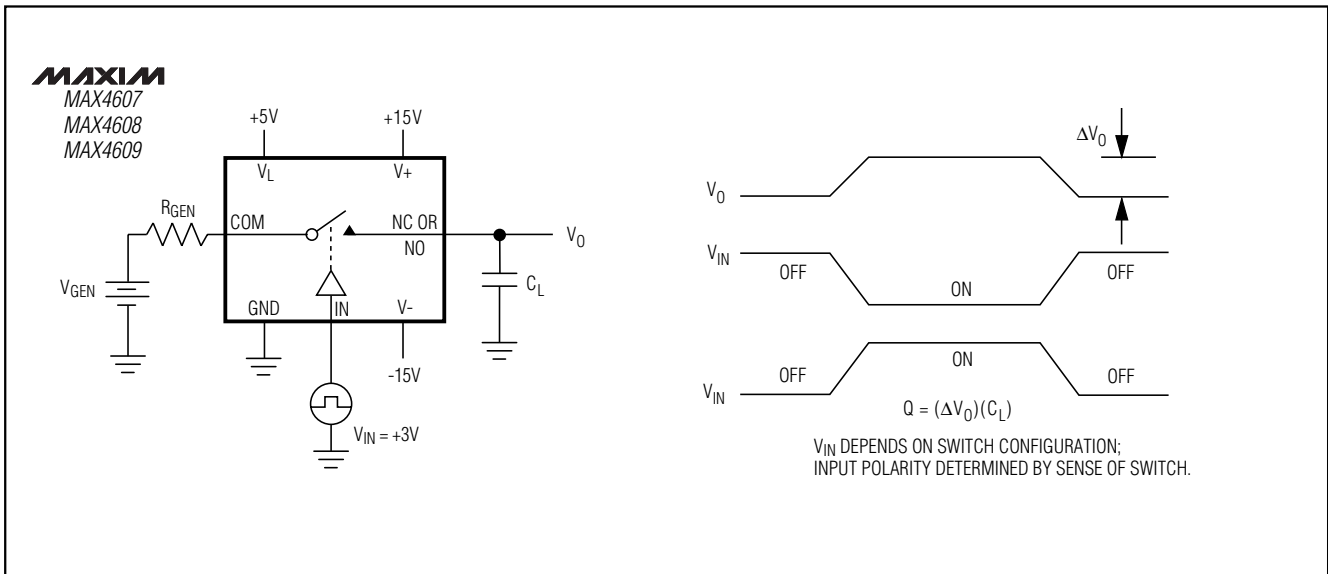

Figure 3. Charge-Injection Test Circuit

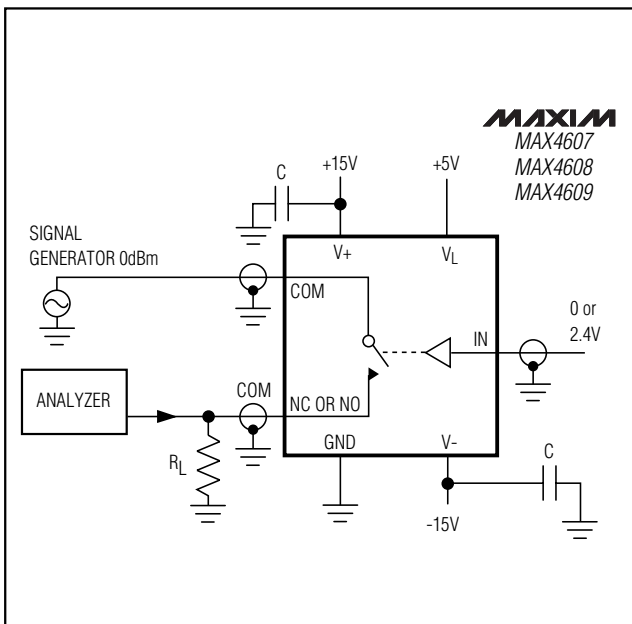

Figure 4. Off-Isolation Test Circuit

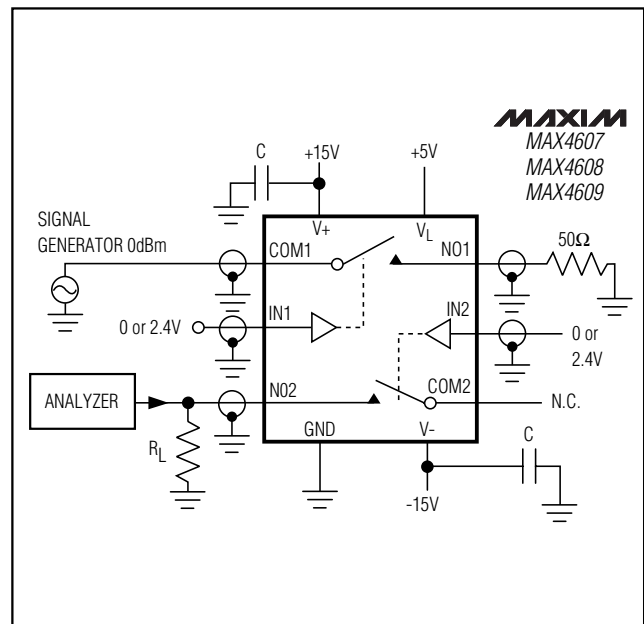

Figure 5. Crosstalk Test Circuit

2.5Ω, Dual, SPST, CMOS Analog Switches

Test Circuits/Timing Diagrams (continued)

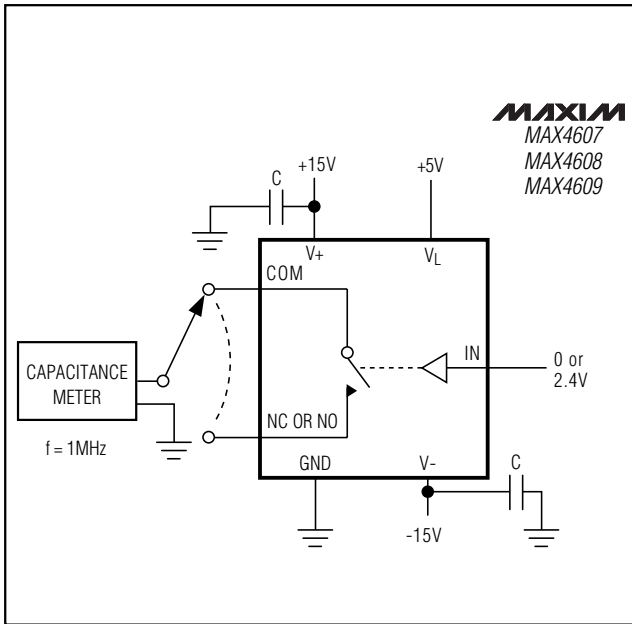

Figure 6. Switch Off-Capacitance Test Circuit

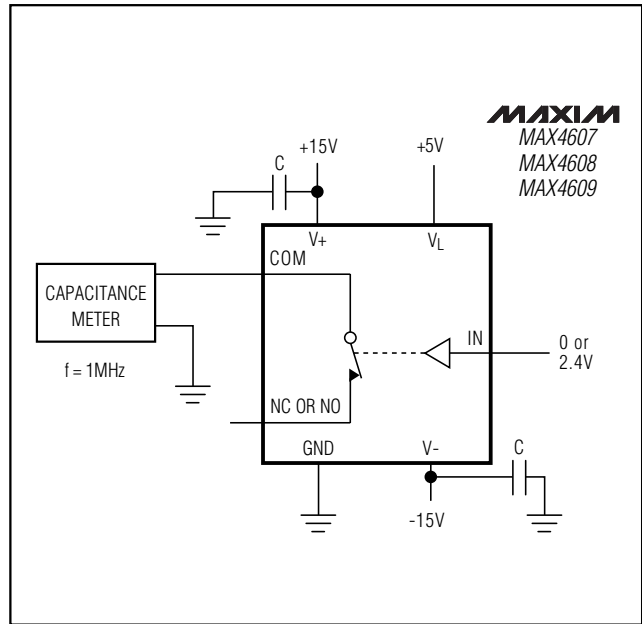

Figure 7. Switch On-Capacitance Test Circuit

Ordering Information (continued)

PART	TEMP. RANGE	PIN-PACKAGE
MAX4608 CSE	0°C to +70°C	16 Narrow SO
MAX4608CPE	0°C to +70°C	16 Plastic DIP
MAX4608ESE	-40°C to +85°C	16 Narrow SO
MAX4608EPE	-40°C to +85°C	16 Plastic DIP
MAX4609 CSE	0°C to +70°C	16 Narrow SO
MAX4609CPE	0°C to +70°C	16 Plastic DIP
MAX4609ESE	-40°C to +85°C	16 Narrow SO
MAX4609EPE	-40°C to +85°C	16 Plastic DIP

Chip Information

TRANSISTOR COUNT: 100

2.5Ω, Dual, SPST, CMOS Analog Switches

Package Information

MAX4607/MAX4608/MAX4609

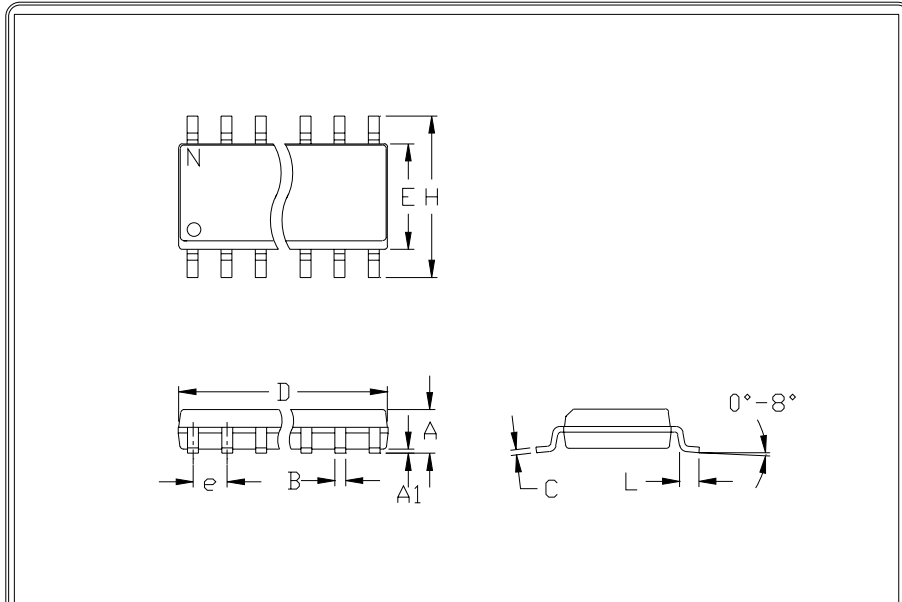

	INCHES		MILLIMETERS	
	MIN	MAX	MIN	MAX
A	0.053	0.069	1.35	1.75
A1	0.004	0.010	0.10	0.25
B	0.014	0.019	0.35	0.49
C	0.007	0.010	0.19	0.25
e	0.050		1.27	
E	0.150	0.157	3.80	4.00
H	0.228	0.244	5.80	6.20
h	0.010	0.020	0.25	0.50
L	0.016	0.050	0.40	1.27

	INCHES		MILLIMETERS		N	MS012
	MIN	MAX	MIN	MAX		
D	0.189	0.197	4.80	5.00	8	A
D	0.337	0.344	8.55	8.75	14	B
D	0.386	0.394	9.80	10.00	16	C

NOTES:

1. D&E DO NOT INCLUDE MOLD FLASH
2. MOLD FLASH OR PROTRUSIONS NOT TO EXCEED .15mm (.006")
3. LEADS TO BE COPLANAR WITHIN .102mm (.004")
4. CONTROLLING DIMENSION: MILLIMETER
5. MEETS JEDEC MS012-XX AS SHOWN IN ABOVE TABLE
6. N = NUMBER OF PINS



PACKAGE FAMILY OUTLINE: SOIC .150"

1/1

21-0041 A
DOCUMENT CONTROL NUMBER REV

2.5Ω, Dual, SPST, CMOS Analog Switches

Package Information (continued)

PDIP:EPS

	INCHES		MILLIMETERS	
	MIN	MAX	MIN	MAX
A	---	0.180	---	4.572
A1	0.020	---	0.508	---
A2	0.125	0.175	3.18	4.45
A3	0.055	0.080	1.40	2.03
B	0.015	0.021	0.381	0.533
B1	0.045	0.060	1.14	1.524
C	0.009	0.014	0.229	0.355
D1	0.005	0.080	0.13	2.03
E	0.300	0.325	7.62	8.255
E1	0.275	0.295	6.985	7.493
e	0.100	---	2.54	---
eA	0.300	---	7.62	---
eB	---	0.400	---	10.16
L	0.115	0.150	2.921	3.81

	INCHES		MILLIMETERS		N	MS001
	MIN	MAX	MIN	MAX		
D	0.348	0.390	8.84	9.91	8	AB
D	0.735	0.765	18.67	19.43	14	AC
D	0.745	0.765	18.92	19.43	16	AA
D	0.885	0.915	22.48	23.24	18	AD
D	1.015	1.045	25.78	26.54	20	AE
D	1.14	1.265	28.96	32.13	24	AF
D	1.360	1.380	34.54	35.05	28	*5

NOTES:
 1. D&E DO NOT INCLUDE MOLD FLASH
 2. MOLD FLASH OR PROTRUSIONS NOT TO EXCEED .15mm (.006")
 3. CONTROLLING DIMENSION: MILLIMETER
 4. MEETS JEDEC MS001-XX AS SHOWN IN ABOVE TABLE
 5. SIMILAR TO JEDEC MS-095-AH
 6. N = NUMBER OF PINS

20 000 0000 00 000000 00 0000 00 0000
 PROPRIETARY INFORMATION

PACKAGE FAMILY OUTLINE: PDIP .300"

21-0043 B
REVISION CONTROL NUMBER REV

Maxim cannot assume responsibility for use of any circuitry other than circuitry entirely embodied in a Maxim product. No circuit patent licenses are implied. Maxim reserves the right to change the circuitry and specifications without notice at any time.