



IGBT-Driving Hybrid ICs (EXB8.-Series) Application Manual

Content:

1. Introduction	page 1
2. Features	page 1
3. Applications	page 1
4. Comprehensive Chart	page 1
5. Dimensions	page 1
6. Functional Block Diagrams	page 2
7. Ratings and Characteristics	page 2
8. Application Circuits	page 3
9. Operation	page 6
10. Notes	page 7
11. Operating Waveforms	page 8
12. Additional Type EXB 844	page 10



1. Introduction

The insulated gate bipolar transistor (IGBT) is increasingly being used in small, low-noise, high-performance power supplies, inverters, uninterruptable power supplies (UPS), and motor speed controls.

Fuji's Hybrid IC driver for IGBTs was developed to take full advantage of the IGBT.

2. Features

- Various series
 - Standard series: For up to 10 kHz operation
 - High-speed series: For up to 40 kHz operation
 These series cover the full range of IGBT products.
- Built-in photocoupler for high isolation voltage: 2500 V AC for one minute
- Single supply operation
- Built-in overcurrent protection circuit
- Overcurrent detection output
- SIL package for high-density mounting

3. Applications

- General-purpose inverter and motor control
- Servo control
- Uninterruptable power supplies (UPS)
- Welding machines

4. Comprehensive Chart

IGBT	600 V IGBT drive		1200 V IGBT drive	
	Up to 150A	Up to 400A	Up to 75A	Up to 300A
Standard type	EXB850	EXB851	EXB850	EXB851
High-speed type	EXB840	EXB841	EXB840	EXB841

Notes: 1. Standard type: Signal delay in drive circuit; Up to 4μs (max.)
 2. High-speed type: Signal delay in drive circuit; Up to 1.5μs (max.)

5. Dimensions, mm

- EXB850
- EXB840
- EXB851
- EXB841

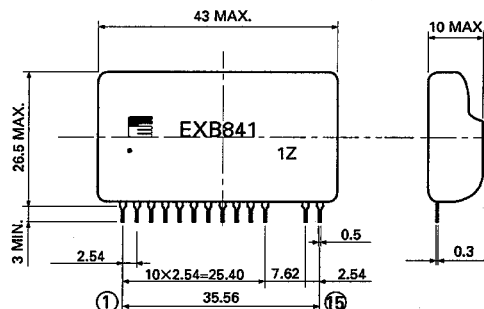
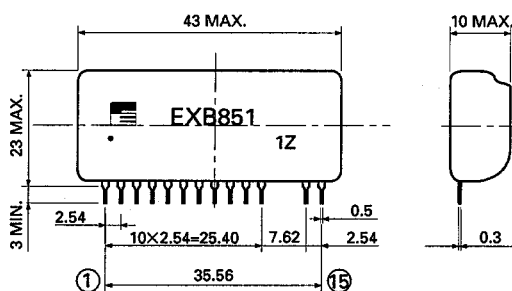

IGBT-Driving Hybrid ICs (EXB8..-Series) Application Manual

6. Functional Block Diagrams

EXB850, 851

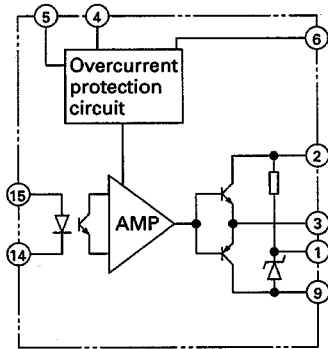

EXB840, 841

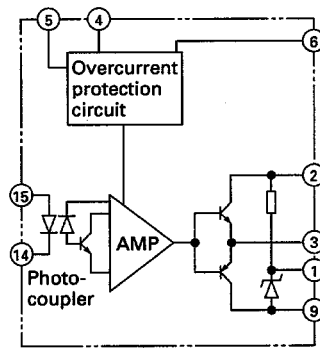

Notation common to all EXB series

Pin number	Description
①	Connected to smoothing capacitor for reverse bias power supply
②	Power supply (+20 V)
③	Drive output
④	For connecting an external capacitor to protect against malfunction of the overcurrent protection circuit. (The capacitor is not needed in most cases.)
⑤	Overcurrent detection output
⑥	Collector voltage monitoring
⑦ ⑧	Not connected
⑨	Power supply (0 V)
⑩ ⑪	Not connected
⑭	Drive signal input (-)
⑮	Drive signal input (+)

7. Ratings and Characteristics

■ Absolute maximum ratings

(Ta = 25°C)

Item	Symbol	Condition	Rating		Unit
			EXB850, EXB840 (Medium capacity)	EXB851, EXB841 (Large capacity)	
Supply voltage	V cc		25		V
Photocoupler input current	I in		25		mA
Forward bias output current	I g1	PW = 2 μs, duty at 0.05 or less	1.5	4.0	A
Reverse bias output current	I g2	PW = 2 μs, duty at 0.05 or less	1.5	4.0	A
Input/Output isolation voltage	V ISO	AC 50/60 Hz, 1 minute	2500		V
Operating surface temperature	T c		-25 to +85		°C
Storage temperature	T stg		-25 to +125		°C

■ Recommended operating conditions

Item	Symbol	Recommended operating conditions				Unit
		Standard type		High-speed type		
		EXB850	EXB851	EXB840	EXB841	
Supply voltage	V cc	20 ⁺² ₋₀				V
Photocoupler input current	I in	5		10		mA

IGBT-Driving Hybrid ICs (EXB8..Series) Application Manual

■ Electrical characteristics

(Ta = 25°C)

Item	Symbol	Condition	Rating						Unit
			EXB840, EXB841 (High speed)			EXB850, EXB851 (Medium speed)			
			Min.	Typ.	Max.	Min.	Typ.	Max.	
Turn-on time 1	t on	V _{cc} = 20 V, I _F = 5 mA			1.5			2.0	μsec
Turn-on time 2	t off	V _{cc} = 20 V, I _F = 5 mA			1.5			4.0	μsec
Overcurrent protection voltage	V _{ocp}	V _{cc} = 20 V, I _F = 5 mA		8.5			8.5		V
Overcurrent protection delay	t _{ocp}	V _{cc} = 20 V, I _F = 5 mA			10			10	μsec
Alarm delay	t _{ALM}	V _{cc} = 20 V, I _F = 5 mA			1			1	μsec
Reverse bias power supply voltage	V _{RB}	V _{cc} = 20 V		5			5		V

Note: EXB851 and EXB850 (medium speed) require I_F overdrive shown in the application circuit.

8. Application Circuits

1 EXB850 Application Circuits

EXB850 is a hybrid IC capable of driving up to 150A for a 600V IGBT and up to 75A for a 1200 V IGBT. Since the signal delay in the drive circuit is 4μs or less, the hybrid IC is suitable for switching at up to about 10 kHz.

Note the following when using the hybrid IC:

- The IGBT gate-emitter drive loop wiring must be shorter than one meter.
- The IGBT gate-emitter drive wiring should be twisted.
- If a large voltage spike is generated at the collector of the IGBT, increase the IGBT's gate series resistor (RG).
- The 33 μF (#) capacitor absorbs changes in the supply voltage caused by the power supply wiring impedance. It is not a power supply filter capacitor.

Control circuit PC board

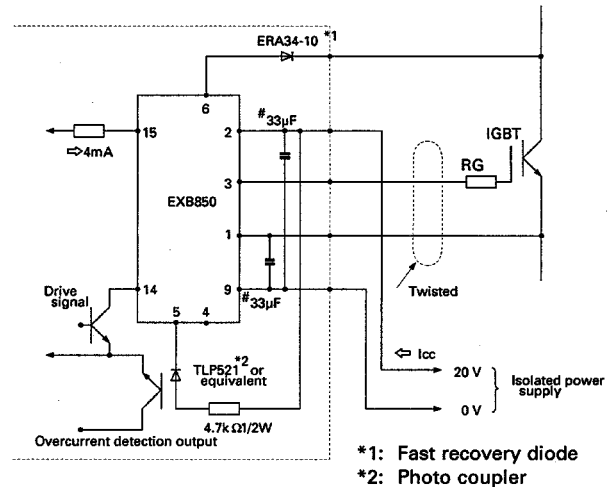

Recommended gate resistance and current consumption

IGBT rating	600 V	10 A	15 A	30 A	50 A	75 A	100 A	150 A	
	1200 V	—	—	8 A	15 A	25 A	—	50 A	75 A
RG	250 Ω		150 Ω	82 Ω	50 Ω	33 Ω	25 Ω	15 Ω	
I _{cc}	5 kHz	24 mA				24 mA			26 mA
	10 kHz		25 mA			29 mA			
	15 kHz		25 mA			32 mA			

IGBT-Driving Hybrid ICs (EXB8..-Series) Application Manual

2 EXB851 Application Circuits

EXB851 is a hybrid IC capable of driving up to 400A for 600 V IGBT and up to 300A for a 1200 V IGBT. Since the signal delay in the drive circuit is 4 μ s or less, the hybrid IC is suitable for switching at up to about 10 kHz.

Note the following when using the hybrid IC:

- The IGBT's gate-emitter drive loop wiring must be shorter than one meter.
- The IGBT's gate-emitter drive wiring should be twisted.
- If a large voltage spike is generated at the collector of the IGBT, increase the IGBT's gate series resistor(RG).
- The 47 μ F (#) capacitor absorbs changes in the supply voltage caused by the power supply wiring impedance. It is not a power supply filter capacitor.

Recommended gate resistance and current consumption

IGBT rating	600 V	200 A	300 A	400 A	—
	1200 V	200 A	150 A	200 A	300 A
RG		12 Ω	8.2 Ω	5 Ω	3.3 Ω
I _{cc}	5 kHz	27 mA	29 mA	30 mA	34 mA
	10 kHz	31 mA	34 mA	37 mA	44 mA
	15 kHz	34 mA	39 mA <td 44 mA	54 mA	

3 EXB840 Application Circuits

EXB840 is a hybrid IC capable of driving up to 150A for 600 V IGBT and up to 75A for a 1200 V IGBT. Since the signal delay in the drive circuit is 1 μ s or less, the hybrid IC is suitable for switching at up to about 40 kHz.

Note the following when using the hybrid IC:

- The IGBT's gate-emitter drive loop wiring must be shorter than one meter.
- The IGBT's gate-emitter drive wiring should be twisted.
- If a large voltage spike is generated at the collector of the IGBT, increase the IGBT's gate series resistor(RG).
- The 33 μ F (#) capacitor absorbs changes in the supply voltage caused by the power supply wiring impedance. It is not a power supply filter capacitor.

Control circuit PC board

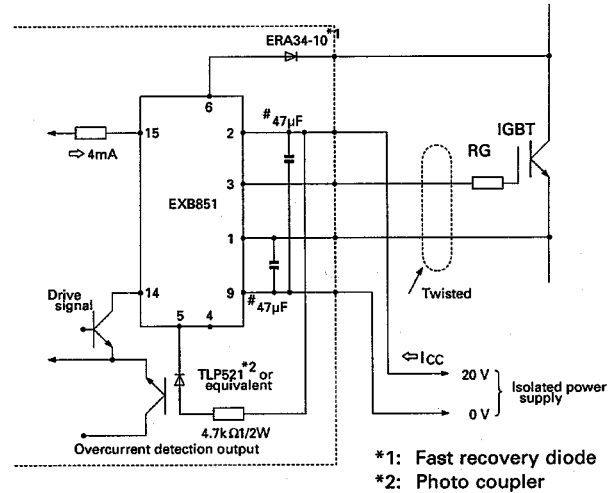

Control circuit PC board

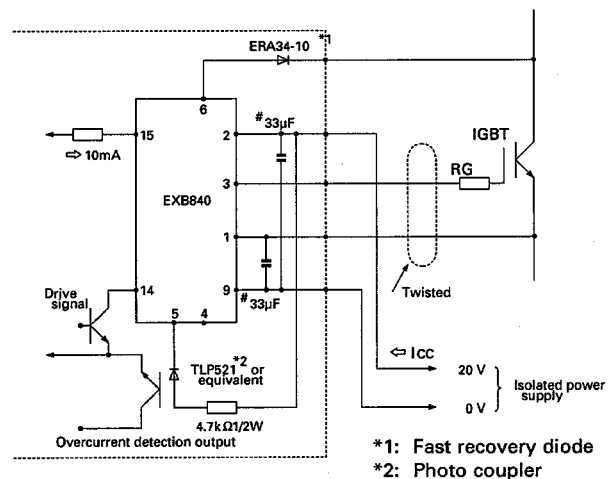

IGBT-Driving Hybrid ICs (EXB8..-Series) Application Manual

Recommended gate resistance and current consumption

IGBT rating	600 V	10 A	15 A	30 A	50 A	75 A	100 A	150 A
	1200 V	—	8 A	15 A	25 A	—	50 A	75 A
RG	250 Ω		150 Ω	82 Ω	50 Ω	33 Ω	25 Ω	15 Ω
I _{cc}	5 kHz	17 mA			17 mA			19 mA
	10 kHz	17 mA			18 mA			22 mA
	15 kHz	18 mA			20 mA			25 mA

4 EXB841 Application Circuits

EXB841 is a hybrid IC capable of driving up to 400A for 600 V IGBT and up to 300A for a 1200 V IGBT. Since the signal delay in the drive circuit is 1μs or less, the hybrid IC is suitable for switching at up to about 40 kHz.

Note the following when using the hybrid IC:

- The IGBT's gate-emitter drive loop wiring must be shorter than one meter.
- The IGBT's gate-emitter drive wiring should be twisted.
- If a large voltage spike is generated at the collector of the IGBT, increase the IGBT's gate series resistor(RG).
- The 47 μF (#) capacitor absorbs changes in the supply voltage caused by the power supply wiring impedance. It is not a power supply filter capacitor.

Control circuit PC board

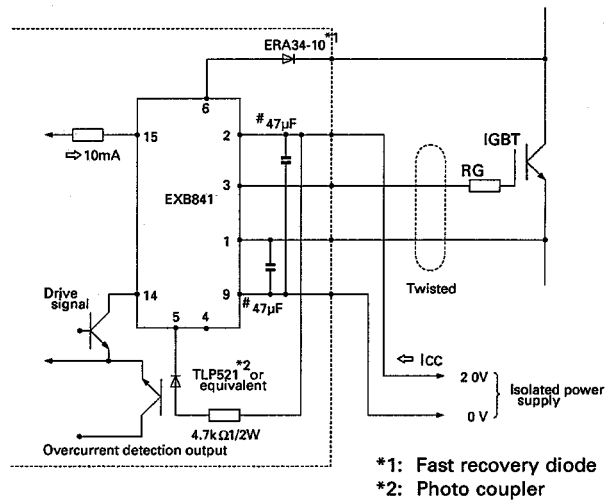

Recommended gate resistance and current consumption

IGBT rating	600 V	200 A	300 A	400 A	—
	1200 V	200 A	150 A	200 A	300 A
RG	12 Ω		8.2 Ω	5 Ω	3.3 Ω
I _{cc}	5 kHz	20 mA	22 mA	23 mA	27 mA
	10 kHz	24 mA	27 mA	30 mA	37 mA
	15 kHz	27 mA	32 mA	37 mA	47 mA

9. Operation

1 Outline

The following built-in functions make the fullest use of the IGBT.

- Signal isolation circuit
- Drive amplifier
- Overcurrent detector
- Low speed overcurrent cut-off circuit
- Gate turn-off power supply

2 Signal isolation circuit

A photocoupler with a high isolation voltage is used for signal isolation. Therefore, this hybrid IC can be used in devices powered from 480 V AC.

High-speed or general-purpose photocouplers are selected according to the specifications of the hybrid IC because the drive circuit signal delay depends on the photocoupler characteristics.

3 Overcurrent detector

The IGBT can withstand an overcurrent of only 10 μ s duration when short-circuited. An extremely fast protection circuit is necessary for this reason.

This hybrid IC incorporates an overcurrent protection circuit. An overcurrent is detected according to the relationship between the drive signal and the collector voltage.

The principle of overcurrent detection is shown at the right. An overcurrent is considered present when the collector voltage is high although an on signal is inputted.

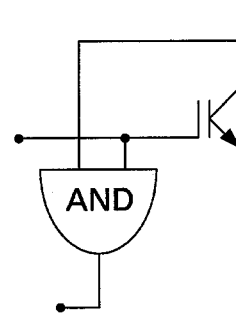
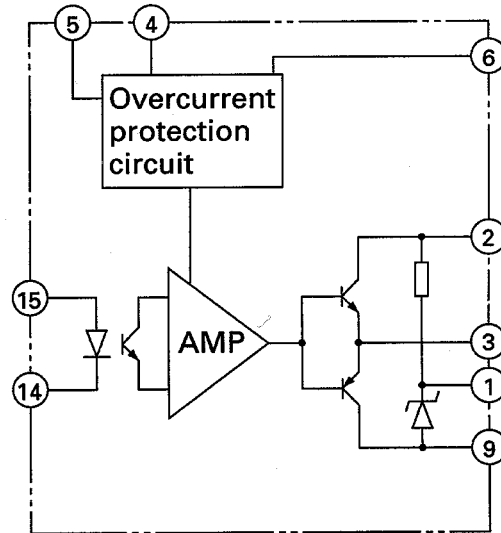

	VCE low	VCE high
On signal	Normal	Overcurrent
Off signal	—	Normal

4 Low-speed overcurrent cut-off circuit

A low-speed cut-off circuit slowly turns off the IGBT in response to an overcurrent.

When an overcurrent is cut off at normal drive speed, the collector voltage spike generated is large enough to damage the IGBT.

The low-speed cut-off circuit protects the IGBT against damage.

(The low-speed cut-off circuit does not operate for overcurrents of 10 μ s or less duration.)

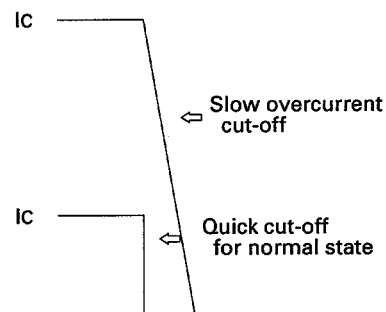

5 Gate turn-off power supply

The IGBT needs a +15 V on-gate voltage to get a low on-voltage and -5 V off-gate voltage to protect against malfunction in the off state.

This is a built-in circuit which generates a constant-voltage supply from the 20 V supply for IGBT gate turn-off.

Do not apply external voltage to pin 1.

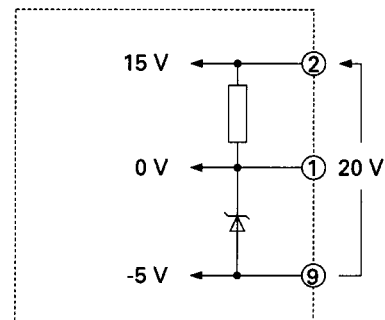

10. Notes

1 Separation of input circuit from output circuit
Keep the wiring of the input circuit (photocoupler) away from the output circuit wiring to assure that the proper dielectric strength and high noise resistance are maintained.

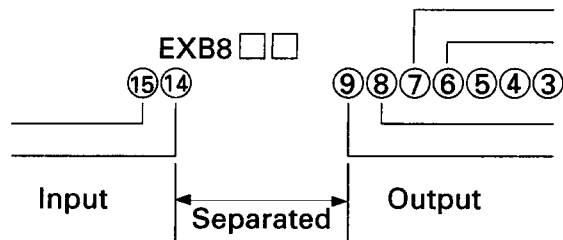

2 Use under recommended operating conditions

The IGBT works best if the recommended operating conditions driven in Section 7 are observed.

- Note that an excessive drive supply voltage could damage the IGBT due to excess IGBT gate voltage, and that an insufficient drive voltage could abnormally increase the IGBT's ON voltage.
- Note that an excessive input current could increase the signal delay in the drive circuit, and that an insufficient input current could cause unstable operation of the drive circuit.
- Note that an insufficient gate resistance can increase the switching noise of the IGBT and freewheeling diode.
- Note the points above where the recommended operating conditions cannot be observed.

11. Operating Waveforms

1 EXB850

Operating conditions

$V_{cc} = 20\text{ V}$, $I_{in} = 4\text{ mA}$, IGBT module: 2MB150-060

Test circuits

Input-output waveforms

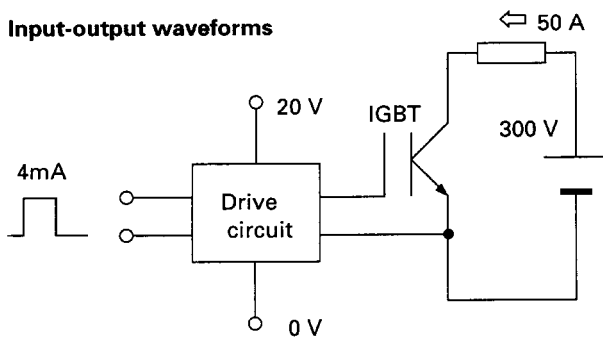

Waveforms at overcurrent

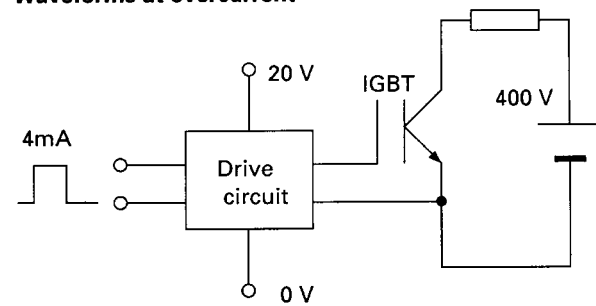

Input-Output waveforms

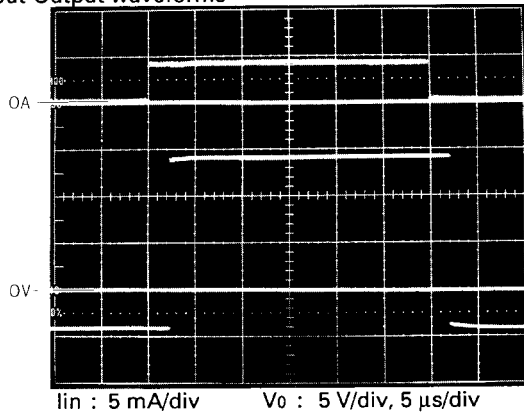

Waveforms at overcurrent

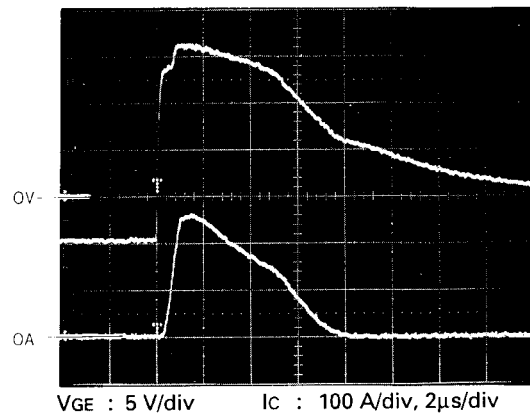
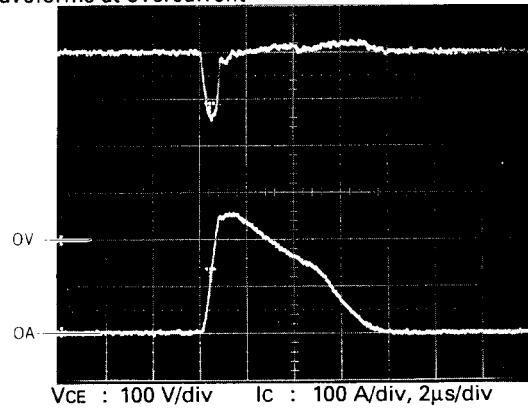

IGBT-Driving Hybrid ICs (EXB8..-Series) Application Manual

2 EXB841

Operating conditions

$V_{cc} = 20\text{ V}$, $I_{in} = 10\text{ mA}$, IGBT module: 2MB150-060

Test circuit

Input-output waveforms

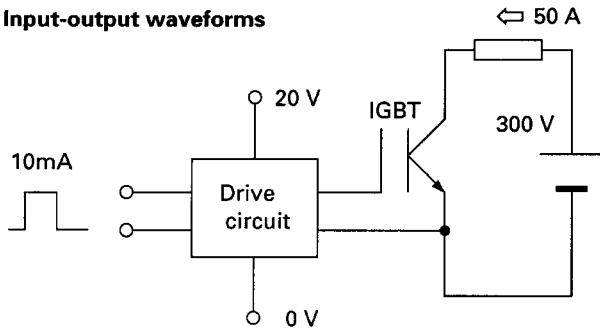

Waveforms at overcurrent

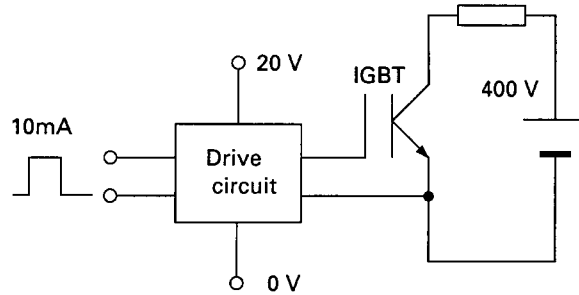

Input-Output waveforms

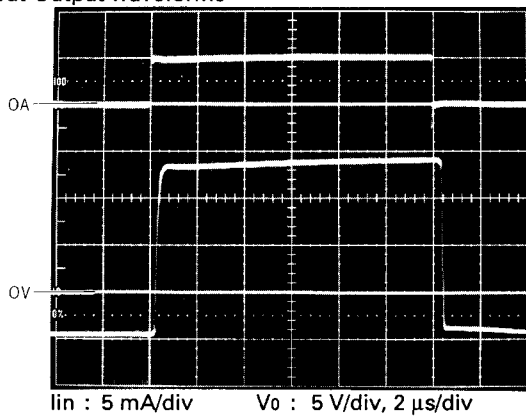

Waveforms at overcurrent are the same as for EXB851.

New Gate Driver Hybrid IC for 3rd Generation IGBT

1. Features

- (1) dv/dt capability of opto-coupler is Min.15KV/ μ s
- (2) Spacing between primary pin and secondary pin is 10.16mm
- (3) Isolation voltage is 2500Vrms/1 min.

2. Difference from existing type

	EXB841	New Driver
dv/dt	5 KV/ μ s	15 KV/ μ s
Delay time	1.5 μ s	1.5 μ s
Opto-coupler	TLP550 (TOSHIBA)	HPCL4504
Pin Arrangement		

For more information, contact:

Collmer Semiconductor, Inc.

P.O. Box 702708

Dallas, TX 75370

972-733-1700

972-381-9991 Fax

<http://www.collmer.com>