



Low-Voltage, Single-Supply, 10Ω SPST CMOS Analog Switches

General Description

The MAX4594–MAX4597 single-pole/single-throw (SPST) analog switches operate from a single +2.0V to +5.5V supply. The MAX4594/MAX4596 switches are normally open (NO), and the MAX4595/MAX4597 are normally closed (NC). The MAX4596/MAX4597 pinouts are optimized for the highest SC70 package off-isolation available.

These switches have 10Ω max on-resistance (R_{ON}), with 1.5Ω max R_{ON} flatness over the analog signal range when powered from a +5V supply. The MAX4594–MAX4597 offer low 0.5nA leakage currents and fast switching times less than 40ns. They are packaged in an ultra-small 5-pin SC70.

Applications

- Cellular Phones
- Battery-Operated Equipment
- Audio and Video Signal Routing
- Communications Circuits
- PCMCIA Cards
- DSL Modems

Features

- ◆ Available in SC70-5 Package
- ◆ 10Ω max On-Resistance
- ◆ 1.5Ω max On-Resistance Flatness
- ◆ Fast Switching
 $t_{ON} = 35ns$ max
 $t_{OFF} = 40ns$ max
- ◆ Guaranteed 5pC max Charge Injection
- ◆ +2.0V to +5.5V Single-Supply Operation
- ◆ 300MHz -3dB Bandwidth at +25°C
- ◆ TTL/CMOS-Logic Compatible
- ◆ -80dB Off-Isolation at 1MHz
- ◆ 0.5nA max Off-Leakage
- ◆ 0.05% THD

Ordering Information

PART	TEMP. RANGE	PIN-PACKAGE	TOP MARK
MAX4594EXK-T	-40°C to +85°C	5 SC70-5	AAH
MAX4595EXK-T	-40°C to +85°C	5 SC70-5	AAI
MAX4596EXK-T	-40°C to +85°C	5 SC70-5	AAJ
MAX4597EXK-T	-40°C to +85°C	5 SC70-5	AAK

Pin Configurations/Functional Diagrams/Truth Table

TOP VIEW

INPUT	SWITCH STATE	
	MAX4594/MAX4596	MAX4595/MAX4597
LOW	OFF	ON
HIGH	ON	OFF

SWITCHES SHOWN FOR LOGIC "0" INPUT.

MAX4594–MAX4597



Low-Voltage, Single-Supply, 10Ω SPST CMOS Analog Switches

ABSOLUTE MAXIMUM RATINGS

(Voltages Referenced to GND)

V+-0.3V to +6V
Voltage into Any Terminal (Note 1).....	-0.3V to (V+ + 0.3V)
Continuous Current into Any Terminal.....	±20mA
Peak Current, NO, NC, or COM (pulsed at 1ms, 10% duty cycle).....	±40mA

Continuous Power Dissipation (T_A = +70°C)

5-Pin SC70 (derate 3.1mW/°C above +70°C).....	247mW
Operating Temperature Range MAX459_EXK	-40°C to +85°C
Storage Temperature Range	-65°C to +150°C
Lead Temperature (soldering, 10s)	+300°C

Note 1: Voltages exceeding V+ or GND on any signal terminal are clamped by internal diodes. Limit forward-diode current to maximum current rating.

Stresses beyond those listed under "Absolute Maximum Ratings" may cause permanent damage to the device. These are stress ratings only, and functional operation of the device at these or any other conditions beyond those indicated in the operational sections of the specifications is not implied. Exposure to absolute maximum rating conditions for extended periods may affect device reliability.

ELECTRICAL CHARACTERISTICS—+5V Supply

(V+ = +4.5V to +5.5V, V_{IH} = +2.4V, V_{IL} = +0.8V, T_A = T_{MIN} to T_{MAX}, unless otherwise noted. Typical values are at V+ = +5V, T_A = +25°C.) (Notes 2, 3)

PARAMETER	SYMBOL	CONDITIONS	MIN	TYP	MAX	UNITS	
ANALOG SWITCH							
Analog Signal Range	V _{COM} , V _{NO} , V _{NC}		0		V+	V	
On-Resistance	R _{ON}	V+ = 4.5V, V _{NO} , or V _{NC} = 3.5V; I _{COM} = 10mA	T _A = +25°C	6.5	10	Ω	
			T _A = T _{MIN} to T _{MAX}				12
On-Resistance Flatness (Note 4)	R _{FLAT(ON)}	V _{NO} or V _{NC} = 1.5V, 2.5V, 3.5V; V+ = 4.5V; I _{COM} = 10mA	T _A = +25°C	0.5	1.5	Ω	
			T _A = T _{MIN} to T _{MAX}				2
NO or NC Off-Leakage Current	I _{NO(OFF)} I _{NC(OFF)}	V+ = 5.5V; V _{COM} = 1V, 4.5V; V _{NO} or V _{NC} = 4.5V, 1V	T _A = +25°C	-0.5	0.01	0.5	nA
			T _A = T _{MIN} to T _{MAX}	-5		5	
COM Off-Leakage Current	I _{COM(OFF)}	V+ = 5.5V; V _{COM} = 1V, 4.5V; V _{NO} or V _{NC} = 4.5V, 1V	T _A = +25°C	-0.5	0.01	0.5	nA
			T _A = T _{MIN} to T _{MAX}	-5		5	
COM On-Leakage Current	I _{COM(ON)}	V+ = 5.5V; V _{COM} = 1V; 4.5V; V _{NO} or V _{NC} = 1V, 4.5V, or floating	T _A = +25°C	-1	0.01	1	nA
			T _A = T _{MIN} to T _{MAX}	-10		10	
DIGITAL I/O							
Input Logic High	V _{IH}		2.4			V	
Input Logic Low	V _{IL}				0.8	V	
Input Logic Current	I _{IH} , I _{IL}	V _{IN} = V+, 0	-1	0.03	1	μA	
DYNAMIC							
Turn-On Time	t _{ON}	V _{NO} or V _{NC} = 3V, R _L = 300Ω, C _L = 35pF, Figure 3	T _A = +25°C	20	35	ns	
			T _A = T _{MIN} to T _{MAX}				45
Turn-Off Time	t _{OFF}	V _{NO} or V _{NC} = 3V, R _L = 300Ω, C _L = 35pF, Figure 3	T _A = +25°C	25	40	ns	
			T _A = T _{MIN} to T _{MAX}				50
On-Channel -3dB Bandwidth	BW	Signal = 0dBm, 50Ω in and out, Figure 4	T _A = +25°C	300		MHz	

Low-Voltage, Single-Supply, 10Ω SPST CMOS Analog Switches

MAX4594-MAX4597

ELECTRICAL CHARACTERISTICS—+5V Supply (continued)

(V₊ = +4.5V to +5.5V, V_{IH} = +2.4V, V_{IL} = +0.8V, T_A = T_{MIN} to T_{MAX}, unless otherwise noted. Typical values are at V₊ = +5V, T_A = +25°C.) (Notes 2, 3)

PARAMETER	SYMBOL	CONDITIONS		MIN	TYP	MAX	UNITS
Charge Injection (Note 5)	Q	V _{NO} or V _{NC} = 0, C _L = 1nF, Figure 2	T _A = +25°C		2	5	pC
Off-Isolation (Note 6)	V _{ISO}	V _{NO} or V _{NC} = 1V _{RMS} , R _L = 50Ω, C _L = 5pF, f = 1MHz, Figure 4	T _A = +25°C		80		dB
					83		
NO or NC Off-Capacitance	C _{NO(OFF)} , C _{NC(OFF)}	V _{NO} or V _{NC} = 0, f = 1MHz, Figure 5	T _A = +25°C		8		pF
COM Off-Capacitance	C _{COM(OFF)}	V _{COM} = 0, f = 1MHz, Figure 5	T _A = +25°C		8		pF
COM On-Capacitance	C _{COM(ON)}	V _{COM} = 0, f = 1MHz, Figure 5	T _A = +25°C		20		pF
Total Harmonic Distortion Plus Noise	THD	V = 5Vp-p, R _L = 600Ω, f = 20Hz to 20kHz	T _A = +25°C		0.05		%
POWER SUPPLY							
Power-Supply Range	V ₊			2.0		5.5	V
V ₊ Supply Current	I ₊	V ₊ = 5.5V, V _{IN} = 0 or V ₊	T _A = T _{MIN} to T _{MAX}	-1		1	μA

ELECTRICAL CHARACTERISTICS—+3V Supply

(V₊ = +2.7V to +3.6V, V_{IH} = +2.0V, V_{IL} = +0.8V, T_A = T_{MIN} to T_{MAX}, unless otherwise noted. Typical values are at V₊ = +3.0V, T_A = +25°C.) (Notes 2, 3)

PARAMETER	SYMBOL	CONDITIONS		MIN	TYP	MAX	UNITS
ANALOG SWITCH							
Analog Signal Range	V _{COM} , V _{NO} , V _{NC}			0		V ₊	V
On-Resistance	R _{ON}	V _{NO} or V _{NC} = 1.5V, I _{COM} = 10mA, V ₊ = 2.7V	T _A = +25°C		10	20	Ω
			T _A = T _{MIN} to T _{MAX}			25	
DIGITAL I/O							
Input Logic High	V _{IH}			2.0			V
Input Logic Low	V _{IL}					0.8	V
Input Logic Current	I _{IH} , I _{IL}	V _{IN} = V ₊ , 0		-1	0.03	1	μA
DYNAMIC							
Turn-On Time	t _{ON}	V _{NO} or V _{NC} = 2V, R _L = 300Ω, C _L = 35pF, Figure 3	T _A = +25°C		25	45	ns
			T _A = T _{MIN} to T _{MAX}			55	
Turn-Off Time	t _{OFF}	V _{NO} or V _{NC} = 2V, R _L = 300Ω, C _L = 35pF, Figure 3	T _A = +25°C		30	50	ns
			T _A = T _{MIN} to T _{MAX}			60	
Charge Injection (Note 5)	Q	V _{NO} or V _{NC} = 0, C _L = 1nF, Figure 2	T _A = +25°C		2	4	pC

Low-Voltage, Single-Supply, 10Ω SPST CMOS Analog Switches

ELECTRICAL CHARACTERISTICS—+3V Supply (continued)

($V_+ = +2.7V$ to $+3.6V$, $V_{IH} = +2.0V$, $V_{IL} = +0.8V$, $T_A = T_{MIN}$ to T_{MAX} , unless otherwise noted. Typical values are at $V_+ = +3.0V$, $T_A = +25^\circ C$.) (Notes 2, 3)

PARAMETER	SYMBOL	CONDITIONS	MIN	TYP	MAX	UNITS
POWER SUPPLY						
V+ Supply Current	I+	$V_+ = 3.6V$, $V_{IN} = 0$ or V_+	$T_A = T_{MIN}$ to T_{MAX}	-1	1	μA

Note 2: Parameters are 100% tested at $+25^\circ C$ only, and guaranteed by correlation at the full-rated temperature.

Note 3: Algebraic convention is used in this data sheet; the most negative value is shown in the minimum column.

Note 4: Flatness is defined as the difference between the maximum and minimum values of on-resistance as measured over the specified analog signal ranges.

Note 5: Guaranteed by design.

Note 6: Off-Isolation = $20\log_{10}(V_{COM} / V_{NO})$, V_{COM} = output, V_{NO} = input to off switch.

Typical Operating Characteristics

($V_+ = +5V$, $T_A = +25^\circ C$, unless otherwise noted.)

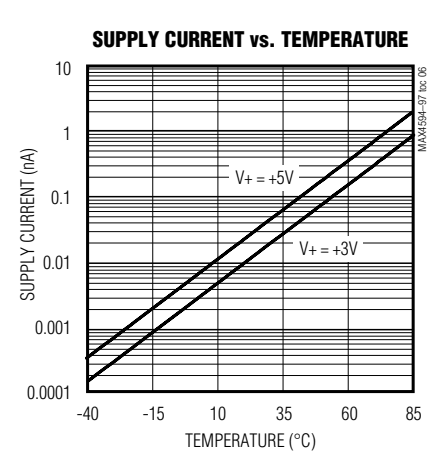
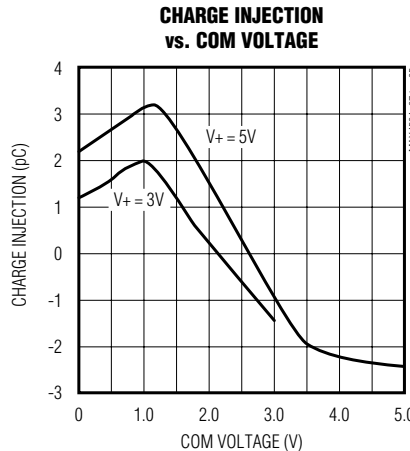
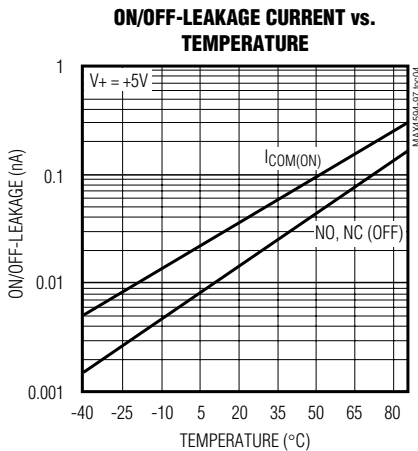
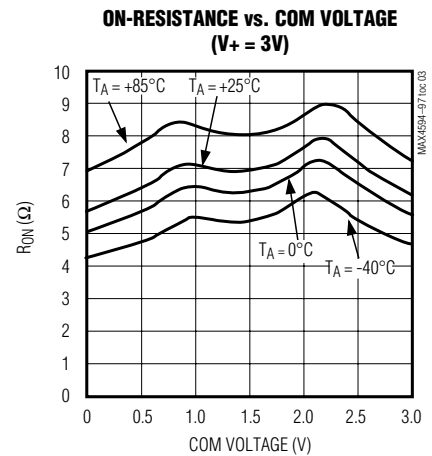
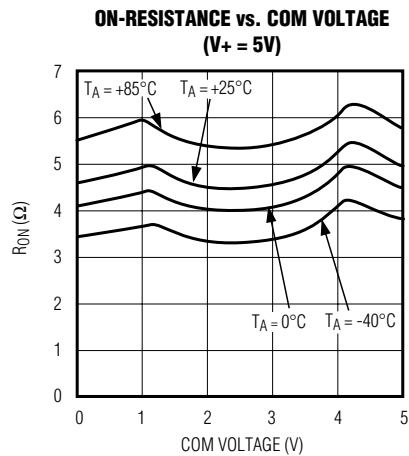
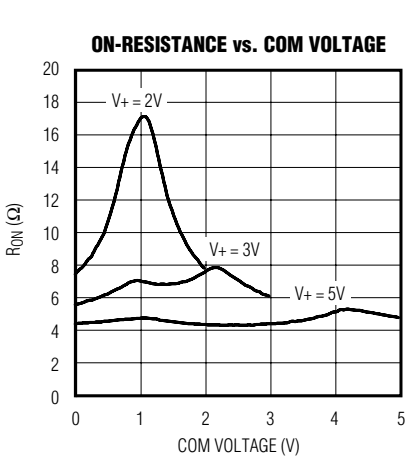

Low-Voltage, Single-Supply, 10Ω SPST CMOS Analog Switches

MAX4594-MAX4597

Typical Operating Characteristics (continued)

(V+ = +5V, TA = +25°C, unless otherwise noted.)

LOGIC THRESHOLD vs. SUPPLY VOLTAGE

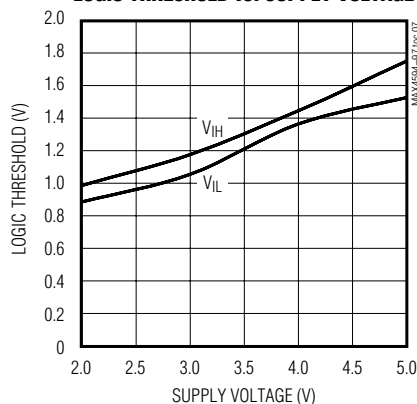

TURN-ON/TURN-OFF TIME vs. SUPPLY VOLTAGE

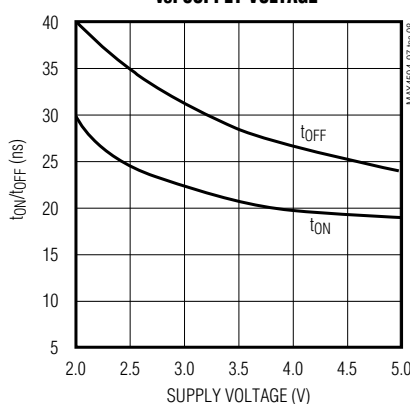

TURN-ON/TURN-OFF TIME vs. TEMPERATURE

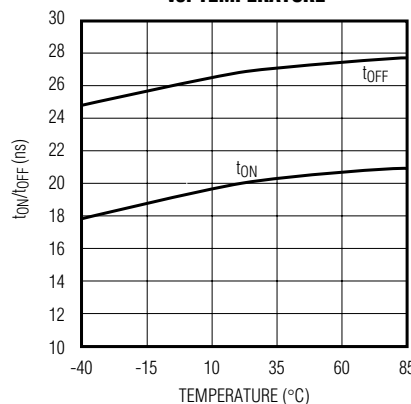

FREQUENCY RESPONSE

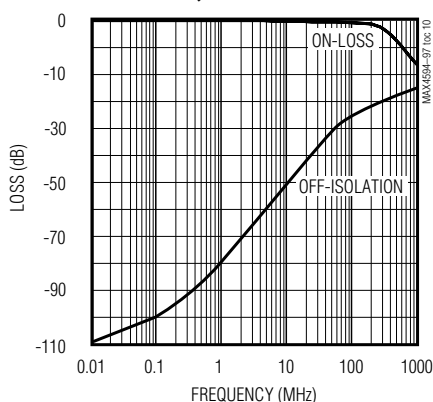

TOTAL HARMONIC DISTORTION PLUS NOISE vs. FREQUENCY

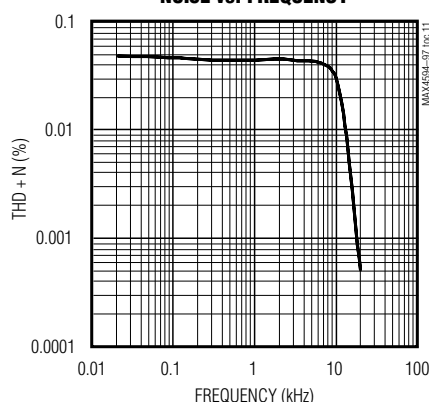

Pin Description

PIN				NAME	FUNCTION
MAX4594	MAX4595	MAX4596	MAX4597		
1	1	2	2	COM	Analog Switch, Common
2	—	4	—	NO	Analog Switch, Normally Open
3	3	3	3	GND	Ground
4	4	1	1	IN	Digital Control Input
5	5	5	5	V+	Positive Supply-Voltage
—	2	—	4	NC	Analog Switch, Normally Closed

Note: NO, NC, and COM pins are identical and interchangeable. Any pin may be considered as an input or an output; signals pass equally well in both directions.

Low-Voltage, Single-Supply, 10Ω SPST CMOS Analog Switches

Applications Information

Analog Signal Levels

Analog signals can range over the supply voltage (V_+ to GND) with on-resistance changing very little over the entire range (see *Typical Operating Characteristics*). The MAX4594–MAX4597 are bidirectional, so the NO, NC, and COM pins can be used either as inputs or outputs.

Power-Supply Sequencing and Overvoltage Protection

Proper power-supply sequencing is recommended for all CMOS devices. Always apply V_+ before applying analog signals or logic inputs, especially if the analog or logic signals are not current limited. If this sequencing is not possible, and if the analog or logic inputs are not current limited to $<20\text{mA}$, add a small-signal diode (D1) as shown in Figure 1. If the analog signal can dip below GND, add D2. Adding protection diodes reduces the analog signal range to a diode drop (about 0.7V) below V_+ for D1 or to a diode drop above ground for D2. The addition of diodes does not affect leakage. On-resistance increases by a small amount at low supply voltages. Maximum supply voltage (V_+) must not exceed 6V.

Protection diodes D1 and D2 also protect against some overvoltage situations. A fault voltage up to the absolute maximum rating at an analog signal input does not damage the device, even if the supply voltage is below the signal voltage.

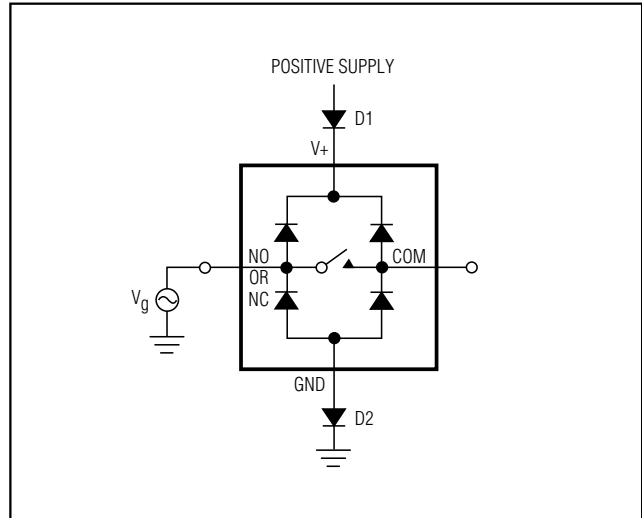

Figure 1. Overvoltage Protection Using Two External Blocking Diodes

Chip Information

TRANSISTOR COUNT: 50

Test Circuits/Timing Diagrams

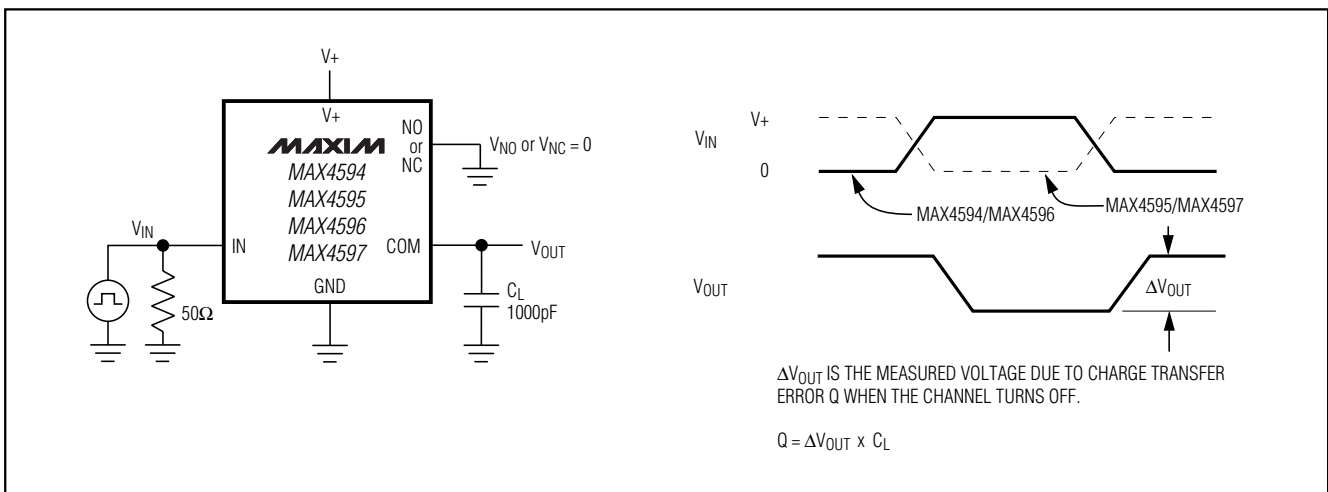

Figure 2. Charge Injection

Low-Voltage, Single-Supply, 10Ω SPST CMOS Analog Switches

Test Circuits/Timing Diagrams (continued)

MAX4594-MAX4597

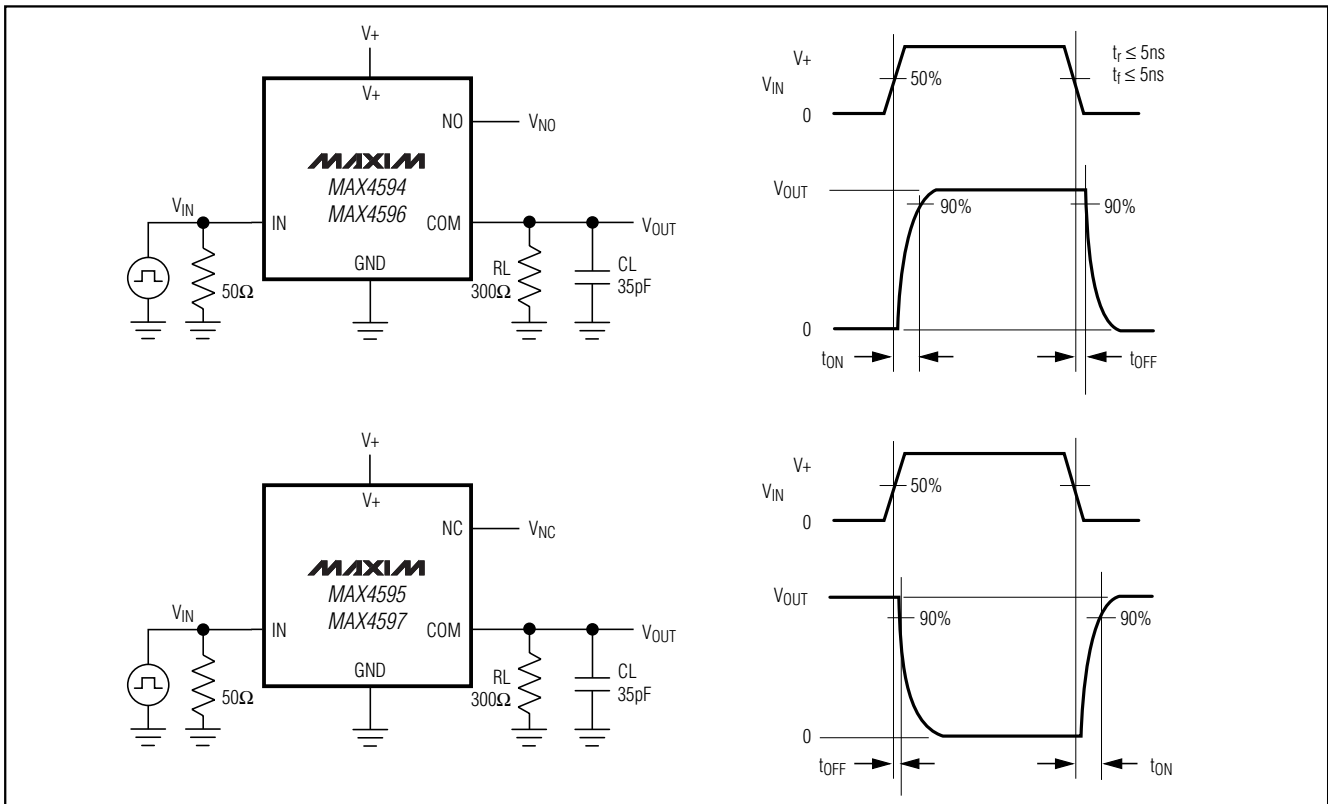

Figure 3. Switching Times

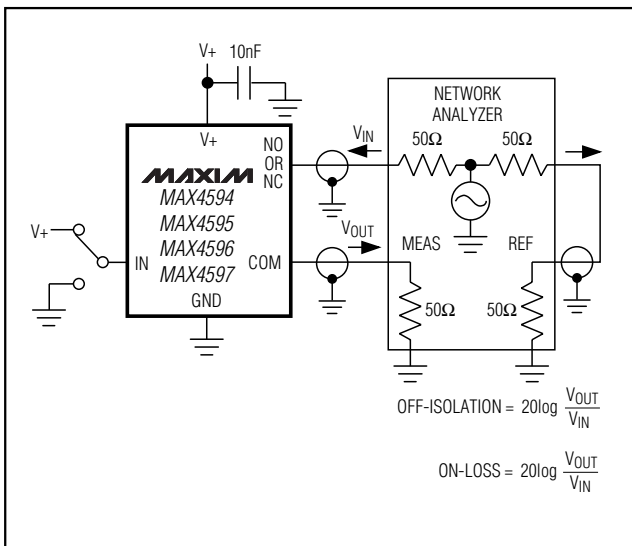

Figure 4. Off-Isolation and On-Channel Bandwidth

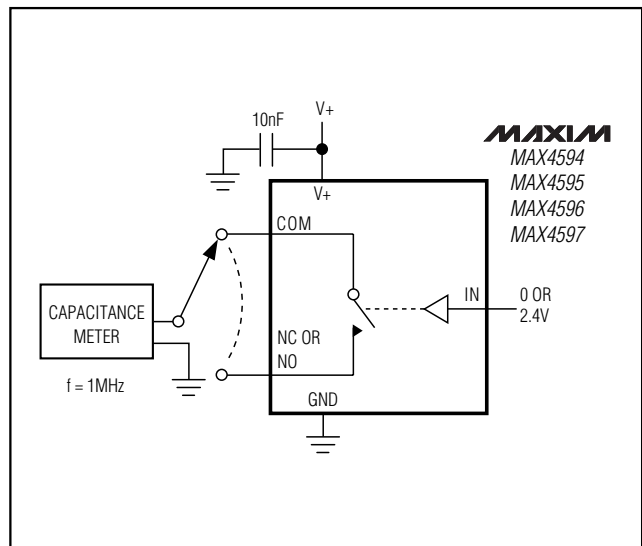
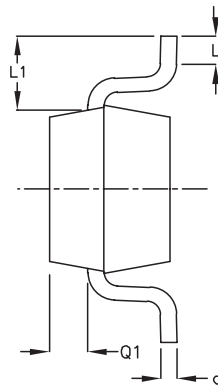
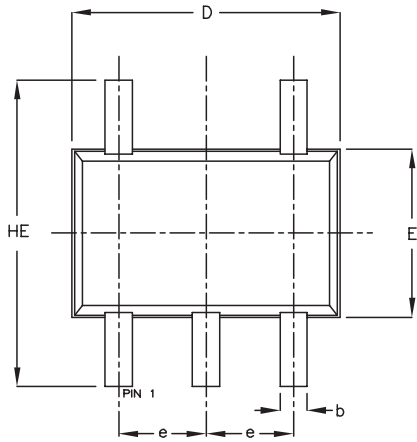

Figure 5. Channel On-/Off-Capacitance

Low-Voltage, Single-Supply, 10Ω SPST CMOS Analog Switches

Package Information

SC70, 5LEPS



SYMBOL	MIN	MAX
e	0.65	BSC
D	1.80	2.20
b	0.15	0.30
E	1.15	1.35
HE	1.80	2.40
Q1	0.10	0.40
A2	0.80	1.00
A1	0.00	0.10
A	0.80	1.10
c	0.10	0.18
L	0.10	0.30
L1	0.425	TYP.

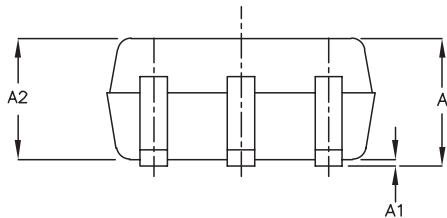

NOTE:

1. ALL DIMENSIONS ARE IN MILLIMETERS
2. DIMENSIONS ARE INCLUSIVE OF PLATING
3. DIMENSIONS ARE EXCLUSIVE OF MOLD FLASH & METAL BURR
4. ALL SPECIFICATIONS COMPLY TO EIAJ SC70
5. COPLANARITY 4 MILS. MAX.

MAXIM		
<small>PROPRIETARY INFORMATION</small>		
<small>TITLE:</small>		
PACKAGE OUTLINE, SC70, 5L		
<small>APPROVAL</small>	<small>DOCUMENT CONTROL NO.</small>	<small>REV</small>
	21-0076	B 1/1

Maxim cannot assume responsibility for use of any circuitry other than circuitry entirely embodied in a Maxim product. No circuit patent licenses are implied. Maxim reserves the right to change the circuitry and specifications without notice at any time.

8 Maxim Integrated Products, 120 San Gabriel Drive, Sunnyvale, CA 94086 (408) 737-7600