



**Integrated
Circuit
Systems, Inc.**

ICS9250-10

Preliminary Product Preview

Frequency Timing Generator for Pentium II Systems

General Description

The ICS9250-10 is a single chip clock for Intel Pentium II. It provides all necessary clock signals for such a system.

Spread spectrum may be enabled through I²C programming. Spread spectrum typically reduces EMI by 8dB to 10 dB. This simplifies EMI qualification without resorting to board design iterations or costly shielding. The ICS9250-10 employs a proprietary closed loop design, which tightly controls the percentage of spreading over process and temperature variations.

Features

- Generates the following system clocks:
 - 3 CPU (2.5V) 66.6/100 MHz (up to 133MHz through I²C selection)
 - 9 SDRAM (3.3V) up to 133MHz
 - 8 PCI (3.3 V) @33.3MHz
 - 2 IOAPIC (2.5V) @16.67 or 33.3MHz
 - 2 Hublink clocks (3.3 V) @ 66.6 MHz
 - 2 USB (3.3V) @ 48 MHz (Non spread spectrum)
 - 1 REF (3.3V) @ 14.318 MHz
- Supports spread spectrum modulation, down spread 0 to -0.5%
- I²C support for power management
- Efficient power management scheme through PD#
- Uses external 14.138 MHz crystal

Block Diagram

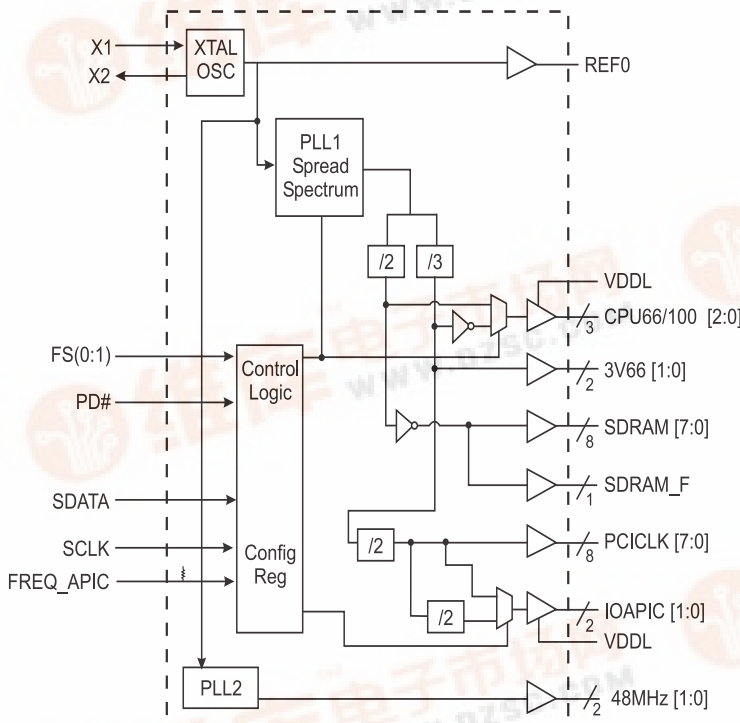

Pin Configuration

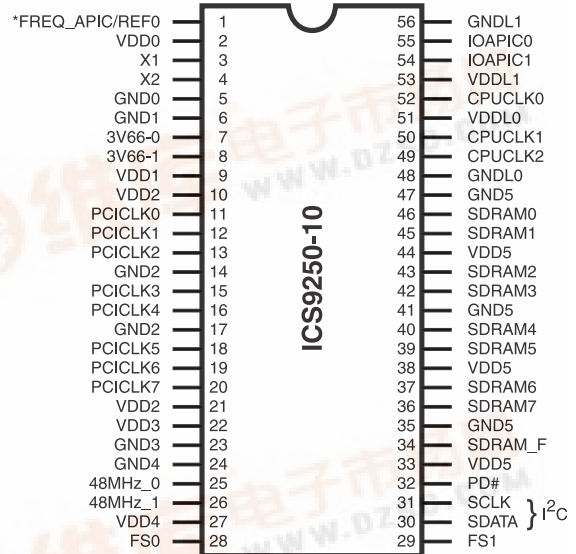

56-Pin 300 mil SSOP

*60K ohm pull-up to VDD on indicated inputs.

Power Groups

- VDD0, GND0 = REF & Crystal
- VDD1, GND1 = 3V66 [1:0]
- VDD2, GND2 = PCICLK [7:0]
- VDD3, GND3 = PLL core
- VDD4, GND4 = 48MHz [1:0]
- VDD5, GND5 = SDRAM_F, SDRAM [7:0]
- VDDL0, GNDL0 = CPUCLK [2:0]
- VDDL1, GNDL1 = IOAPIC [1:0]

ICS9250-10



Preliminary Product Preview

Pin Descriptions

PIN NUMBER	PIN NAME	TYPE	DESCRIPTION
1	FREQ_APIC	IN	Latched input at Power On. this determines the IOAPIC frequency. When a "0" is latched, IOAPIC Freq=16.67MHz When "1" is latched, IOAPIC Freq=33.3MHz This pin has a 60K internal pull-up.
	REF0	OUT	3.3V, 14.318MHz reference clock output.
3	X1	IN	Crystal input, has internal load cap (33pF) and feedback resistor from X2
4	X2	OUT	Crystal output, nominally 14.318MHz. Has internal load cap (33pF)
5, 6, 14, 17, 23, 24, 35, 41, 47	GND (0:5)	PWR	Ground pins for 3.3V supply
8, 7	3V66 [1:0]	OUT	3.3V Fixed 66MHz clock outputs for HUB
2, 9, 10, 21, 22, 27, 33, 38, 44	VDD (0:5)	PWR	3.3V power supply
20,19,18,16, 15,13,12,11	PCICLK[7:0]	OUT	3.3V PCI clock outputs, with Synchronous CPUCLKS
25, 26	48MHz (0:1)	OUT	3.3V Fixed 48MHz clock outputs for USB
28, 29	FS (0:1)	IN	Function Select pins. Determines CPU frequency, all output functionality. Please refer to Functionality table on page 3.
30	SDATA	IN	Data input for I ² C serial input.
31	SCLK	IN	Clock input of I ² C input
32	PD#	IN	Asynchronous active low input pin used to power down the device into a low power state. The internal clocks are disabled and the VCO and the crystal are stopped. The latency of the power down will not be greater than 3ms.
36, 37, 39, 40, 42, 43, 45, 46	SDRAM [7:0]	OUT	3.3V output running 100MHz. All SDRAM outputs can be turned off through I ² C
34	SDRAM_F	OUT	3.3V free running 100MHz SDRAM not affected by I ² C
56,48	GNDL [1:0]	PWR	Ground for 2.5V power supply for CPU & APIC
49,50,52	CPUCLK [2:0]	OUT	2.5V Host bus clock output. 66MHz or 100MHz depending on FS (0:1) pins Refer page 3.
51, 53	VDDL (0:1)	PWR	2.5V power supply for CPU & IOAPIC
54, 55	IOAPIC [1:0]	OUT	2.5V clock outputs running at 16.67MHz or 33.3MHz.



Functionality Table

FS1	FS0	CPU	SDRAM	3V66	PCICLK	48MHz	REF0	IOAPIC	Notes
0	0	Hi-Z	Hi-Z	Hi-Z	Hi-Z	Hi-Z	Hi-Z	Hi-Z	Tristate
0	1	TCLK/2	TCLK/4	TCLK/4	TCLK/8	TCLK/2	TCLK	TCLK/16	Test Mode
1	0	66 MHz	100 MHz	66 MHz	33 MHz	48 MHz	14.318MHz	16.67MHz	
1	1	100 MHz	100 MHz	66 MHz	33MHz	48 MHz	14.318MHZ	16.67MHz	

Clock Enable Configuration

PD#	CPUCLK	SDRAM	IOAPIC	66MHz	PCICLK	REF, 48MHz	Osc	VCOs
0	LOW	LOW	LOW	LOW	LOW	LOW	OFF	OFF
1	ON	ON	ON	ON	ON	ON	ON	ON

Select Functions

FS1	FS0	Notes
0	0	Tristate
0	1	Test Mode
1	0	Active CPU = 66MHz
1	1	Active CPU = 100MHz

ICS9250-10

Preliminary Product Preview



Power Down Waveform

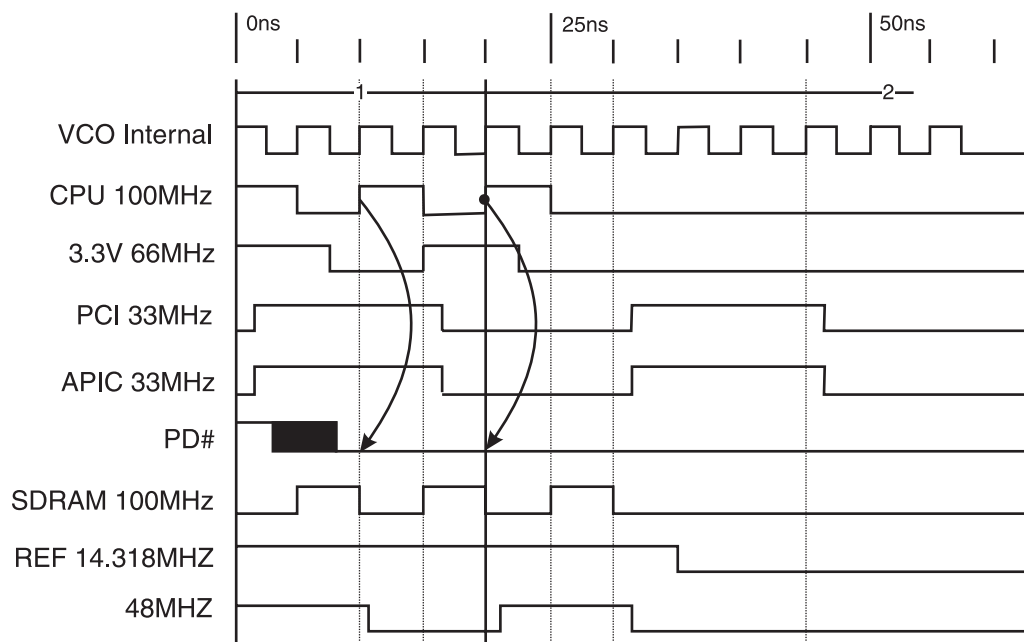

Note

1. After PD# is sampled active (Low) for 2 consecutive rising edges of CPUCLKs, all the output clocks are driven Low on their next High to Low transition.
2. Power-up latency <3ms.
3. Waveform shown for 100MHz

Maximum Allowed Current

810E Condition	Max 2.5V supply consumption Max discrete cap loads, Vddq2 = 2.625V All static inputs = Vddq3 or GND	Max 2.5V supply consumption Max discrete cap loads, Vddq2 = 3.465V All static inputs = Vddq3 or GND
Powerdown Mode (PWRDWN# = 0)	10mA	10mA
Full Active 66MHz SEL1, 0 = 10	70mA	280mA
Full Active 100MHz SEL1, 0 = 11	100mA	280mA



General I²C serial interface information

The information in this section assumes familiarity with I²C programming. For more information, contact ICS for an I²C programming application note.

How to Write:

- Controller (host) sends a start bit.
- Controller (host) sends the write address D2_(H)
- ICS clock will **acknowledge**
- Controller (host) sends a dummy command code
- ICS clock will **acknowledge**
- Controller (host) sends a dummy byte count
- ICS clock will **acknowledge**
- Controller (host) starts sending first byte (Byte 0) through byte 5
- ICS clock will **acknowledge** each byte *one at a time*.
- Controller (host) sends a Stop bit

How to Write:	
Controller (Host)	ICS (Slave/Receiver)
Start Bit	
Address D2 _(H)	
	ACK
Dummy Command Code	
	ACK
Dummy Byte Count	
	ACK
Byte 0	
	ACK
Byte 1	
	ACK
Byte 2	
	ACK
Byte 3	
	ACK
Byte 4	
	ACK
Byte 5	
	ACK
Stop Bit	

How to Read:

- Controller (host) will send start bit.
- Controller (host) sends the read address D3_(H)
- ICS clock will **acknowledge**
- ICS clock will send the **byte count**
- Controller (host) acknowledges
- ICS clock sends first byte (**Byte 0**) through **byte 5**
- Controller (host) will need to acknowledge each byte
- Controller (host) will send a stop bit

How to Read:	
Controller (Host)	ICS (Slave/Receiver)
Start Bit	
Address D3 _(H)	
	ACK
	Byte Count
ACK	
	Byte 0
ACK	
	Byte 1
ACK	
	Byte 2
ACK	
	Byte 3
ACK	
	Byte 4
ACK	
	Byte 5
ACK	
Stop Bit	

Notes:

1. The ICS clock generator is a slave/receiver, I²C component. It can read back the data stored in the latches for verification. **Read-Back will support Intel PIIX4 "Block-Read" protocol.**
2. The data transfer rate supported by this clock generator is 100K bits/sec or less (standard mode)
3. The input is operating at 3.3V logic levels.
4. The data byte format is 8 bit bytes.
5. To simplify the clock generator I²C interface, the protocol is set to use only "**Block-Writes**" from the controller. The bytes must be accessed in sequential order from lowest to highest byte with the ability to stop after any complete byte has been transferred. The Command code and Byte count shown above must be sent, but the data is ignored for those two bytes. The data is loaded until a Stop sequence is issued.
6. At power-on, all registers are set to a default condition, as shown.

ICS9250-10



Preliminary Product Preview

Byte 5: ICS Reserved Functionality and frequency select register (Default=0)

Bit	Description								PWD
Bit7	ICS RESERVED BIT (Needs to be 0 clock to operate normal)								0
Bit6	ICS RESERVED BIT (Needs to be 0 clock to operate normal)								0
Bit5	ICS RESERVED BIT (Needs to be 0 clock to operate normal)								0
Bit (4,3,0)	Bit (4,3,0)				CPUCLK MHz	SDRAM MHz	3V66 MHz	PCICLK MHz	XXXX Note 1
	FS0 (HW)	SEL3 (Bit4)	SEL2 (Bit3)	SEL1 (Bit0)					
	0	0	0	0	66.67	100	66.67	33.33	
	0	0	0	1	70.67	106	70.67	35.33	
	0	0	1	0	74.66	112	74.67	37.33	
	0	0	1	1	82.66	124	82.66	41.33	
	0	1	0	0	63.5	95.25	63.5	31.75	
	0	1	0	1	68.67	103	68.67	34.33	
	0	1	1	0	72.67	109	72.67	36.33	
	0	1	1	1	88.66	133	88.66	44.33	
	1	0	0	0	100	100	66.67	33.33	
	1	0	0	1	106	106	70.67	35.33	
	1	0	1	0	112	112	74.67	37.33	
	1	0	1	1	124	124	82.66	41.33	
	1	1	0	0	95.25	95.25	63.5	31.75	
	1	1	0	1	103	103	68.67	34.33	
1	1	1	0	109	109	72.67	36.33		
1	1	1	1	133	133	88.66	44.33		
Bit2	Not used (Needs to be 1 for normal clock operation)								1
Bit1	Not used (Needs to be 1 for normal clock operation)								1

Note1: Default at power-up will be for latched logic inputs to define frequency, as displayed by Bit 3.



Byte 0: Control Register (1 = enable, 0 = disable)

Bit	Pin#	Name	PWD	Description
Bit 7		Reserved	0	(Active/Inactive)
Bit 6		Reserved	0	(Active/Inactive)
Bit 5		Reserved	0	(Active/Inactive)
Bit 4		Reserved	1	(Active/Inactive)
Bit 3		SpreadSpectrum (1=On/0=Off)	1	(Active/Inactive)
Bit 2	26	48MHz 1	1	(Active/Inactive)
Bit 1	25	48MHz 0	1	(Active/Inactive)
Bit 0	49	CPUCLK2	1	(Active/Inactive)

Byte 1: Control Register (1 = enable, 0 = disable)

Bit	Pin#	Name	PWD	Description
Bit 7	36	SDRAM7	1	(Active/Inactive)
Bit 6	37	SDRAM6	1	(Active/Inactive)
Bit 5	39	SDRAM5	1	(Active/Inactive)
Bit 4	40	SDRAM4	1	(Active/Inactive)
Bit 3	42	SDRAM3	1	(Active/Inactive)
Bit 2	43	SDRAM2	1	(Active/Inactive)
Bit 1	45	SDRAM1	1	(Active/Inactive)
Bit 0	46	SDRAM0	1	(Active/Inactive)

Byte 2: Control Register (1 = enable, 0 = disable)

Bit	Pin#	Name	PWD	Description
Bit 7	20	PCICLK7	1	(Active/Inactive)
Bit 6	19	PCICLK6	1	(Active/Inactive)
Bit 5	18	PCICLK5	1	(Active/Inactive)
Bit 4	16	PCICLK4	1	(Active/Inactive)
Bit 3	15	PCICLK3	1	(Active/Inactive)
Bit 2	13	PCICLK2	1	(Active/Inactive)
Bit 1	12	PCICLK1	1	(Active/Inactive)
Bit 0	-	Reserved	0	(Active/Inactive)

Notes:

1. Inactive means outputs are held LOW and are disabled from switching. These outputs are designed to be configured at power-on and are not expected to be configured during the normal modes of operation.
 2. PWD = Power on Default
-

ICS9250-10



Preliminary Product Preview

Byte 3: Reserved Register

(1 = enable, 0 = disable)

Bit	Pin#	Name	PWD	Description
Bit 7	-	Reserved	0	(Active/Inactive)
Bit 6	-	Reserved	0	(Active/Inactive)
Bit 5	-	Reserved	0	(Active/Inactive)
Bit 4	-	Reserved	0	(Active/Inactive)
Bit 3	-	Reserved	0	(Active/Inactive)
Bit 2	-	Reserved	0	(Active/Inactive)
Bit 1	-	Reserved	0	(Active/Inactive)
Bit 0	-	Reserved	0	(Active/Inactive)

Byte 4: Reserved Register

(1 = enable, 0 = disable)

Bit	Pin#	Name	PWD	Description
Bit 7	-	Reserved	0	(Active/Inactive)
Bit 6	-	Reserved	0	(Active/Inactive)
Bit 5	-	Reserved	0	(Active/Inactive)
Bit 4	-	Reserved	0	(Active/Inactive)
Bit 3	-	Reserved	0	(Active/Inactive)
Bit 2	-	Reserved	0	(Active/Inactive)
Bit 1	-	Reserved	0	(Active/Inactive)
Bit 0	-	Reserved	0	(Active/Inactive)

Notes:

1. Inactive means outputs are held LOW and are disabled from switching. These outputs are designed to be configured at power-on and are not expected to be configured during the normal modes of operation.
 2. PWD = Power on Default
-



Absolute Maximum Ratings

Core Supply Voltage	4.6 V
I/O Supply Voltage	3.6V
Logic Inputs	GND–0.5 V to V _{DD} +0.5 V
Ambient Operating Temperature	0°C to +70°C
Storage Temperature	–65°C to +150°C

Stresses above those listed under *Absolute Maximum Ratings* may cause permanent damage to the device. These ratings are stress specifications only and functional operation of the device at these or any other conditions above those listed in the operational sections of the specifications is not implied. Exposure to absolute maximum rating conditions for extended periods may affect product reliability.

Electrical Characteristics - Input/Supply/Common Output Parameters

T_A = 0 - 70C; Supply Voltage V_{DD} = 3.3 V ±5%, VDDL=2.5 V± 5%(unless otherwise stated)

PARAMETER	SYMBOL	CONDITIONS	MIN	TYP	MAX	UNITS
Input High Voltage	V _{IH}		2		V _{DD} +0.3	V
Input Low Voltage	V _{IL}		V _{SS} -0.3		0.8	V
Input High Current	I _{IH}	V _{IN} = V _{DD}	-5		5	μA
Input Low Current	I _{IL1}	V _{IN} = 0 V; Inputs with no pull-up resistors	-5	2.0		μA
Input Low Current	I _{IL2}	V _{IN} = 0 V; Inputs with pull-up resistors	-200	-100		μA
Operating Supply Current	I _{DD3.3OP}	C _L = 0 pF; Select @ 66M		60	100	mA
Power Down Supply Current	I _{DD3.3PD}	C _L = 0 pF; With input address to V _{DD} or GND		400	600	μA
Input frequency	F _i	V _{DD} = 3.3 V;		14.318		MHz
Pin Inductance	L _{pin}				7	nH
Input Capacitance ¹	C _{IN}	Logic Inputs			5	pF
	C _{out}	Out put pin capacitance			6	pF
	C _{INX}	X1 & X2 pins	27		45	pF
Transition Time ¹	T _{trans}	To 1st crossing of target Freq.			3	mS
Settling Time ¹	T _s	From 1st crossing to 1% target Freq.			3	mS
Clk Stabilization ¹	T _{STAB}	From V _{DD} = 3.3 V to 1% target Freq.			3	mS
Delay	t _{PZH} ,t _{PZH}	output enable delay (all outputs)	1		10	nS
	t _{PLZ} ,t _{PZH}	output disable delay (all outputs)	1		10	nS

¹Guarenteed by design, not 100% tested in production.

ICS9250-10



Preliminary Product Preview

Electrical Characteristics - CPU

$T_A = 0 - 70^\circ\text{C}$, $V_{DD} = 2.5 \text{ V} \pm 5\%$; $C_L = 10 - 20 \text{ pF}$ (unless otherwise stated)

PARAMETER	SYMBOL	CONDITIONS	MIN	TYP	MAX	UNITS
Output Impedance	R_{DSP2B}^1	$V_O = V_{DD}*(0.5)$	13.5		45	Ω
Output Impedance	R_{DSN2B}^1	$V_O = V_{DD}*(0.5)$	13.5		45	Ω
Output High Voltage	V_{OH2B}	$I_{OH} = -1 \text{ mA}$	2			V
Output Low Voltage	V_{OL2B}	$I_{OL} = 1 \text{ mA}$			0.4	V
Output High Current	I_{OH2B}	$V_{OH@MIN} = 1.0 \text{ V}$, $V_{OH@MAX} = 2.375 \text{ V}$	-27		-27	mA
Output Low Current	I_{OL2B}	$V_{OL@MIN} = 1.2 \text{ V}$, $V_{OL@MAX} = 0.3 \text{ V}$	27		30	mA
Rise Time	t_{r2B}^1	$V_{OL} = 0.4 \text{ V}$, $V_{OH} = 2.0 \text{ V}$	0.4		1.6	ns
Fall Time	t_{f2B}^1	$V_{OH} = 0.4 \text{ V}$, $V_{OL} = 2.0 \text{ V}$	0.4		1.6	ns
Duty Cycle	d_{2B}^1	$V_T = 1.25 \text{ V}$	45	50	55	%
Skew	t_{sk2B}^1	$V_T = 1.25 \text{ V}$			175	ps
Jitter	$t_{jeye-cyc}^1$	$V_T = 1.25 \text{ V}$			250	ps

¹Guaranteed by design, not 100% tested in production.

Electrical Characteristics - 3V66

$T_A = 0 - 70^\circ\text{C}$; $V_{DD} = 3.3 \text{ V} \pm 5\%$; $C_L = 10-30 \text{ pF}$ (unless otherwise stated)

PARAMETER	SYMBOL	CONDITIONS	MIN	TYP	MAX	UNITS
Output Impedance	R_{DSP1}^1	$V_O = V_{DD}*(0.5)$	12		55	Ω
Output Impedance	R_{DSN1}^1	$V_O = V_{DD}*(0.5)$	12		55	Ω
Output High Voltage	V_{OH1}	$I_{OH} = -1 \text{ mA}$	2.4			V
Output Low Voltage	V_{OL1}	$I_{OL} = 1 \text{ mA}$			0.55	V
Output High Current	I_{OH1}	$V_{OH@MIN} = 1.0 \text{ V}$, $V_{OH@MAX} = 3.135 \text{ V}$	-33		-33	mA
Output Low Current	I_{OL1}	$V_{OL@MIN} = 1.95 \text{ V}$, $V_{OL@MAX} = 0.4$	30		38	mA
Rise Time	t_{r1}^1	$V_{OL} = 0.4 \text{ V}$, $V_{OH} = 2.4 \text{ V}$	0.5		2	ns
Fall Time	t_{f1}^1	$V_{OH} = 2.4 \text{ V}$, $V_{OL} = 0.4 \text{ V}$	0.5		2	ns
Duty Cycle	d_{11}^1	$V_T = 1.5 \text{ V}$	45		55	%
Skew	t_{sk1}^1	$V_T = 1.5 \text{ V}$			175	ps
Jitter	$t_{jeye-cyc}$	$V_T = 1.5 \text{ V}$			500	ps

¹Guaranteed by design, not 100% tested in production.



Electrical Characteristics - IOAPIC

$T_A = 0 - 70^\circ\text{C}$; $V_{DDL} = 2.5\text{ V} \pm 5\%$; $C_L = 10 - 20\text{ pF}$ (unless otherwise stated)

PARAMETER	SYMBOL	CONDITIONS	MIN	TYP	MAX	UNITS
Output Impedance	R_{DSP4B}^1	$V_O = V_{DD}^*(0.5)$	9		30	Ω
Output Impedance	R_{DSN4B}^1	$V_O = V_{DD}^*(0.5)$	9		30	Ω
Output High Voltage	V_{OH4B}	$I_{OH} = -5.5\text{ mA}$	2			V
Output Low Voltage	V_{OL4B}	$I_{OL} = 9.0\text{ mA}$			0.4	V
Output High Current	I_{OH4B}	$V_{OH@MIN} = 1.0\text{ V}$, $V_{OH@MAX} = 2.375\text{ V}$	-27		-27	mA
Output Low Current	I_{OL4B}	$V_{OL@MIN} = 1.2\text{ V}$, $V_{OL@MAX} = 0.3\text{ V}$	27		30	mA
Rise Time	t_{r4B}^1	$V_{OL} = 0.4\text{ V}$, $V_{OH} = 2.0\text{ V}$	0.4		1.6	ns
Fall Time	t_{f4B}^1	$V_{OH} = 2.0\text{ V}$, $V_{OL} = 0.4\text{ V}$	0.4		1.6	ns
Duty Cycle	d_{t4B}^1	$V_T = 1.25\text{ V}$	45		55	%
Jitter	$t_{j\text{cyc-cyc}}$	$V_T = 1.25\text{ V}$			500	ps
Skew	T_{sk4}^1				250	ps

¹Guaranteed by design, not 100% tested in production.

Electrical Characteristics - SDRAM

$T_A = 0 - 70^\circ\text{C}$; $V_{DD} = V_{DDL} = 3.3\text{ V} \pm 5\%$; $C_L = 20 - 30\text{ pF}$ (unless otherwise stated)

PARAMETER	SYMBOL	CONDITIONS	MIN	TYP	MAX	UNITS
Output Impedance	R_{DSP3}^1	$V_O = V_{DD}^*(0.5)$	10		24	Ω
Output Impedance	R_{DSN3}^1	$V_O = V_{DD}^*(0.5)$	10		24	Ω
Output High Voltage	V_{OH3}	$I_{OH} = -1\text{ mA}$	2.4			V
Output Low Voltage	V_{OL3}	$I_{OL} = 1\text{ mA}$			0.4	V
Output High Current	I_{OH3}	$V_{OH@MIN} = 2.0\text{ V}$, $V_{OH@MAX} = 3.135\text{ V}$	-54		-46	mA
Output Low Current	I_{OL3}	$V_{OL@MIN} = 1.0\text{ V}$, $V_{OL@MAX} = 0.4\text{ V}$	54		53	mA
Rise Time	T_{r3}^1	$V_{OL} = 0.4\text{ V}$, $V_{OH} = 2.4\text{ V}$	0.4		1.6	ns
Fall Time	T_{f3}^1	$V_{OH} = 2.4\text{ V}$, $V_{OL} = 0.4\text{ V}$	0.4		1.6	ns
Duty Cycle	D_{t3}^1	$V_T = 1.5\text{ V}$	45		55	%
Skew	T_{sk3}^1	$V_T = 1.5\text{ V}$			250	ps
Jitter	$t_{j\text{cyc-cyc}}$	$V_T = 1.5\text{ V}$			250	ps

¹Guaranteed by design, not 100% tested in production.

ICS9250-10



Preliminary Product Preview

Electrical Characteristics - PCI

$T_A = 0 - 70^\circ\text{C}$; $V_{DD} = 3.3 \text{ V} \pm 5\%$; $C_L = 10\text{-}30 \text{ pF}$ (unless otherwise stated)

PARAMETER	SYMBOL	CONDITIONS	MIN	TYP	MAX	UNITS
Output Impedance	R_{DSP1}^1	$V_O = V_{DD}^*(0.5)$	12		55	Ω
Output Impedance	R_{DSN1}^1	$V_O = V_{DD}^*(0.5)$	12		55	Ω
Output High Voltage	V_{OH1}	$I_{OH} = -1 \text{ mA}$	2.4			V
Output Low Voltage	V_{OL1}	$I_{OL} = 1 \text{ mA}$			0.55	V
Output High Current	I_{OH1}	$V_{OH@MIN} = 1.0 \text{ V}$, $V_{OH@MAX} = 3.135 \text{ V}$	-33		-33	mA
Output Low Current	I_{OL1}	$V_{OL@MIN} = 1.95 \text{ V}$, $V_{OL@MAX} = 0.4$	30		38	mA
Rise Time	t_{r1}^1	$V_{OL} = 0.4 \text{ V}$, $V_{OH} = 2.4 \text{ V}$	0.5		2	ns
Fall Time	t_{f1}^1	$V_{OH} = 2.4 \text{ V}$, $V_{OL} = 0.4 \text{ V}$	0.5		2	ns
Duty Cycle	d_{t1}^1	$V_T = 1.5 \text{ V}$	45		55	%
Skew	t_{sk1}^1	$V_T = 1.5 \text{ V}$			500	ps
Jitter	$t_{jycyc-cyc}^1$	$V_T = 1.5 \text{ V}$			500	ps

¹Guaranteed by design, not 100% tested in production.

Electrical Characteristics - REF, 48MHz_0 (Pin 25)

$T_A = 0 - 70^\circ\text{C}$; $V_{DD} = V_{DDL} = 3.3 \text{ V} \pm 5\%$; $C_L = 10\text{-}20 \text{ pF}$ (unless otherwise stated)

PARAMETER	SYMBOL	CONDITIONS	MIN	TYP	MAX	UNITS
Output Impedance	R_{DSP5}^1	$V_O = V_{DD}^*(0.5)$	20		60	Ω
Output Impedance	R_{DSN5}^1	$V_O = V_{DD}^*(0.5)$	20		60	Ω
Output High Voltage	V_{OH5}	$I_{OH} = 1 \text{ mA}$	2.4			V
Output Low Voltage	V_{OL5}	$I_{OL} = -1 \text{ mA}$			0.4	V
Output High Current	I_{OH5}	$V_{OH@MIN} = 1 \text{ V}$, $V_{OH@MAX} = 3.135 \text{ V}$	-29		-23	mA
Output Low Current	I_{OL5}	$V_{OL@MIN} = 1.95 \text{ V}$, $V_{OL@MAX} = 0.4 \text{ V}$	29		27	mA
Rise Time	t_{r5}^1	$V_{OL} = 0.4 \text{ V}$, $V_{OH} = 2.4 \text{ V}$		1.8	4	ns
Fall Time	t_{f5}^1	$V_{OH} = 2.4 \text{ V}$, $V_{OL} = 0.4 \text{ V}$		1.7	4	ns
Duty Cycle	d_{t5}^1	$V_T = 1.5 \text{ V}$	45		55	%
Jitter	$t_{jycyc-cyc}^1$	$V_T = 1.5 \text{ V}$; Fixed Clocks			500	ps
Jitter	$t_{jycyc-cyc}^1$	$V_T = 1.5 \text{ V}$; Ref Clocks			1000	ps
Skew	T_{sk}	$V_T = 1.5 \text{ V}$			250	ps

¹Guaranteed by design, not 100% tested in production.



Electrical Characteristics - 48MHz_1 (Pin 26)

$T_A = 0 - 70^\circ\text{C}$; $V_{DD} = V_{DDL} = 3.3 \text{ V} \pm 5\%$; $C_L = 20 - 30 \text{ pF}$ (unless otherwise stated)

PARAMETER	SYMBOL	CONDITIONS	MIN	TYP	MAX	UNITS
Output Impedance	R_{DSP3}^1	$V_O = V_{DD}^*(0.5)$	10		24	Ω
Output Impedance	R_{DSN3}^1	$V_O = V_{DD}^*(0.5)$	10		24	Ω
Output High Voltage	V_{OH3}	$I_{OH} = -1 \text{ mA}$	2.4			V
Output Low Voltage	V_{OL3}	$I_{OL} = 1 \text{ mA}$			0.4	V
Output High Current	I_{OH3}	$V_{OH@MIN} = 2.0 \text{ V}, V_{OH@MAX} = 3.135 \text{ V}$	-54		-46	mA
Output Low Current	I_{OL3}	$V_{OL@MIN} = 1.0 \text{ V}, V_{OL@MAX} = 0.4 \text{ V}$	54		53	mA
Rise Time	T_{r3}^1	$V_{OL} = 0.4 \text{ V}, V_{OH} = 2.4 \text{ V}$	0.4		1.6	ns
Fall Time	T_{f3}^1	$V_{OH} = 2.4 \text{ V}, V_{OL} = 0.4 \text{ V}$	0.4		1.6	ns
Duty Cycle	D_{t3}^1	$V_T = 1.5 \text{ V}$	45		55	%
Skew	T_{sk3}^1	$V_T = 1.5 \text{ V}$			250	ps
Jitter	$t_{j\text{cyc-cyc}}$	$V_T = 1.5 \text{ V}$			250	ps

¹Guaranteed by design, not 100% tested in production.

ICS9250-10



Preliminary Product Preview

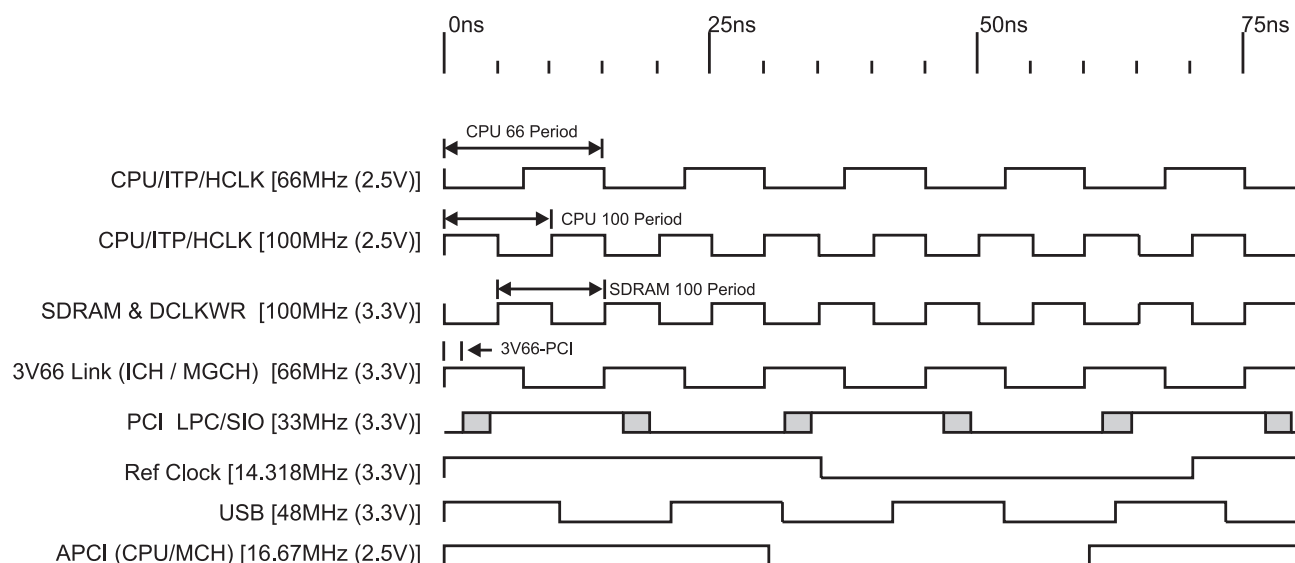

Group Offset Waveforms

Group Skews at Common Transition Edges: (CPU = 66MHz)

CPU & IOAPIC load (lumped) = 20pf; PCI, SDRAM, 3V66 LOAD (LUMPED) = 30pf.

GROUP	SYMBOL	CONDITIONS	MIN	TYP	MAX	UNITS
CPU to 3V66	$S_{\text{CPU1-3V66}}$	CPU @ 1.25V, 3V66 @ 1.5V (Note: 180° offset between CPU & 66MHz)	0		500	ps
CPU to SDRAM	$S_{\text{CPU2-SDRAM}}$	CPU @ 1.25V, SDRAM @ 1.5V (Note: 180° offset between CPU & 66MHz)	0		500	ps
3V66 to PCI	$S_{\text{3V66-PCI}}$	3V66 @ 1.5V, PCI @ 1.5V	1.5		4	ns
IOAPIC to PCI	$S_{\text{IOAPIC-PCI}}$	IOAPIC @ 1.25V, PCI @ 1.5V	0		500	ps

¹Guaranteed by design, not 100% tested in production.

Group Skews at Common Transition Edges: (CPU = 100MHz)

CPU & IOAPIC load (lumped) = 20pf; PCI, SDRAM, 3V66 LOAD (LUMPED) = 30pf.

GROUP	SYMBOL	CONDITIONS	MIN	TYP	MAX	UNITS
CPU to 3V66	$S_{\text{CPU1-3V66}}$	CPU @ 1.25V, 3V66 @ 1.5V (Note: 180° offset between CPU & 100MHz)	0		500	ps
CPU to SDRAM	$S_{\text{CPU2-SDRAM}}$	CPU @ 1.25V, SDRAM @ 1.5V (Note: 180° offset between CPU & 100MHz)	0		500	ps
3V66 to PCI	$S_{\text{3V66-PCI}}$	3V66 @ 1.5V, PCI @ 1.5V	1.5		4	ns
IOAPIC to PCI	$S_{\text{IOAPIC-PCI}}$	IOAPIC @ 1.25V, PCI @ 1.5V	0		500	ps

¹Guaranteed by design, not 100% tested in production.



General Layout Precautions:

- 1) Use a ground plane on the top layer of the PCB in all areas not used by traces.
- 2) Make all power traces and vias as wide as possible to lower inductance.

Notes:

- 1) All clock outputs should have series terminating resistor. Not shown in all places to improve readability of diagram.
- 2) 47 ohm / 56pf RC termination should be used on all over 50MHz outputs.
- 3) Optional crystal load capacitors are recommended.

Capacitor Values:

C1, C2 : Crystal load values determined by user

C3 : 100pF ceramic

All unmarked capacitors are 0.01 μ F ceramic

Connections to VDD:

- Best
- Okay
- Avoid
- Avoid

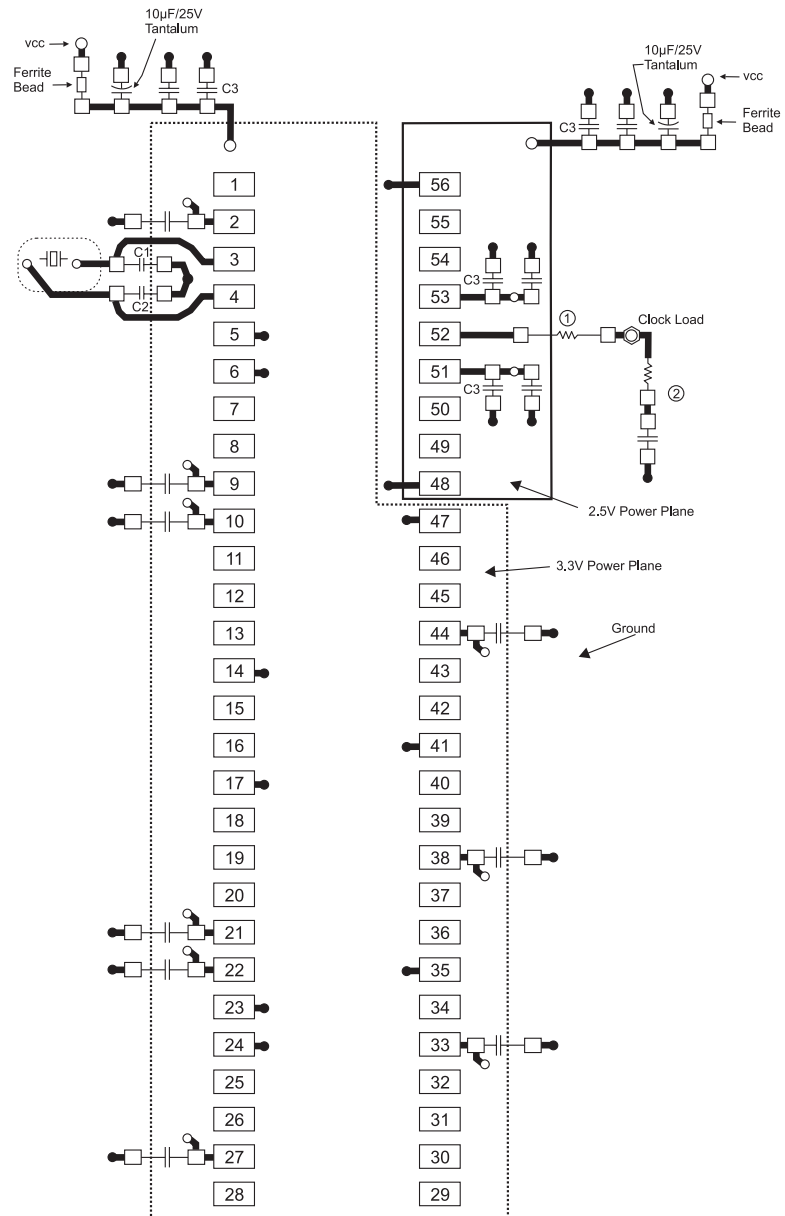

- = Ground Plane Connection
- = Power Plane Connection
- = Solder Pads
- ⊗ = Clock Load

ICS9250-10

Preliminary Product Preview

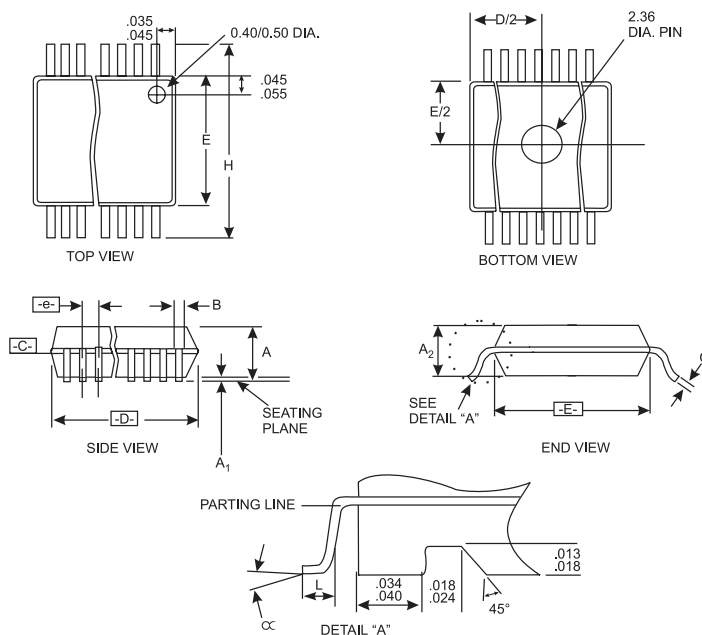

SSOP Package

SYMBOL	COMMON DIMENSIONS			VARIATIONS	D			N
	MIN.	NOM.	MAX.		MIN.	NOM.	MAX.	
A	.095	.101	.110	AC	.620	.625	.630	48
A1	.008	.012	.016	AD	.720	.725	.730	56
A2	.088	.090	.092					
B	.008	.010	.0135					
C	.005	.006	.0085					
D	See Variations							
E	.292	.296	.299					
e	0.025 BSC							
H	.400	.406	.410					
h	.010	.013	.016					
L	.024	.032	.040					
N	See Variations							
∞	0°	5°	8°					
X	.085	.093	.100					

Ordering Information

ICS9250yF-10

Example:

ICS XXXX y F - PPP

