

NEC

MOS INTEGRATED CIRCUIT
 μ PD4482162, 4482182, 4482322, 4482362

8M-BIT CMOS SYNCHRONOUS FAST SRAM
PIPELINED OPERATION
SINGLE CYCLE DESELECT

Description

The μ PD4482162 is a 524,288-word by 16-bit, the μ PD4482182 is a 524,288-word by 18-bit, μ PD4482322 is a 262,144-word by 32-bit and the μ PD4482362 is a 262,144-word by 36-bit synchronous static RAM fabricated with advanced CMOS technology using Full-CMOS six-transistor memory cell.

The μ PD4482162, μ PD4482182, μ PD4482322 and μ PD4482362 integrates unique synchronous peripheral circuitry, 2-bit burst counter and output buffer as well as SRAM core. All input registers are controlled by a positive edge of the single clock input (CLK).

The μ PD4482162, μ PD4482182, μ PD4482322 and μ PD4482362 are suitable for applications which require synchronous operation, high speed, low voltage, high density and wide bit configuration, such as cache and buffer memory.

ZZ has to be set LOW at the normal operation. When ZZ is set HIGH, the SRAM enters Power Down State ("Sleep"). In the "Sleep" state, the SRAM internal state is preserved. When ZZ is set LOW again, the SRAM resumes normal operation.

The μ PD4482162, μ PD4482182, μ PD4482322 and μ PD4482362 are packaged in 100-pin PLASTIC LQFP with a 1.4 mm package thickness for high density and low capacitive loading.

Features

- 3.3 V or 2.5 V core supply
- Synchronous operation
- ★ • Operating temperature : $T_A = 0$ to 70 °C (-A44, -A50, -A60, -C60)
 $T_A = -40$ to $+85$ °C (-A44Y, -A50Y, -A60Y, -C60Y)
- Internally self-timed write control
- Burst read / write : Interleaved burst and linear burst sequence
- Fully registered inputs and outputs for pipelined operation
- Single-Cycle deselect timing
- All registers triggered off positive clock edge
- 3.3 V or 2.5 V LVTTTL Compatible : All inputs and outputs
- Fast clock access time : 2.8 ns (225 MHz), 3.1 ns (200 MHz), 3.5 ns (167 MHz)
- Asynchronous output enable : /G
- Burst sequence selectable : MODE
- Sleep mode : ZZ (ZZ = Open or Low : Normal operation)
- Separate byte write enable : /BW1 to /BW4, /BWE (μ PD4482322, μ PD4482362)
/BW1, /BW2, /BWE (μ PD4482162, μ PD4482182)
- Global write enable : /GW
- Three chip enables for easy depth expansion
- Common I/O using three state outputs

The information in this document is subject to change without notice. Before using this document, please confirm that this is the latest version.
Not all products and/or types are available in every country. Please check with an NEC Electronics sales representative for availability and additional information.

★ Ordering Information

Part number	Access Time ns	Clock Frequency MHz	Core Supply Voltage V	I/O Interface	Operating Temperature °C	Package
μPD4482162GF-A44	2.8	225	3.3 ± 0.165	3.3 V LVTTTL ^{Note}	0 to 70	100-pin PLASTIC LQFP (14 × 20)
μPD4482162GF-A50	3.1	200		3.3 V or 2.5 V LVTTTL		
μPD4482162GF-A60	3.5	167				
μPD4482182GF-A44	2.8	225		3.3 V LVTTTL ^{Note}		
μPD4482182GF-A50	3.1	200		3.3 V or 2.5 V LVTTTL		
μPD4482182GF-A60	3.5	167				
μPD4482322GF-A44	2.8	225		3.3 V LVTTTL ^{Note}		
μPD4482322GF-A50	3.1	200		3.3 V or 2.5 V LVTTTL		
μPD4482322GF-A60	3.5	167				
μPD4482362GF-A44	2.8	225		3.3 V LVTTTL ^{Note}		
μPD4482362GF-A50	3.1	200		3.3 V or 2.5 V LVTTTL		
μPD4482362GF-A60	3.5	167				
μPD4482162GF-C60	3.5	167	2.5 ± 0.125	2.5 V LVTTTL	-40 to +85	
μPD4482182GF-C60	3.5	167				
μPD4482322GF-C60	3.5	167				
μPD4482362GF-C60	3.5	167				
μPD4482162GF-A44Y	2.8	225	3.3 ± 0.165	3.3 V LVTTTL ^{Note}		
μPD4482162GF-A50Y	3.1	200		3.3 V or 2.5 V LVTTTL		
μPD4482162GF-A60Y	3.5	167				
μPD4482182GF-A44Y	2.8	225		3.3 V LVTTTL ^{Note}		
μPD4482182GF-A50Y	3.1	200		3.3 V or 2.5 V LVTTTL		
μPD4482182GF-A60Y	3.5	167				
μPD4482322GF-A44Y	2.8	225		3.3 V LVTTTL ^{Note}		
μPD4482322GF-A50Y	3.1	200		3.3 V or 2.5 V LVTTTL		
μPD4482322GF-A60Y	3.5	167				
μPD4482362GF-A44Y	2.8	225		3.3 V LVTTTL ^{Note}		
μPD4482362GF-A50Y	3.1	200		3.3 V or 2.5 V LVTTTL		
μPD4482362GF-A60Y	3.5	167				
μPD4482162GF-C60Y	3.5	167	2.5 ± 0.125	2.5 V LVTTTL		
μPD4482182GF-C60Y	3.5	167				
μPD4482322GF-C60Y	3.5	167				
μPD4482362GF-C60Y	3.5	167				

Note Although 2.5V LVTTTL interface can also be used, a performance becomes equivalent to 167 MHz.

Pin Identification (μPD4482162GF, μPD4482182GF)

Symbol	Pin No.	Description
A0 to A18	37, 36, 35, 34, 33, 32, 100, 99, 82, 81, 44, 45, 46, 47, 48, 49, 50, 43, 80	Synchronous Address Input
I/O1 to I/O16	58, 59, 62, 63, 68, 69, 72, 73, 8, 9, 12, 13, 18, 19, 22, 23	Synchronous Data In, Synchronous / Asynchronous Data Out
I/OP1, NC ^{Note}	74	Synchronous Data In (Parity), Synchronous / Asynchronous Data Out (Parity)
I/OP2, NC ^{Note}	24	
/ADV	83	Synchronous Burst Address Advance Input
/AP	84	Synchronous Address Status Processor Input
/AC	85	Synchronous Address Status Controller Input
/CE,CE2, /CE2	98, 97, 92	Synchronous Chip Enable Input
/BW1, /BW2, /BWE	93, 94, 87	Synchronous Byte Write Enable Input
/GW	88	Synchronous Global Write Input
/G	86	Asynchronous Output Enable Input
CLK	89	Clock Input
MODE	31	Asynchronous Burst Sequence Select Input Do not change state during normal operation
ZZ	64	Asynchronous Power Down State Input
V _{DD}	15, 41, 65, 91	Power Supply
V _{SS}	17, 40, 67, 90	Ground
V _{DDQ}	4, 11, 20, 27, 54, 61, 70, 77	Output Buffer Power Supply
V _{SSQ}	5, 10, 21, 26, 55, 60, 71, 76	Output Buffer Ground
NC	1, 2, 3, 6, 7, 14, 16, 25, 28, 29, 30, 38, 39, 42, 51, 52, 53, 56, 57, 66, 75, 78, 79, 95, 96	No Connection

Note NC (No Connection) is used in the μPD4482162GF.

I/OP1 and I/OP2 are used in the μPD4482182GF.

100-pin PLASTIC LQFP (14 x 20)

[μPD4482322GF, μPD4482362GF]

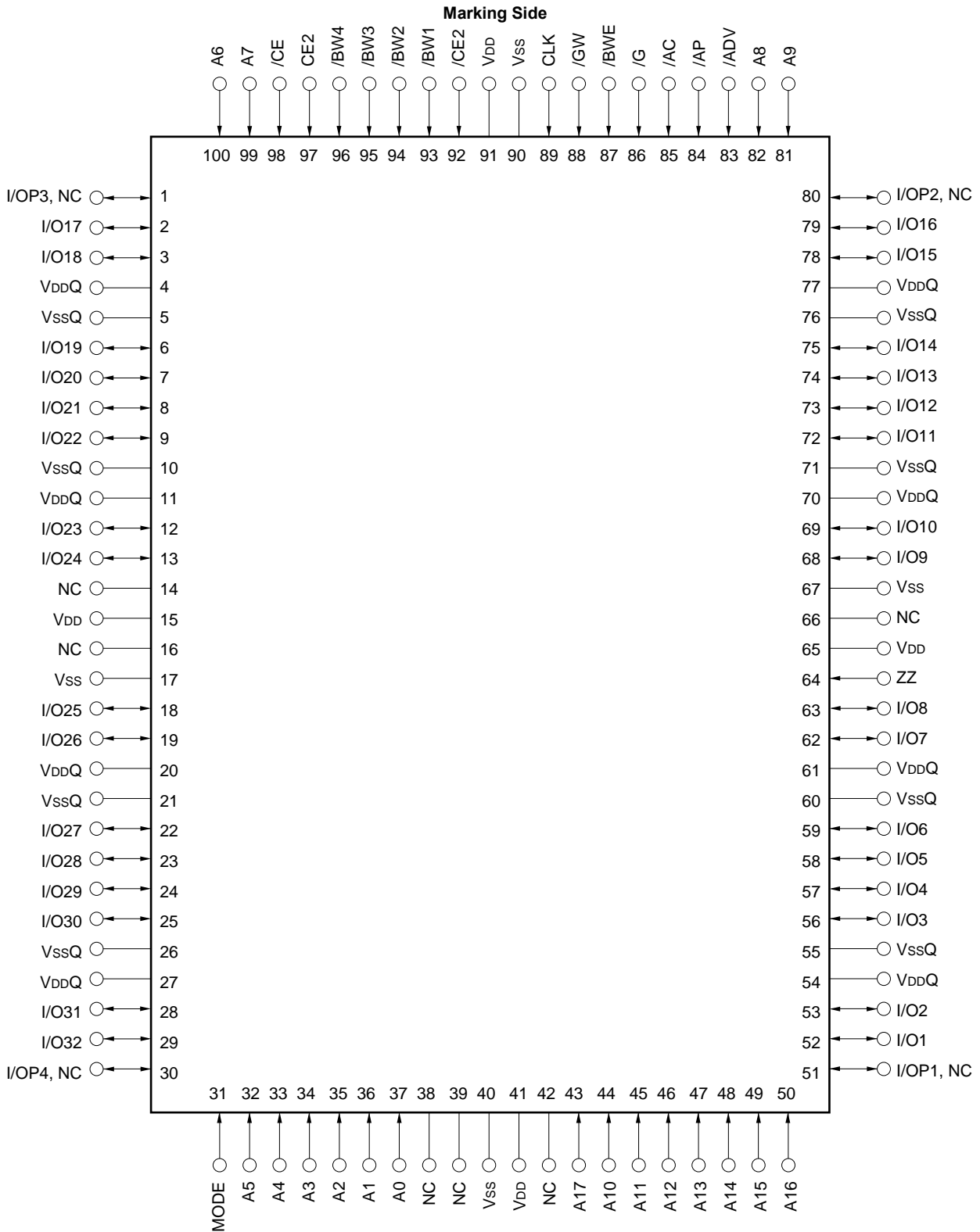

Remark Refer to **Package Drawing** for the 1-pin index mark.

Pin Identification (μPD4482322GF, μPD4482362GF)

Symbol	Pin No.	Description
A0 to A17	37, 36, 35, 34, 33, 32, 100, 99, 82, 81, 44, 45, 46, 47, 48, 49, 50, 43	Synchronous Address Input
I/O1 to I/O32	52, 53, 56, 57, 58, 59, 62, 63, 68, 69, 72, 73, 74, 75, 78, 79, 2, 3, 6, 7, 8, 9, 12, 13, 18, 19, 22, 23, 24, 25, 28, 29	Synchronous Data In, Synchronous / Asynchronous Data Out
I/OP1, NC ^{Note}	51	Synchronous Data In (Parity), Synchronous / Asynchronous Data Out (Parity)
I/OP2, NC ^{Note}	80	
I/OP3, NC ^{Note}	1	
I/OP4, NC ^{Note}	30	
/ADV	83	Synchronous Burst Address Advance Input
/AP	84	Synchronous Address Status Processor Input
/AC	85	Synchronous Address Status Controller Input
/CE, CE2, /CE2	98, 97, 92	Synchronous Chip Enable Input
/BWE1 to /BWE4, /BWE	93, 94, 95, 96, 87	Synchronous Byte Write Enable Input
/GW	88	Synchronous Global Write Input
/G	86	Asynchronous Output Enable Input
CLK	89	Clock Input
MODE	31	Asynchronous Burst Sequence Select Input Do not change state during normal operation
ZZ	64	Asynchronous Power Down State Input
V _{DD}	15, 41, 65, 91	Power Supply
V _{SS}	17, 40, 67, 90	Ground
V _{DDQ}	4, 11, 20, 27, 54, 61, 70, 77	Output Buffer Power Supply
V _{SSQ}	5, 10, 21, 26, 55, 60, 71, 76	Output Buffer Ground
NC	14, 16, 38, 39, 42, 66	No Connection

Note NC (No Connection) is used in the μPD4482322GF.

I/OP1 to I/OP4 are used in the μPD4482362GF.

Block Diagrams

[μPD4482162, μPD4482182]

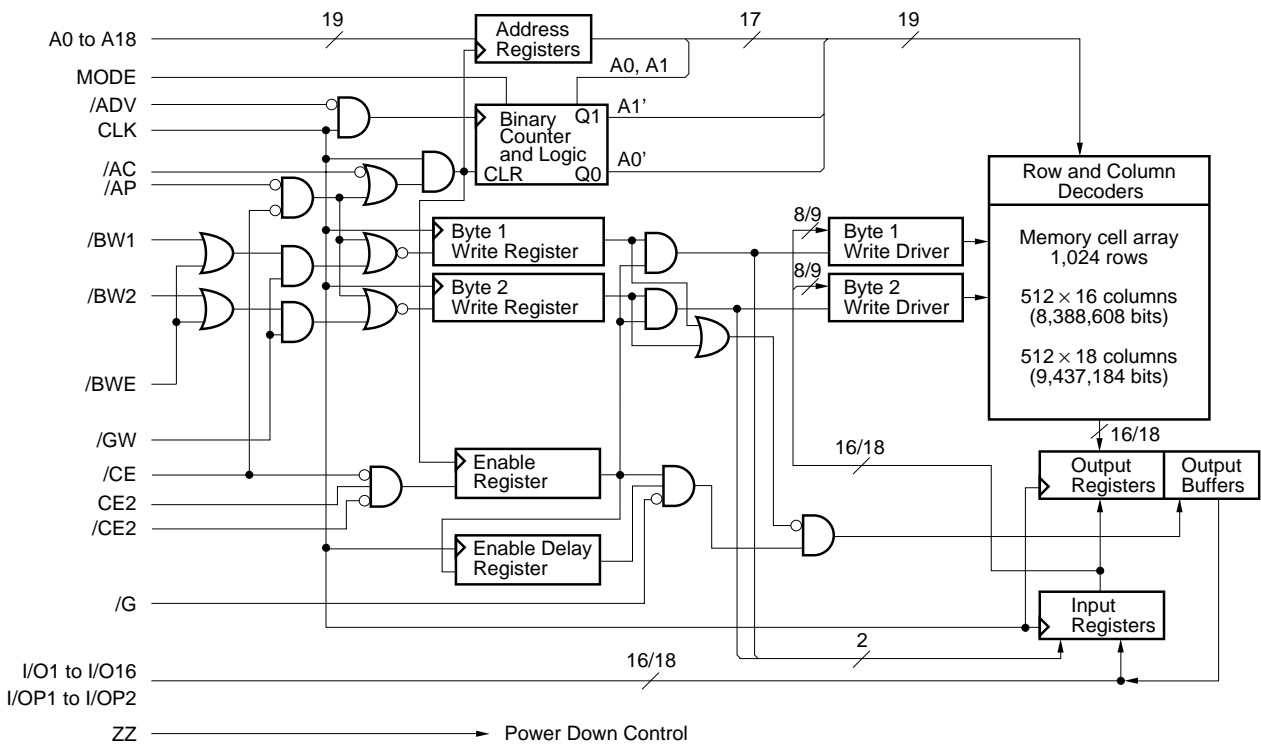

Burst Sequence

[μPD4482162, μPD4482182]

Interleaved Burst Sequence Table (MODE = VDD)

External Address	A18 to A2, A1, A0
1st Burst Address	A18 to A2, A1, /A0
2nd Burst Address	A18 to A2, /A1, A0
3rd Burst Address	A18 to A2, /A1, /A0

Linear Burst Sequence Table (MODE = VSS)

External Address	A18 to A2, 0, 0	A18 to A2, 0, 1	A18 to A2, 1, 0	A18 to A2, 1, 1
1st Burst Address	A18 to A2, 0, 1	A18 to A2, 1, 0	A18 to A2, 1, 1	A18 to A2, 0, 0
2nd Burst Address	A18 to A2, 1, 0	A18 to A2, 1, 1	A18 to A2, 0, 0	A18 to A2, 0, 1
3rd Burst Address	A18 to A2, 1, 1	A18 to A2, 0, 0	A18 to A2, 0, 1	A18 to A2, 1, 0

[μPD4482322, μPD4482362]

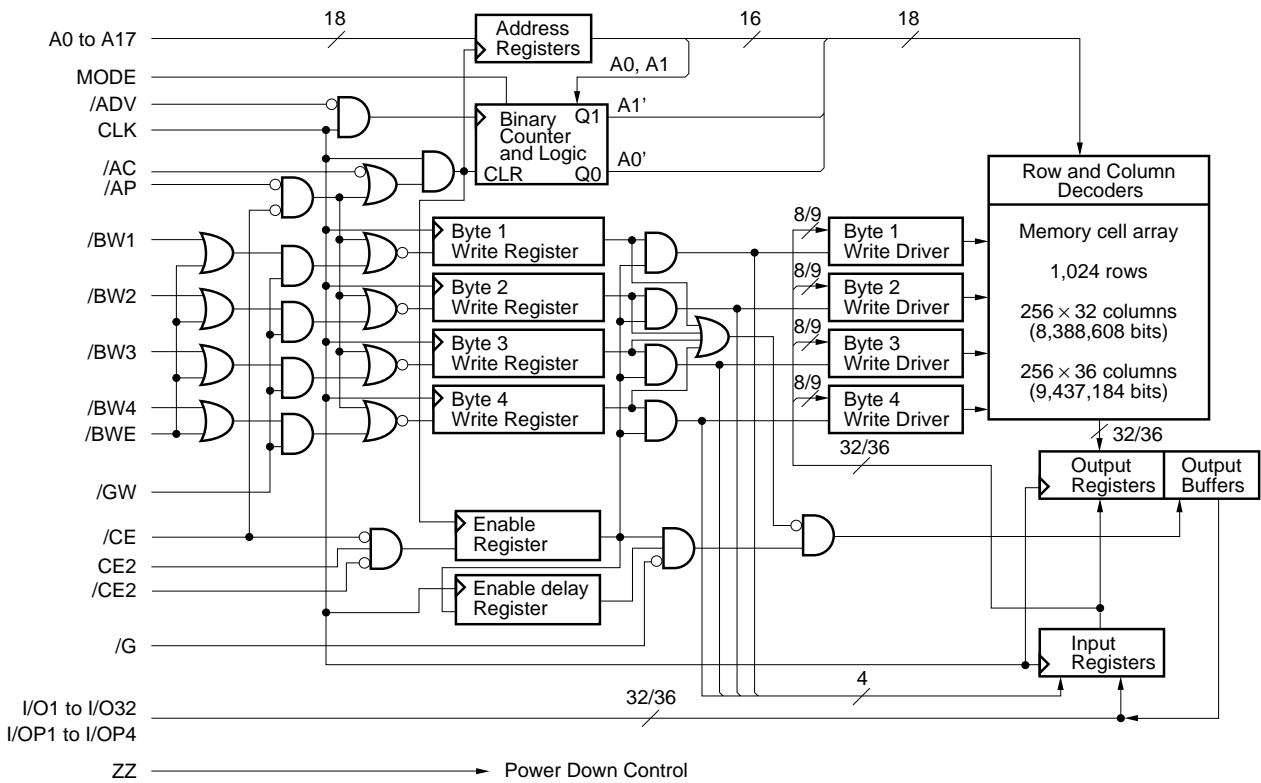

[μPD4482322, μPD4482362]

Interleaved Burst Sequence Table (MODE = VDD)

External Address	A17 to A2, A1, A0
1st Burst Address	A17 to A2, A1, /A0
2nd Burst Address	A17 to A2, /A1, A0
3rd Burst Address	A17 to A2, /A1, /A0

Linear Burst Sequence Table (MODE = Vss)

External Address	A17 to A2, 0, 0	A17 to A2, 0, 1	A17 to A2, 1, 0	A17 to A2, 1, 1
1st Burst Address	A17 to A2, 0, 1	A17 to A2, 1, 0	A17 to A2, 1, 1	A17 to A2, 0, 0
2nd Burst Address	A17 to A2, 1, 0	A17 to A2, 1, 1	A17 to A2, 0, 0	A17 to A2, 0, 1
3rd Burst Address	A17 to A2, 1, 1	A17 to A2, 0, 0	A17 to A2, 0, 1	A17 to A2, 1, 0

Asynchronous Truth Table

Operation	/G	I/O
Read Cycle	L	Dout
Read Cycle	H	High-Z
Write Cycle	×	High-Z, Din
Deselected	×	High-Z

Remark × : don't care

Synchronous Truth Table

Operation	/CE	CE2	/CE2	/AP	/AC	/ADV	/WRITE	CLK	Address
Deselected ^{Note}	H	×	×	×	L	×	×	L → H	None
Deselected ^{Note}	L	L	×	L	×	×	×	L → H	None
Deselected ^{Note}	L	×	H	L	×	×	×	L → H	None
Deselected ^{Note}	L	L	×	H	L	×	×	L → H	None
Deselected ^{Note}	L	×	H	H	L	×	×	L → H	None
Read Cycle / Begin Burst	L	H	L	L	×	×	×	L → H	External
Read Cycle / Begin Burst	L	H	L	H	L	×	H	L → H	External
Read Cycle / Continue Burst	×	×	×	H	H	L	H	L → H	Next
Read Cycle / Continue Burst	H	×	×	×	H	L	H	L → H	Next
Read Cycle / Suspend Burst	×	×	×	H	H	H	H	L → H	Current
Read Cycle / Suspend Burst	H	×	×	×	H	H	H	L → H	Current
Write Cycle / Begin Burst	L	H	L	H	L	×	L	L → H	External
Write Cycle / Continue Burst	×	×	×	H	H	L	L	L → H	Next
Write Cycle / Continue Burst	H	×	×	×	H	L	L	L → H	Next
Write Cycle / Suspend Burst	×	×	×	H	H	H	L	L → H	Current
Write Cycle / Suspend Burst	H	×	×	×	H	H	L	L → H	Current

Note Deselect status is held until new "Begin Burst" entry.

Remarks 1. × : don't care

2. /WRITE = L means any one or more byte write enables (/BW1, /BW2, /BW3 or /BW4) and /BWE are LOW or /GW is LOW.

/WRITE = H means the following two cases.

(1) /BWE and /GW are HIGH.

(2) /BW1, /BW2 and /GW are HIGH, and /BWE is LOW. [μPD4482162, μPD4482182]

/BW1 to /BW4 and /GW are HIGH, and /BWE is LOW. [μPD4482322, μPD4482362]

Partial Truth Table for Write Enables

[μPD4482162, μPD4482182]

Operation	/GW	/BWE	/BW1	/BW2
Read Cycle	H	H	×	×
Read Cycle	H	L	H	H
Write Cycle / Byte 1 (I/O [1:8], I/OP1)	H	L	L	H
Write Cycle / Byte 2 (I/O [9:16], I/OP2)	H	L	H	L
Write Cycle / All Bytes	H	L	L	L
Write Cycle / All Bytes	L	×	×	×

Remark × : don't care

[μPD4482322, μPD4482362]

Operation	/GW	/BWE	/BW1	/BW2	/BW3	/BW4
Read Cycle	H	H	×	×	×	×
Read Cycle	H	L	H	H	H	H
Write Cycle / Byte 1 (I/O [1:8], I/OP1)	H	L	L	H	H	H
Write Cycle / Byte 2 (I/O [9:16], I/OP2)	H	L	H	L	H	H
Write Cycle / Byte 3 (I/O [17:24], I/OP3)	H	L	H	H	L	H
Write Cycle / Byte 4 (I/O [25:32], I/OP4)	H	L	H	H	H	L
Write Cycle / All Bytes	H	L	L	L	L	L
Write Cycle / All Bytes	L	×	×	×	×	×

Remark × : don't care

Pass-Through Truth Table

Previous Cycle				Present Cycle						Next Cycle
Operation	Add	/WRITE	I/O	Operation	Add	/CEs	/WRITE	/G	I/O	Operation
Write Cycle	Ak	L	Dn(Ak)	Read Cycle (Begin Burst)	Am	L	H	L	Q1(Ak)	Read Q1(Am)
				Deselected	-	H	×	×	High-Z	No Carry Over from Previous Cycle

Remarks 1. × : don't care

2. /WRITE = L means any one or more byte write enables (/BW1, /BW2, /BW3 or /BW4) and /BWE are LOW or /GW is LOW.

/WRITE = H means the following two cases.

(1) /BWE and /GW are HIGH.

(2) /BW1, /BW2 and /GW are HIGH, and /BWE is LOW. [μPD4482162, μPD4482182]

/BW1 to /BW4 and /GW are HIGH, and /BWE is LOW. [μPD4482322, μPD4482362]

/CEs = L means /CE is LOW, /CE2 is LOW and CE2 is HIGH.

/CEs = H means /CE is HIGH or /CE2 is HIGH or CE2 is LOW.

ZZ (Sleep) Truth Table

ZZ	Chip Status
≤ 0.2 V	Active
Open	Active
≥ V _{DD} - 0.2 V	Sleep

Electrical Specifications

Absolute Maximum Ratings

Parameter	Symbol	Conditions	MIN.	TYP.	MAX.	Unit	Notes
★ Supply voltage	V _{DD}	-A44, -A50, -A60	-0.5		+4.0	V	
		-A44Y, -A50Y, -A60Y					
		-C60	-0.5		+3.0	V	
		-C60Y					
Output supply voltage	V _{DDQ}		-0.5		V _{DD}	V	
Input voltage	V _{IN}		-0.5		V _{DD} + 0.5	V	1, 2
Input / Output voltage	V _{I/O}		-0.5		V _{DDQ} + 0.5	V	1, 2
★ Operating ambient temperature	T _A	-A44, -A50, -A60, -C60	0		70	°C	
		-A44Y, -A50Y, -A60Y, -C60Y	-40		+85		
Storage temperature	T _{stg}		-55		+125	°C	

- Notes** 1. -2.0 V (MIN.) (Pulse width : 2 ns)
 2. V_{DDQ} + 2.3 V (MAX.) (Pulse width : 2 ns)

Caution Exposing the device to stress above those listed in Absolute Maximum Ratings could cause permanent damage. The device is not meant to be operated under conditions outside the limits described in the operational section of this specification. Exposure to Absolute Maximum Rating conditions for extended periods may affect device reliability.

Recommended DC Operating Conditions

(1/2)

Parameter	Symbol	Conditions	-A44, -A50, -A60 -A44Y, -A50Y, -A60Y			Unit
			MIN.	TYP.	MAX.	
★ Supply voltage	V _{DD}		3.135	3.3	3.465	V
2.5 V LVTTTL Interface						
Output supply voltage	V _{DDQ}		2.375	2.5	2.9	V
High level input voltage	V _{IH}		1.7		V _{DDQ} + 0.3	V
Low level input voltage	V _{IL}		-0.3 ^{Note}		+0.7	V
3.3 V LVTTTL Interface						
Output supply voltage	V _{DDQ}		3.135	3.3	3.465	V
High level input voltage	V _{IH}		2.0		V _{DDQ} + 0.3	V
Low level input voltage	V _{IL}		-0.3 ^{Note}		+0.8	V

Note -0.8 V (MIN.) (Pulse Width : 2 ns)

Recommended DC Operating Conditions

(2/2)

Parameter	Symbol	Conditions	-C60 -C60Y			Unit
			MIN.	TYP.	MAX.	
★ Supply voltage	V _{DD}		2.375	2.5	2.625	V
Output supply voltage	V _{DDQ}		2.375	2.5	2.625	V
High level input voltage	V _{IH}		1.7		V _{DDQ} + 0.3	V
Low level input voltage	V _{IL}		-0.3 ^{Note}		+0.7	V

Note -0.8 V (MIN.) (Pulse Width : 2 ns)

DC Characteristics (Recommended Operating Conditions Unless Otherwise Noted)

Parameter	Symbol	Test condition	MIN.	TYP.	MAX.	Unit	Note	
Input leakage current	I _{LI}	V _{IN} (except ZZ, MODE) = 0 V to V _{DD}	-2		+2	μA		
I/O leakage current	I _{LO}	V _{I/O} = 0 V to V _{DDQ} , Outputs are disabled	-2		+2	μA		
★ Operating supply current	I _{DD}	Device selected, Cycle = MAX. V _{IN} ≤ V _{IL} or V _{IN} ≥ V _{IH} , I _{I/O} = 0 mA	-A44			440	mA	
			-A44Y					
-A50					400			
-A50Y								
			-A60, -C60			320		
			-A60Y, -C60Y					
	I _{DD1}	Suspend cycle, Cycle = MAX. /AC, /AP, /ADV, /GW, /BWEs ≥ V _{IH} , V _{IN} ≤ V _{IL} or V _{IN} ≥ V _{IH} , I _{I/O} = 0 mA				180		
Standby supply current	I _{SB}	Device deselected, Cycle = 0 MHz V _{IN} ≤ V _{IL} or V _{IN} ≥ V _{IH} , All inputs are static				30	mA	
	I _{SB1}	Device deselected, Cycle = 0 MHz V _{IN} ≤ 0.2 V or V _{IN} ≥ V _{DD} - 0.2 V, V _{I/O} ≤ 0.2 V, All inputs are static				15		
	I _{SB2}	Device deselected, Cycle = MAX. V _{IN} ≤ V _{IL} or V _{IN} ≥ V _{IH}				130		
Power down supply current	I _{SBZZ}	ZZ ≥ V _{DD} - 0.2 V, V _{I/O} ≤ V _{DDQ} + 0.2 V				15	mA	
2.5 V LVTTTL Interface								
High level output voltage	V _{OH}	I _{OH} = -2.0 mA	1.7			V		
		I _{OH} = -1.0 mA	2.1					
Low level output voltage	V _{OL}	I _{OL} = +2.0 mA			0.7	V		
		I _{OL} = +1.0 mA			0.4			
3.3 V LVTTTL Interface								
High level output voltage	V _{OH}	I _{OH} = -4.0 mA	2.4			V		
Low level output voltage	V _{OL}	I _{OL} = +8.0 mA			0.4	V		

Capacitance (T_A = 25 °C, f = 1MHz)

Parameter	Symbol	Test conditions	MIN.	TYP.	MAX.	Unit
Input capacitance	C _{IN}	V _{IN} = 0 V			6.0	pF
Input / Output capacitance	C _{I/O}	V _{I/O} = 0 V			8.0	pF
Clock Input capacitance	C _{clk}	V _{clk} = 0 V			6.0	pF

Remark These parameters are periodically sampled and not 100% tested.

AC Characteristics (Recommended Operating Conditions Unless Otherwise Noted)

AC Test Conditions

2.5 V LVTTTL Interface

Input waveform (Rise / Fall time = 1 ns (20 to 80 %))

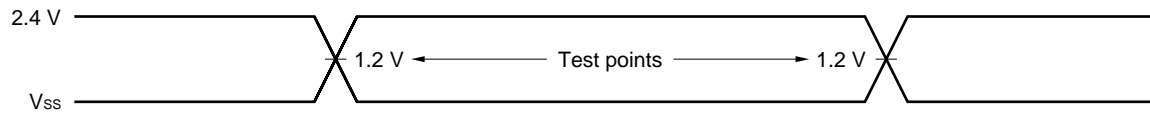

Output waveform

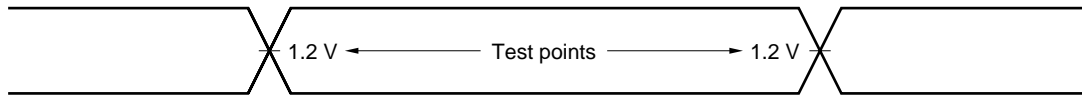

3.3 V LVTTTL Interface

Input waveform (Rise / Fall time = 1 ns (20 to 80%))

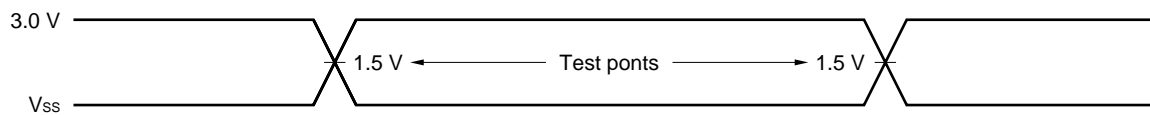

Output waveform

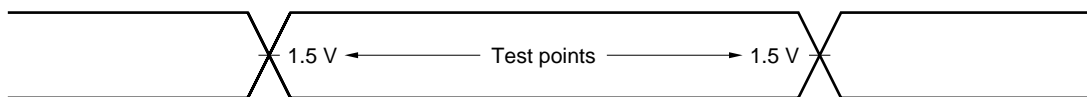

Output load condition

C_L : 30 pF

5 pF (TKHQX1, TKHQX2, TGLQX, TGHQZ, TKHQZ)

External load at test

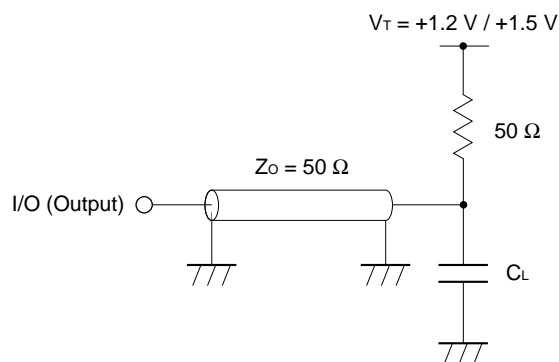

Remark C_L includes capacitance's of the probe and jig, and stray capacitances.

Read and Write Cycle (2.5 V LVTTTL Interface)

★

Parameter	Symbol		-A44, -A50, -A60, -C60 -A44Y, -A50Y, -A60Y, -C60Y (167 MHz)		Unit	Note
	Standard	Alias	MIN.	MAX.		
Cycle time	TKHKH	TCYC	6.0	–	ns	
Clock access time	TKHQV	TCD	–	3.5	ns	
Output enable access time	TGLQV	TOE	–	3.5	ns	
Clock high to output active	TKHQX1	TDC1	0	–	ns	
Clock high to output change	TKHQX2	TDC2	1.5	–	ns	
Output enable to output active	TGLQX	TOLZ	0	–	ns	
Output disable to output High-Z	TGHQZ	TOHZ	0	3.5	ns	
Clock high to output High-Z	TKHQZ	TCZ	1.5	3.5	ns	
Clock high pulse width	TKHKL	TCH	2.0	–	ns	
Clock low pulse width	TKLKH	TCL	2.0	–	ns	
Setup times	Address	TAVKH	TAS	1.5	–	ns
	Address status	TADSVKH	TSS			
	Data in	TDVKH	TDS			
	Write enable	TWVKH	TWS			
	Address advance	TADVVKH	–			
	Chip enable	TEVKH	–			
Hold times	Address	TKHAX	TAH	0.5	–	ns
	Address status	TKHADSX	TSH			
	Data in	TKHDX	TDH			
	Write enable	TKHWX	TWH			
	Address advance	TKHADVX	–			
	Chip enable	TKHEX	–			
Power down entry time	TZZE	TZZE	–	12.0	ns	
Power down recovery time	TZZR	TZZR	–	12.0	ns	

Read and Write Cycle (3.3 V LVTTTL Interface)

★

Parameter	Symbol		-A44 -A44Y (225 MHz)		-A50 -A50Y (200 MHz)		-A60 -A60Y (167 MHz)		Unit	Note
	Standard	Alias	MIN.	MAX.	MIN.	MAX.	MIN.	MAX.		
Cycle time	TKHKH	TCYC	4.4	–	5.0	–	6.0	–	ns	
Clock access time	TKHQV	TCD	–	2.8	–	3.1	–	3.5	ns	
Output enable access time	TGLQV	TOE	–	2.8	–	3.1	–	3.5	ns	
Clock high to output active	TKHQX1	TDC1	0	–	0	–	0	–	ns	
Clock high to output change	TKHQX2	TDC2	1.5	–	1.5	–	1.5	–	ns	
Output enable to output active	TGLQX	TOLZ	0	–	0	–	0	–	ns	
Output disable to output High-Z	TGHQZ	TOHZ	0	2.8	0	3.1	0	3.5	ns	
Clock high to output High-Z	TKHQZ	TCZ	1.5	2.8	1.5	3.1	1.5	3.5	ns	
Clock high pulse width	TKHKL	TCH	1.8	–	2.0	–	2.0	–	ns	
Clock low pulse width	TKLKH	TCL	1.8	–	2.0	–	2.0	–	ns	
Setup times	Address	TAVKH	TAS	1.4	–	1.5	–	1.5	–	ns
	Address status	TADSVKH	TSS							
	Data in	TDVKH	TDS							
	Write enable	TWVKH	TWS							
	Address advance	TADVVKH	–							
	Chip enable	TEVKH	–							
Hold times	Address	TKHAX	TAH	0.4	–	0.5	–	0.5	–	ns
	Address status	TKHADSX	TSH							
	Data in	TKHDX	TDH							
	Write enable	TKHWX	TWH							
	Address advance	TKHADVX	–							
	Chip enable	TKHEX	–							
Power down entry time	TZZE	TZZE	–	8.8	–	10.0	–	12.0	ns	
Power down recovery time	TZZR	TZZR	–	8.8	–	10.0	–	12.0	ns	

READ CYCLE

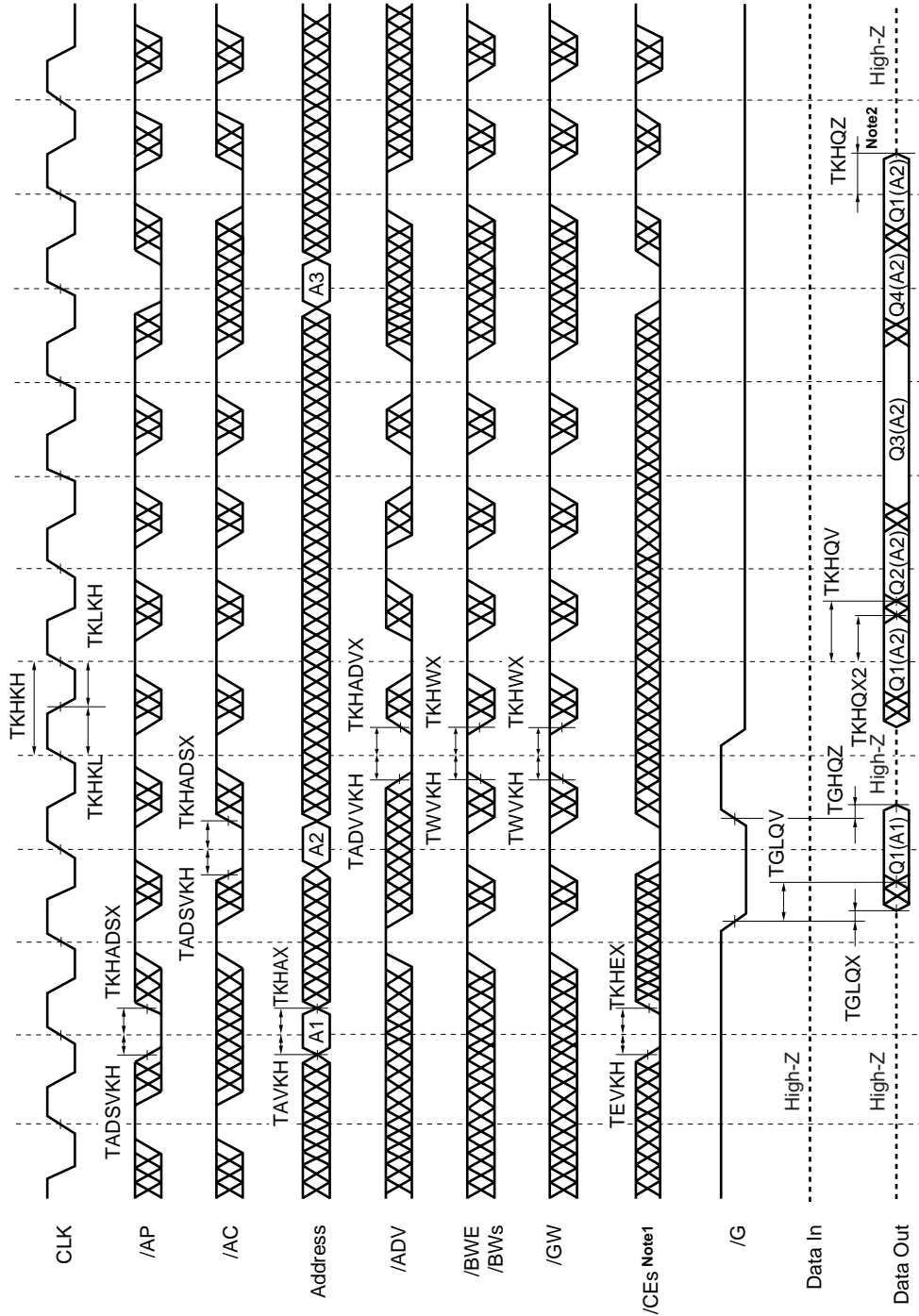

Notes 1. /CEs refers to /CE, CE2 and /CE2. When /CEs is LOW, /CE and /CE2 are LOW and CE2 is HIGH.
 When /CEs is HIGH, /CE and /CE2 are HIGH and CE2 is LOW.

2. Outputs are disabled within one clock cycle after deselect.

Remark Qn(A2) refers to output from address A2. Q1 to Q4 refer to outputs according to burst sequence.

SINGLE READ / WRITE CYCLE

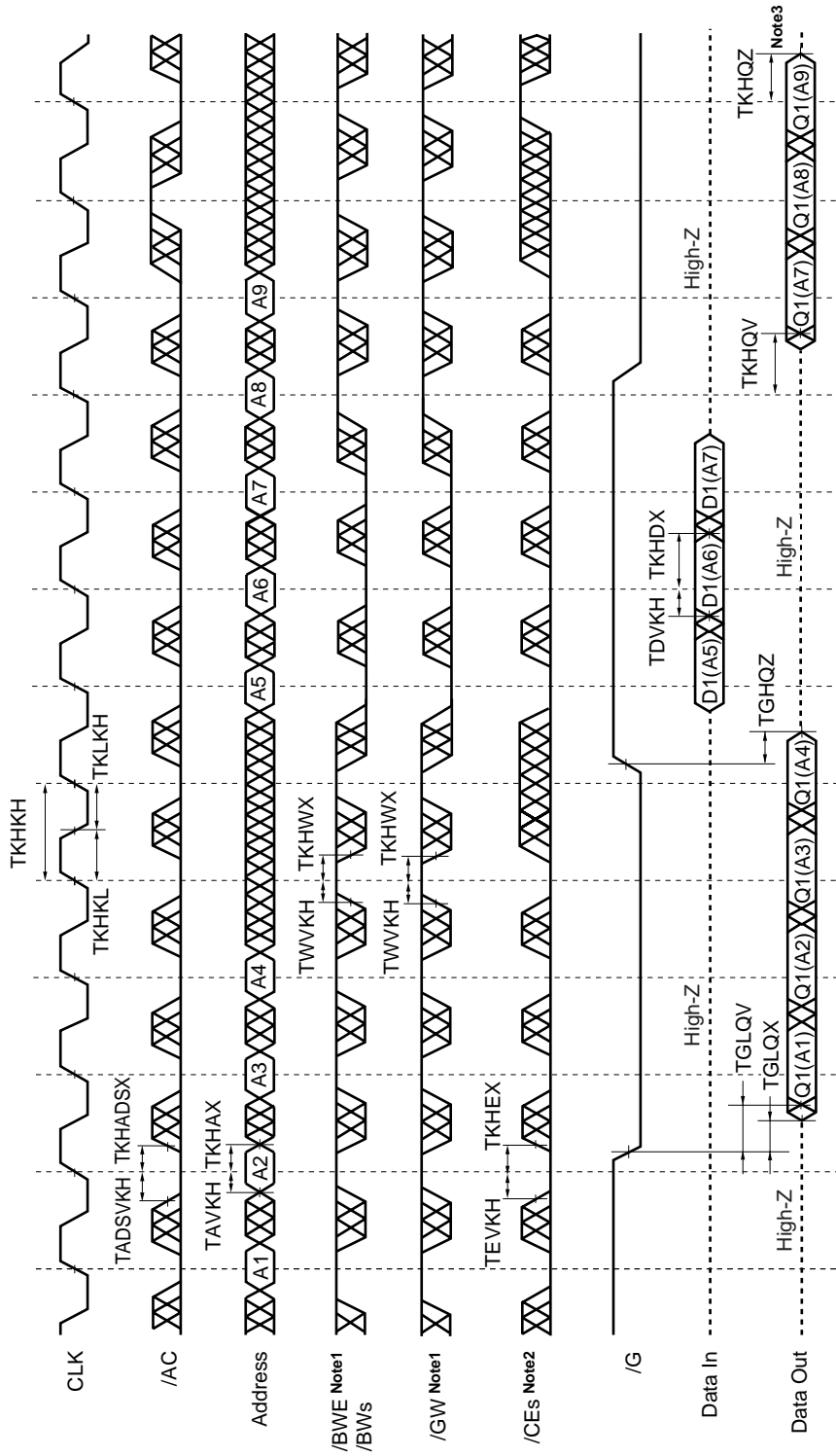

- Notes**
1. All bytes WRITE can be initiated by /GW LOW or /GW HIGH and /BWE, /BW1 to /BW4 LOW.
 2. /CEs refers to /CE, CE2 and /CE2. When /CEs is LOW, /CE and /CE2 are LOW and CE2 is HIGH. When /CEs is HIGH, /CE and /CE2 are HIGH and CE2 is LOW.
 3. Outputs are disabled within one clock cycle after deselect.

Remark /AP is HIGH and /ADV is don't care.

POWER DOWN (ZZ) CYCLE

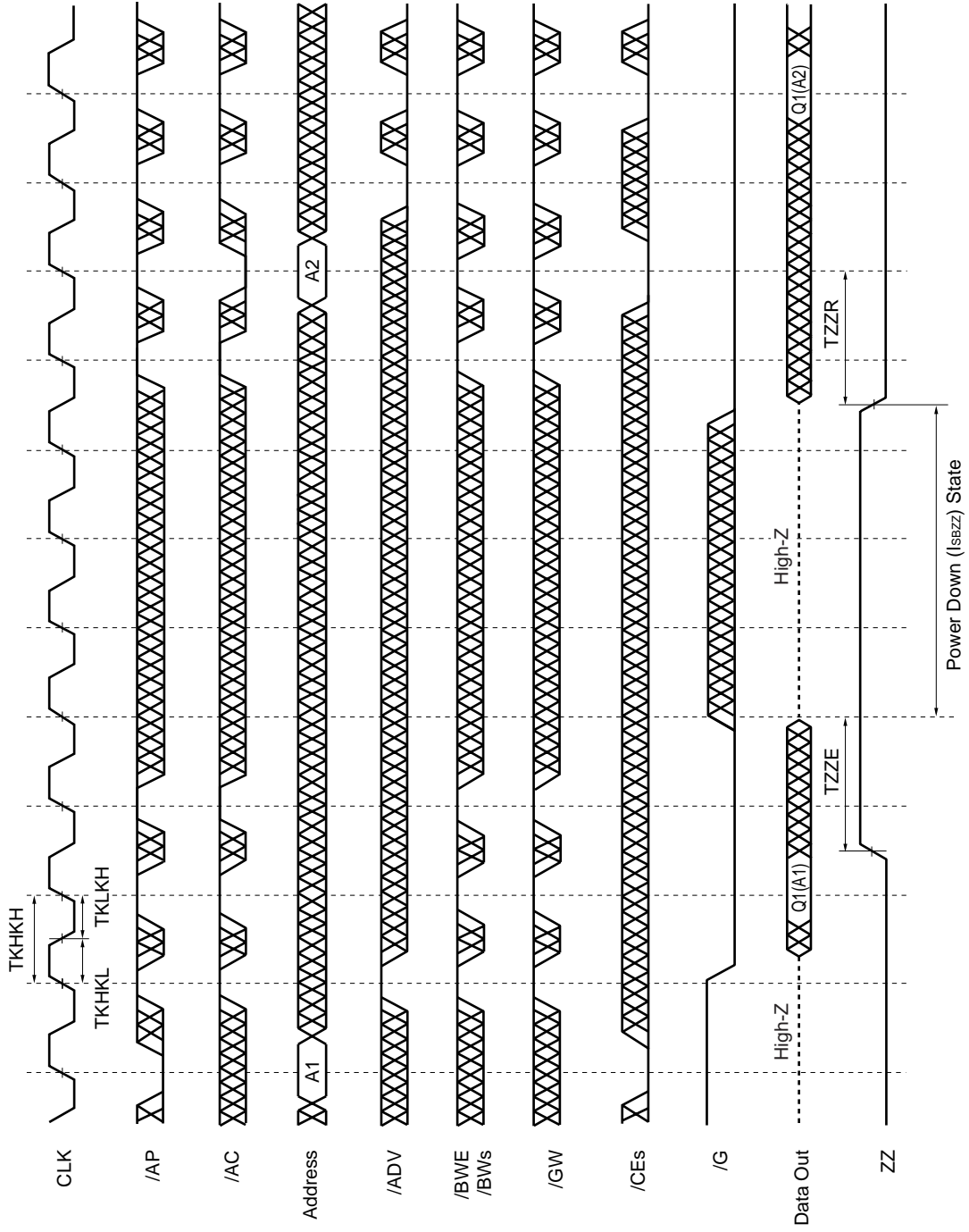

STOP CLOCK CYCLE

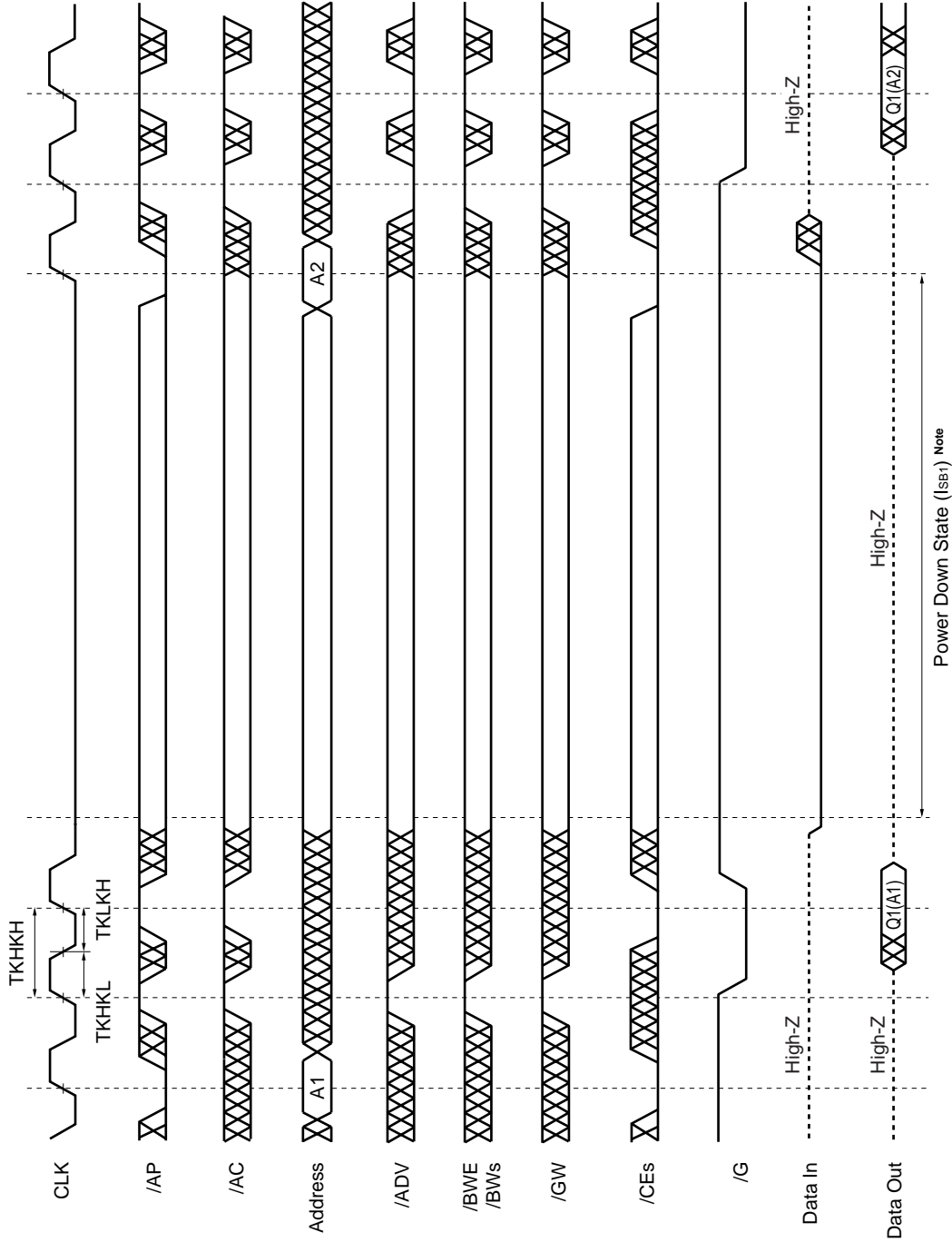

Note $V_{IN} \leq 0.2 V$ or $V_{IN} \geq V_{DD} - 0.2 V$, $V_{IO} \leq 0.2 V$

Package Drawing

100-PIN PLASTIC LQFP (14x20)

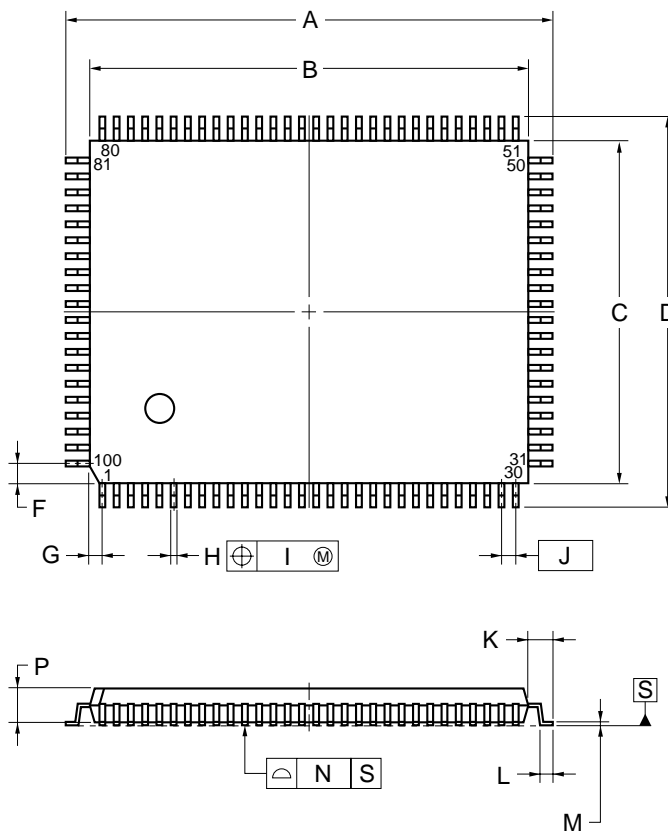

detail of lead end

NOTE

Each lead centerline is located within 0.13 mm of its true position (T.P.) at maximum material condition.

ITEM	MILLIMETERS
A	22.0±0.2
B	20.0±0.2
C	14.0±0.2
D	16.0±0.2
F	0.825
G	0.575
H	0.32 ^{+0.08} _{-0.07}
I	0.13
J	0.65 (T.P.)
K	1.0±0.2
L	0.5±0.2
M	0.17 ^{+0.06} _{-0.05}
N	0.10
P	1.4
Q	0.125±0.075
R	3° ^{+7°} _{-3°}
S	1.7 MAX.

S100GF-65-8ET-1

Recommended Soldering Condition

Please consult with our sales offices for soldering conditions of the μ PD4482162, 4482182, 4482322 and 4482362.

Types of Surface Mount Devices

μ PD4482162GF : 100-pin PLASTIC LQFP (14 x 20)

μ PD4482182GF : 100-pin PLASTIC LQFP (14 x 20)

μ PD4482322GF : 100-pin PLASTIC LQFP (14 x 20)

μ PD4482362GF : 100-pin PLASTIC LQFP (14 x 20)

Revision History

Edition/ Date	Page		Type of revision	Location	Description (Previous edition → This edition)
	This edition	Previous edition			
3rd edition/ Dec. 2002	Throughout	Throughout	Modification Addition	– –	Preliminary Data Sheet → Data Sheet Extended operating temperature products (T _A = –40 to +85 °C)

[MEMO]

[MEMO]

NOTES FOR CMOS DEVICES

① PRECAUTION AGAINST ESD FOR SEMICONDUCTORS

Note:

Strong electric field, when exposed to a MOS device, can cause destruction of the gate oxide and ultimately degrade the device operation. Steps must be taken to stop generation of static electricity as much as possible, and quickly dissipate it once, when it has occurred. Environmental control must be adequate. When it is dry, humidifier should be used. It is recommended to avoid using insulators that easily build static electricity. Semiconductor devices must be stored and transported in an anti-static container, static shielding bag or conductive material. All test and measurement tools including work bench and floor should be grounded. The operator should be grounded using wrist strap. Semiconductor devices must not be touched with bare hands. Similar precautions need to be taken for PW boards with semiconductor devices on it.

② HANDLING OF UNUSED INPUT PINS FOR CMOS

Note:

No connection for CMOS device inputs can be cause of malfunction. If no connection is provided to the input pins, it is possible that an internal input level may be generated due to noise, etc., hence causing malfunction. CMOS devices behave differently than Bipolar or NMOS devices. Input levels of CMOS devices must be fixed high or low by using a pull-up or pull-down circuitry. Each unused pin should be connected to V_{DD} or GND with a resistor, if it is considered to have a possibility of being an output pin. All handling related to the unused pins must be judged device by device and related specifications governing the devices.

③ STATUS BEFORE INITIALIZATION OF MOS DEVICES

Note:

Power-on does not necessarily define initial status of MOS device. Production process of MOS does not define the initial operation status of the device. Immediately after the power source is turned ON, the devices with reset function have not yet been initialized. Hence, power-on does not guarantee out-pin levels, I/O settings or contents of registers. Device is not initialized until the reset signal is received. Reset operation must be executed immediately after power-on for devices having reset function.

- **The information in this document is current as of December, 2002. The information is subject to change without notice. For actual design-in, refer to the latest publications of NEC Electronics data sheets or data books, etc., for the most up-to-date specifications of NEC Electronics products. Not all products and/or types are available in every country. Please check with an NEC Electronics sales representative for availability and additional information.**

- No part of this document may be copied or reproduced in any form or by any means without the prior written consent of NEC Electronics. NEC Electronics assumes no responsibility for any errors that may appear in this document.
- NEC Electronics does not assume any liability for infringement of patents, copyrights or other intellectual property rights of third parties by or arising from the use of NEC Electronics products listed in this document or any other liability arising from the use of such products. No license, express, implied or otherwise, is granted under any patents, copyrights or other intellectual property rights of NEC Electronics or others.
- Descriptions of circuits, software and other related information in this document are provided for illustrative purposes in semiconductor product operation and application examples. The incorporation of these circuits, software and information in the design of a customer's equipment shall be done under the full responsibility of the customer. NEC Electronics assumes no responsibility for any losses incurred by customers or third parties arising from the use of these circuits, software and information.
- While NEC Electronics endeavors to enhance the quality, reliability and safety of NEC Electronics products, customers agree and acknowledge that the possibility of defects thereof cannot be eliminated entirely. To minimize risks of damage to property or injury (including death) to persons arising from defects in NEC Electronics products, customers must incorporate sufficient safety measures in their design, such as redundancy, fire-containment and anti-failure features.
- NEC Electronics products are classified into the following three quality grades: "Standard", "Special" and "Specific".

The "Specific" quality grade applies only to NEC Electronics products developed based on a customer-designated "quality assurance program" for a specific application. The recommended applications of an NEC Electronics product depend on its quality grade, as indicated below. Customers must check the quality grade of each NEC Electronics product before using it in a particular application.

"Standard": Computers, office equipment, communications equipment, test and measurement equipment, audio and visual equipment, home electronic appliances, machine tools, personal electronic equipment and industrial robots.

"Special": Transportation equipment (automobiles, trains, ships, etc.), traffic control systems, anti-disaster systems, anti-crime systems, safety equipment and medical equipment (not specifically designed for life support).

"Specific": Aircraft, aerospace equipment, submersible repeaters, nuclear reactor control systems, life support systems and medical equipment for life support, etc.

The quality grade of NEC Electronics products is "Standard" unless otherwise expressly specified in NEC Electronics data sheets or data books, etc. If customers wish to use NEC Electronics products in applications not intended by NEC Electronics, they must contact an NEC Electronics sales representative in advance to determine NEC Electronics' willingness to support a given application.

(Note)

- (1) "NEC Electronics" as used in this statement means NEC Electronics Corporation and also includes its majority-owned subsidiaries.
- (2) "NEC Electronics products" means any product developed or manufactured by or for NEC Electronics (as defined above).