



F1058

General Description

Silicon VDMOS and LDMOS transistors designed specifically for broadband RF applications. Suitable for Military Radios, Cellular and Paging Amplifier Base Stations, Broadcast FM/AM, MRI, Laser Driver and others.

"Polyfet"TM process features gold metal for greatly extended lifetime. Low output capacitance and high F_t enhance broadband performance

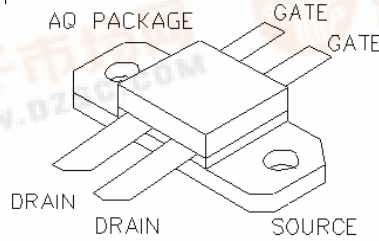

PATENTED GOLD METALIZED SILICON GATE ENHANCEMENT MODE RF POWER VDMOS TRANSISTOR

30 Watts Push - Pull

Package Style AQ

HIGH EFFICIENCY, LINEAR, HIGH GAIN, LOW NOISE

ABSOLUTE MAXIMUM RATINGS (TC = 25 °C)

Total Device Dissipation	Junction to Case Thermal Resistance	Maximum Junction Temperature	Storage Temperature	DC Drain Current	Drain to Gate Voltage	Drain to Source Voltage	Gate to Source Voltage
100 Watts	1.75 °C/W	200 °C	-65 °C to 150 °C	4 A	70 V	70V	30V

RF CHARACTERISTICS (30WATTS OUTPUT)

SYMBOL	PARAMETER	MIN	TYP	MAX	UNITS	TEST CONDITIONS
Gps	Common Source Power Gain	13			dB	$I_{dq} = 0.4 A, V_{ds} = 28.0V, F = 400 MHz$
η	Drain Efficiency		60		%	$I_{dq} = 0.4 A, V_{ds} = 28.0V, F = 400 MHz$
VSWR	Load Mismatch Toleranc			20:1	Relative	$I_{dq} = 0.4 A, V_{ds} = 28.0V, F = 400 MHz$

ELECTRICAL CHARACTERISTICS (EACH SIDE)

SYMBOL	PARAMETER	MIN	TYP	MAX	UNITS	TEST CONDITIONS
Bvdss	Drain Breakdown Voltag	65			V	$I_{ds} = 0.05 A, V_{gs} = 0V$
Idss	Zero Bias Drain Curren			1	mA	$V_{ds} = 28.0 V, V_{gs} = 0V$
Igss	Gate Leakage Curren			1	uA	$V_{ds} = 0 V, V_{gs} = 30V$
Vgs	Gate Bias for Drain Curren	1		7	V	$I_{ds} = 0.1 A, V_{gs} = V_{ds}$
gM	Forward Transconductanc		0.8		Mho	$V_{ds} = 10V, V_{gs} = 5V$
Rdson	Saturation Resistanc		1		Ohm	$V_{gs} = 20V, I_{ds} = 4A$
Idsat	Saturation Curren		5.5		Amp	$V_{gs} = 20V, V_{ds} = 10V$
Ciss	Common Source Input Capacitanc		33		pF	$V_{ds} = 28.0 V, V_{gs} = 0V, F = 1 MHz$
Crss	Common Source Feedback Capacitanc		4		pF	$V_{ds} = 28.0 V, V_{gs} = 0V, F = 1 MHz$
Coss	Common Source Output Capacitanc		20		pF	$V_{ds} = 28.0 V, V_{gs} = 0V, F = 1 MHz$



F1058

POUT VS PIN GRAPH

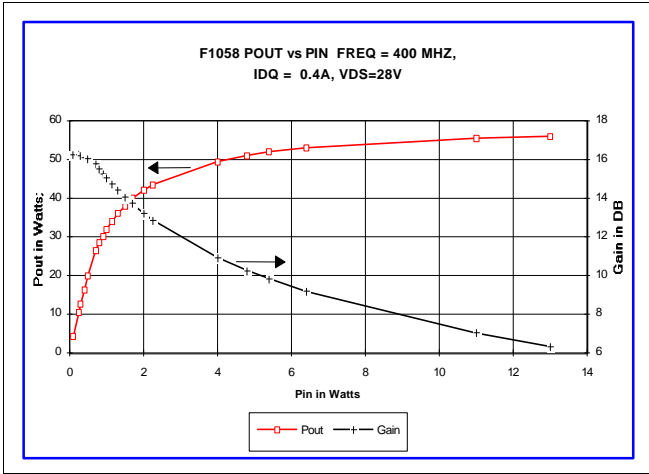

IV CURVE

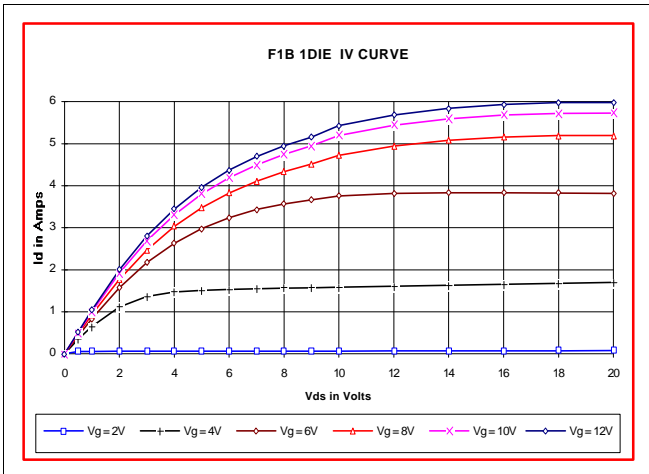

CAPACITANCE VS VOLTAGE

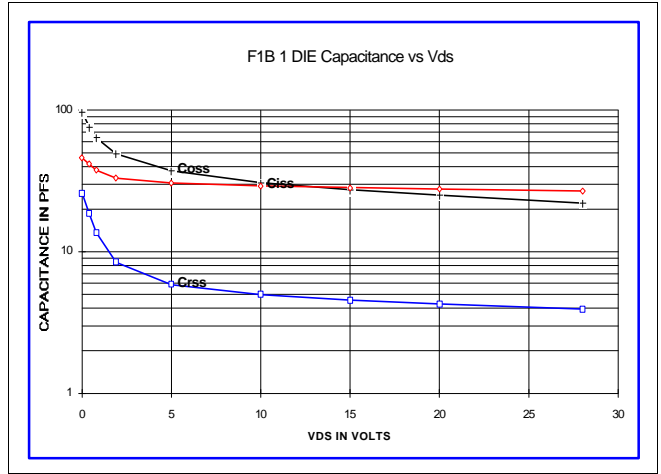

ID AND GM VS VGS

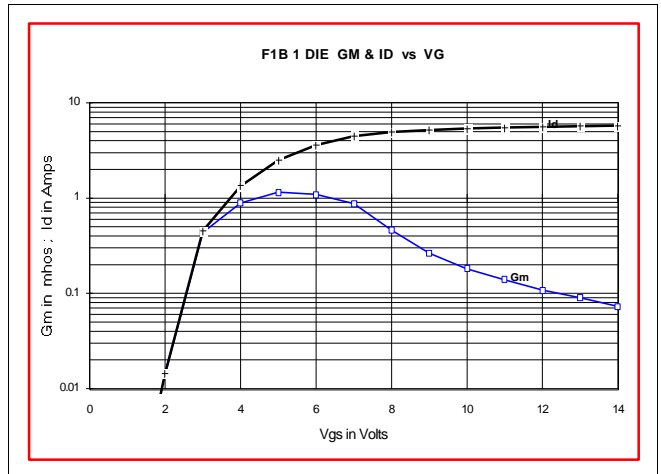

S11 AND S22 SMITH CHART

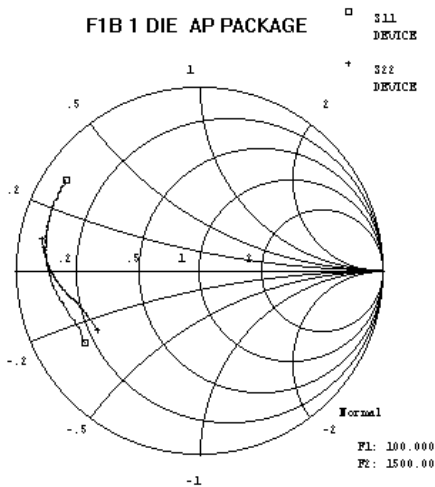

PACKAGE DIMENSIONS IN INCHES

