



# MRF237

## SILICON NPN RF POWER TRANSISTOR

**DESCRIPTION:** The MRF237 is designed for large signal power amplifier applications operating to 225 MHz

### MAXIMUM RATINGS

$I_C$	1.0 A
$V_{CBO}$	36 V
$V_{CEO}$	18 V
$P_{DISS}$	8.0 W @ $T_C = 25^\circ C$
$T_J$	-65 °C to +200 °C
$T_{STG}$	-65 °C to +200 °C
$\theta_{JC}$	22 °C/W

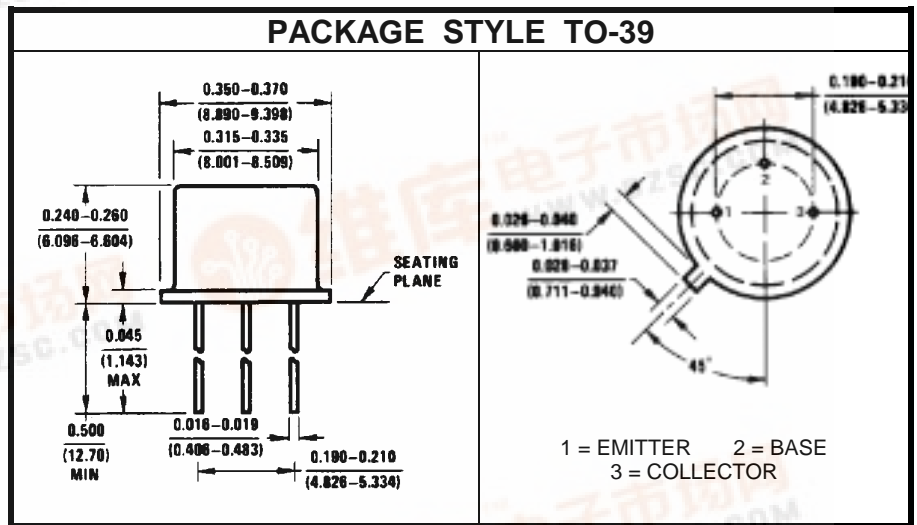

### CHARACTERISTICS $T_C = 25^\circ C$

SYMBOL	TEST CONDITIONS	MINIMUM	TYPICAL	MAXIMUM	UNITS
$BV_{CEO}$	$I_C = 10\text{ mA}$	18			V
$BV_{CES}$	$I_C = 5.0\text{ mA}$	36			V
$BV_{EBO}$	$I_C = 1.0\text{ mA}$	4.0			V
$I_{CBO}$	$V_{CE} = 15\text{ V}$			.25	mA
$h_{FE}$	$V_{CE} = 5.0\text{ V}$ $I_C = 250\text{ mA}$	5.0			---
$C_{OB}$	$V_{CB} = 15\text{ V}$ $f = 1.0\text{ MHz}$		15	20	pF
$G_{PE}$	$V_{CC} = 12.5\text{ V}$ $P_{OUT} = 4.0\text{ W}$ $f = 175\text{ MHz}$	12	14		dB
$\eta$		50	62		%

[www.DataSheet.in](http://www.DataSheet.in)

