



**RF2361**

3V LOW NOISE AMPLIFIER/  
3V PA DRIVER AMPLIFIER

Typical Applications

- TDMA/CDMA/FM Cellular PCS LNA
- Low Noise Transmit Driver Amplifier
- General Purpose Amplification
- Commercial and Consumer Systems

Product Description

The RF2361 is a low noise amplifier with a very high dynamic range designed for digital cellular applications. The device functions as an outstanding front end low noise amplifier or power amplifier driver amplifier in the transmit chain of digital subscriber units where low transmit noise power is a concern. When used as an LNA, the bias current can be set externally. When used as a PA driver, the IC can operate directly from a single cell Li-ion battery and includes a power down feature that can be used to completely turn off the device. The IC is featured in a standard SOT 5-lead plastic package.

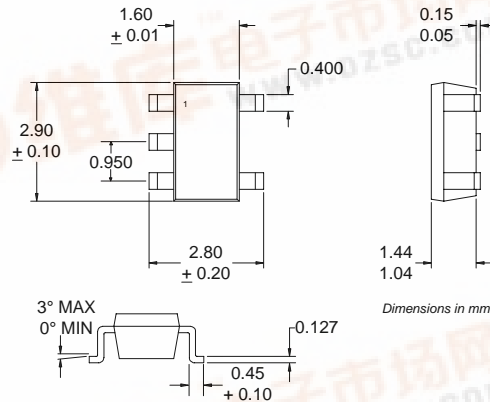

4  
GENERAL PURPOSE  
AMPLIFIERS

Optimum Technology Matching® Applied

- Si BJT       GaAs HBT       GaAs MESFET  
 Si Bi-CMOS       SiGe HBT       Si CMOS

Package Style: SOT 5-Lead

Features

- Low Noise and High Intercept Point
- Adjustable Bias Current
- Power Down Control
- Single 2.5V to 6.0V Power Supply
- 150MHz to 2500MHz Operation
- Extremely Small SOT 5-Lead Package

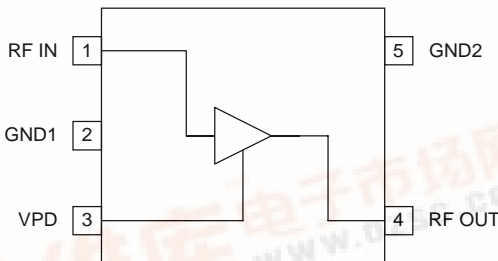

Functional Block Diagram

Ordering Information

- RF2361      3V Low Noise Amplifier/ 3V PA Driver Amplifier  
 RF2361 PCBA-D      Fully Assembled Evaluation Board (Driver)  
 RF2361 PCBA-L      Fully Assembled Evaluation Board (LNA)

RF Micro Devices, Inc.  
7625 Thorndike Road  
Greensboro, NC 27409, USA

Tel (336) 664 1233  
Fax (336) 664 0454  
<http://www.rfmd.com>



# RF2361

## Absolute Maximum Ratings

Parameter	Rating	Unit
Supply Voltage, $V_{CC}$	-0.5 to +8.0	$V_{DC}$
Power Down Voltage, $V_{PD}$	$\leq V_{CC}$	$V_{DC}$
Input RF Level	+10	dBm
Operating Ambient Temperature	-40 to +85	$^{\circ}C$
Storage Temperature	-40 to +150	$^{\circ}C$



Caution! ESD sensitive device.

RF Micro Devices believes the furnished information is correct and accurate at the time of this printing. However, RF Micro Devices reserves the right to make changes to its products without notice. RF Micro Devices does not assume responsibility for the use of the described product(s).

Parameter	Specification			Unit	Condition
	Min.	Typ.	Max.		
<b>Overall</b> RF Frequency Range		150 to 2500		MHz	
<b>Low Noise Amplifier</b> <b>881 MHz Performance</b>					Schematic per LNA Application; $T=25^{\circ}C$ , $RF=881MHz$ , $V_{PD}=2.8V$ , $R1=1k\Omega$
Gain	19.5	20		dB	$V_{CC}=3.0V$ , $I_{CC}=7.6mA$
	19.5	20		dB	$V_{CC}=2.7V$ , $I_{CC}=7.5mA$
Noise Figure		1.4	1.6	dB	$V_{CC}=3.0V$ , $I_{CC}=7.6mA$
		1.4	1.6	dB	$V_{CC}=2.7V$ , $I_{CC}=7.5mA$
Input IP3		+6.0		dBm	$V_{CC}=3.0V$ , $I_{CC}=7.6mA$
		+5.5		dBm	$V_{CC}=2.7V$ , $I_{CC}=7.5mA$
<b>Low Noise Amplifier</b> <b>1950 MHz Performance</b>					Schematic per LNA Application; $T=25^{\circ}C$ , $RF=1950MHz$ , $V_{PD}=2.8V$ , $R1=1k\Omega$
Gain	12.5	13		dB	$V_{CC}=3.0V$ , $I_{CC}=6.4mA$
	12.5	13		dB	$V_{CC}=2.7V$ , $I_{CC}=6.3mA$
Noise Figure		1.3	1.5	dB	$V_{CC}=3.0V$ , $I_{CC}=6.4mA$
		1.3	1.5	dB	$V_{CC}=2.7V$ , $I_{CC}=6.3mA$
Input IP3		+16.5		dBm	$V_{CC}=3.0V$ , $I_{CC}=6.4mA$
		+16.0		dBm	$V_{CC}=2.7V$ , $I_{CC}=6.3mA$
<b>Driver Amplifier</b> <b>836 MHz Performance</b>					Schematic per Driver Amplifier Application; $T=25^{\circ}C$ , $RF=836MHz$ , $V_{PD}=2.8V$
Gain	19.5	20.5	21.5	dB	$V_{CC}=3.5V$
	19.5	20.5	21.5	dB	$V_{CC}=3.0V$
	19.5	20.5	21.5	dB	$V_{CC}=2.7V$
Output IP3	25	+32.0	35	dBm	$V_{CC}=3.5V$
		+29.0		dBm	$V_{CC}=3.0V$
		+27.8		dBm	$V_{CC}=2.7V$
Noise Figure		1.9	2.0	dB	$V_{CC}=3.5V$
		1.85	2.0	dB	$V_{CC}=3.0V$
		1.8	2.0	dB	$V_{CC}=2.7V$
Reverse Isolation		25		dB	$V_{CC}=3.5V$
		25		dB	$V_{CC}=3.0V$
		25		dB	$V_{CC}=2.7V$
Input VSWR		1.8:1	2.0:1		
Output VSWR		1.25:1	2.0:1		
$P_{1dB}$	13	14.4		dBm	$V_{CC}=3.5V$
	12	12.5		dBm	$V_{CC}=3.0V$
	10.5	11.5		dBm	$V_{CC}=2.7V$

Parameter	Specification			Unit	Condition
	Min.	Typ.	Max.		
<b>Power Supply</b>					T = 25 °C
Voltage (V <sub>CC</sub> )		2.5 to 6.0		V	
Voltage (V <sub>PD</sub> )	2.7	2.8	2.9	V	
Current Consumption - Driver Amplifier	12.5	21.5	27	mA	V <sub>CC</sub> =3.5V; V <sub>PD</sub> =2.8V; V <sub>PD</sub> +V <sub>CC</sub> - Current Consumption from V <sub>PD</sub> is 2.0mA Typ. @ V <sub>PD</sub> =2.8V and 3.0mA Max @ V <sub>PD</sub> =2.9V
	18	20	22	mA	V <sub>CC</sub> =3.5V; V <sub>PD</sub> =2.7V; V <sub>PD</sub> + V <sub>CC</sub>
	19	23	29	mA	V <sub>CC</sub> =3.5V; V <sub>PD</sub> =2.9V; V <sub>PD</sub> + V <sub>CC</sub>
Power Down			10	μA	V <sub>CC</sub> =3.5V; V <sub>PD</sub> ≤ 0.9V
<b>Driver Amplifier 1880MHz Performance</b>					Schematic per Driver Amplifier Application; T=25°C, RF=1880MHz, V <sub>PD</sub> =2.8V
Gain	13.0	14.0	14.5	dB	V <sub>CC</sub> =3.5V
	13.0	14.0	14.5	dB	V <sub>CC</sub> =3.0V
	13.0	14.0	14.5	dB	V <sub>CC</sub> =2.7V
Output IP3	27	+35.0	38	dBm	V <sub>CC</sub> =3.5V
		+31.0		dBm	V <sub>CC</sub> =3.0V
		+28.8		dBm	V <sub>CC</sub> =2.7V
Noise Figure		1.85	2.0	dB	V <sub>CC</sub> =3.5V
		1.8	2.0	dB	V <sub>CC</sub> =3.0V
		1.75	2.0	dB	V <sub>CC</sub> =2.7V
Reverse Isolation		19		dB	V <sub>CC</sub> =3.5V
		19		dB	V <sub>CC</sub> =3.0V
		19		dB	V <sub>CC</sub> =2.7V
Input VSWR		1.6:1	2.0:1		
Output VSWR		1.6:1	2.0:1		Using External LC network used on evaluation board.
P <sub>1dB</sub>	14	15.6		dBm	V <sub>CC</sub> =3.5V
	13	14.1		dBm	V <sub>CC</sub> =3.0V
	12	13.1		dBm	V <sub>CC</sub> =2.7V
<b>Power Supply</b>					T = 25 °C
Voltage (V <sub>CC</sub> )		2.5 to 6.0		V	
Voltage (V <sub>PD</sub> )	2.7	2.8	2.9	V	
Current Consumption - Driver Amplifier	11.5	19.5	25.5	mA	V <sub>CC</sub> =3.5V; V <sub>PD</sub> =2.8V; V <sub>PD</sub> +V <sub>CC</sub> - Current Consumption from V <sub>PD</sub> is 2.0mA Typ. @ V <sub>PD</sub> =2.8V and 3.0mA Max @ V <sub>PD</sub> =2.9V
	16	18	20	mA	V <sub>CC</sub> =3.5V; V <sub>PD</sub> =2.7V; V <sub>PD</sub> + V <sub>CC</sub>
	18	20.5	27	mA	V <sub>CC</sub> =3.5V; V <sub>PD</sub> =2.9V; V <sub>PD</sub> + V <sub>CC</sub>
Power Down			10	μA	V <sub>CC</sub> =3.5V; V <sub>PD</sub> ≤ 0.9V

# RF2361

Pin	Function	Description	Interface Schematic
1	RF IN	RF input pin. This pin is DC coupled and matched to 50Ω at 836 MHz.	
2	GND1	Ground connection. Keep traces physically short and connect immediately to ground plane for best performance.	
3	VPD	<p>For low noise amplifier applications, this pin is used to control the bias current. See plots for bias current settings. An external resistor (R1) can be used to set the bias current for any <math>V_{PD}</math> voltage.</p> <p>For driver amplifier applications, this is the Power Down pin for the IC. <math>V_{PD}=2.8V \pm 0.1V</math> is required for proper operation. <math>V_{PD}&lt;0.9V</math> turns off the Part. External RF bypassing is required. The trace length between the pin and the bypass capacitors should be minimized. The ground side of the bypass capacitors should connect immediately to ground plane. Nominal current required for <math>V_{PD}=2.8V</math> is 2.0mA typical and 3.0mA Max (@ <math>V_{PD}=2.9V</math>).</p>	
4	RF OUT	Amplifier Output pin. This pin is an open-collector output. It must be biased to either $V_{CC}$ or pin 4 through a choke or matching inductor. This pin is typically matched to 50Ω with a shunt bias/matching inductor and series blocking/matching capacitor. Refer to application schematics.	
5	GND2	Ground connection. Keep traces physically short and connect immediately to ground plane for best performance.	

**Application Schematic:  
Low Noise Amplifier ~881 MHz Operation**

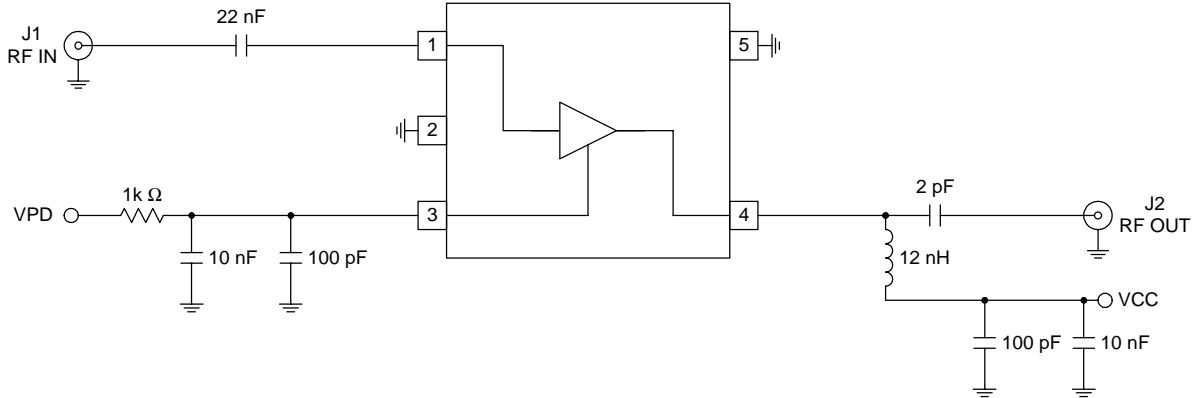

**Application Schematic:  
Low Noise Amplifier ~1950 MHz Operation**

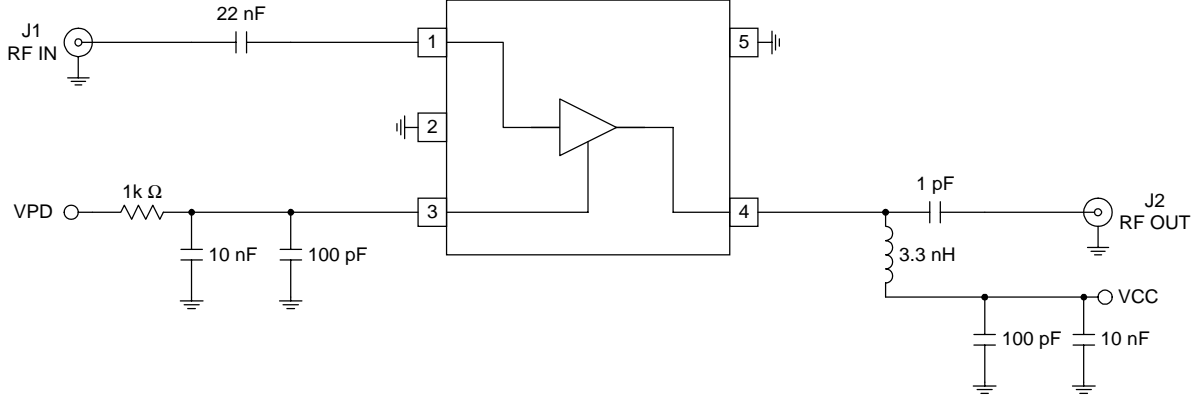

# RF2361

## Application Schematic: Driver Amplifier ~836MHz Operation

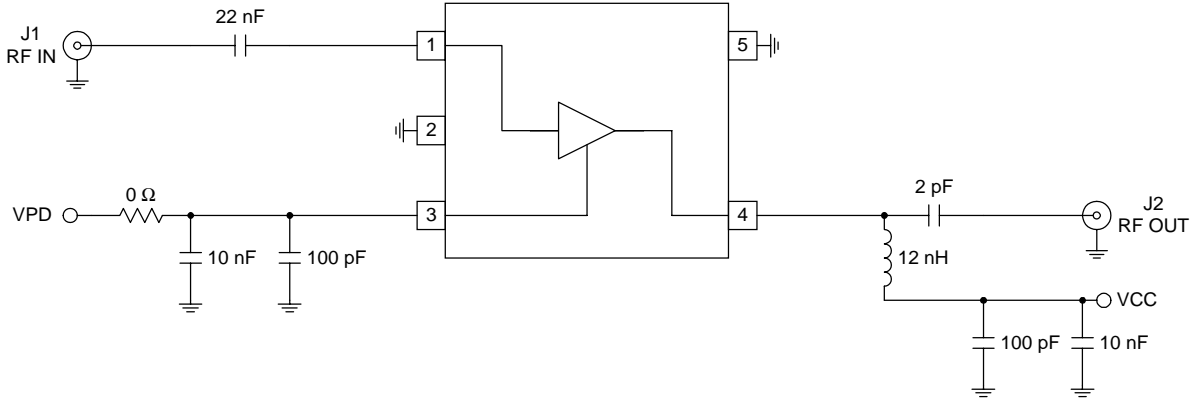

## Application Schematic: Driver Amplifier ~1880MHz Operation

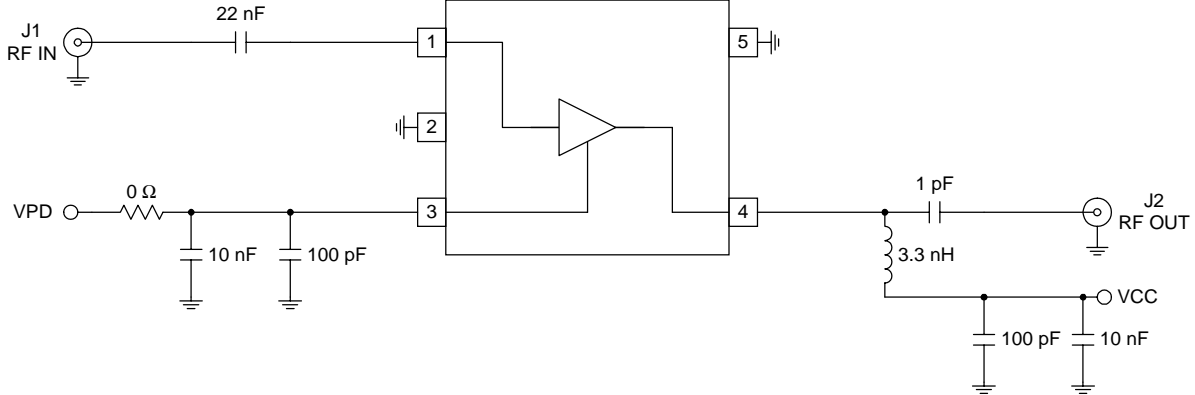

4

GENERAL PURPOSE  
AMPLIFIERS

## Evaluation Board Schematic: Low Noise Amplifier ~881MHz Operation (Download [Bill of Materials](http://www.rfmd.com) from www.rfmd.com.)

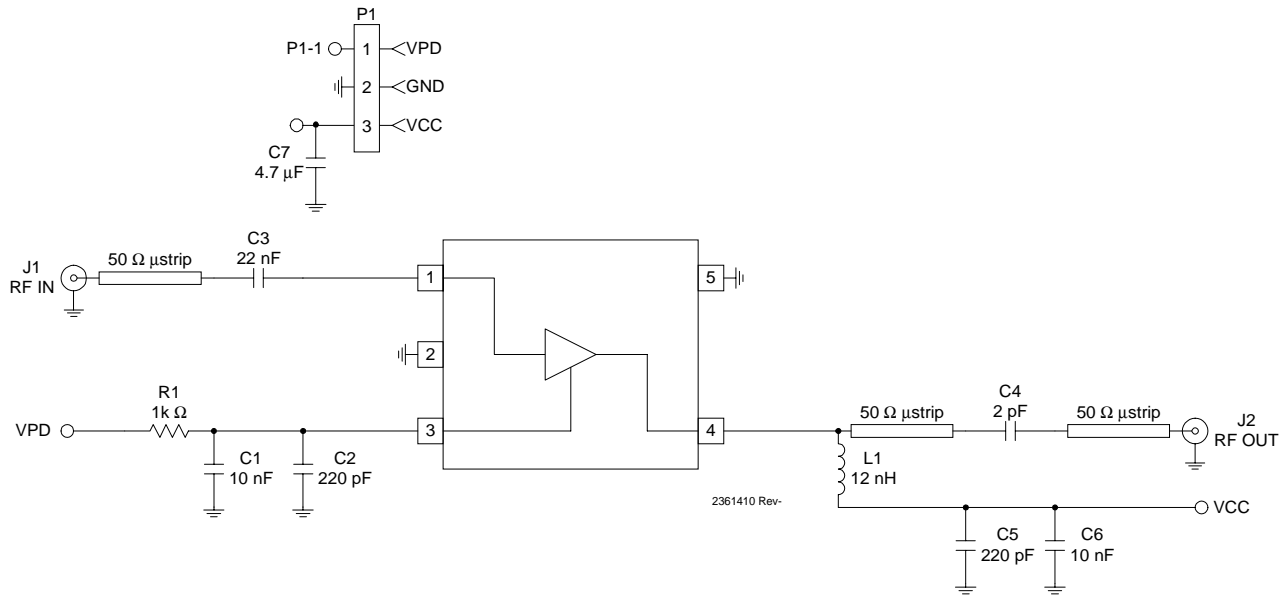

## Evaluation Board Schematic: Driver Amplifier ~836MHz Operation

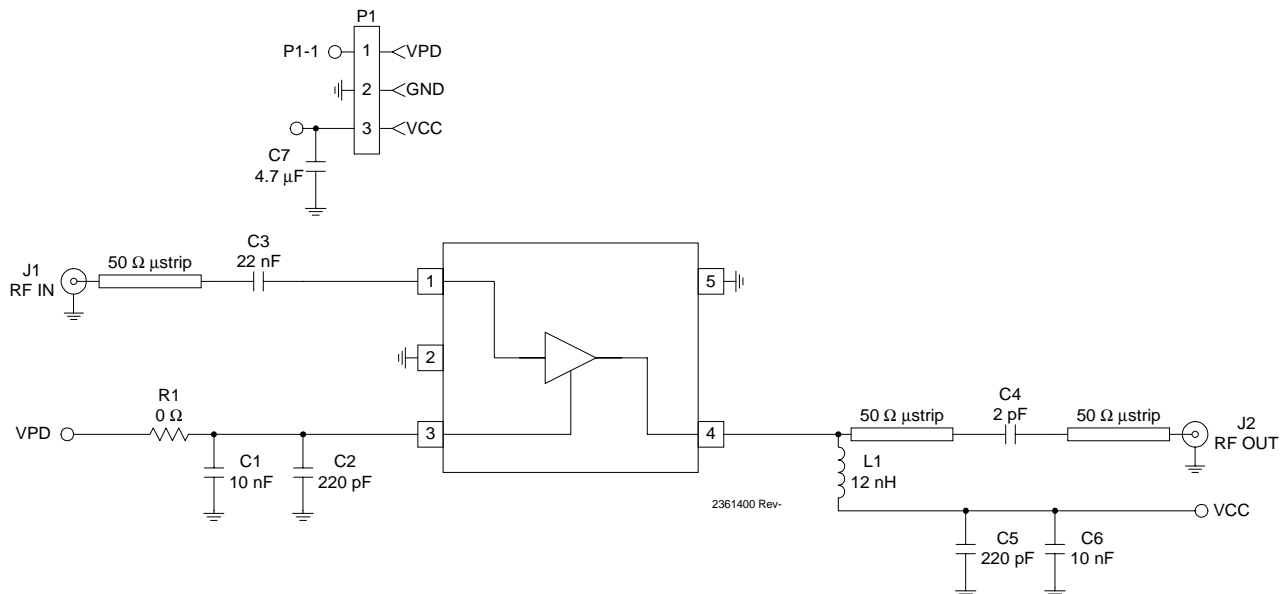

# RF2361

Evaluation Board Layout - 900MHz Driver  
Board Size 0.948" x 1.063"  
Board Thickness 0.031"; Board Material FR-4

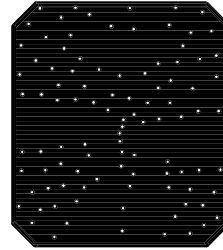
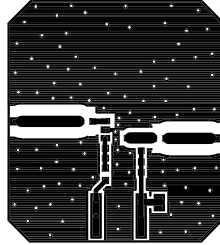
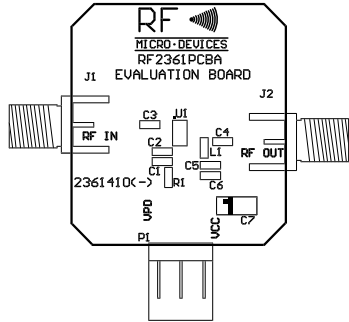

Evaluation Board Layout - 900MHz LNA

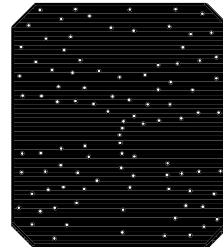
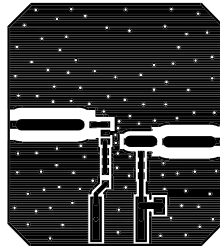
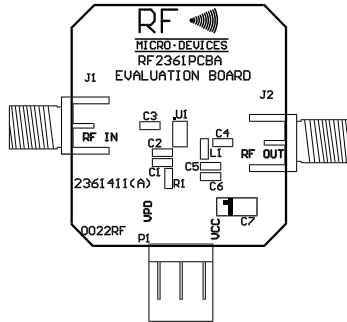



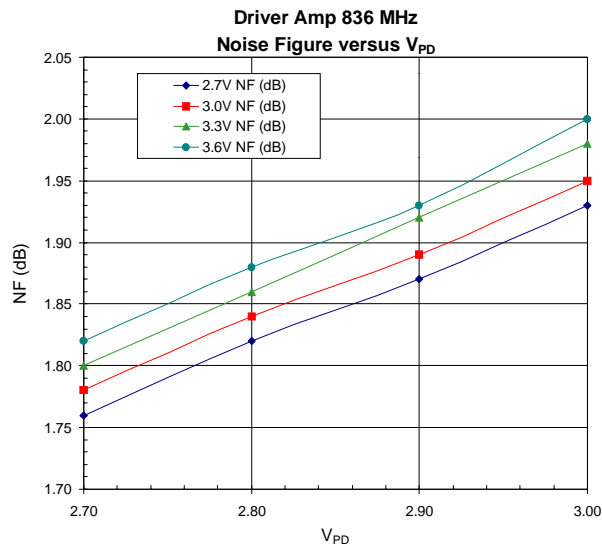
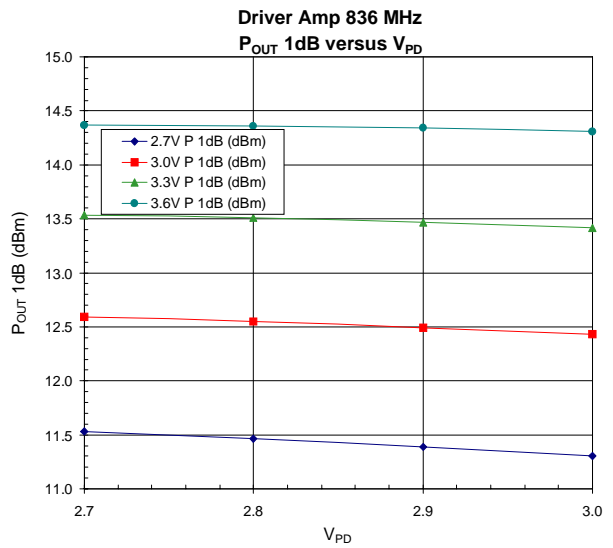
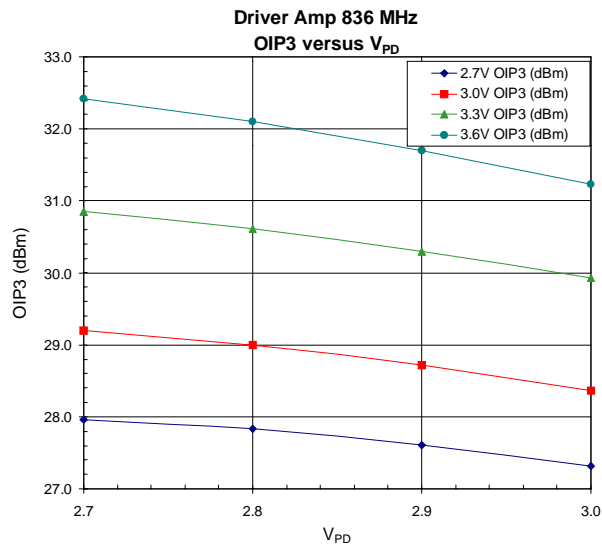
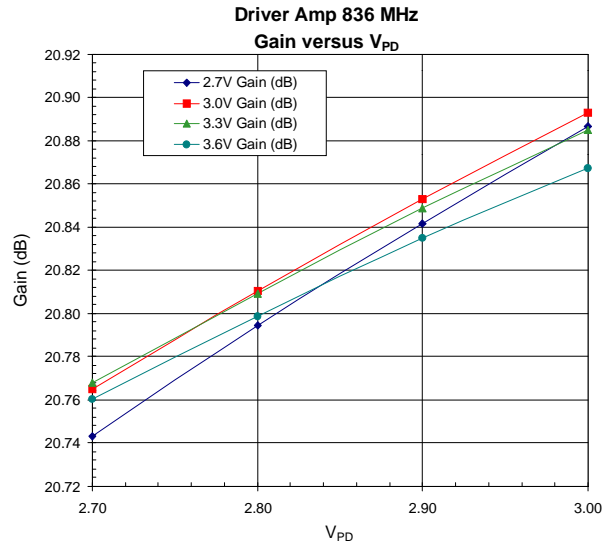
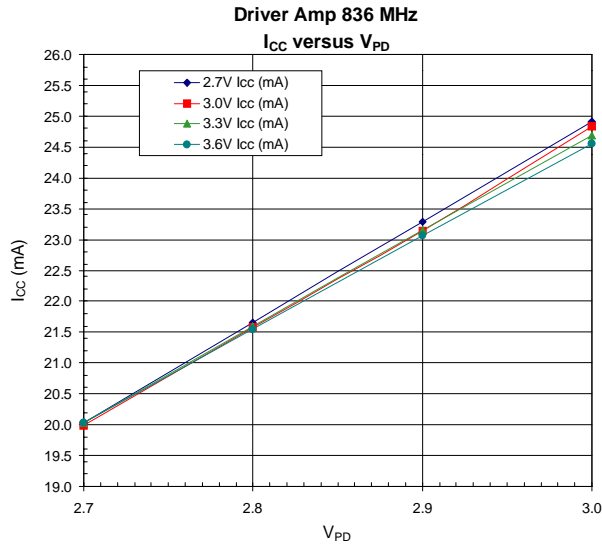

# RF2361

Low Noise Amplifier 881 MHz

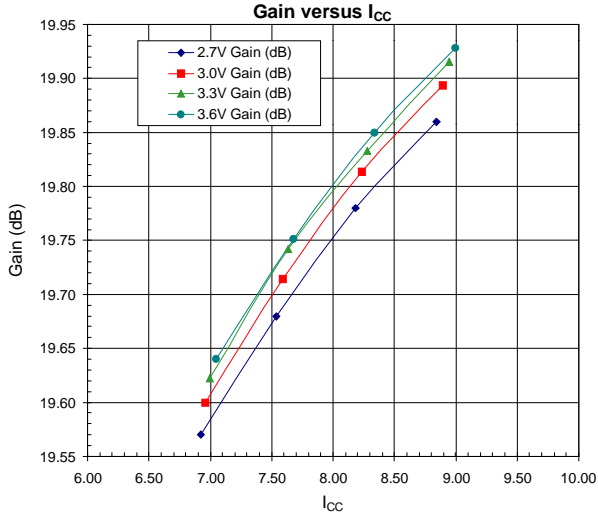

Low Noise Amplifier 881 MHz

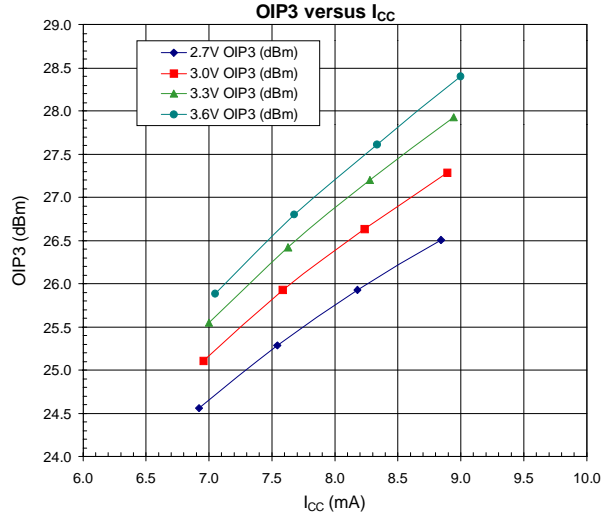

Low Noise Amplifier 881 MHz

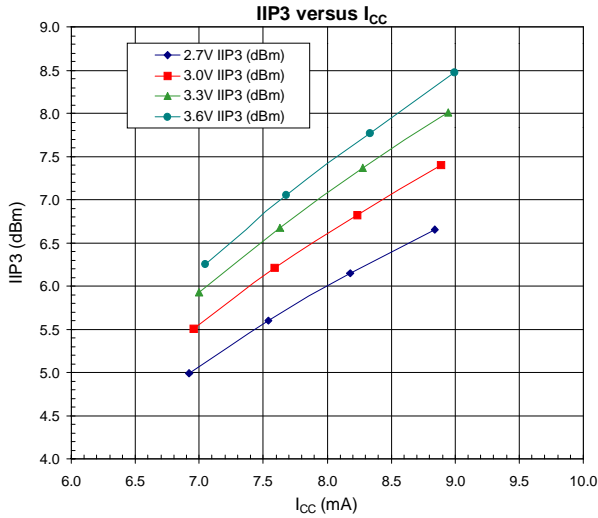

Low Noise Amplifier 881 MHz

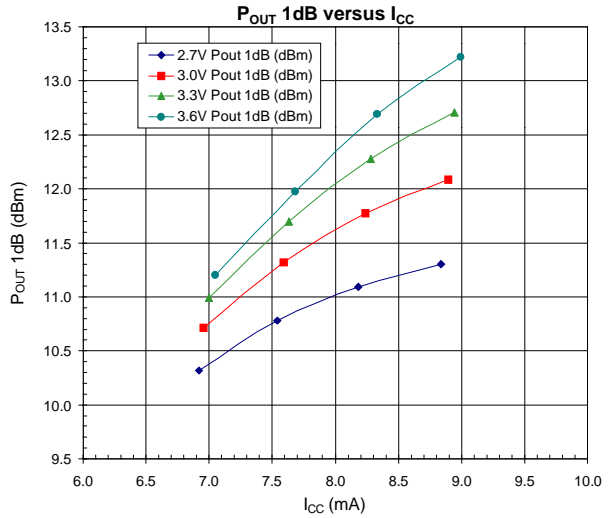

Low Noise Amplifier 881 MHz

