



RF2641

CDMA UP CONVERTER/BPSK MODULATOR

Typical Applications

- PCS/Cellular CDMA Systems
- PHS 1500/ WLAN 2400 Systems
- General Purpose Upconverter
- BPSK Modulation
- Micro-Cell PCS Base Stations
- Portable Battery-Powered Equipment

Product Description

The RF2641 is a complete upconverter designed for cellular and PCS applications. This device may also be used to directly BPSK modulate a carrier. The unit operates at 3.0V and is designed as part of the RFMD PCS/Cellular CDMA Chip Set, consisting of a Transmit IF AGC Amp, this Transmit Upconverter, a Receive LNA/Mixer, and a Receive IF AGC Amp.

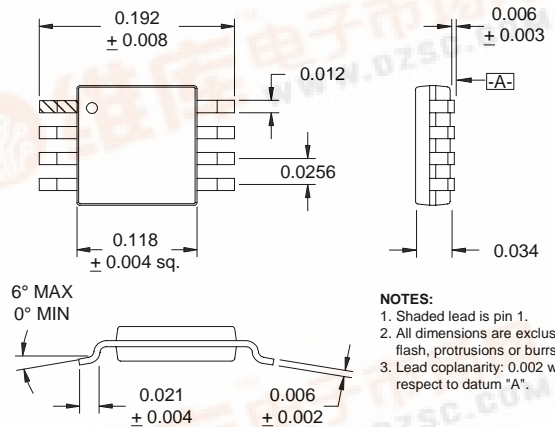

6

MIXERS

Optimum Technology Matching® Applied

- Si BJT
- GaAs HBT
- GaAs MESFET
- Si Bi-CMOS
- SiGe HBT
- Si CMOS

Package Style: MSOP-8

Features

- Supports Dual Mode Operation
- +5.5dBm Output Intercept Point
- 7 dB Conversion Gain (836MHz)
- Single 3.0V Power Supply
- Miniature 8 Pin Package
- Double-Balanced Mixer

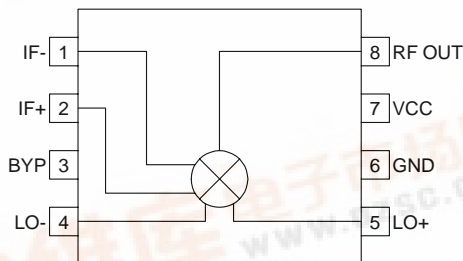

Functional Block Diagram

Ordering Information

- RF2641 CDMA Upconverter/BPSK Modulator
- RF2641 PCBA Fully Assembled Evaluation Board

RF Micro Devices, Inc.
7628 Thorndike Road
Greensboro, NC 27409, USA

Tel (336) 664 1233
Fax (336) 664 0454
http://www.rfmd.com



RF2641

Absolute Maximum Ratings

Parameter	Rating	Unit
Supply Voltage	-0.5 to +5.0	V _{DC}
Input RF Power	+3	dBm
Operating Ambient Temperature	-30 to +80	°C
Storage Temperature	-30 to +150	°C



Caution! ESD sensitive device.

RF Micro Devices believes the furnished information is correct and accurate at the time of this printing. However, RF Micro Devices reserves the right to make changes to its products without notice. RF Micro Devices does not assume responsibility for the use of the described product(s).

Parameter	Specification			Unit	Condition
	Min.	Typ.	Max.		
Overall					T=25°C, V _{CC} =3.0V, IF=130MHz
RF Output Frequency Range		500 to 2500		MHz	
Conversion Gain	5	7		dB	RF out=836MHz, LO=-3dBm @ 960MHz
Noise Figure		4		dB	RF out=1880MHz, LO=-3dBm @ 2010MHz
		10		dB	RF out=836MHz
		11		dB	RF out=1880MHz
Output IP3	+3	+5.5		dBm	P _{IN} =-18dBm per Tone, RF out=836MHz
		+4			P _{IN} =-18dBm per Tone, RF out=1880MHz
Spurious Product Rejection		30		dBc	Referenced to RF output
IF Input					
IF Frequency		DC to 300		MHz	
Differential Input Impedance		260		Ω	
IF to RF Output Isolation		30		dB	
IF to LO Isolation		30		dB	
LO Input					
LO Frequency Range		300 to 2700		MHz	
LO Level		-6 to 0		dBm	
LO to RF Output Leakage	-15	-20		dBm	
RF to LO Isolation		30		dB	
LO Input VSWR		2:1			50Ω
Power Supply					
Voltage		2.7 to 3.3		V	
Current Consumption		13	16	mA	

6

MIXERS

RF2641

Pin	Function	Description	Interface Schematic
1	IF-	Balanced IF input pin. This pin is internally DC-biased and should be DC-blocked if connected to a device with a DC level present. For single-ended input operation, one pin is used as an input and the other IF input is AC-coupled to ground. The balanced, as well as single-ended, input impedance is 260Ω.	
2	IF+	Same as pin 1, except complementary input.	See Pin 1.
3	BYP	Bypass pin for internal bias circuitry. Bypass with a 1 nF capacitor.	
4	LO-	Balanced LO input pin. This pin is internally DC-biased and should be DC-blocked if connected to a device with a DC level present. For single-ended input operation, one pin is used as an input and the other LO input is AC-coupled to ground. The balanced, as well as single-ended, input impedance is 50Ω.	
5	LO+	Same as pin 4, except complementary input.	See Pin 4.
6	GND	Ground connection. For best performance, keep traces physically short and connect immediately to ground plane.	
7	VCC	Supply voltage pin. External bypassing is required. External RF, LO, and IF bypassing is required. The trace length between the pin and the bypass capacitors should be minimized. The ground side of the bypass capacitors should connect immediately to ground plane.	
8	RF OUT	RF output pin.	

RF2641

Application Schematic 836MHz

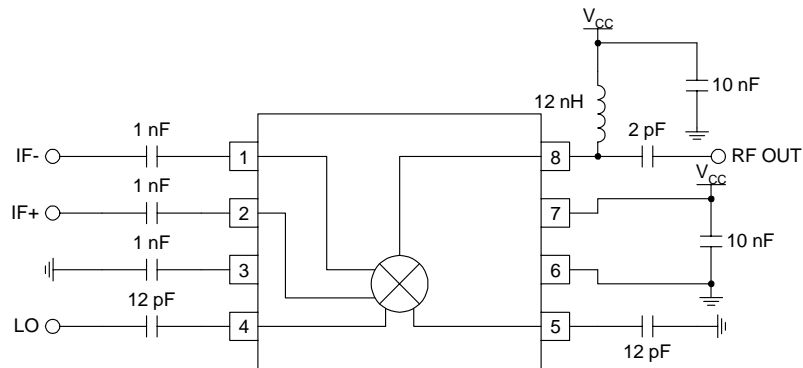

Application Schematic 1880MHz

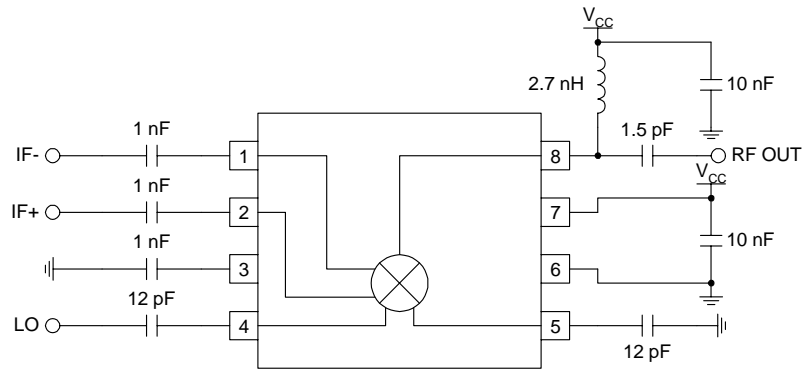

Evaluation Board Schematic PCS Board

(Download [Bill of Materials](http://www.rfmd.com) from www.rfmd.com.)

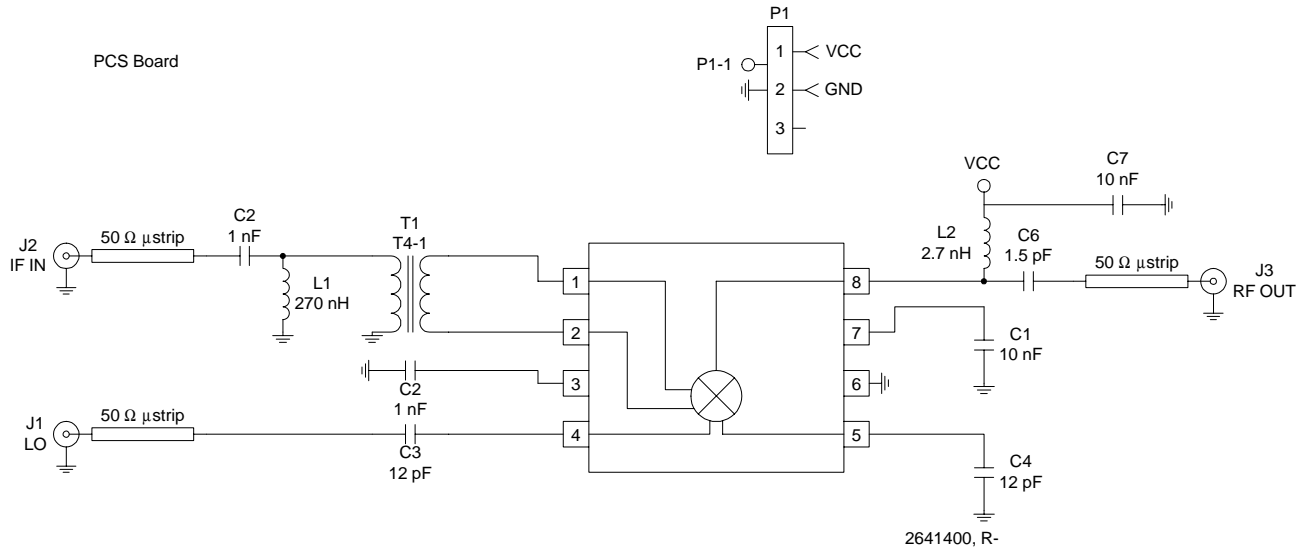

Evaluation Board Schematic Cellular Board

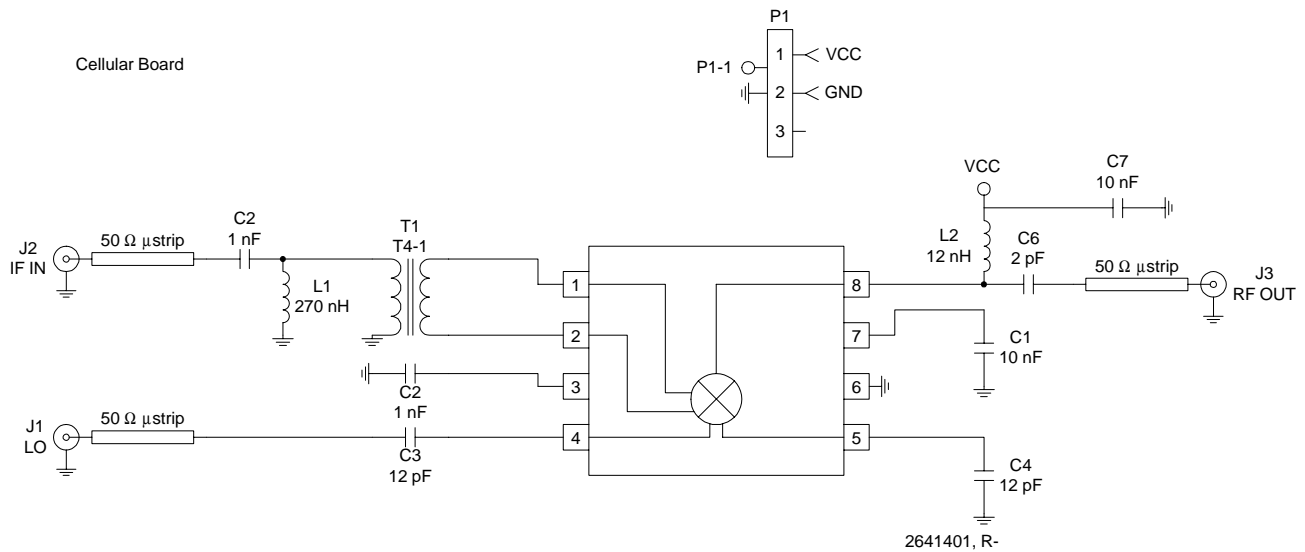

RF2641

Evaluation Board Layout Board Thickness 0.014"; Board Material FR-4

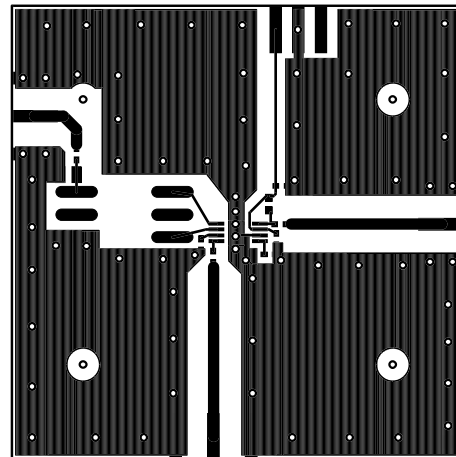
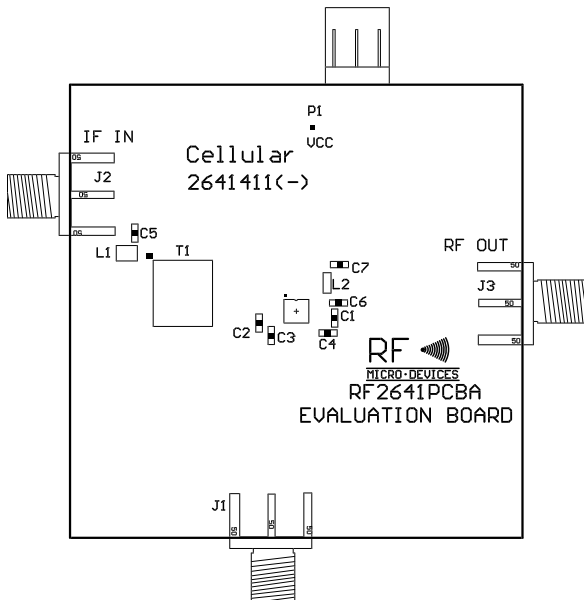
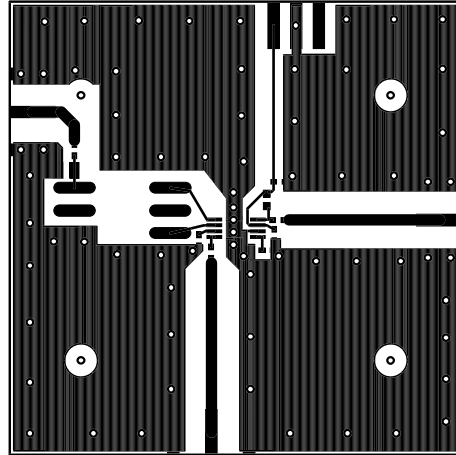
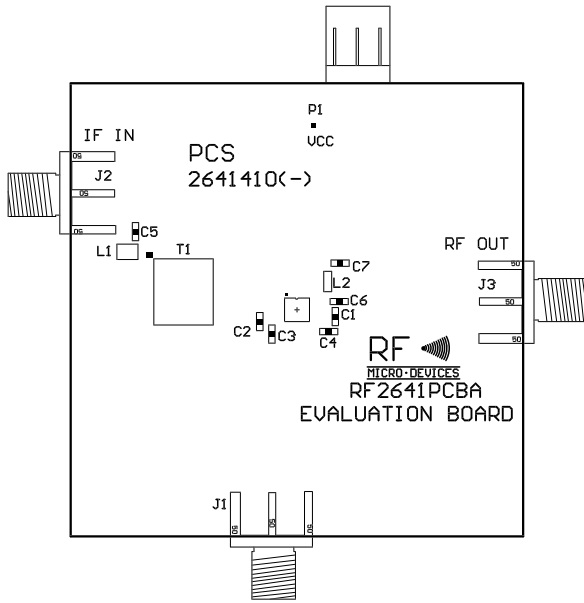

6

MIXERS