

INTEGRATED CIRCUITS

DATA SHEET

For a complete data sheet, please also download:

- The IC04 LOCMOS HE4000B Logic Family Specifications HEF, HEC
- The IC04 LOCMOS HE4000B Logic Package Outlines/Information HEF, HEC

HEF4518B MSI Dual BCD counter

Product specification
File under Integrated Circuits, IC04

January 1995

Dual BCD counter

HEF4518B
MSI

DESCRIPTION

The HEF4518B is a dual 4-bit internally synchronous BCD counter. The counter has an active HIGH clock input (CP₀) and an active LOW clock input (\overline{CP}_1), buffered outputs from all four bit positions (O₀ to O₃) and an active HIGH overriding asynchronous master reset input (MR). The counter advances on either the LOW to HIGH transition of the CP₀ input if \overline{CP}_1 is HIGH or the HIGH to

LOW transition of the \overline{CP}_1 input if CP₀ is LOW. Either CP₀ or \overline{CP}_1 may be used as the clock input to the counter and the other clock input may be used as a clock enable input. A HIGH on MR resets the counter (O₀ to O₃ = LOW) independent of CP₀, \overline{CP}_1 . Schmitt-trigger action in the clock input makes the circuit highly tolerant to slower clock rise and fall times.

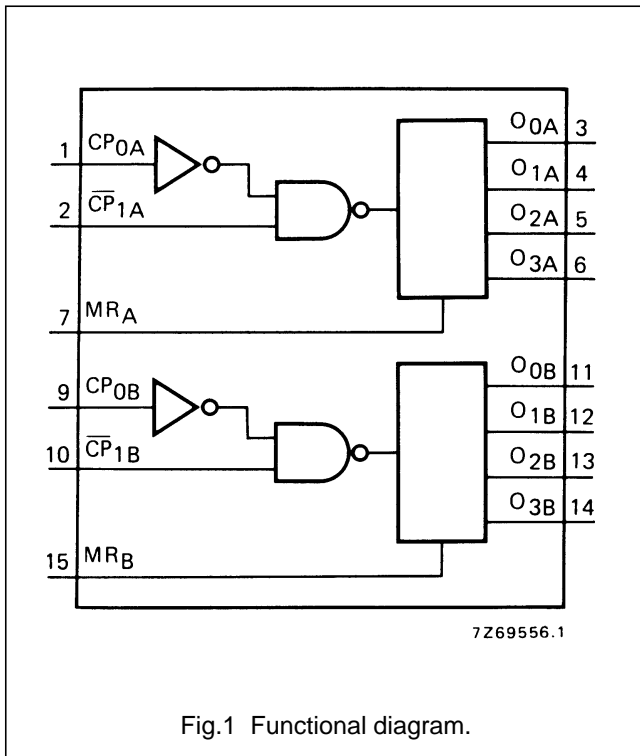

Fig.1 Functional diagram.

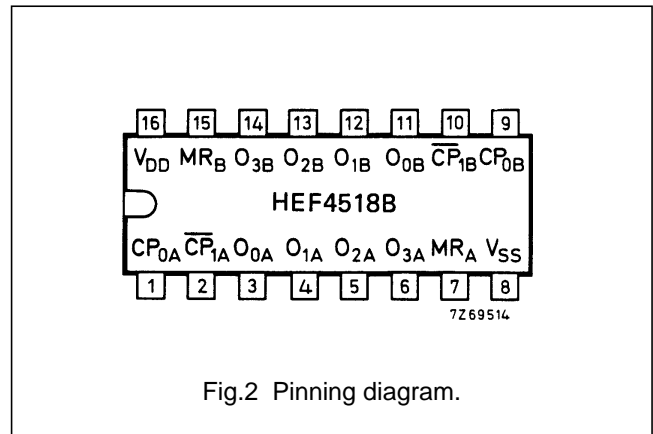

Fig.2 Pinning diagram.

PINNING

- CP_{0A}, CP_{0B} clock inputs (L to H triggered)
- \overline{CP}_{1A} , \overline{CP}_{1B} clock inputs (H to L triggered)
- MRA, MRB master reset inputs
- O_{0A} to O_{3A} outputs
- O_{0B} to O_{3B} outputs

APPLICATION INFORMATION

Some examples of applications for the HEF4518B are:

- Multistage synchronous counting.
- Multistage asynchronous counting.
- Frequency dividers.

FAMILY DATA, I_{DD} LIMITS category MSI

See Family Specifications

Dual BCD counter

HEF4518B
MSI

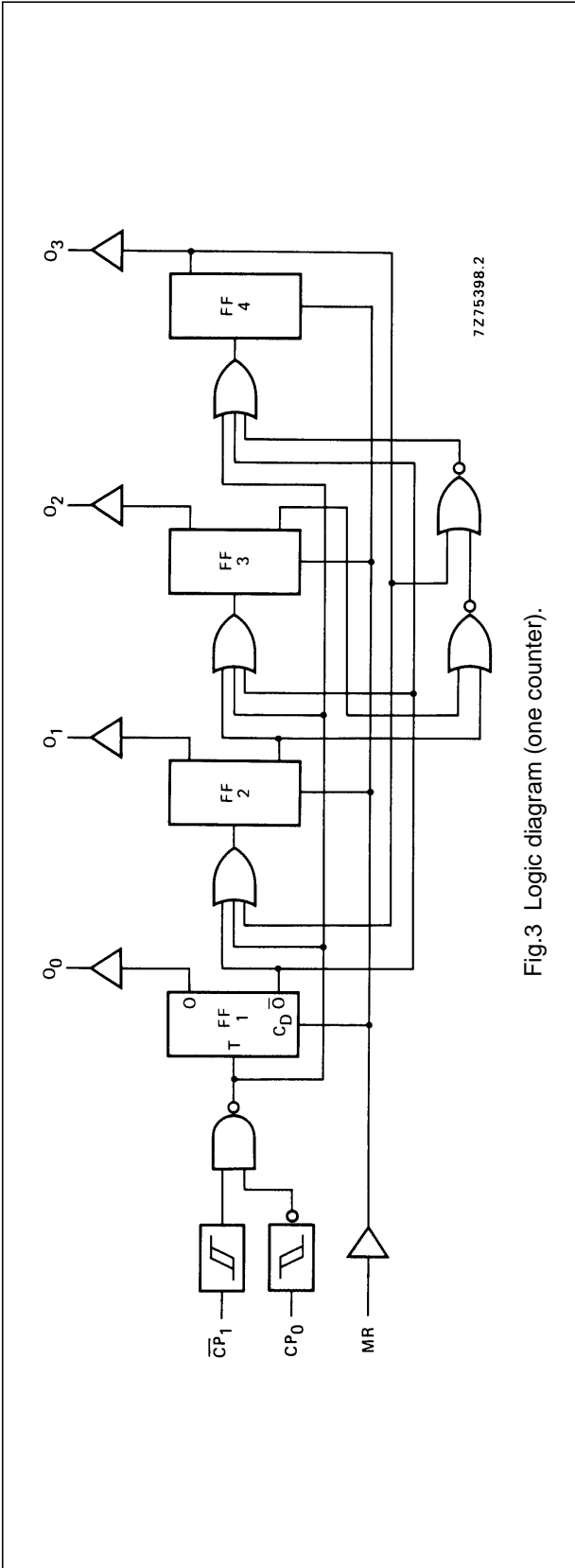

Fig.3 Logic diagram (one counter).

FUNCTION TABLE

CP ₀	CP ₁	MR	MODE
✓	H	L	counter advances
L	↘	L	counter advances
↘	X	L	no change
X	✓	L	no change
✓	L	L	no change
H	↘	L	no change
X	X	H	O ₀ to O ₃ = LOW

Notes

1. H = HIGH state (the more positive voltage)
 L = LOW state (the less positive voltage)
 X = state is immaterial
 ✓ = positive-going transition
 ↘ = negative-going transition

Dual BCD counter

HEF4518B
MSI

AC CHARACTERISTICS

 $V_{SS} = 0\text{ V}$; $T_{amb} = 25\text{ }^\circ\text{C}$; $C_L = 50\text{ pF}$; input transition times $\leq 20\text{ ns}$

	V_{DD} V	SYMBOL	MIN.	TYP.	MAX.	TYPICAL EXTRAPOLATION FORMULA
Propagation delays $CP_0, \overline{CP}_1 \rightarrow O_n$ HIGH to LOW LOW to HIGH MR $\rightarrow O_n$ HIGH to LOW	5 10 15	t_{PHL}	120	240	ns	$93\text{ ns} + (0,55\text{ ns/pF}) C_L$
			55	110	ns	$44\text{ ns} + (0,23\text{ ns/pF}) C_L$
			40	80	ns	$32\text{ ns} + (0,16\text{ ns/pF}) C_L$
	5 10 15	t_{PLH}	120	240	ns	$93\text{ ns} + (0,55\text{ ns/pF}) C_L$
			55	110	ns	$44\text{ ns} + (0,23\text{ ns/pF}) C_L$
			40	80	ns	$32\text{ ns} + (0,16\text{ ns/pF}) C_L$
	5 10 15	t_{PHL}	75	150	ns	$48\text{ ns} + (0,55\text{ ns/pF}) C_L$
			35	70	ns	$24\text{ ns} + (0,23\text{ ns/pF}) C_L$
			25	50	ns	$17\text{ ns} + (0,16\text{ ns/pF}) C_L$
Output transition times HIGH to LOW LOW to HIGH	5 10 15	t_{THL}	60	120	ns	$10\text{ ns} + (1,0\text{ ns/pF}) C_L$
			30	60	ns	$9\text{ ns} + (0,42\text{ ns/pF}) C_L$
			20	40	ns	$6\text{ ns} + (0,28\text{ ns/pF}) C_L$
	5 10 15	t_{TLH}	60	120	ns	$10\text{ ns} + (1,0\text{ ns/pF}) C_L$
			30	60	ns	$9\text{ ns} + (0,42\text{ ns/pF}) C_L$
			20	40	ns	$6\text{ ns} + (0,28\text{ ns/pF}) C_L$
Minimum CP_0 pulse width; LOW	5	t_{WCPL}	60	30	ns	see also waveforms Figs 4 and 5
	10		30	15	ns	
	15		20	10	ns	
Minimum \overline{CP}_1 pulse width; HIGH	5	t_{WCPH}	60	30	ns	
	10		30	15	ns	
	15		20	10	ns	
Minimum MR pulse width; HIGH	5	t_{WMRH}	30	15	ns	
	10		20	10	ns	
	15		16	8	ns	
Recovery time for MR	5	t_{RMR}	50	25	ns	
	10		30	15	ns	
	15		20	10	ns	
Set-up times $CP_0 \rightarrow \overline{CP}_1$ $\overline{CP}_1 \rightarrow CP_0$	5 10 15	t_{su}	50	25	ns	
			30	15	ns	
			20	10	ns	
	5 10 15	t_{su}	50	25	ns	
			30	15	ns	
			20	10	ns	
Maximum clock pulse frequency	5	f_{max}	8	16	MHz	
	10		15	30	MHz	
	15		20	40	MHz	

Dual BCD counter

HEF4518B
MSI

AC CHARACTERISTICS

$V_{SS} = 0\text{ V}$; $T_{amb} = 25\text{ }^\circ\text{C}$; input transition times $\leq 20\text{ ns}$

	V_{DD} V	TYPICAL FORMULA FOR P (μW)	
Dynamic power dissipation per package (P)	5	$750f_i + \sum (f_o C_L) \times V_{DD}^2$	where f_i = input freq. (MHz) f_o = output freq. (MHz) C_L = load capacitance (pF) $\sum (f_o C_L)$ = sum of outputs V_{DD} = supply voltage (V)
	10	$3300 f_i + \sum (f_o C_L) \times V_{DD}^2$	
	15	$8000 f_i + \sum (f_o C_L) \times V_{DD}^2$	

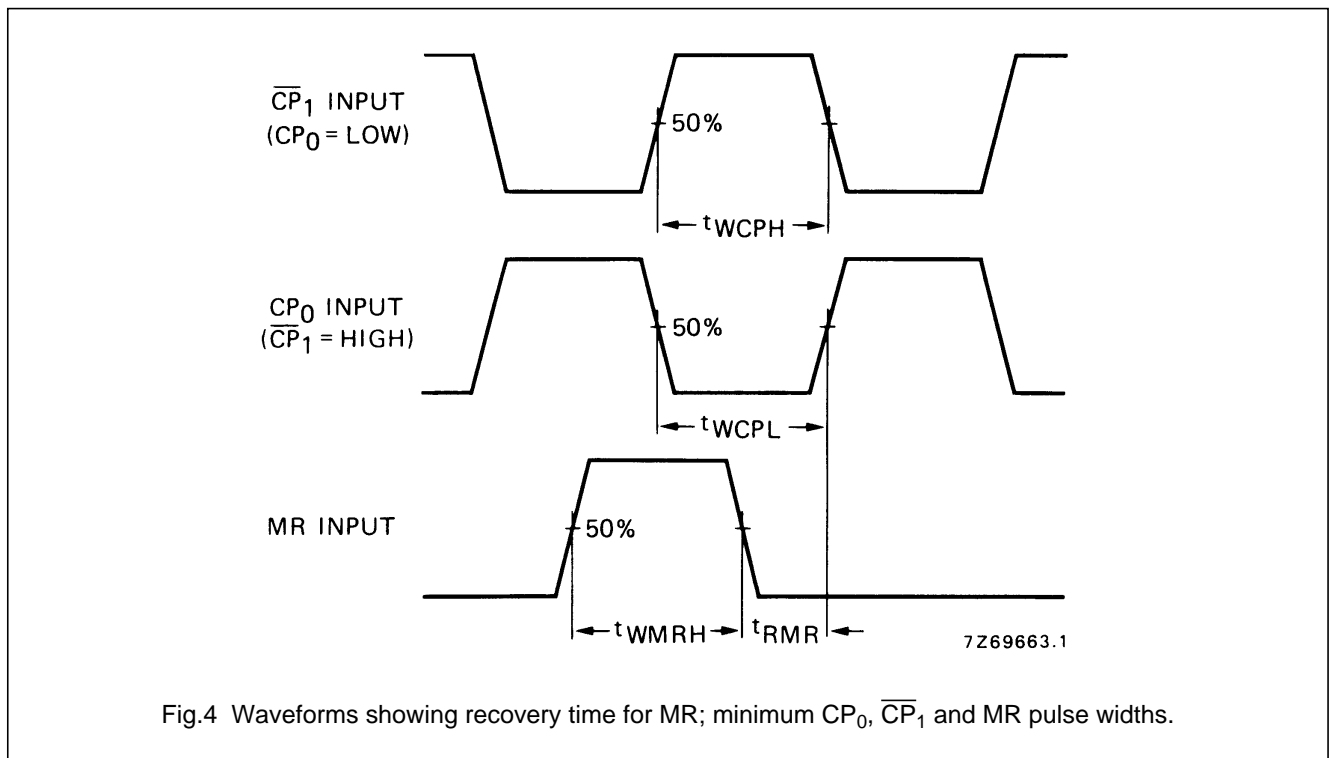
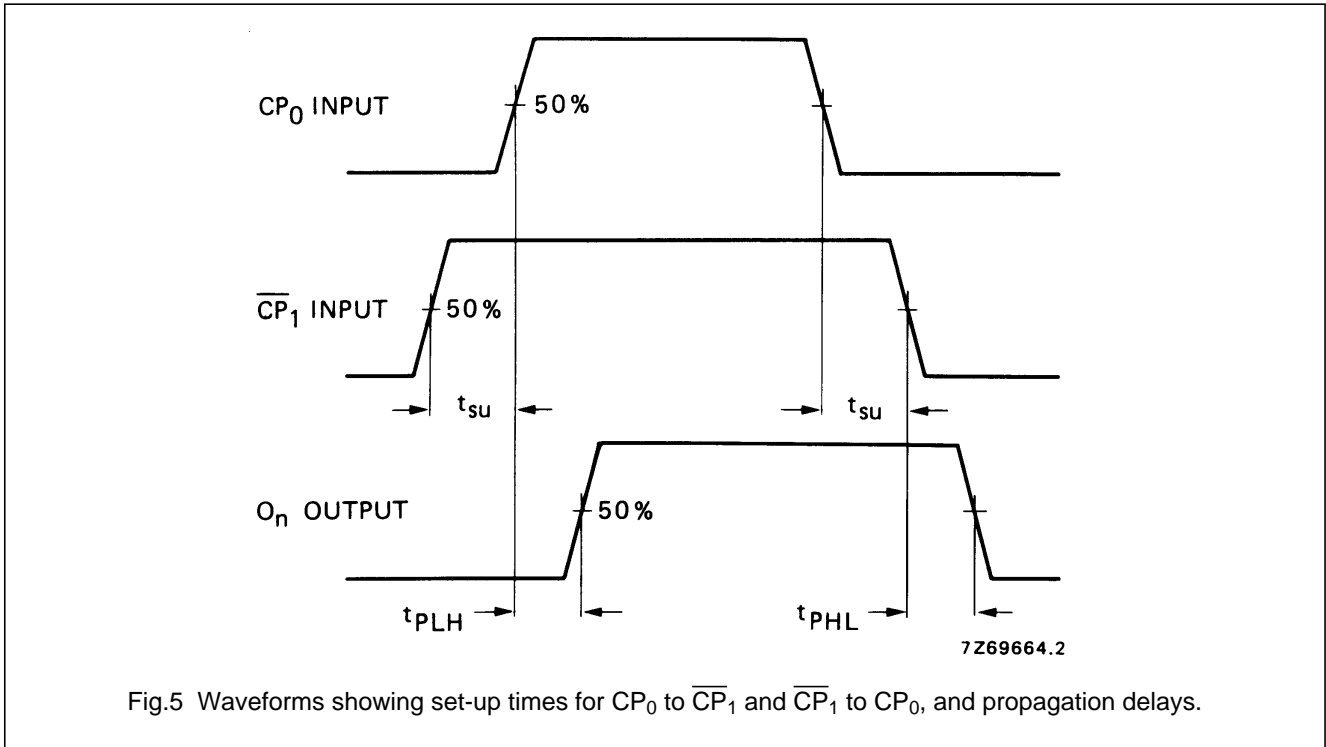

Fig.4 Waveforms showing recovery time for MR; minimum CP_0 , \overline{CP}_1 and MR pulse widths.

Dual BCD counter

HEF4518B
MSI



Dual BCD counter

HEF4518B
MSI

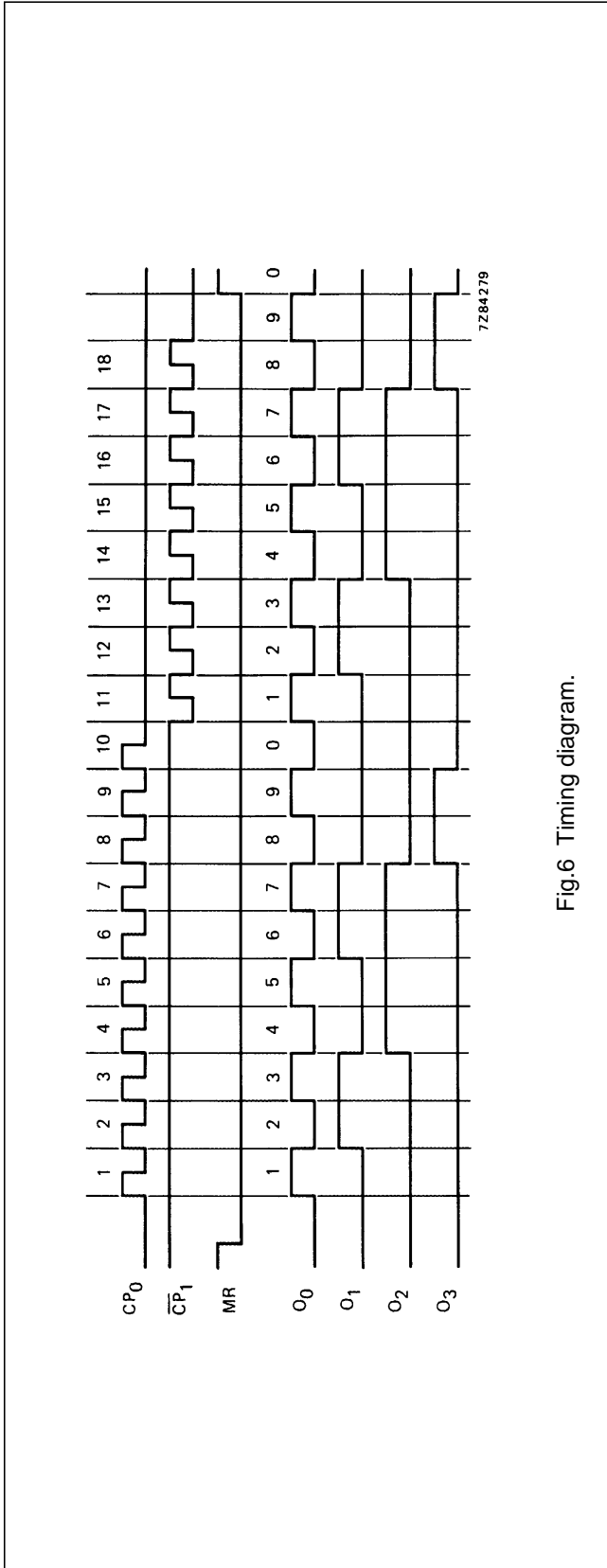

Fig.6 Timing diagram.