

International  
**IR Rectifier**

**SMPS MOSFET**

PD- 94094A

**IRF7477**

HEXFET® Power MOSFET

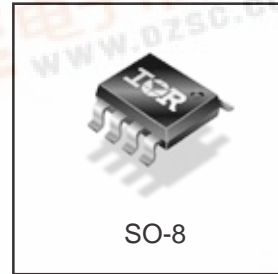
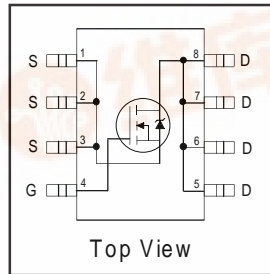
**Applications**

- High Frequency Synchronous Buck Converters for Computers and Communications

**Benefits**

- Ultra-Low Gate Impedance
- Very Low  $R_{DS(on)}$
- Fully Characterized Avalanche Voltage and Current
- Low Charge Ratio to Eliminate False Turn On in High Frequency Circuits

| $V_{DSS}$ | $R_{DS(on)}$ max (mΩ) | $I_D$ |
|-----------|-----------------------|-------|
| 30V       | 8.5@ $V_{GS} = 10V$   | 14A   |
|           | 10@ $V_{GS} = 4.5V$   | 11A   |



**Absolute Maximum Ratings**

| Symbol                   | Parameter                                | Max.         | Units |
|--------------------------|--|--------------|-------|
| $V_{DS}$                 | Drain-Source Voltage                     | 30           | V     |
| $V_{GS}$                 | Gate-to-Source Voltage                   | ± 20         | V     |
| $I_D @ T_A = 25^\circ C$ | Continuous Drain Current, $V_{GS} @ 10V$ | 14           | A     |
| $I_D @ T_A = 70^\circ C$ | Continuous Drain Current, $V_{GS} @ 10V$ | 11           |       |
| $I_{DM}$                 | Pulsed Drain Current①                    | 110          |       |
| $P_D @ T_A = 25^\circ C$ | Maximum Power Dissipation④               | 2.5          | W     |
| $P_D @ T_A = 70^\circ C$ | Maximum Power Dissipation④               | 1.6          | W     |
|                          | Linear Derating Factor                   | 0.02         | mW/°C |
| $T_J, T_{STG}$           | Junction and Storage Temperature Range   | -55 to + 150 | °C    |

**Thermal Resistance**

| Symbol          | Parameter              | Typ. | Max. | Units |
|-----------------|------------------------|------|------|-------|
| $R_{\theta JL}$ | Junction-to-Drain Lead | —    | 20   | °C/W  |
| $R_{\theta JA}$ | Junction-to-Ambient ④  | —    | 50   |       |

Notes ① through ④ are on page 8  
www.irf.com



# IRF7477

International  
IR Rectifier

## Static @ T<sub>J</sub> = 25°C (unless otherwise specified)

|  | Parameter                            | Min. | Typ.  | Max. | Units | Conditions  |
|--|--------------------------------------|------|-------|------|-------|---|
| V <sub>(BR)DSS</sub>                   | Drain-to-Source Breakdown Voltage    | 30   | —     | —    | V     | V <sub>GS</sub> = 0V, I <sub>D</sub> = 250μA                        |
| ΔV <sub>(BR)DSS</sub> /ΔT <sub>J</sub> | Breakdown Voltage Temp. Coefficient  | —    | 0.029 | —    | V/°C  | Reference to 25°C, I <sub>D</sub> = 1mA                             |
| R <sub>DS(on)</sub>                    | Static Drain-to-Source On-Resistance | —    | 6.5   | 8.5  | mΩ    | V <sub>GS</sub> = 10V, I <sub>D</sub> = 14A ③                       |
|  |                                      | —    | 7.7   | 10   |       | V <sub>GS</sub> = 4.5V, I <sub>D</sub> = 11A ③                      |
| V <sub>GS(th)</sub>                    | Gate Threshold Voltage               | 1.0  | —     | 2.5  | V     | V <sub>DS</sub> = V <sub>GS</sub> , I <sub>D</sub> = 250μA          |
| I <sub>DSS</sub>                       | Drain-to-Source Leakage Current      | —    | —     | 20   | μA    | V <sub>DS</sub> = 24V, V <sub>GS</sub> = 0V                         |
|  |                                      | —    | —     | 100  |       | V <sub>DS</sub> = 24V, V <sub>GS</sub> = 0V, T <sub>J</sub> = 125°C |
| I <sub>GSS</sub>                       | Gate-to-Source Forward Leakage       | —    | —     | 200  | nA    | V <sub>GS</sub> = 16V   |
|  | Gate-to-Source Reverse Leakage       | —    | —     | -200 |       | V <sub>GS</sub> = -16V  |

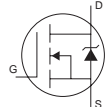
## Dynamic @ T<sub>J</sub> = 25°C (unless otherwise specified)

| Symbol              | Parameter                       | Min. | Typ. | Max. | Units | Conditions                                  |
|---------------------|---------------------------------|------|------|------|-------|---|
| g <sub>fs</sub>     | Forward Transconductance        | 35   | —    | —    | S     | V <sub>DS</sub> = 15V, I <sub>D</sub> = 11A |
| Q <sub>g</sub>      | Total Gate Charge               | —    | 25   | 38   | nC    | I <sub>D</sub> = 11A                        |
| Q <sub>gs</sub>     | Gate-to-Source Charge           | —    | 6.5  | —    |       | V <sub>DS</sub> = 15V                       |
| Q <sub>gd</sub>     | Gate-to-Drain ("Miller") Charge | —    | 8.2  | —    |       | V <sub>GS</sub> = 4.5V                      |
| Q <sub>oss</sub>    | Output Gate Charge              | —    | 30   | —    |       | V <sub>GS</sub> = 0V, V <sub>DS</sub> = 15V |
| t <sub>d(on)</sub>  | Turn-On Delay Time              | —    | 12   | —    | ns    | V <sub>DD</sub> = 15V                       |
| t <sub>r</sub>      | Rise Time                       | —    | 9.8  | —    |       | I <sub>D</sub> = 11A                        |
| t <sub>d(off)</sub> | Turn-Off Delay Time             | —    | 19   | —    |       | R <sub>G</sub> = 1.8Ω                       |
| t <sub>f</sub>      | Fall Time                       | —    | 5.9  | —    |       | V <sub>GS</sub> = 4.5V ③                    |
| C <sub>iss</sub>    | Input Capacitance               | —    | 2710 | —    | pF    | V <sub>GS</sub> = 0V                        |
| C <sub>oss</sub>    | Output Capacitance              | —    | 1120 | —    |       | V <sub>DS</sub> = 15V                       |
| C <sub>rss</sub>    | Reverse Transfer Capacitance    | —    | 100  | —    |       | f = 1.0MHz                                  |

## Avalanche Characteristics

| Symbol          | Parameter                      | Typ. | Max. | Units |
|-----------------|--------------------------------|------|------|-------|
| E <sub>AS</sub> | Single Pulse Avalanche Energy② | —    | 500  | mJ    |
| I <sub>AR</sub> | Avalanche Current①             | —    | 8.2  | A     |

## Diode Characteristics

| Symbol          | Parameter                              | Min. | Typ. | Max. | Units | Conditions   |
|-----------------|--|------|------|------|-------|--|
| I <sub>S</sub>  | Continuous Source Current (Body Diode) | —    | —    | 2.3  | A     | MOSFET symbol showing the integral reverse p-n junction diode.  |
| I <sub>SM</sub> | Pulsed Source Current (Body Diode) ①   | —    | —    | 110  |       |  |
| V <sub>SD</sub> | Diode Forward Voltage                  | —    | 0.80 | 1.3  | V     | T <sub>J</sub> = 25°C, I <sub>S</sub> = 11A, V <sub>GS</sub> = 0V ③  |
|                 |  | —    | 0.65 | —    |       | T <sub>J</sub> = 125°C, I <sub>S</sub> = 11A, V <sub>GS</sub> = 0V ③   |
| t <sub>rr</sub> | Reverse Recovery Time                  | —    | 91   | 140  | ns    | T <sub>J</sub> = 25°C, I <sub>F</sub> = 11A, V <sub>R</sub> = 15V  |
| Q <sub>rr</sub> | Reverse Recovery Charge                | —    | 130  | 200  | nC    | di/dt = 100A/μs ③  |
| t <sub>rr</sub> | Reverse Recovery Time                  | —    | 90   | 140  | ns    | T <sub>J</sub> = 125°C, I <sub>F</sub> = 11A, V <sub>R</sub> = 15V   |
| Q <sub>rr</sub> | Reverse Recovery Charge                | —    | 140  | 210  | nC    | di/dt = 100A/μs ③  |

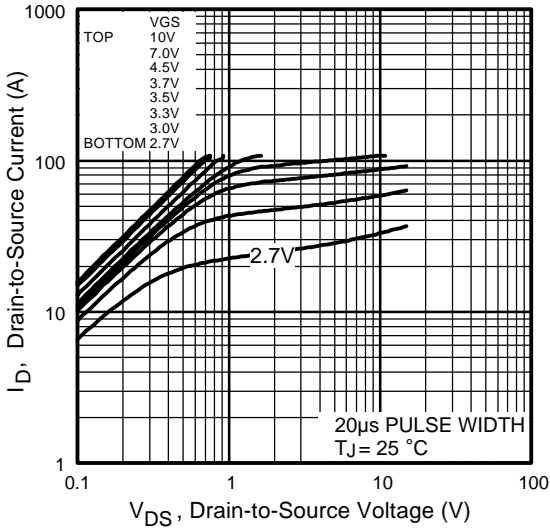


Fig 1. Typical Output Characteristics

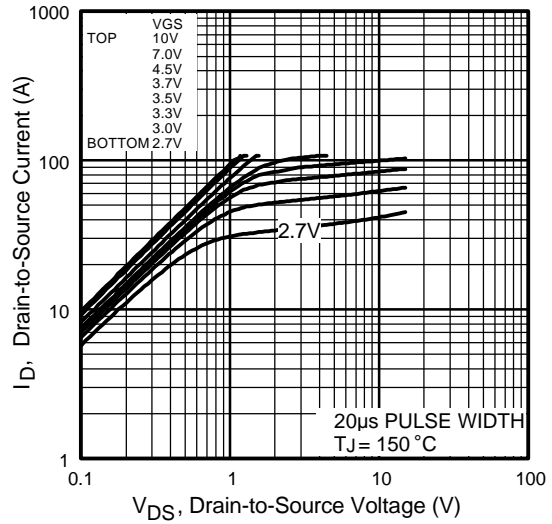


Fig 2. Typical Output Characteristics

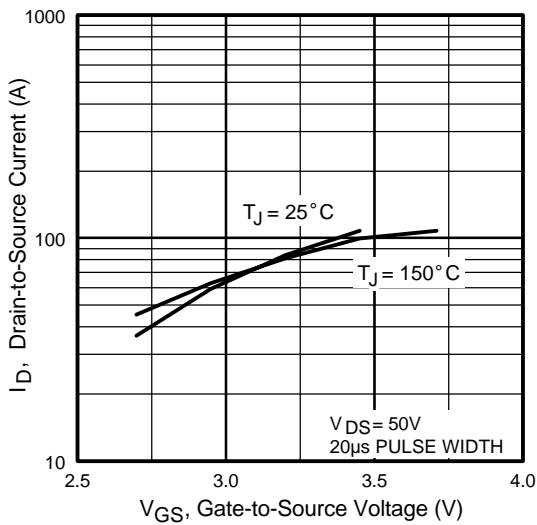


Fig 3. Typical Transfer Characteristics

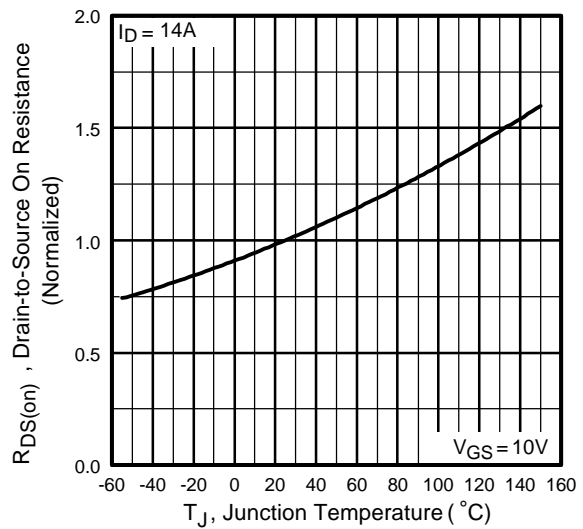
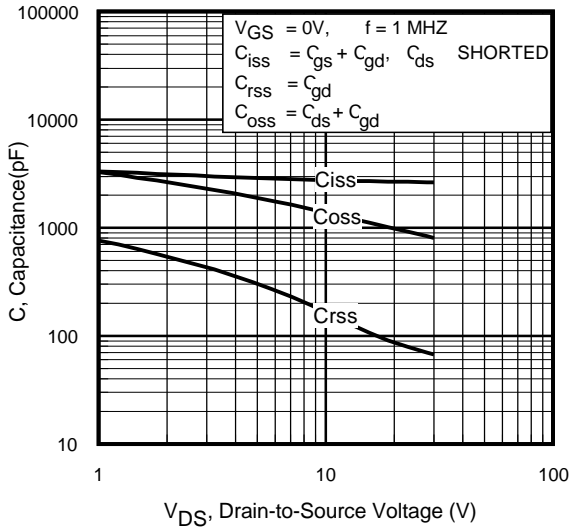
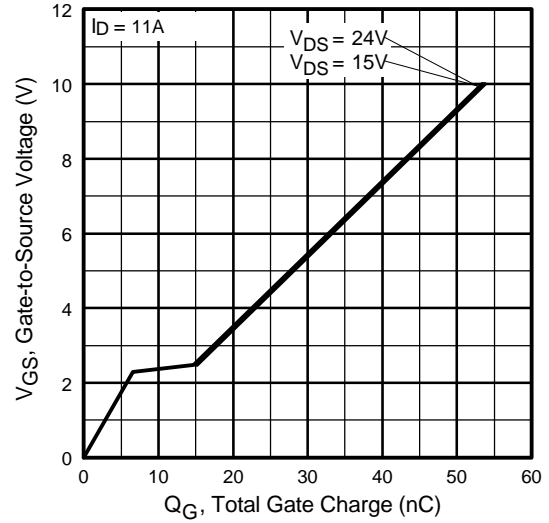


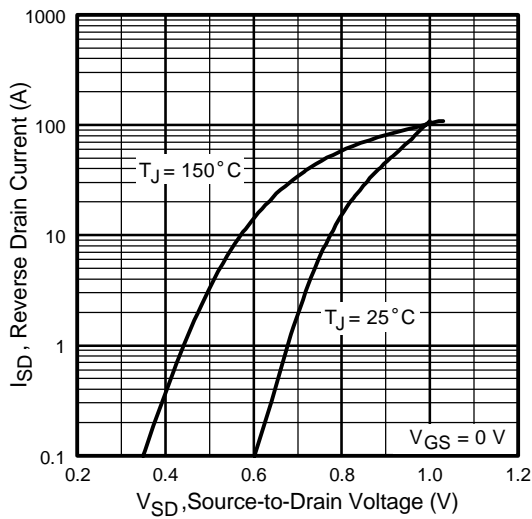
Fig 4. Normalized On-Resistance Vs. Temperature



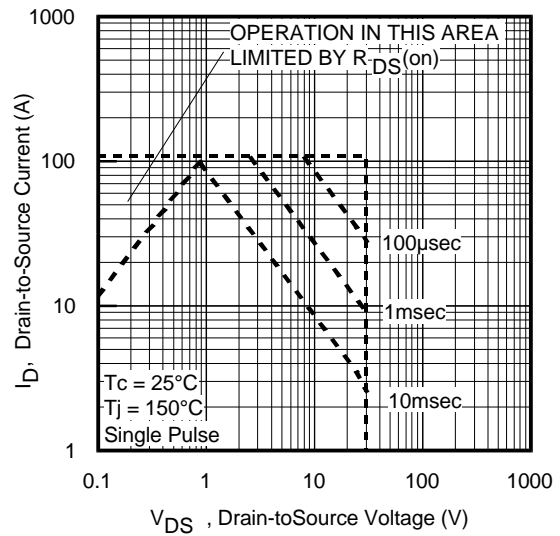
**Fig 5.** Typical Capacitance Vs. Drain-to-Source Voltage



**Fig 6.** Typical Gate Charge Vs. Gate-to-Source Voltage



**Fig 7.** Typical Source-Drain Diode Forward Voltage

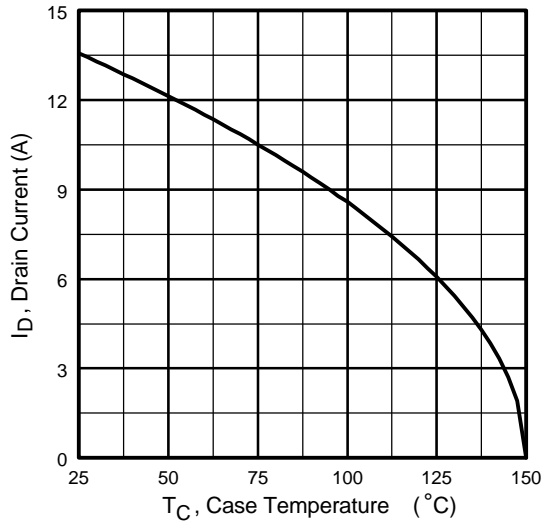


**Fig 8.** Maximum Safe Operating Area

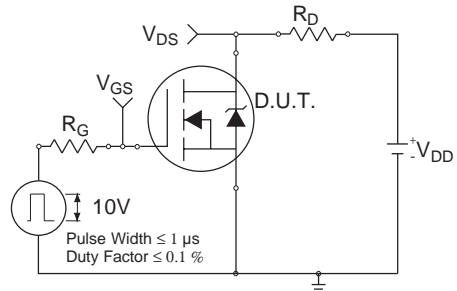
**Fig 6.** On-Resistance Vs. Drain Current

International  
**IRF** Rectifier

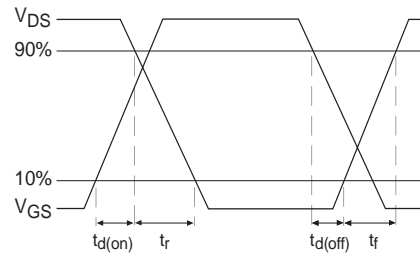
**IRF7477**



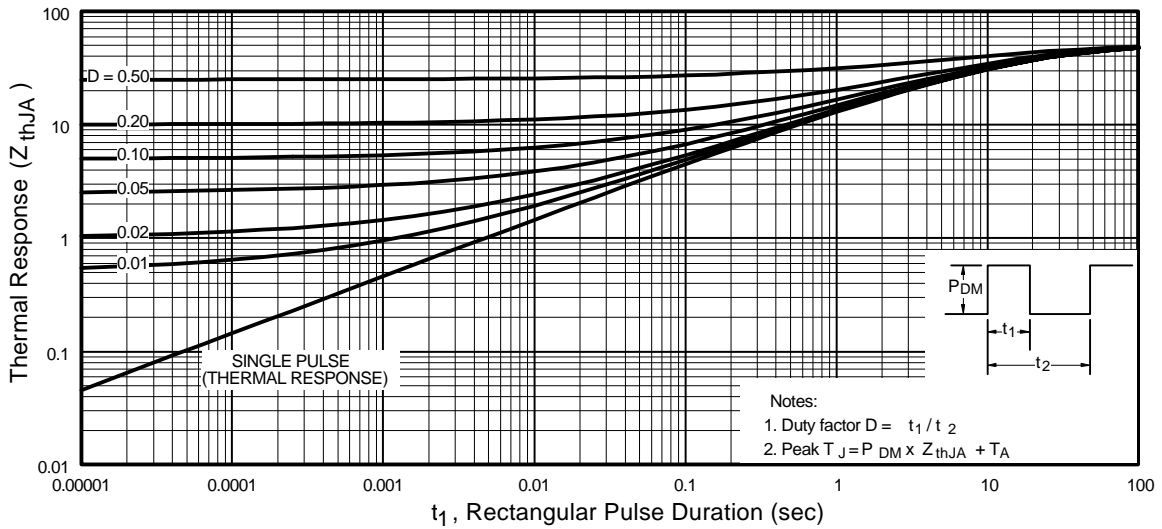
**Fig 9.** Maximum Drain Current Vs. Ambient Temperature



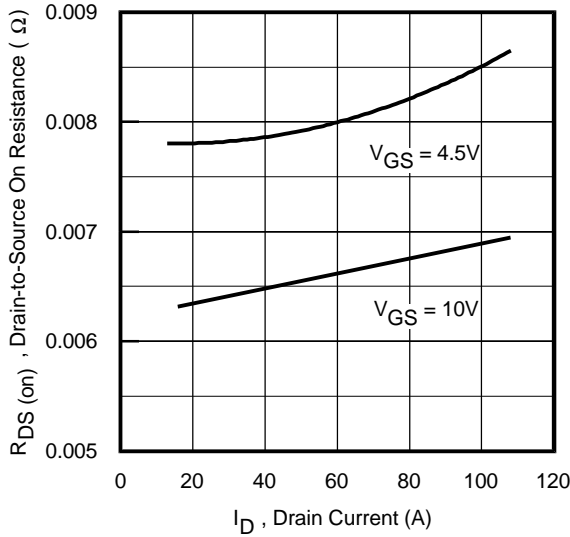
**Fig 10a.** Switching Time Test Circuit



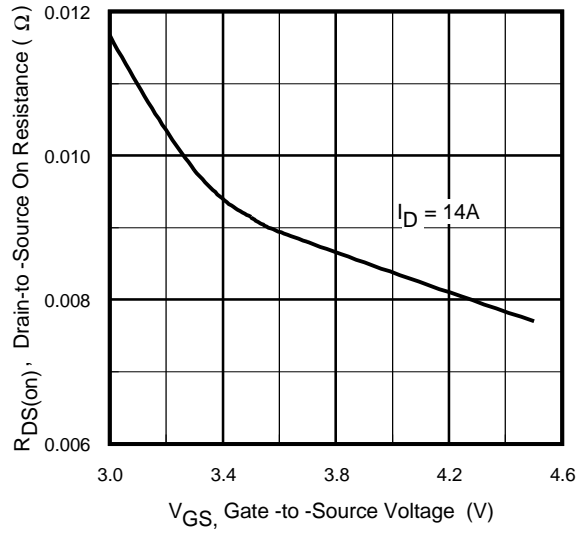
**Fig 10b.** Switching Time Waveforms



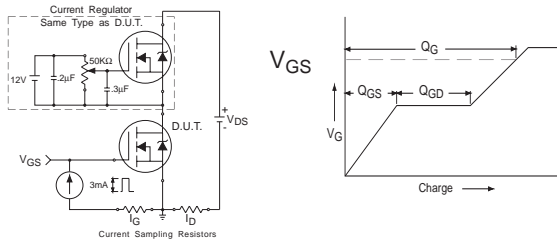
**Fig 11.** Maximum Effective Transient Thermal Impedance, Junction-to-Ambient



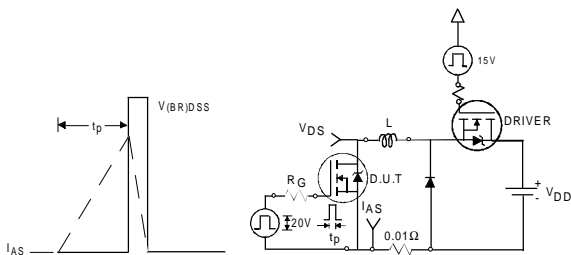
**Fig 12.** On-Resistance Vs. Drain Current



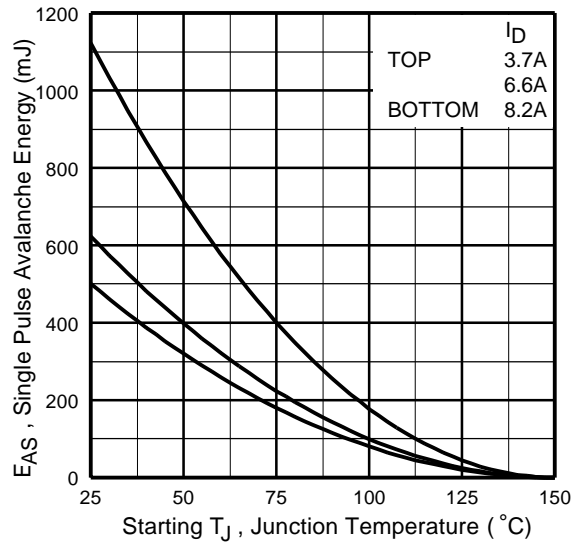
**Fig 13.** On-Resistance Vs. Gate Voltage



**Fig 14a&b.** Basic Gate Charge Test Circuit and Waveform

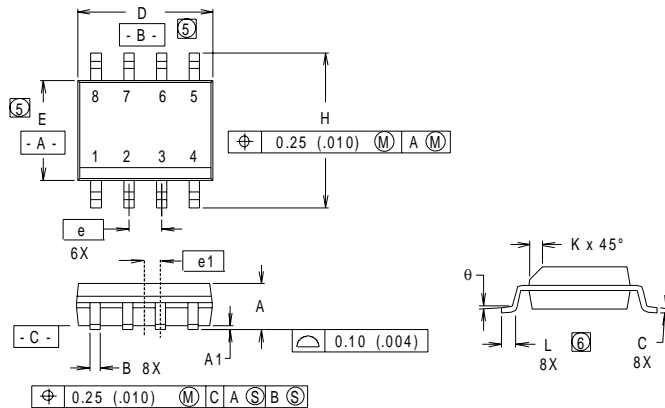


**Fig 15a&b.** Unclamped Inductive Test circuit and Waveforms



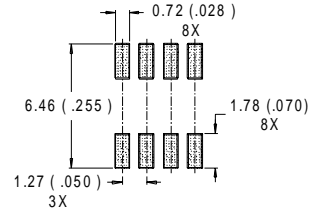
**Fig 15c.** Maximum Avalanche Energy Vs. Drain Current

## SO-8 Package Details



| DIM      | INCHES     |       | MILLIMETERS |      |
|----------|------------|-------|-------------|------|
|          | MIN        | MAX   | MIN         | MAX  |
| A        | .0532      | .0688 | 1.35        | 1.75 |
| A1       | .0040      | .0098 | 0.10        | 0.25 |
| B        | .014       | .018  | 0.36        | 0.46 |
| C        | .0075      | .0098 | 0.19        | 0.25 |
| D        | .189       | .196  | 4.80        | 4.98 |
| E        | .150       | .157  | 3.81        | 3.99 |
| e        | .050 BASIC |       | 1.27 BASIC  |      |
| e1       | .025 BASIC |       | 0.635 BASIC |      |
| H        | .2284      | .2440 | 5.80        | 6.20 |
| K        | .011       | .019  | 0.28        | 0.48 |
| L        | 0.16       | .050  | 0.41        | 1.27 |
| $\theta$ | 0°         | 8°    | 0°          | 8°   |

### RECOMMENDED FOOTPRINT

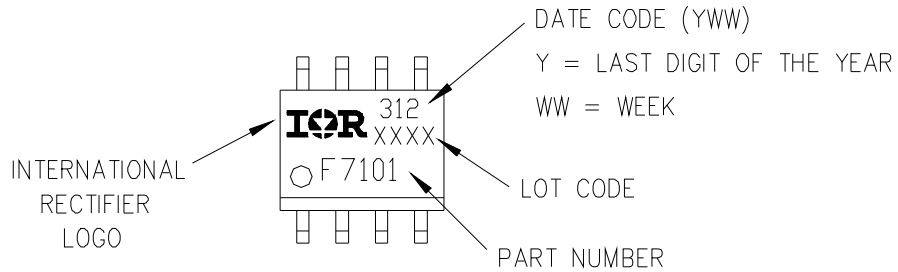


### NOTES:

1. DIMENSIONING AND TOLERANCING PER ANSI Y14.5M-1982.
2. CONTROLLING DIMENSION : INCH.
3. DIMENSIONS ARE SHOWN IN MILLIMETERS (INCHES).
4. OUTLINE CONFORMS TO JEDEC OUTLINE MS-012AA.
5. DIMENSION DOES NOT INCLUDE MOLD PROTRUSIONS  
MOLD PROTRUSIONS NOT TO EXCEED 0.25 (.006).
6. DIMENSIONS IS THE LENGTH OF LEAD FOR SOLDERING TO A SUBSTRATE..

## SO-8 Part Marking

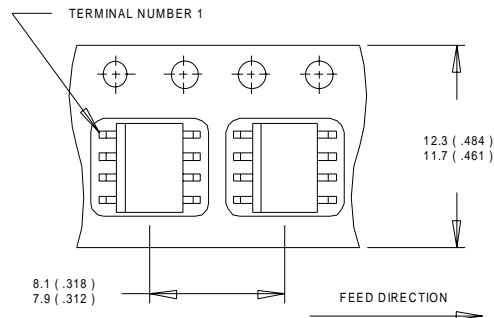
EXAMPLE: THIS IS AN IRF7101



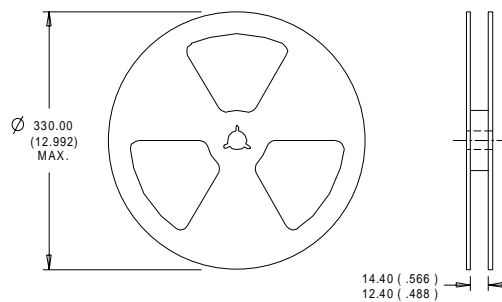
# IRF7477

International  
**IR** Rectifier

## SO-8 Tape and Reel



- NOTES:  
 1. CONTROLLING DIMENSION : MILLIMETER.  
 2. ALL DIMENSIONS ARE SHOWN IN MILLIMETERS(INCHES).  
 3. OUTLINE CONFORMS TO EIA-481 & EIA-541.



- NOTES:  
 1. CONTROLLING DIMENSION : MILLIMETER.  
 2. OUTLINE CONFORMS TO EIA-481 & EIA-541.

### Notes:

- ① Repetitive rating; pulse width limited by max. junction temperature.
- ② Starting  $T_J = 25^\circ\text{C}$ ,  $L = 15\text{mH}$   
 $R_G = 25\Omega$ ,  $I_{AS} = 8.2\text{A}$ .
- ③ Pulse width  $\leq 400\mu\text{s}$ ; duty cycle  $\leq 2\%$ .
- ④ When mounted on 1 inch square copper board

Data and specifications subject to change without notice.  
 This product has been designed and qualified for the Industrial market.  
 Qualification Standards can be found on IR's Web site.

International  
**IR** Rectifier

IR WORLD HEADQUARTERS: 233 Kansas St., El Segundo, California 90245, USA Tel: (310) 252-7105  
 TAC Fax: (310) 252-7903

Visit us at [www.irf.com](http://www.irf.com) for sales contact information. 6/01

[www.irf.com](http://www.irf.com)