

The RF MOSFET Line  
**RF Power Field Effect Transistors**  
 N-Channel Enhancement-Mode Lateral MOSFETs

**MRF9100**  
**MRF9100R3**  
**MRF9100SR3**

Designed for GSM and EDGE base station applications with frequencies from 921 to 960 MHz, the high gain and broadband performance of these devices make them ideal for large-signal, common source amplifier applications in 26 volt base station equipment.

- On-Die Integrated Input Match
- Typical Performance @ Full GSM Band, 921 to 960 MHz, 26 Volts  
 Output Power, P1dB — 110 Watts (Typ)  
 Power Gain @ P1dB — 16.5 dB (Typ)  
 Efficiency @ P1dB — 53% (Typ)
- Integrated ESD Protection
- Designed for Maximum Gain and Insertion Phase Flatness
- Capable of Handling 5:1 VSWR, @ 26 Vdc, 921 MHz, 100 Watts (CW) Output Power
- Excellent Thermal Stability
- Characterized with Series Equivalent Large-Signal Impedance Parameters
- Available in Tape and Reel. R3 Suffix = 250 Units per 56 mm, 13 inch Reel.

**GSM/EDGE 900 MHz, 110 W, 26 V**  
**LATERAL N-CHANNEL**  
**RF POWER MOSFETs**

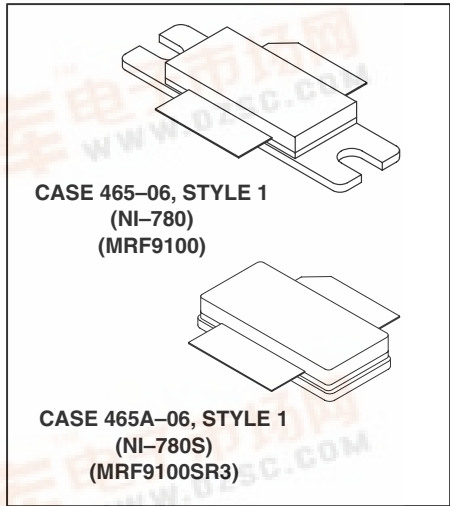

**MAXIMUM RATINGS**

Rating	Symbol	Value	Unit
Drain-Source Voltage	$V_{DSS}$	65	Vdc
Gate-Source Voltage	$V_{GS}$	+15, -0.5	Vdc
Total Device Dissipation @ $T_C = 25^\circ\text{C}$ Derate above $25^\circ\text{C}$	$P_D$	175 1.0	Watts W/ $^\circ\text{C}$
Storage Temperature Range	$T_{stg}$	-65 to +200	$^\circ\text{C}$
Operating Junction Temperature	$T_J$	200	$^\circ\text{C}$

**ESD PROTECTION CHARACTERISTICS**

Test Conditions	Class
Human Body Model	1 (Minimum)
Machine Model	M3 (Minimum)
Charge Device Model	C7 (Minimum)

**THERMAL CHARACTERISTICS**

Characteristic	Symbol	Max	Unit
Thermal Resistance, Junction to Case	$R_{\theta JC}$	1.0	$^\circ\text{C/W}$

NOTE - **CAUTION** - MOS devices are susceptible to damage from electrostatic charge. Reasonable precautions in handling and packaging MOS devices should be observed.



**ELECTRICAL CHARACTERISTICS** ( $T_C = 25^\circ\text{C}$ , 50 ohm system unless otherwise noted)

Characteristic	Symbol	Min	Typ	Max	Unit
----------------	--------	-----	-----	-----	------

**OFF CHARACTERISTICS**

Drain–Source Breakdown Voltage ( $V_{DS} = 65\text{ Vdc}$ , $V_{GS} = 0\text{ Vdc}$ )	$I_{DSS}$	—	—	10	$\mu\text{Adc}$
Zero Gate Voltage Drain Current ( $V_{DS} = 26\text{ Vdc}$ , $V_{GS} = 0\text{ Vdc}$ )	$I_{DSS}$	—	—	1	$\mu\text{Adc}$
Gate–Source Leakage Current ( $V_{GS} = 5\text{ Vdc}$ , $V_{DS} = 0\text{ Vdc}$ )	$I_{GSS}$	—	—	1	$\mu\text{Adc}$

**ON CHARACTERISTICS**

Gate Threshold Voltage ( $V_{DS} = 10\text{ Vdc}$ , $I_D = 500\ \mu\text{Adc}$ )	$V_{GS(th)}$	2	—	4	Vdc
Gate Quiescent Voltage ( $V_{DS} = 26\text{ Vdc}$ , $I_D = 800\text{ mAdc}$ )	$V_{GS(Q)}$	3	—	5	Vdc
Drain–Source On–Voltage ( $V_{GS} = 10\text{ Vdc}$ , $I_D = 2\text{ Adc}$ )	$V_{DS(on)}$	—	0.19	0.5	Vdc
Forward Transconductance ( $V_{DS} = 10\text{ Vdc}$ , $I_D = 2\text{ Adc}$ )	$g_{fs}$	—	8	—	S

**DYNAMIC CHARACTERISTICS (1)**

Reverse Transfer Capacitance ( $V_{DS} = 26\text{ Vdc} \pm 30\text{ mV(rms)ac}$ @ 1 MHz, $V_{GS} = 0\text{ Vdc}$ )	$C_{rss}$	—	1.0	—	pF
---	-----------	---	-----	---	----

**FUNCTIONAL TESTS** (In Motorola Test Fixture)

Output Power, 1 dB Compression Point, CW ( $V_{DD} = 26\text{ Vdc}$ , $I_{DQ} = 800\text{ mA}$ , $f = 960\text{ MHz}$ )	$P_{1dB}$	100	110	—	W
Common–Source Amplifier Power Gain ( $V_{DD} = 26\text{ Vdc}$ , $P_{out} = 100\text{ W CW}$ , $I_{DQ} = 800\text{ mA}$ , $f = 960\text{ MHz}$ )	$G_{ps}$	16	17	—	dB
Drain Efficiency ( $V_{DD} = 26\text{ Vdc}$ , $P_{out} = 100\text{ W CW}$ , $I_{DQ} = 800\text{ mA}$ , $f = 960\text{ MHz}$ )	$\eta$	47	51	—	%
Input Return Loss ( $V_{DD} = 26\text{ Vdc}$ , $P_{out} = 100\text{ W CW}$ , $I_{DQ} = 800\text{ mA}$ , $f_1 = 921\text{ MHz}$ and $960\text{ MHz}$ , $f_2 = 940\text{ MHz}$ )	IRL	—	—	–10	dB
Third Order Intermodulation Distortion ( $V_{DD} = 26\text{ Vdc}$ , $P_{out} = 100\text{ W PEP}$ , $I_{DQ} = 800\text{ mA}$ , $f = \text{Full GSM Band } 921\text{--}960\text{ MHz}$ , Tone Spacing = 100 kHz)	IMD	—	–30	—	dBc
Output Mismatch Stress ( $V_{DD} = 26\text{ Vdc}$ , $I_{DQ} = 800\text{ mA}$ , $P_{out} = 100\text{ W CW}$ , $f = 921\text{ MHz}$ , VSWR = 5:1, All Phase Angles at Frequency of Tests)	$\Psi$	No Degradation In Output Power Before and After Test			

(1) Part is internally matched both on input and output.

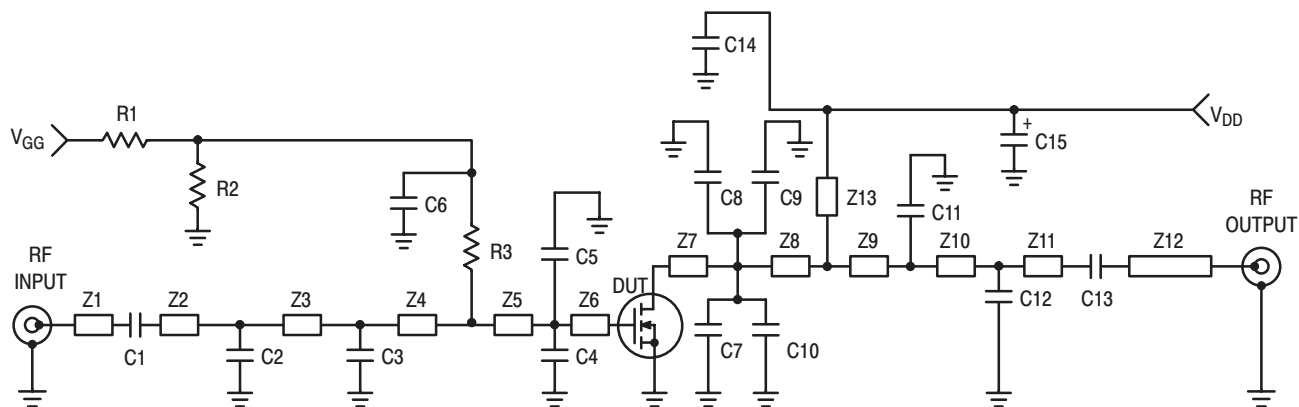

Figure 1. MRF9100 Test Circuit Schematic

Table 1. MRF9100 Test Circuit Component Designations and Values

Designators	Description
C1, C13	22 pF, 100B Chip Capacitors, ATC #100B220GW
C2, C12	2.2 pF, 100B Chip Capacitors, ATC #100B2R2BW
C3	6.8 pF, 100B Chip Capacitor, ATC #100B6R8CW
C4, C5	10 pF, 100B Chip Capacitors, ATC #100B100GW
C6, C14	33 pF, 100B Chip Capacitors, ATC #100B330JW
C7, C8, C9, C10	4.7 pF, 100B Chip Capacitors, ATC #100B4R7BW
C11	2.7 pF, 100B Chip Capacitor, ATC #100B2R7BW
C15	10 $\mu$ F, 35 V Tantalum Chip Capacitor, Vishay–Sprague #293D106X9035D
R1, R2	10 k $\Omega$ , 1/8 W Chip Resistors (0805)
R3	1 k $\Omega$ , 1/8 W Chip Resistor (0805)
Z1	0.495" x 0.087" Microstrip
Z2	0.657" x 0.087" Microstrip
Z3	0.324" x 0.087" Microstrip
Z4	0.429" x 0.087" Microstrip
Z5	0.250" x 0.790" Microstrip
Z6	0.535" x 0.790" Microstrip
Z7	0.312" x 0.790" Microstrip
Z8	0.409" x 0.790" Microstrip
Z9	0.432" x 0.087" Microstrip
Z10	0.220" x 0.087" Microstrip
Z11	0.828" x 0.087" Microstrip
Z12	0.485" x 0.087" Microstrip
Z13	1.602" x 0.087" Microstrip
Substrate	Taconic TLX8, Thickness 0.8 mm

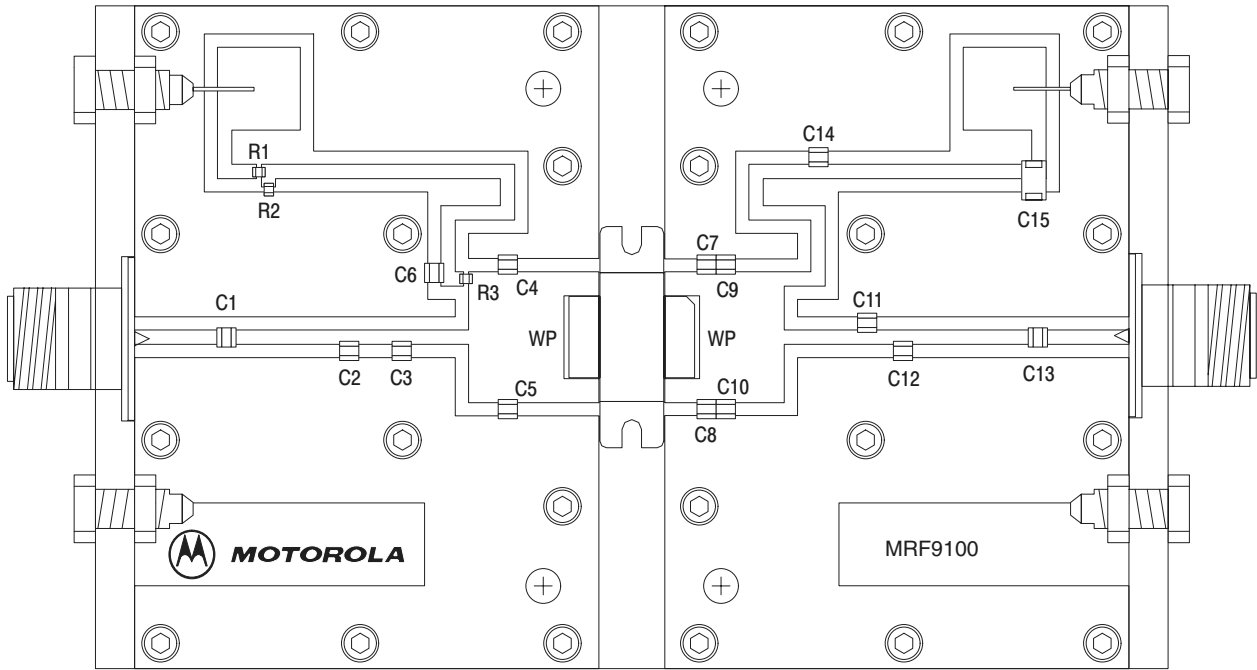

Figure 2. MRF9100 Test Circuit Component Layout

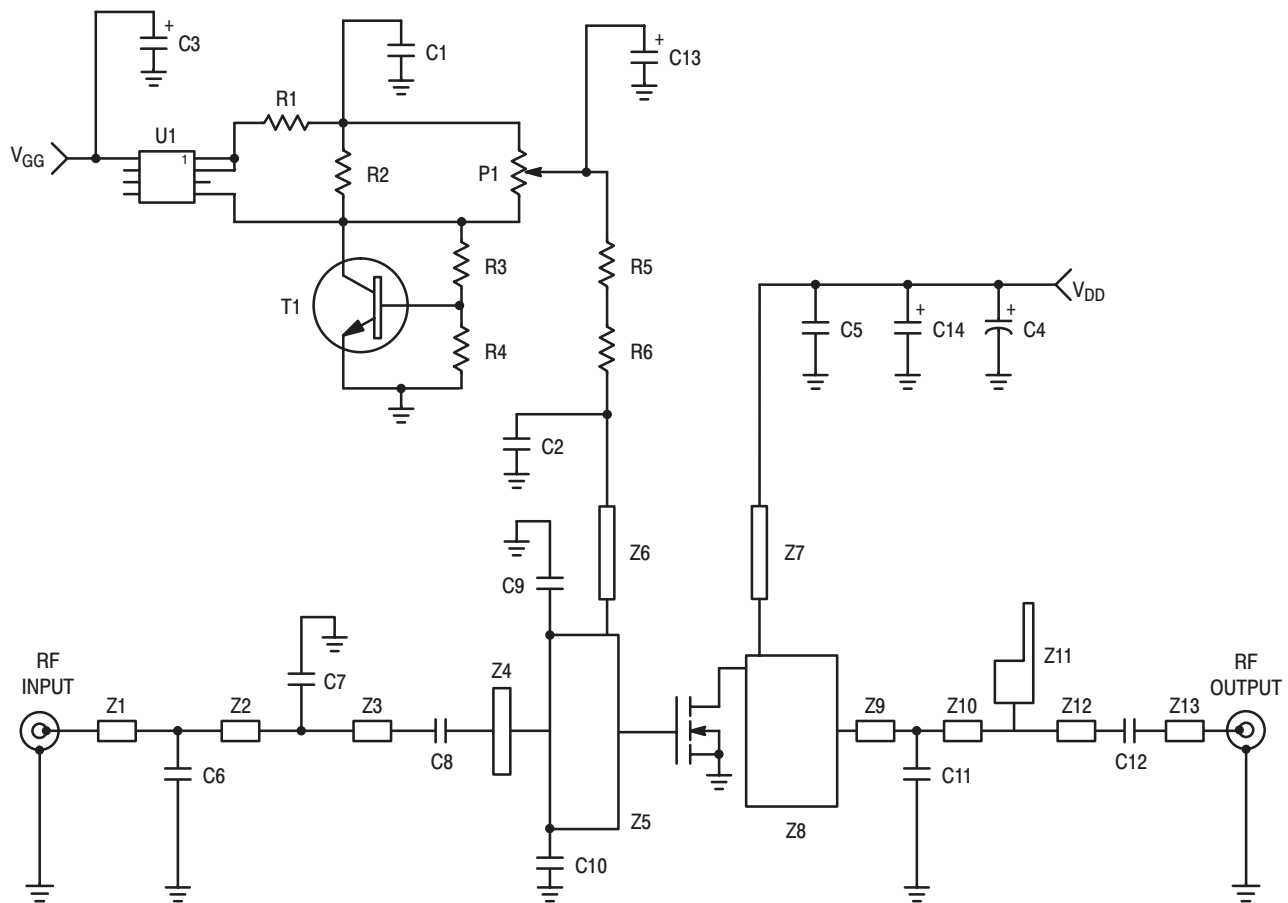

Figure 3. MRF9100 Demo Board Schematic

**Table 2. GSM 900 Optimized Demo Board Component Designations and Values**

Designators	Description
C1	1.0 $\mu$ F Chip Capacitor, AVX #08053G105ZATEA (0805)
C2, C5	33 pF Chip Capacitors, AVX #08051J330GBT, ACCU-P (0805)
C3, C13, C14	22 $\mu$ F, 35 V Tantalum Chip Capacitors, Kemet #T491x226K035AS4394
C4	220 $\mu$ F, 63 V Electrolytic Capacitor Radial, Philips #13668221
C6	5.6 pF Chip Capacitor, AVX #08051J5R6CBT, ACCU-P (0805)
C7	4.7 pF Chip Capacitor, AVX #08051J4R7CBT, ACCU-P (0805)
C8	22 pF Chip Capacitor, AVX #08051J220GBT, ACCU-P (0805)
C9, C10	3.9 pF Chip Capacitors, AVX #08051J3R9BBT, ACCU-P (0805)
C11	2.2 pF Chip Capacitor, AVX #08051J2R2BBT, ACCU-P (0805)
C12	33 pF, 100B Chip Capacitor, ATC #100B330JW
P1	5.0 k $\Omega$ Potentiometer CMS Cermet multi-turn, Bourns #3224W
R1	10 $\Omega$ , 1/8 W Chip Resistor (0805)
R2	1.0 k $\Omega$ , 1/8 W Chip Resistor (0805)
R3	1.2 k $\Omega$ , 1/8 W Chip Resistor (0805)
R4	2.2 k $\Omega$ , 1/8 W Chip Resistor (0805)
R5	100 $\Omega$ , 1/8 W Chip Resistor (0805)
R6	1.0 $\Omega$ , 1/8 W Chip Resistor (0805)
T1	NPN Bipolar Transistor, SOT-23, Motorola #BC847
U1	Voltage Regulator, Micro-8, Motorola #LP2951
Z1	0.916" x 0.042" Microstrip
Z2	0.169" x 0.042" Microstrip
Z3	0.212" x 0.042" Microstrip
Z4	0.090" x 0.465" Microstrip
Z5	0.465" x 0.842" Microstrip
Z6	1.776" x 0.059" Microstrip
Z7	1.802" x 0.059" Microstrip
Z8	1.094" x 0.592" Microstrip
Z9	0.085" x 0.042" Microstrip
Z10	0.198" x 0.042" Microstrip
Z11	0.253" x 0.191" + 0.292" x 0.061" Microstrip
Z12	0.181" x 0.042" Microstrip
Z13	0.282" x 0.042" Microstrip
Substrate	Taconic RF35, Thickness 0.5 mm, $\epsilon_r = 3.5$

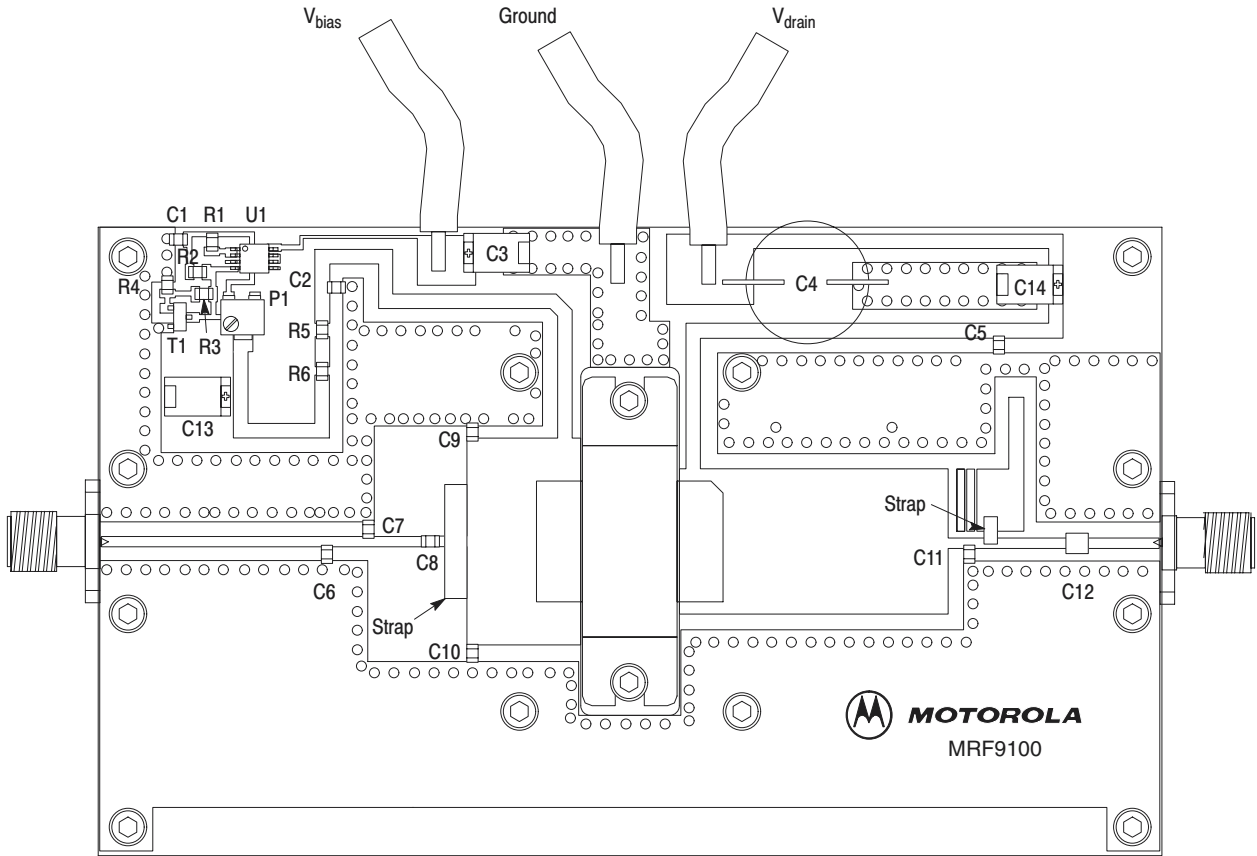

Figure 4. MRF9100 Demo Board Component Layout

## TYPICAL CHARACTERISTICS

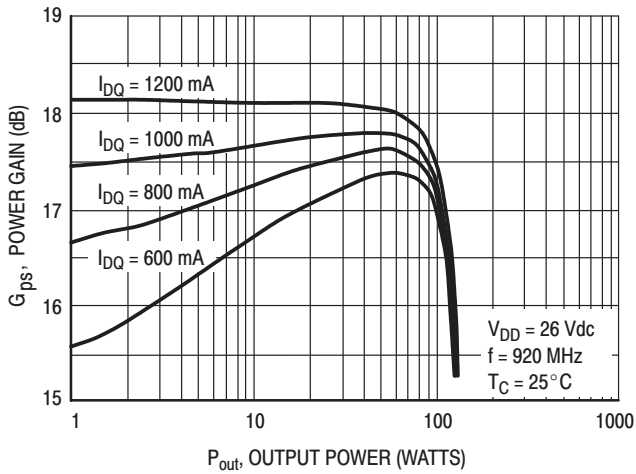

Figure 5. Power Gain versus Output Power

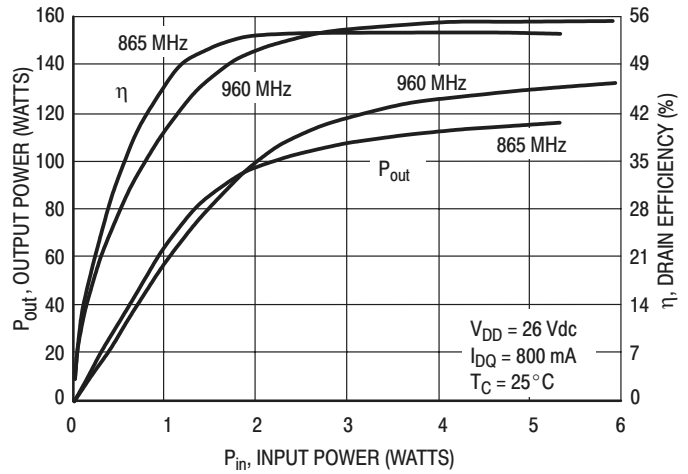

Figure 6. Output Power and Efficiency versus Input Power

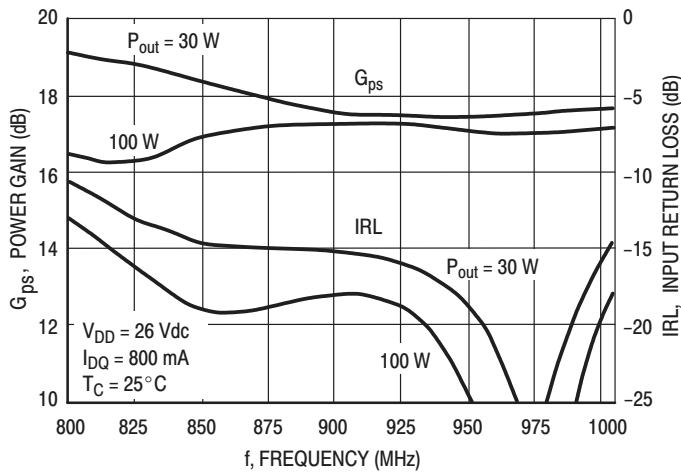

Figure 7. Power Gain and Input Return Loss versus Frequency

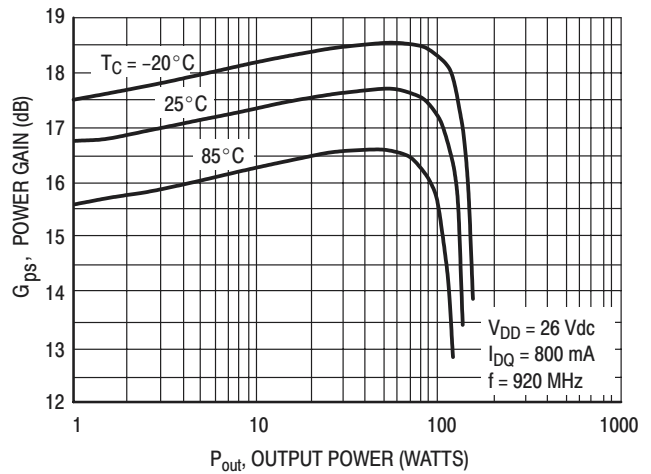

Figure 8. Power Gain versus Output Power

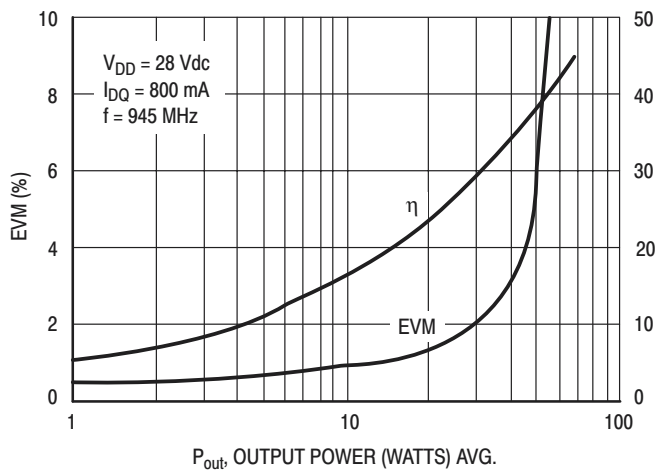

Figure 9. EVM and Efficiency versus Output Power

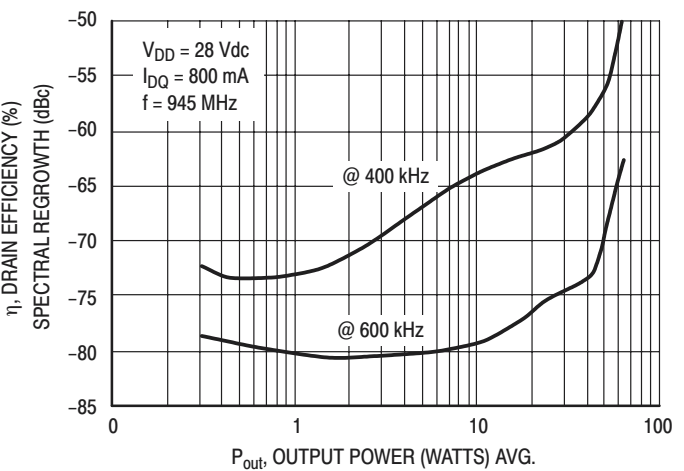
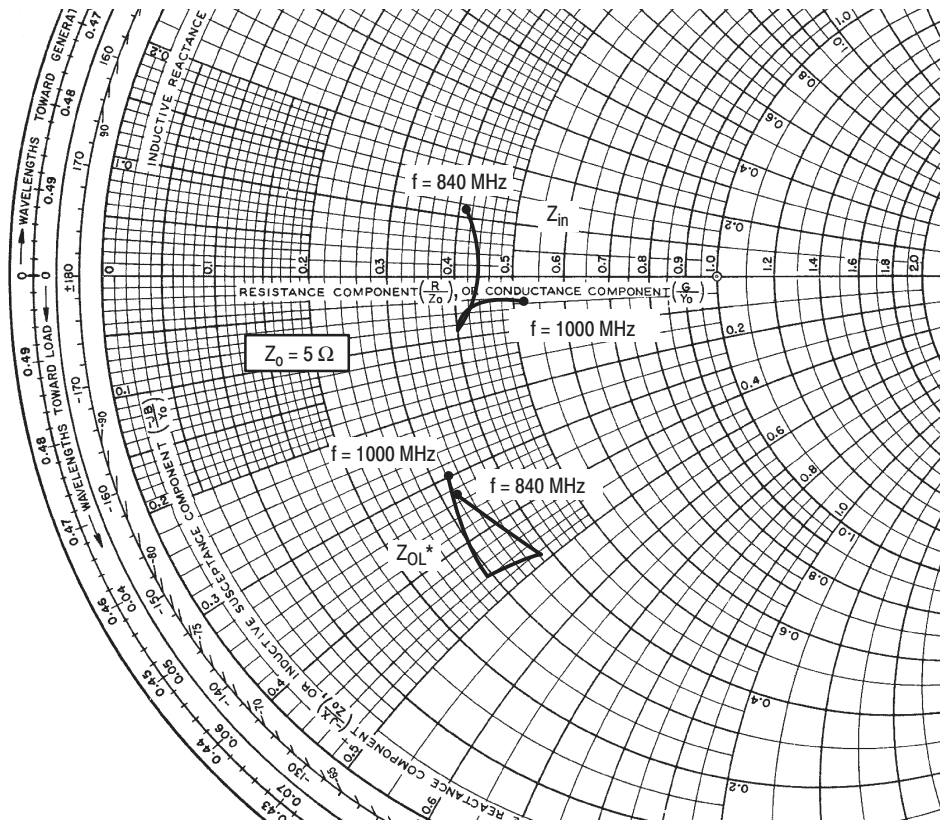

Figure 10. Spectral Regrowth versus Output Power





$V_{DD} = 26 \text{ V}$ ,  $I_{DQ} = 800 \text{ mA}$ ,  $P_{out} = 110 \text{ W (CW)}$

f MHz	$Z_{in}$ $\Omega$	$Z_{OL}^*$ $\Omega$
840	$2.04 + j0.57$	$1.62 - j1.65$
880	$2.20 + j0.16$	$1.88 - j2.45$
920	$2.00 - j0.44$	$1.79 - j2.40$
960	$2.16 - j0.25$	$1.47 - j1.82$
1000	$2.62 - j0.25$	$1.58 - j1.52$

$Z_{in}$  = Complex conjugate of source impedance.

$Z_{OL}^*$  = Complex conjugate of the optimum load impedance at a given output power, voltage, IMD, bias current and frequency.

Note:  $Z_{OL}^*$  was chosen based on tradeoffs between gain, output power, drain efficiency and intermodulation distortion.

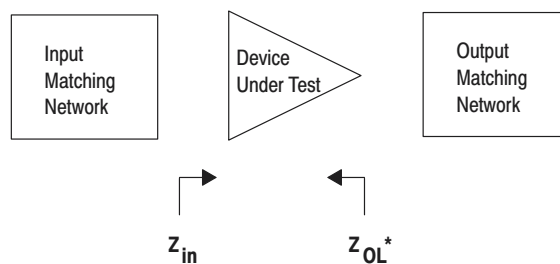
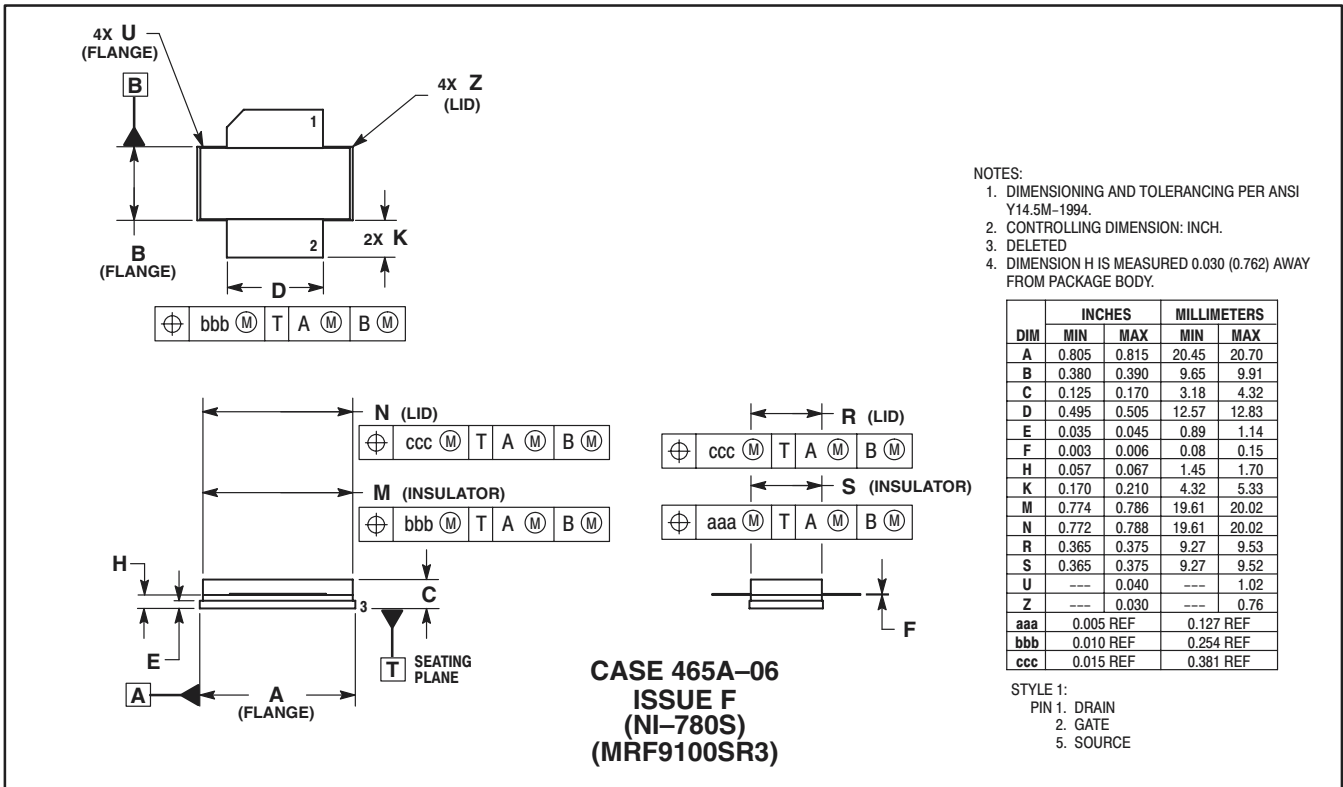
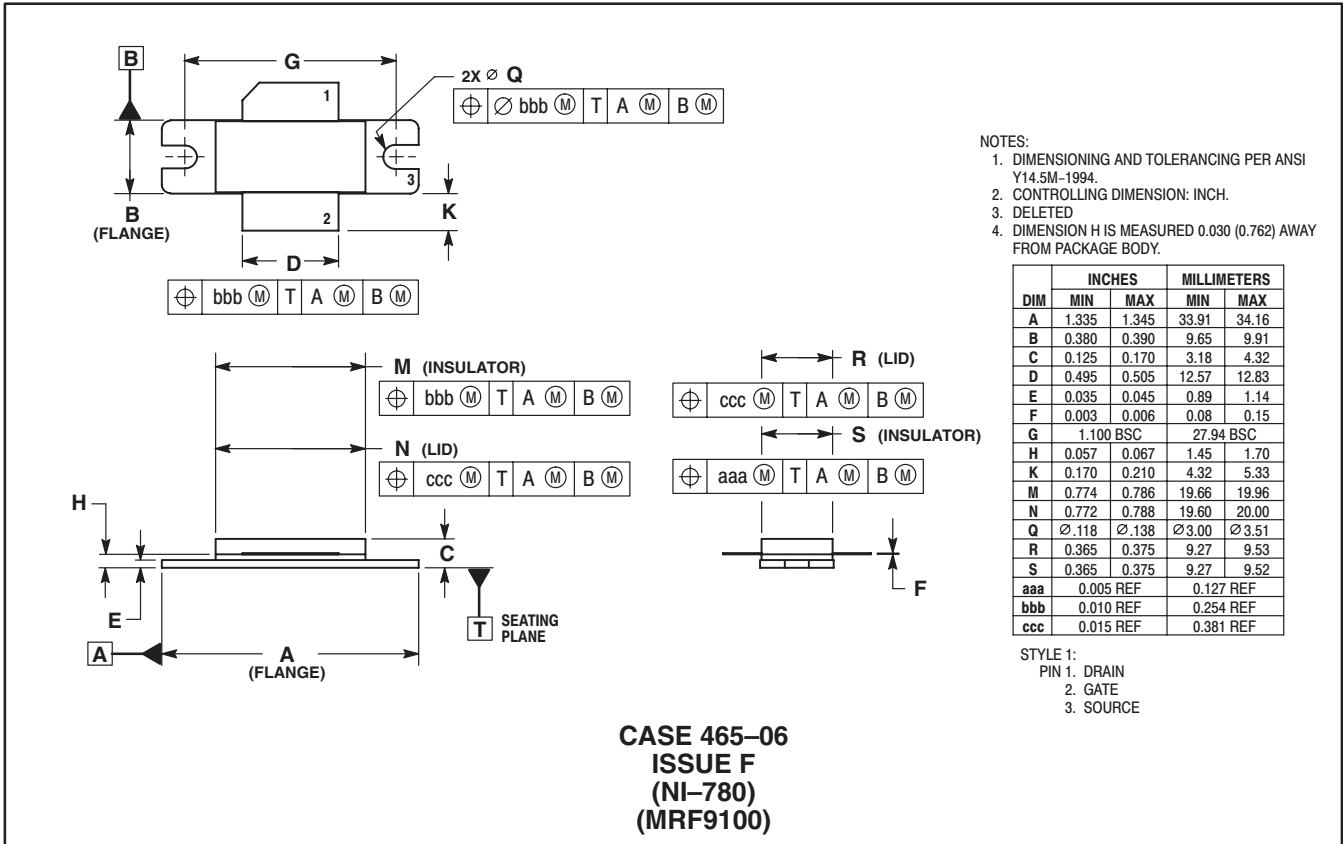



Figure 11. Series Equivalent Input and Output Impedance

# NOTES

## PACKAGE DIMENSIONS



Motorola reserves the right to make changes without further notice to any products herein. Motorola makes no warranty, representation or guarantee regarding the suitability of its products for any particular purpose, nor does Motorola assume any liability arising out of the application or use of any product or circuit, and specifically disclaims any and all liability, including without limitation consequential or incidental damages. "Typical" parameters which may be provided in Motorola data sheets and/or specifications can and do vary in different applications and actual performance may vary over time. All operating parameters, including "Typicals" must be validated for each customer application by customer's technical experts. Motorola does not convey any license under its patent rights nor the rights of others. Motorola products are not designed, intended, or authorized for use as components in systems intended for surgical implant into the body, or other applications intended to support or sustain life, or for any other application in which the failure of the Motorola product could create a situation where personal injury or death may occur. Should Buyer purchase or use Motorola products for any such unintended or unauthorized application, Buyer shall indemnify and hold Motorola and its officers, employees, subsidiaries, affiliates, and distributors harmless against all claims, costs, damages, and expenses, and reasonable attorney fees arising out of, directly or indirectly, any claim of personal injury or death associated with such unintended or unauthorized use, even if such claim alleges that Motorola was negligent regarding the design or manufacture of the part. Motorola, Inc. Motorola, Inc. is an Equal Opportunity/Affirmative Action Employer. MOTOROLA and the  logo are registered in the US Patent & Trademark Office. All other product or service names are the property of their respective owners.

© Motorola, Inc. 2002.

**How to reach us:**

**USA/EUROPE/Locations Not Listed:** Motorola Literature Distribution; P.O. Box 5405, Denver, Colorado 80217. 1-303-675-2140 or 1-800-441-2447

**JAPAN:** Motorola Japan Ltd.; SPS, Technical Information Center, 3-20-1, Minami-Azabu. Minato-ku, Tokyo 106-8573 Japan. 81-3-3440-3569

**ASIA/PACIFIC:** Motorola Semiconductors H.K. Ltd.; Silicon Harbour Centre, 2 Dai King Street, Tai Po Industrial Estate, Tai Po, N.T., Hong Kong. 852-26668334

**Technical Information Center: 1-800-521-6274**

**HOME PAGE:** <http://www.motorola.com/semiconductors/>

