



# ACTS245MS

## Radiation Hardened Octal Non-Inverting Bidirectional Bus Transceiver

January 1996

### Features

- Devices QML Qualified in Accordance with MIL-PRF-38535
- Detailed Electrical and Screening Requirements are Contained in SMD# 5962-96719 and Intersil' QM Plan
- 1.25 Micron Radiation Hardened SOS CMOS
- Total Dose ..... >300K RAD (Si)
- Single Event Upset (SEU) Immunity: <math> < 1 \times 10^{-10}</math> Errors/Bit/Day (Typ)
- SEU LET Threshold ..... >100 MEV-cm<sup>2</sup>/mg
- Dose Rate Upset ..... >10<sup>11</sup> RAD (Si)/s, 20ns Pulse
- Dose Rate Survivability ..... >10<sup>12</sup> RAD (Si)/s, 20ns Pulse
- Latch-Up Free Under Any Conditions
- Military Temperature Range ..... -55°C to +125°C
- Significant Power Reduction Compared to ALSTTL Logic
- DC Operating Voltage Range ..... 4.5V to 5.5V
- Input Logic Levels
  - VIL = 0.8V Max
  - VIH = VCC/2 Min
- Input Current ≤ 1μA at VOL, VOH
- Fast Propagation Delay ..... 18ns (Max), 12ns (Typ)

### Description

The Intersil ACTS245MS is a Radiation Hardened octal non-inverting bidirectional bus transceiver intended for two-way asynchronous communication between data busses.

The ACTS245MS utilizes advanced CMOS/SOS technology to achieve high-speed operation. This device is a member of a radiation hardened, high-speed, CMOS/SOS Logic Family.

The ACTS245MS is supplied in a 20 lead Ceramic Flatpack (K suffix) or a Dual-In-Line Ceramic Package (D suffix).

### Pinouts

20 PIN CERAMIC DUAL-IN-LINE, MIL-STD-1835 DESIGNATOR CDIP2-T20, LEAD FINISH C TOP VIEW

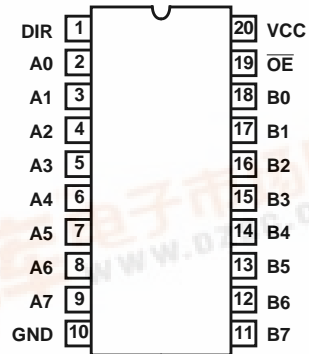

20 PIN CERAMIC FLATPACK, MIL-STD-1835 DESIGNATOR CDFP4-F20, LEAD FINISH C TOP VIEW

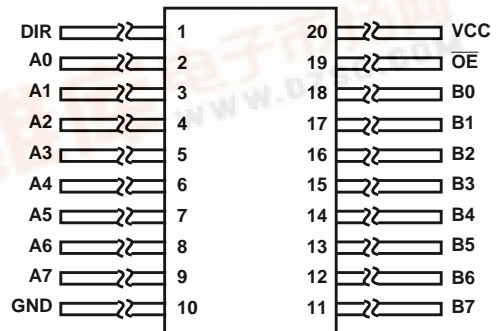

### Ordering Information

PART NUMBER	TEMPERATURE RANGE	SCREENING LEVEL	PACKAGE
5962F9671901VRC	-55°C to +125°C	MIL-PRF-38535 Class V	20 Lead SBDIP
5962F9671901VXC	-55°C to +125°C	MIL-PRF-38535 Class V	20 Lead Ceramic Flatpack
ACTS245D/Sample	25°C	Sample	20 Lead SBDIP
ACTS245K/Sample	25°C	Sample	20 Lead Ceramic Flatpack
ACTS245MSR	25°C	Die	Die

## ACTS245MS

### Functional Diagram

NOTE: (1 of 8)

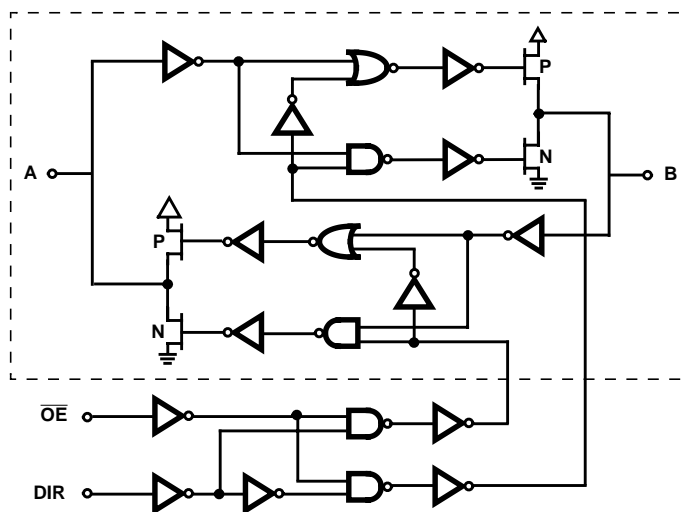

TRUTH TABLE

INPUTS		OPERATION
$\overline{OE}$	DIR	
L	L	B Data to A Bus
L	H	A Data to B Bus
H	X	Isolation

NOTE:

H = High Voltage Level, L = Low Voltage Level, X = Immaterial

All Intersil semiconductor products are manufactured, assembled and tested under **ISO9000** quality systems certification.

*Intersil products are sold by description only. Intersil Corporation reserves the right to make changes in circuit design and/or specifications at any time without notice. Accordingly, the reader is cautioned to verify that data sheets are current before placing orders. Information furnished by Intersil is believed to be accurate and reliable. However, no responsibility is assumed by Intersil or its subsidiaries for its use; nor for any infringements of patents or other rights of third parties which may result from its use. No license is granted by implication or otherwise under any patent or patent rights of Intersil or its subsidiaries.*

For information regarding Intersil Corporation and its products, see web site <http://www.intersil.com>

# ACTS245MS

## Die Characteristics

### DIE DIMENSIONS:

96 mils x 117 mils  
2.44 x 2.97 mm

### METALLIZATION:

Type: AlSi  
Metal 1 Thickness:  $7.125\text{k}\text{\AA} \pm 1.125\text{k}\text{\AA}$   
Metal 2 Thickness:  $9\text{k}\text{\AA} \pm 1\text{k}\text{\AA}$

### GLASSIVATION:

Type:  $\text{SiO}_2$   
Thickness:  $8\text{k}\text{\AA} \pm 1\text{k}\text{\AA}$

### WORST CASE CURRENT DENSITY:

$<2.0 \times 10^5 \text{A/cm}^2$

### BOND PAD SIZE:

$110\mu\text{m} \times 110\mu\text{m}$   
4.4 mils x 4.4 mils

## Metallization Mask Layout

