



SPECIFICATION

Device Name : Current Mode PWM Controller

Type Name : FA13844N

Spec. No. : MS6N0362

This material and the information herein is the property of Fuji Electric Co., Ltd. They shall be neither reproduced, copied, lent, or disclosed in any way whatsoever for the use of any third party, nor used for the manufacturing purposes without the express written consent of Fuji Electric Co., Ltd.

Fuji Electric Co., Ltd.
Matsumoto Factory

	DATE	NAME	APPROVED	Fuji Electric Co., Ltd.	
	DRAWN	Feb-11-'98	H. Maruyama	M. Saito	MS6N0362
CHECKED	Feb-11-'98	H. Saito	1/17		

Revised Records

Date	Classification	Ind.	Content	Applied Date	Drawn	Checked	Approved
FEB-11 -1998	Enactment	—	—	FEB-11 -1998	H. Maruyama	M. Saito	H. Saito

This material and the information herein is the property of Fuji Electric Co., Ltd. They shall be neither reproduced, copied, lent, or disclosed in any way whatsoever for the use of any third party, nor used for the manufacturing purposes without the express written consent of Fuji Electric Co., Ltd.

This material and the information herein is the property of Fuji Electric Co., Ltd. They shall be neither reproduced, copied, lent, or disclosed in any way whatsoever for the use of any third party, nor used for the manufacturing purposes without the express written consent of Fuji Electric Co., Ltd.

	Page
1. Type Name	4/17
2. Function	4/17
3. Process	4/17
4. Outline	4/17
5. Block Diagram	4/17
6. Pin Assignment	4/17
7. Absolute Maximum Ratings	5/17
8. Recommended Operating Conditions	5/17
9. Electrical Specifications	6~7/17
10. Reliability	8/17
11. Outline Diagram	9/17
12. Inner Structure	10/17
13. Embossed Carrier Tape Specifications (Packing Specification)	11~17/17

1. Type Name FA13844N
2. Function Current Mode PWM Controller
3. Process CMOS IC
4. Outline SOP-8(8pin plastic mold small out-line package)
5. Block Diagram

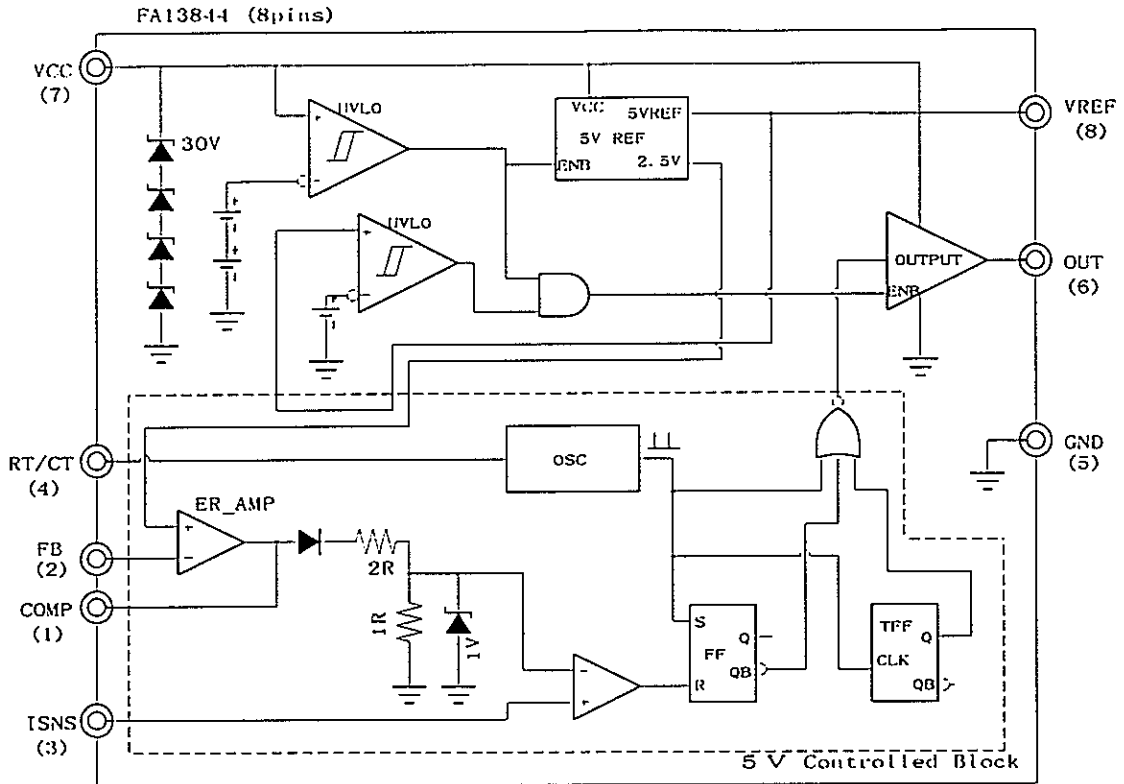

6. Pin Assignment

Pin No.	Pin Name	Pin Function
1	COMP	Compensation
2	FB	Feedback (Input)
3	ISNS	Current Sense (Input)
4	RT/CT	Oscillator control
5	GND	Ground
6	OUT	Output
7	VCC	Power Supply
8	VREF	5V Reference Output

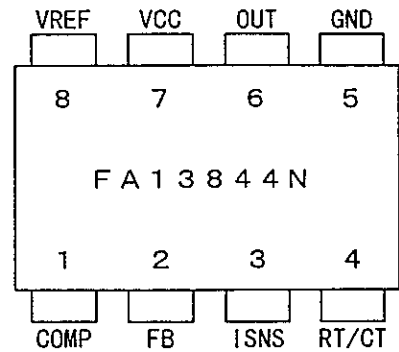

This material and the information herein is the property of Fuji Electric Co., Ltd. They shall be neither reproduced, copied, lent, or disclosed in any way whatsoever for the use of any third party, nor used for the manufacturing purposes without the express written consent of Fuji Electric Co., Ltd.

7. ABSOLUTE MAXIMUM RATINGS

Parameter	Conditions	Ratings	Units
Supply Voltage	Low Impedance Source	28	V
	Zener Clamp (at $I_{CC} < 10\text{mA}$)	Self Limiting	V
Zener Current		10	mA
Output Peak Current	Pch Source Current	400	mA
	Nch Sink Current	1	A
Analog Input Voltage	FB,ISNS	-0.3 ~ 5.3	V
Error-amp Sink Current		10	mA
Power Dissipation	at $T_a < 50^\circ\text{C}$ (SOP-8)	400	mW
Package Thermal Resistance θ_{j-a}	between junction and Ambient	250	$^\circ\text{C}/\text{W}$
Operating Junction Temperature		150	$^\circ\text{C}$
Operating Ambient Temperature		-25 ~ 85	$^\circ\text{C}$
Storage Temperature		-40 ~ 150	$^\circ\text{C}$

8. RECOMMENDED OPERATING CONDITIONS

Parameter	MIN.	MAX.	Units
Supply Voltage	10	25	V
RT Resistor	2.0	100	k Ω
CT Capacitor	0.47	10	nF
Operating Frequency	10	500	kHz

This material and the information herein is the property of Fuji Electric Co., Ltd. They shall be neither reproduced, copied, lent, or disclosed in any way whatsoever for the use of any third party, nor used for the manufacturing purposes without the express written consent of Fuji Electric Co., Ltd.

9. ELECTRICAL SPECIFICATIONS

(Unless otherwise standard, these specifications apply for VCC=15V, RT=10k, CT=3.3nF, Ta=25°C)

Reference Section

Parameter	Conditions	MIN.	TYP.	MAX.	Units
Output Voltage	Tj=25°C, IL=1mA	4.75	5.00	5.25	V
Line Regulation	VCC=10~25V		±3	±20	mV
Load Regulation	IL=0~20mA		±3	±25	mV
Temp. Stability	Ta=-25~85°C		±0.3		mV/°C
Output Short Current	Tj=25°C		60		mA

Oscillator Section

Parameter	Conditions	MIN.	TYP.	MAX.	Units
Frequency	Tj=25°C	49	52	55	kHz
	Tj=-25~85°C	47		57	kHz
Voltage Stability	VCC=10~25V		±0.25	±1	%
Temp. Stability	Ta=-25~85°C		-0.07		%/°C
Amplitude	Tj=25°C		1.6		V
Discharge Current	Tj=25°C		8.4		mA

Error Amp Section

Parameter	Conditions	MIN.	TYP.	MAX.	Units
Input Voltage	COMP=2.5V, Tj=25°C	2.4	2.5	2.6	V
Input Leak Current				±2	uA
Open-loop Gain		65	72		dB
Unity Gain Bandwidth		0.7	1		MHz
Output Source Current	FB=2.3V, COMP=0V	-0.8	-1.0		mA
Output Sink Current	FB=2.7V, COMP=1V	2	15		mA
Output Voltage	FB=2.3V RL=15k to GND	4.0	4.5		V
	FB=2.7V RL=15k to VREF		80	500	mV

Current Sense Section

Parameter	Conditions	MIN.	TYP.	MAX.	Units
Gain	Tj=25°C	2.85	3	3.15	V/V
Maximum Input Signal	FB=0V	0.9	1.0	1.1	V
Input Bias Current			-1	-5	uA
Delay to Output	Tj=25°C, ISNS→OUT		150	300	ns

This material and the information herein is the property of Fuji Electric Co., Ltd. They shall be neither reproduced, copied, lent, or disclosed in any way whatsoever for the use of any third party, nor used for the manufacturing purposes without the express written consent of Fuji Electric Co., Ltd.

This material and the information herein is the property of Fuji Electric Co., Ltd. They shall be neither reproduced, copied, lent, or disclosed in any way whatsoever for the use of any third party, nor used for the manufacturing purposes without the express written consent of Fuji Electric Co., Ltd.

Output Section

Parameter	Conditions	MIN.	TYP.	MAX.	Units
Output High Level	I _{source} =-20mA	14.5	14.75		V
	I _{source} =-100mA	12	13.5		V
Output Low Level	I _{sink} =20mA		0.15	0.3	V
	I _{sink} =200mA		1.5	3	V
Rise Time	CL=1nF, T _j =25°C		40	150	ns
Fall Time	CL=1nF, T _j =25°C		20	150	ns

Under-Voltage Lockout Section

Parameter	Conditions	MIN.	TYP.	MAX.	Units
Start Threshold		15.5	16.5	17.5	V
Min. Operating Voltage		8	9	10	V
Hysteresis			7.5		V

PWM Section

Parameter	Conditions	MIN.	TYP.	MAX.	Units
Maximum Duty Cycle		47	48	50	%
Minimum Duty Cycle	FB=5V, COMP=open			0	%

Overall Section

Parameter	Conditions	MIN.	TYP.	MAX.	Units
Standby Current	VCC=14V			2	uA
Start-up Current	VCC=Start Threshold		12	30	uA
Operating Current			3	5	mA
Zener Voltage (VCC)	ICC=5mA	28	30	34	V

10. Reliability

No	Test Item	Testing Conditions	Measurement	Sampling number (Acceptance number)
1	Operating Life under High Temperature	85°C, VCC=28V 1000Hr	Electrical	22 (0:1)
2	Operating Life under High Temperature & Humidity	85°C, 85%RH, VCC=28V 1000Hr	Electrical	22 (0:1)
3	High Temperature Storage	150°C 1000Hr	Electrical	22 (0:1)
4	Low Temperature Storage	-40°C 1000Hr	Electrical	22 (0:1)
5	Temperature Cycle	-40°C(30min.)~150°C(30min.) 100cycle	Electrical	22 (0:1)
6	Unsaturated Pressurized Vapor (USPCT)	130±5°C, 85%RH, 2.3 × 10 ⁵ Pa 100Hr	Electrical	22 (0:1)
7	Resistance to Soldering Heat	260±5°C 5±1sec	Electrical Visual	22 (0:1)
8	Electrostatic Discharges (ESD)	1.5k Ω, 100pF, ±2000V 3 times	ESD tester	11 (0:1)
9	Latch up	0 Ω, 200pF, ±100V 3 times	Latch up tester	11 (0:1)
10	Solderability	260±5°C, 2±0.5sec using flux	Visual	11 (0:1)
11	Terminal Strength	Pull 0.1kgf 10±1sec	Visual	11 (0:1)
12	Drop	on the wooden board Height=75cm, 3 times	Visual	11 (0:1)
13	Permanence of Marking	Isopropyl alcohol 20~25°C, 30±5sec	Visual	11 (0:1)

This material and the information herein is the property of Fuji Electric Co., Ltd. They shall be neither reproduced, copied, lent, or disclosed in any way whatsoever for the use of any third party, nor used for the manufacturing purposes without the express written consent of Fuji Electric Co., Ltd.

11. Outline Diagram (SOP-8 pins)

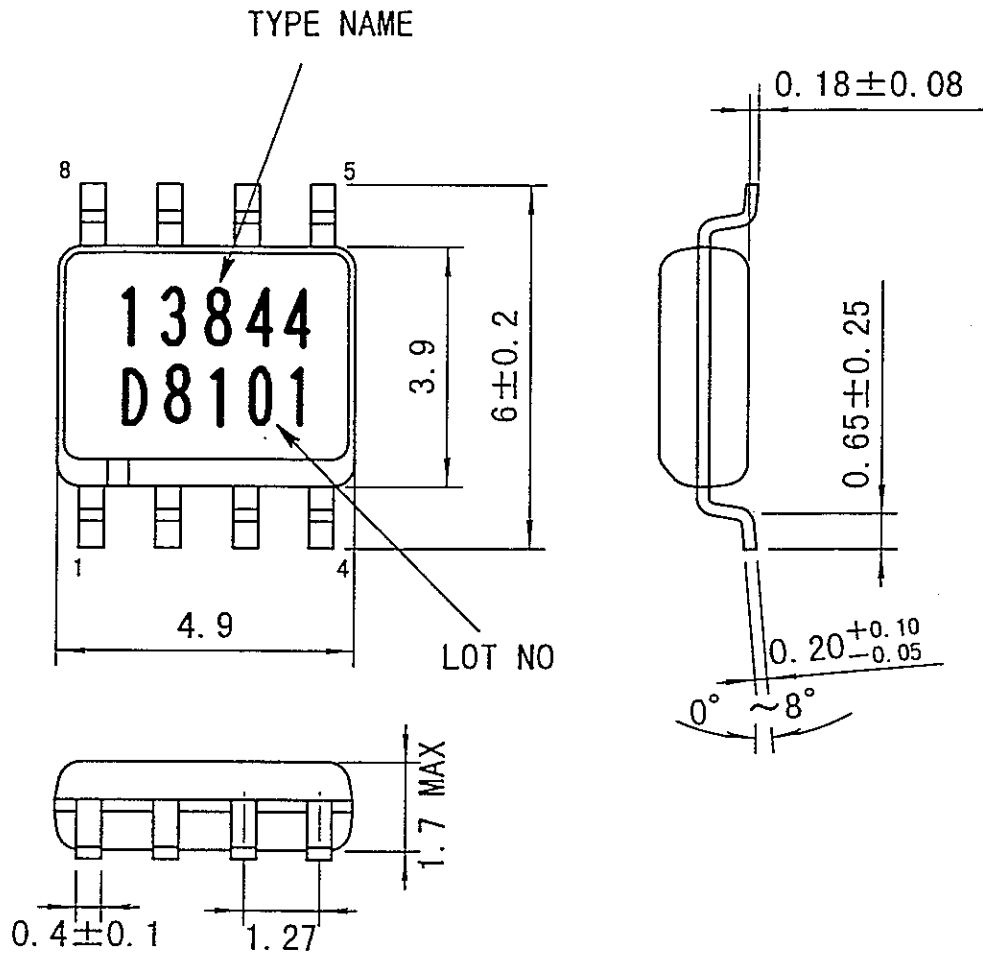

This material and the information herein is the property of Fuji Electric Co., Ltd. They shall be neither reproduced, copied, lent, or disclosed in any way whatsoever for the use of any third party, nor used for the manufacturing purposes without the express written consent of Fuji Electric Co., Ltd.

Contents of Lot No.

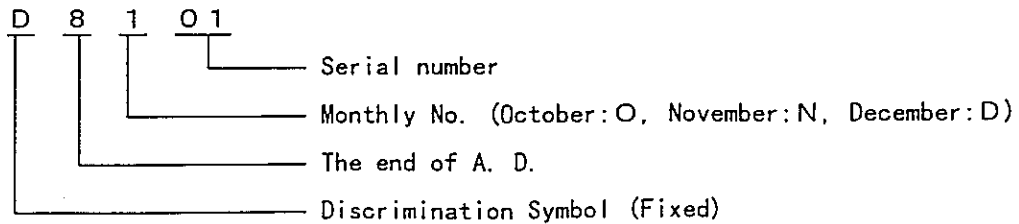

12. Inner Structure

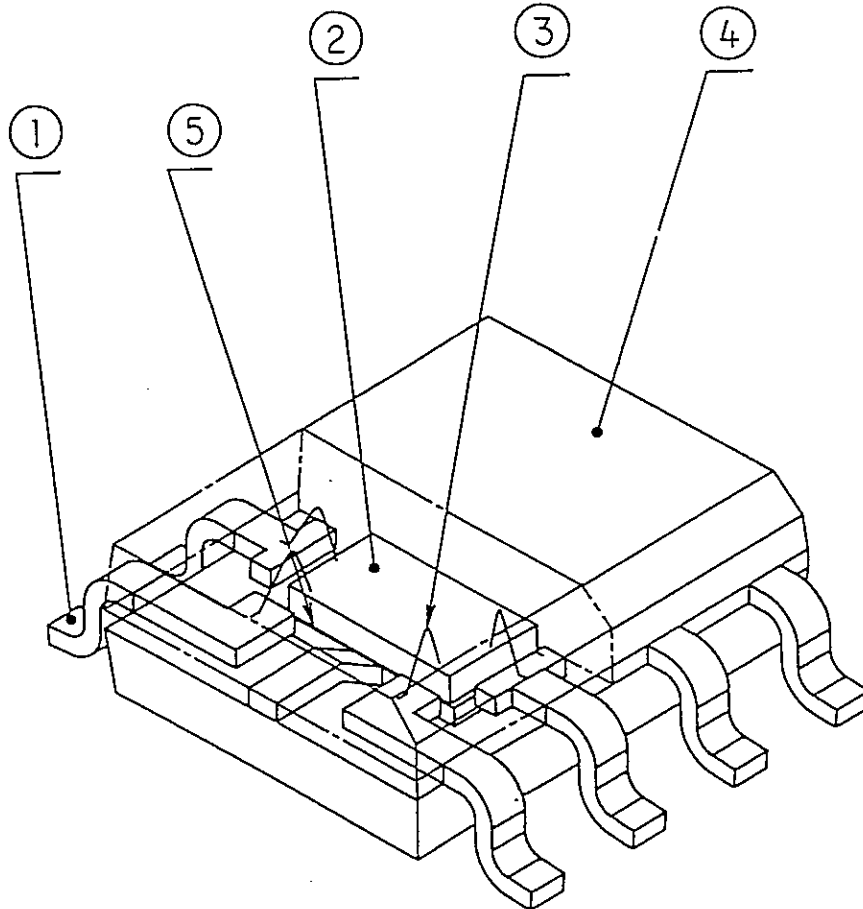

Ref.	Name	Material
①	Lead-frame	Copper
②	Chip	Silicon
③	Wire	Au ϕ 25 μ m
④	Resin	Epoxy Resin (UL94V-0)
⑤	Adhesive	Conductive Adhesive

This material and the information herein is the property of Fuji Electric Co., Ltd. They shall be neither reproduced, copied, lent, or disclosed in any way whatsoever for the use of any third party, nor used for the manufacturing purposes without the express written consent of Fuji Electric Co., Ltd.

13. Embossed Carrier Tape Specification

(1) Description

This specification defines the method of taping SOP-8pin for packing delivery.

And this specification is based on RC-1009B (Standards of Electric Industries Association of Japan).

(2) Type Designation

(2)-1. Type Designation of taping and IC

Type designation of taping and IC shall be marked on the surface of each reel.

(2)-2. IC direction and type designation

FA13844N - TE □

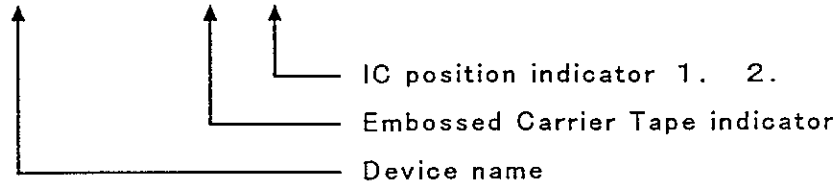

Symbol	Classification by position of the terminal No. 1 relative to unreeling direction.
TE1	The terminal No. 1 in right.
TE2	The terminal No. 1 in left.

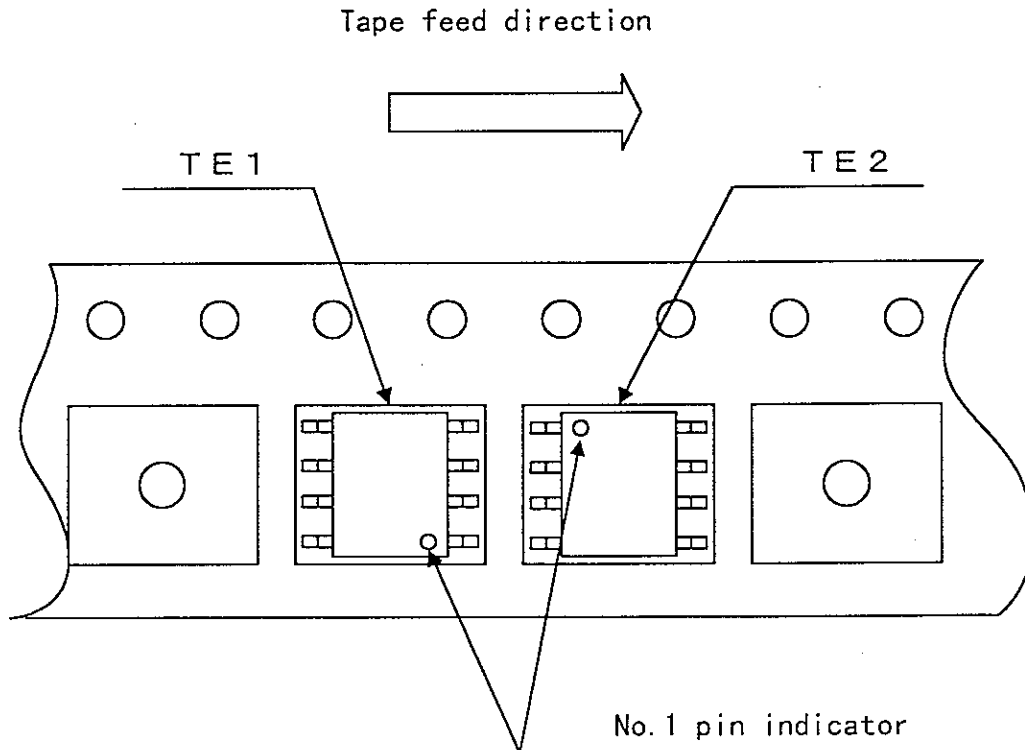

This material and the information herein is the property of Fuji Electric Co., Ltd. They shall be neither reproduced, copied, lent, or disclosed in any way whatsoever for the use of any third party, nor used for the manufacturing purposes without the express written consent of Fuji Electric Co., Ltd.

(3) Taping Specification

(3)-1. Material of Tape

- ① Carrier Tape : Vinyl chloride (antistatic)
- ② Top Cover Tape : Polyester (antistatic)
- ③ Dimensions of Taping

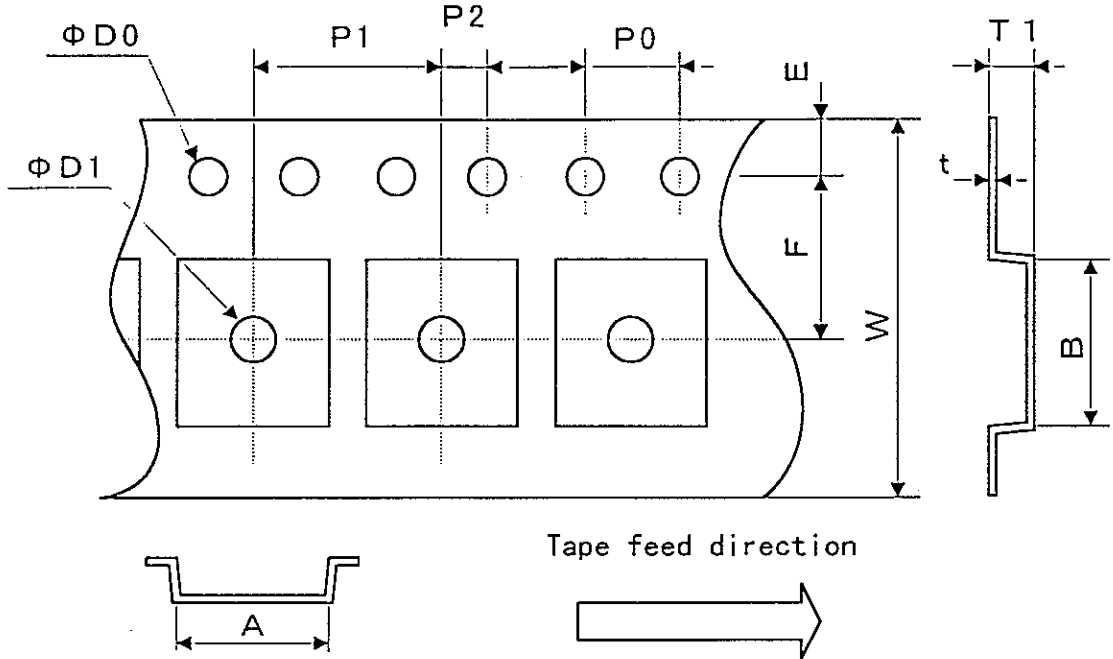

Unit: mm

	A	B	W	F	E	P1	P2	P0	$\Phi D0$	t
SOP-8	7.0	6.3	12.0	5.5	1.75	8.0	2.0	4.0	1.5	0.3
	MAX	MAX	± 0.3	± 0.1	± 0.1	± 0.1	± 0.1	± 0.1	± 0.1	± 0.1

	T1	$\Phi D1$	EIAJ Standard
SOP-8	3.0	1.5	TE1208
	MAX	MIN	

Note: Pitch tolerance over any 10 Pitches of $P0$ is $\leq \pm 0.2\text{mm}$

This material and the information herein is the property of Fuji Electric Co., Ltd. They shall be neither reproduced, copied, lent, or disclosed in any way whatsoever for the use of any third party, nor used for the manufacturing purposes without the express written consent of Fuji Electric Co., Ltd.

(3)-2. Other Specifications of Taping

① Dimension of Leader and Trailer Tape

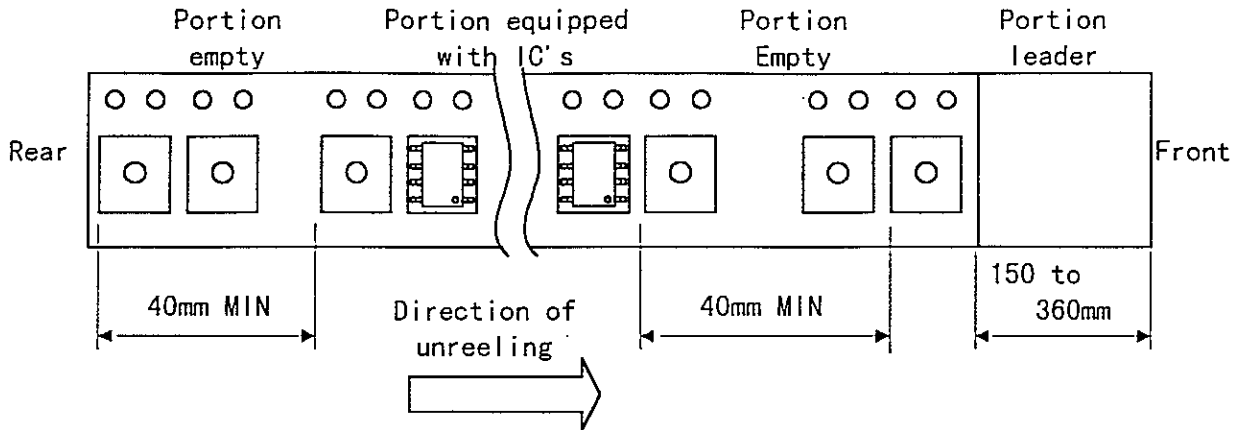

② Strength of Tape

When a tensile force of 10N (1.02kgf) is applied to carrier tape or top cover tape, the tape shall withstand this force.

③ Peel Force of Top Cover Tape

Unless otherwise specified, the peel force of top cover tape shall be 0.1N MIN. (10.2gf MIN.) when the top cover tape is pulled at speed of 300mm/min while the angle between the tape during peel and the direction of unreeling maintained at 165° to 180°.

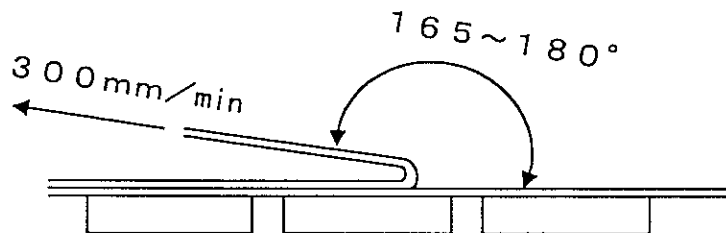

This material and the information herein is the property of Fuji Electric Co., Ltd. They shall be neither reproduced, copied, lent, or disclosed in any way whatsoever for the use of any third party, nor used for the manufacturing purposes without the express written consent of Fuji Electric Co., Ltd.

④ Number of Missing Components

The number of missing components shall not exceed 0.1% of the total number of components (marked number) and no consecutive missing exceeding two is allowed.

(3)-3. Standard of Cover Tape

- ① The material is antistatic.
- ② The Dimension of Cover Tape

Package	Tape Width	Thickness
SOP - 8 pins	9.5 mm	0.06 mm

This material and the information herein is the property of Fuji Electric Co., Ltd. They shall be neither reproduced, copied, lent, or disclosed in any way whatsoever for the use of any third party, nor used for the manufacturing purposes without the express written consent of Fuji Electric Co., Ltd.

(4) Reel Specification

(4)-1. Material of Reel

Reel boss : Styrofoam

Reel plate : Cardboard

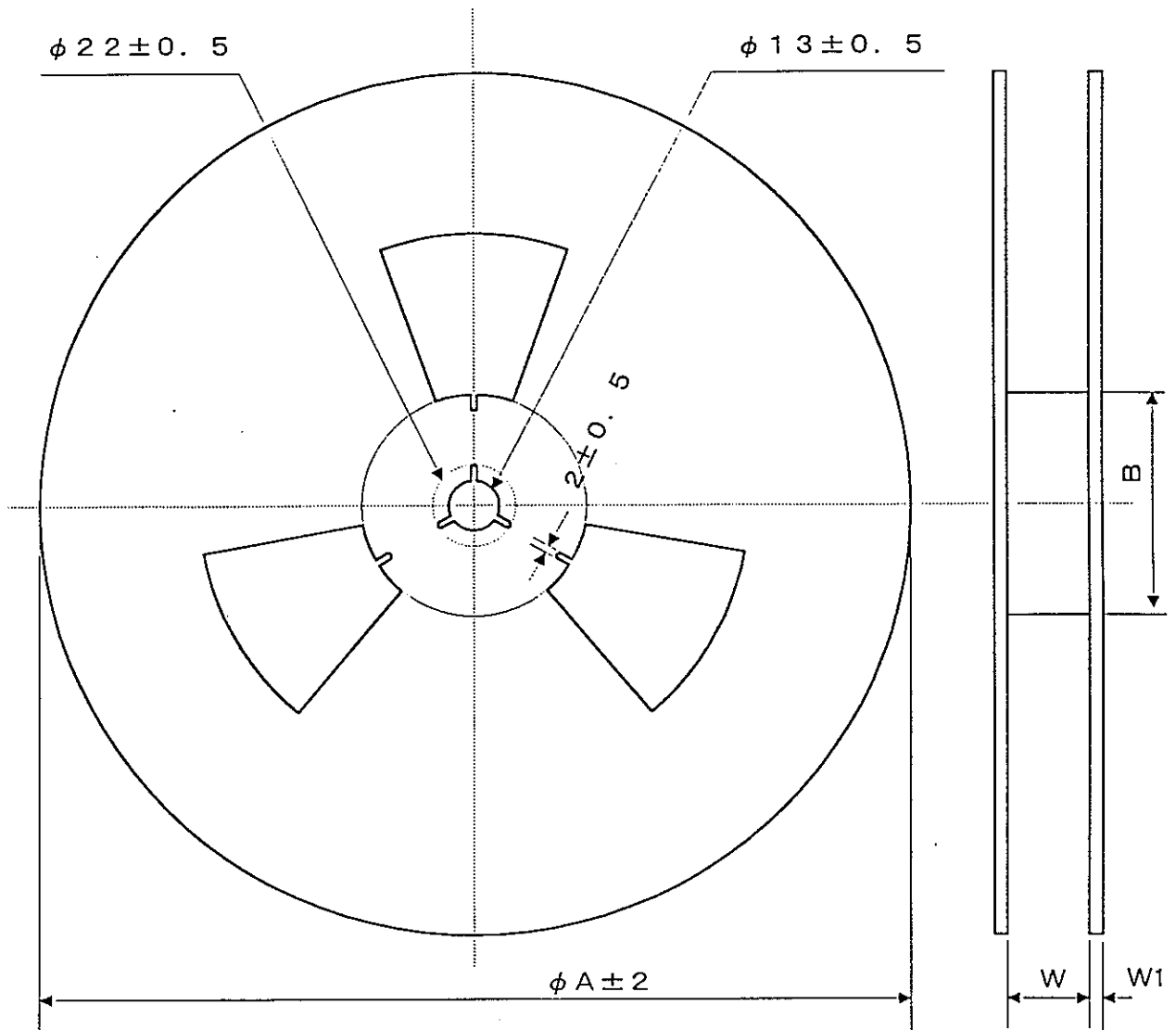

Unit: mm

PACKAGE	TAPE SIZE	A	B	W	W1
SOP-8	12	330	80	$14 \pm \begin{matrix} 1.5 \\ 0 \end{matrix}$	2 ± 0.5

This material and the information herein is the property of Fuji Electric Co., Ltd. They shall be neither reproduced, copied, lent, or disclosed in any way whatsoever for the use of any third party, nor used for the manufacturing purposes without the express written consent of Fuji Electric Co., Ltd.

(5) Packaging

(5)-1. Quantity

In generally, one reel can hold up to 2000 IC's.

(5)-2. Marking

The following items shall be marked on the surface of each reel and package box.

- ① Type designation of taping and IC
- ② Quantity
- ③ Lot number

(5)-3. Packaging (refer to next page)

The taped products shall be contained in package boxes and then so packaged that will not be damaged during transportation or storage.

(6) Transportation and Storage

In order to prevent deterioration in performance such as change in adhesive force or peel force, the taped products should be stored at a temperature -10 to $+40^{\circ}\text{C}$ and a relative humidity 40 to 60% without exposed to direct sunlight and shock.

This material and the information herein is the property of Fuji Electric Co., Ltd. They shall be neither reproduced, copied, lent, or disclosed in any way whatsoever for the use of any third party, nor used for the manufacturing purposes without the express written consent of Fuji Electric Co., Ltd.

(7) Packing Case

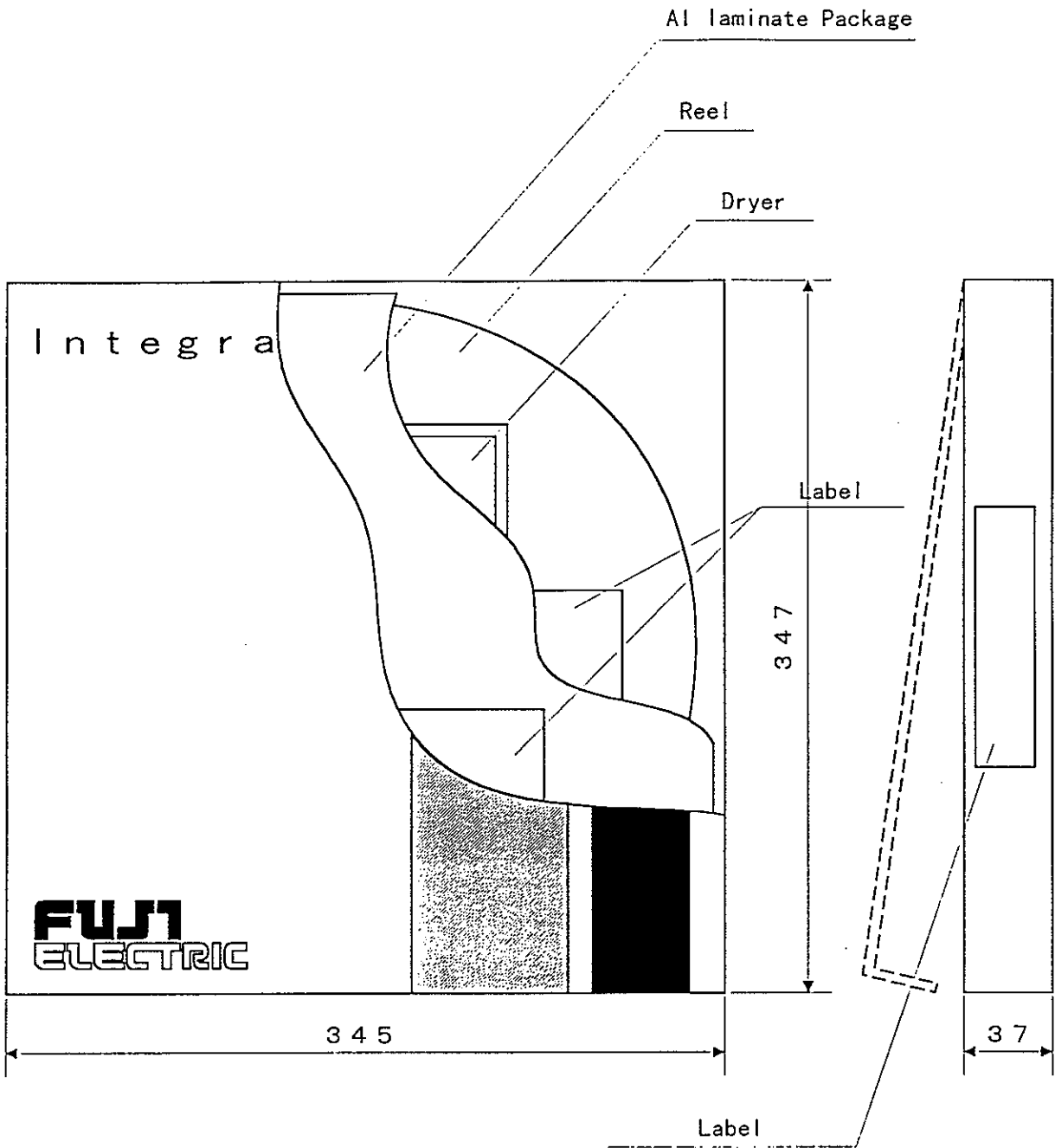

This material and the information herein is the property of Fuji Electric Co., Ltd. They shall be neither reproduced, copied, lent, or disclosed in any way whatsoever for the use of any third party, nor used for the manufacturing purposes without the express written consent of Fuji Electric Co., Ltd.
