

FAN5607

LED Driver with Adaptive Charge Pump DC/DC Converter

Features

- Parallel LED Driver Supports all Forward Voltages
- Adaptive V_{OUT} Adjustment to the Highest Diode Voltage
- Internally Matched LED Current Sources
- Built-in Charge Pump has Three Modes of Operation:
 - 1X, 1.5X, and 2X Mode
- Up to 93% Efficiency
- Low EMI, Low Ripple
- Up to 120mA Output Current ($4 \times 30\text{mA}$)
- External Resistor to Set Maximum (100%) LED Current
- Enable Input Can be Duty-Cycle-Modulated to Control LED Current Level Between 0 and 100%
- 2.4V to 5.5V Input Voltage Range
- $I_{CC} < 1\mu\text{A}$ in Shutdown Mode
- 1MHz Operating Frequency
- Shutdown Isolates Output from Input
- Soft-Start Limits Inrush Current
- Short Circuit Protection
- Minimal External Components Needed
- Available in a 4x4mm 16-lead MLP Package

Applications

- Cell Phones
- Handheld Computers
- PDA, DSC, MP3 Players
- Keyboard Backlight
- LED Displays

Typical Application

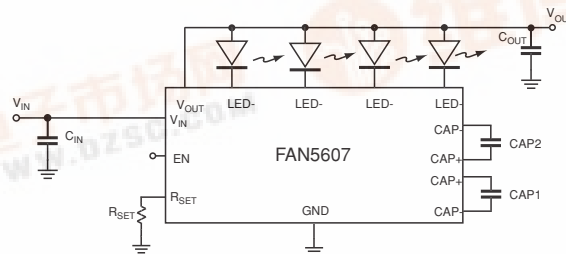

Description

The FAN5607 generates regulated output current from a battery with input voltage varying between 2.7V to 5.5V. Switch reconfiguration and fractional switching techniques are utilized to achieve high efficiency over the entire input voltage range. A proprietary internal circuitry continuously monitors each LED current loop and automatically adjusts the generated output DC voltage to the lowest minimum value required by the LED having the highest forward voltage. This adaptive nature of the FAN5607 eliminates the need for LED pre-selection (matching) and ensures operation at high efficiency. When the input voltage is sufficiently high to sustain the programmed current level in the LEDs, the FAN5607 re-configures itself to operate as a linear regulator, and the DC-DC converter is turned off. Only two 0.1 μF to 1 μF bucket capacitors and two 4.7 μF input/output capacitors are needed for proper operation. LED current can be programmed using an external resistor. The resistor sets the maximum LED current and a PWM signal applied to the enable pin can modulate that current level between 0mA (off) and the maximum level.

Soft-start circuitry prevents excessive current draw during power on. The device has built-in short circuit protection.

The device is available in 4x4mm 16-lead MLP package.

Definition of Terms

Output Current Accuracy: reflects the difference between the measured value of the output current (LED) and programmed value of this current.

$$\text{Output Current Accuracy (\%)} = \frac{(I_{\text{OUT measured}} - I_{\text{OUT programmed}}) \times 100}{I_{\text{OUT programmed}}}$$

Current Matching: refers to the absolute value of difference in current between the two LED branches.

$$\text{Current Matching (\%)} = \frac{|(I_{\text{LED branch 1}} - I_{\text{LED branch 2}}) \times 100|}{(I_{\text{LED branch 1}} + I_{\text{LED branch 2}})}$$

Efficiency: is expressed as a ratio between the electrical power into the LEDs and the total power consumed from the input power supply.

$$\text{Efficiency} = \frac{\sum_{i=1}^4 V_{\text{LED}i} \times I_{\text{LED}i}}{V_{\text{IN}} \times I_{\text{IN}}}$$

Note:

1. Some competitors calculate the power efficiency as a function of V_{OUT} instead of V_{LED} . This method neglects the power lost due to the cathode voltage $\neq 0$ and provides an efficiency "improved" up to 5%.

Pin Assignments

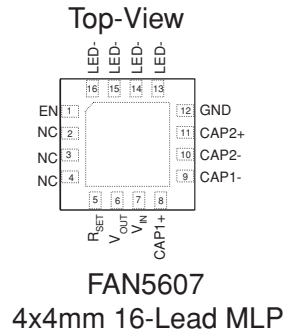

Pin Descriptions

Pin No.	Pin Name	Pin Function Description
1	EN	Enable Pin
2	NC	No Connection
3	NC	No Connection
4	NC	No Connection
5	R _{SET}	External resistor to set LED current
6	V _{OUT}	Output to LEDs Anode
7	V _{IN}	Input
8	CAP1+	Bucket capacitor positive connection
9	CAP1-	Bucket capacitor negative terminal
10	CAP2-	Bucket capacitor negative connection
11	CAP2+	Bucket capacitor positive terminal
12	GND	Ground
13	LED-	4th LED Cathode
14	LED-	3rd LED Cathode
15	LED-	2nd LED Cathode
16	LED-	1st LED Cathode

Test Circuit

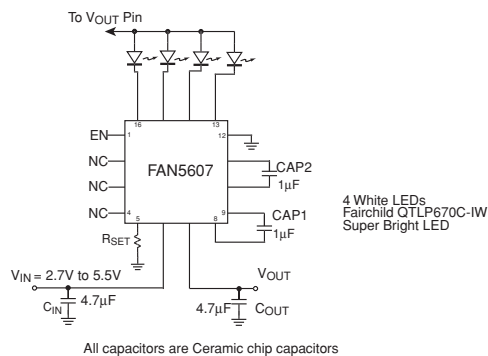

Figure 1. Test Circuit

Absolute Maximum Ratings (Note 2)

Parameter	Min	Max	Unit
V_{IN} , V_{OUT} Voltage to GND	-0.3	6.0	V
Any other Pin Voltage to GND	-0.3	$V_{IN} + 0.3$	V
Power Dissipation		Internally Limited	
Lead Soldering Temperature (10 seconds)		300	°C
Operating Junction Temperature Range		150	°C
Storage Temperature	-55	150	°C
Electrostatic Discharge Protection Level (Note 3)	HBM	4	kV
	CDM	2	

Recommended Operating Conditions

Parameter	Min	Typ	Max	Unit
Input Voltage Range, V_{IN}	2.4		5.5	V
Operating Ambient Temperature Range	-40	25	85	°C
LED Forward Voltage			4	V
Current through each LED	2		30	mA

Note:

- Operation beyond the absolute maximum ratings may cause damage to device.
- Using Mil Std. 883E, method 3015.7(Human Body Model) and EIA/JESD22C101-A (Charge Device Model)

Electrical Characteristics

$V_{IN} = 2.7V$ to $5.5V$, $T_A = -40^{\circ}C$ to $+85^{\circ}C$, Test Circuit Figure 1, Unless otherwise noted.
Typical values are at $T_A = 25^{\circ}C$

Parameter	Conditions	Min.	Typ.	Max.	Units
Input Undervoltage Lockout		1.7	1.8	2.3	V
I_{LED} Accuracy	$I_{LED} \leq 20mA$		5		%
Current Matching	$I_{LED} \leq 20mA$		3		%
Output Voltage ($V_{OUT} = V_f + V_{Cathode}$)	LED $V_f = 3.5V$		3.62		V
Quiescent Current, I_Q	$V_{IN} = 5.5V$, $I_{OUT} = 0mA$		130	400	μA
Shutdown Supply Current	$V_{EN} = 0V$			1	μA
Output Short Circuit Current	$V_{IN} = 5.5V$, $V_{OUT} = 0V$		65		mA
V_{OUT} Over Voltage Protection			5.1		V
V_{IN} At Mode Transition From 1X to 1.5X	LED $V_f = 3.5V$, $I_{OUT} = 4 \times 20mA$		3.76		V
V_{IN} At Mode Transition From 1.5X to 2X	LED $V_f = 3.5V$, $I_{OUT} = 4 \times 20mA$		2.85		V
Peak Efficiency	$V_{IN} = 3.75V$, LED $V_f = 3.5V$, $I_{LED} = 20mA$		93		%
Oscillator Frequency		0.8	1	1.2	MHz
Thermal Shutdown Threshold			145		$^{\circ}C$
Thermal Shutdown Hysteresis			15		$^{\circ}C$
EN Logic Input High Voltage		1.6			V
EN Logic Input Low Voltage				0.4	V
EN Input Bias Current	EN to V_{IN} or GND	-1		1	μA

Typical Performance Characteristics

$T_A = 25^\circ\text{C}$, $C_{IN} = C_{OUT} = 4.7\mu\text{F}$, $CAP1 = CAP1 = 0.1\mu\text{F}$, FAN5607 driving four LEDs with $V_f = 3.5\text{V}$ at 20mA , unless otherwise noted.

Efficiency vs Battery Voltage

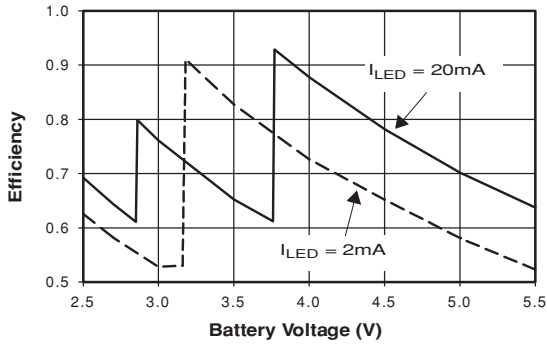

Upper Mode Change Voltage vs LED Forward Voltage

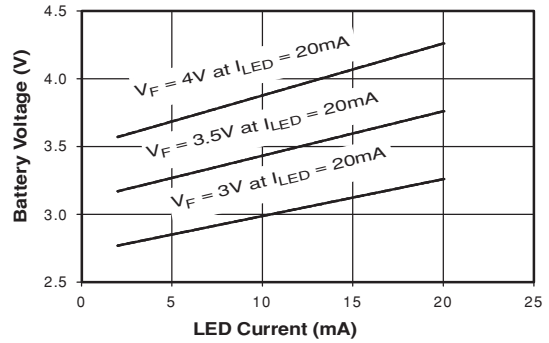

LED Cathode Voltage vs Battery Voltage

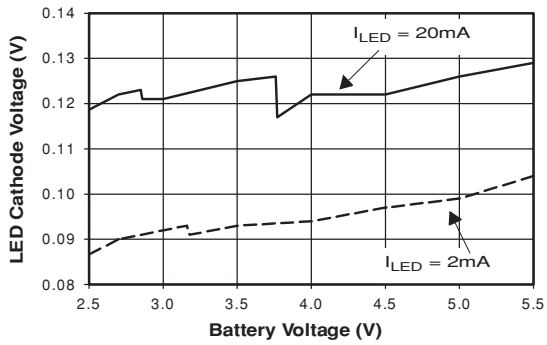

LED Current vs Battery Voltage

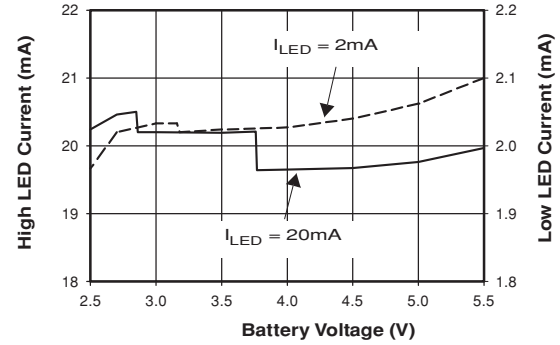

Supply Current vs Battery Voltage

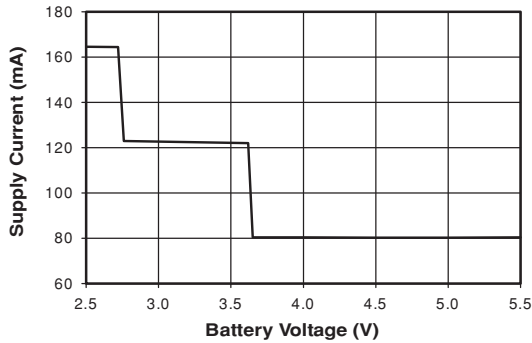

Typical Performance Characteristics (cont.)

$T_A = 25^\circ\text{C}$, $C_{IN} = C_{OUT} = 4.7\mu\text{F}$, $CAP1 = CAP1 = 0.1\mu\text{F}$, FAN5607 driving four LEDs with $V_f = 3.5\text{V}$ at 20mA , unless otherwise noted.

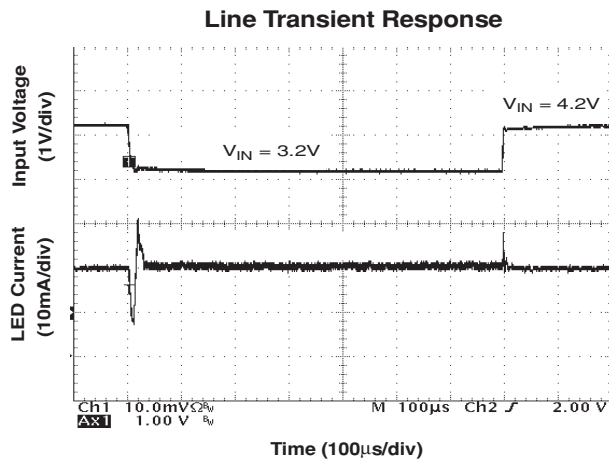
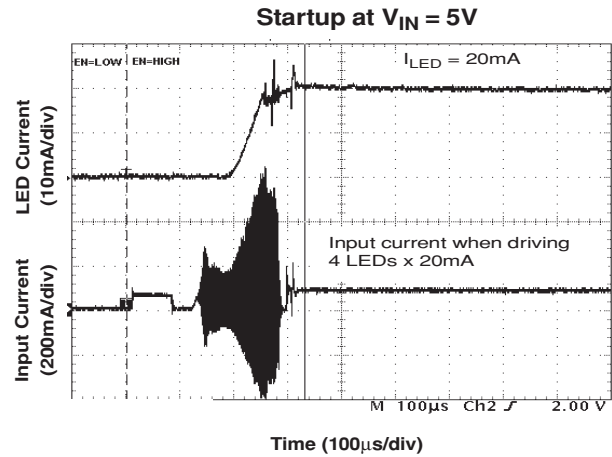
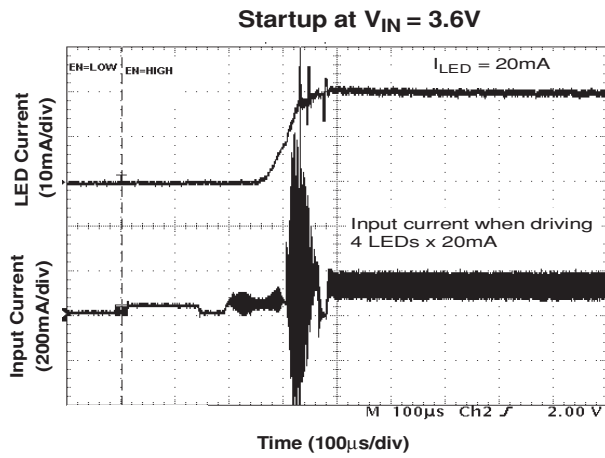

Block Diagram

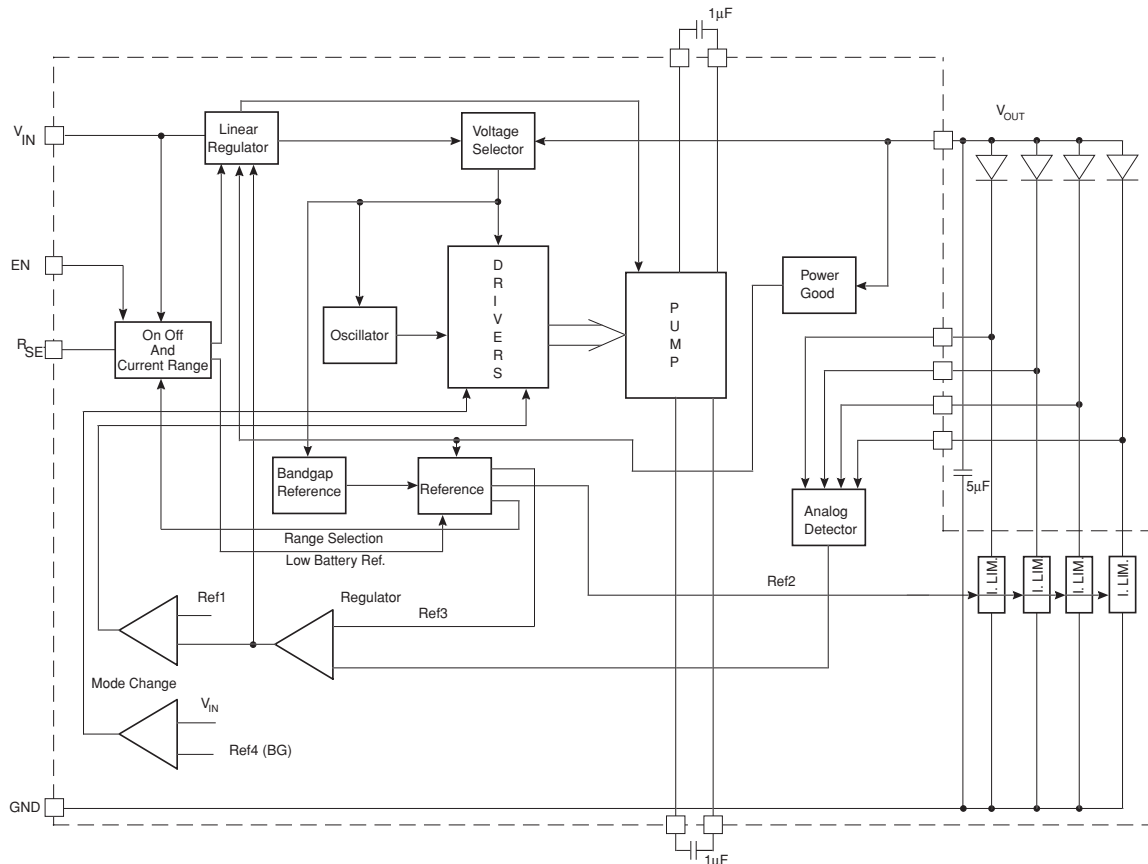

Figure 2. Block Diagram

Circuit Description

The FAN5607's switched capacitor DC/DC converter automatically configures its internal switches to achieve high efficiency and to provide tightly regulated output currents for the LEDs. An analog detector determines which diode requires the highest voltage in order to sustain the pre-set current levels, and adjusts the pump regulator accordingly. Every diode has its own linear current regulator. In addition, a voltage regulator controls the output voltage when the battery voltage is within a range where linear regulation can provide maximum possible efficiency. If the battery voltage is too low to sustain the diode current in the linear mode, a fractional 3:2 charge pump is enabled. When the battery voltage drops further and this mode is no longer sufficient to sustain proper operation, the pump is automatically reconfigured to operate in 2:1 mode. As the battery discharges and

the voltage decays, the FAN5607 switches between modes to maintain a constant current through LED throughout the battery life. The transition has hysteresis to prevent toggling.

Supply Voltage

The internal supply voltage for the device is automatically selected from V_{IN} or V_{OUT} pins, whichever is higher.

Soft Start

The soft-start circuit limits inrush current when the device is initially powered up and enabled. The reference voltage controls the rate of the output voltage ramp-up to its final value. Typical start-up time is 0.4ms. The rate of the output voltage ramp-up is controlled by an internally generated slow ramp, and an internal variable resistor limits the input current.

Switch Configurations

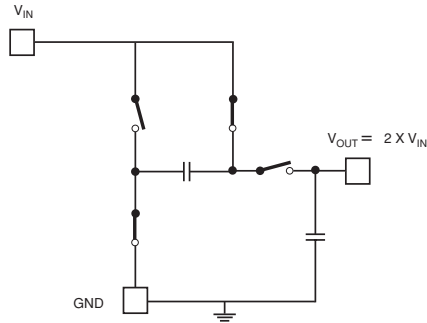

Figure 3. Step-up, 2:1 Configuration
 Switch positions shown in charge phase
 Reverse all switches for pump phase

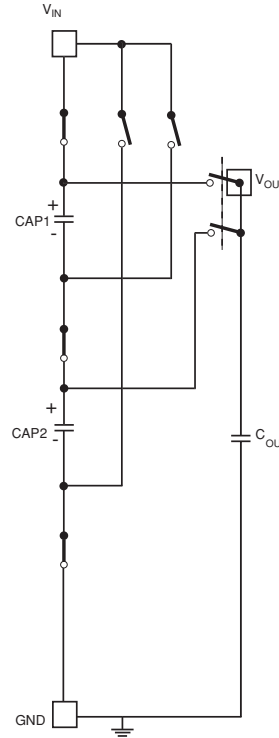

Figure 4. Step-up, 3:2 Configuration
 Switch positions shown in charge phase
 Reverse all switches for pump phase

Shutdown and Short Circuit Current Limit

Set both DAC inputs low to shut down the device. Built-in short circuit protection limits the supply current to a maximum of 65mA.

LED Brightness Control Methods

R_{SET} Only-Analog

The basic method is to use external resistor to set the LED current. Connect the resistor with the appropriate value between R_{SET} and GND to set the LED current.

R _{SET} (KΩ)	8.25	12.5	25	50	62.5
I _{LED} (mA)	30	20	10	5	4

The resistor value establishes the reference current needed for a constant LED current. Value of R_{SET} for a fixed LED current are given in the table above and also in the graph below, using the function: $R_{SET} = 250/I_{LED}$.

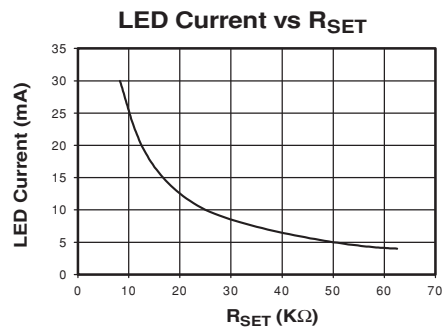

PWM Control

Unless otherwise noted, $R_{SET} = 12.5K\Omega$, $I_{LED_MAX} = 20mA$

Enable is Controlled by PWM Signal

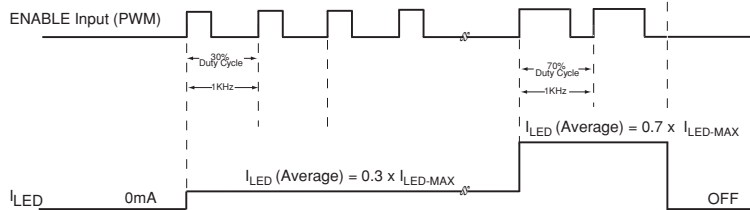

PWM Control

Once R_{SET} is chosen to set maximum LED current (I_{LED_MAX}), PWM modes can be used for brightness control. By turning the ENABLE pin ON and OFF, the current can be modulated between 0 to I_{LED_MAX} to achieve any $I_{Average}$ value. In PWM mode, the modulating frequency has to be set sufficiently high in order to avoid a flickering effect (50Hz to 100Hz).

The best LED to LED matching and the purest white light are achieved over the entire range of average current settings, when the PWM brightness control is used to modulate the LED current between zero and the maximum value.

Application Information

Brightness Control

1. Dimming Using PWM at EN Pin

A PWM signal applied to EN can control the LED brightness in direct dependence on the duty cycle. The recommended PWM signal frequency is 100Hz to ensure a good match between the input signal duty cycle and the LED average current. If this ripple frequency is too low for a particular noise sensitive application, then DC-based dimming control circuits or higher-frequency-filtered PWM signals may be used.

2. Dimming with DC Voltage

The brightness control using a variable DC voltage is shown in Figure 5. If $R1=125k\Omega$, $R2=13.9k\Omega$, adjusting V_{EXT} in the (0V to 0.5V) range results in dimming the LED current from 20mA to 2mA.

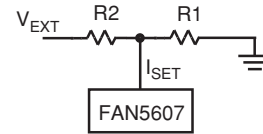

Figure 5. DC Voltage Control

The FAN5607 internal circuit maintains a constant I_{SET} voltage = 0.5V. Adjusting V_{EXT} changes the I_{SET} and I_{LED} accordingly.

Selecting different values for $R1$, $R2$ and V_{EXT} range, the I_{LED} variation range can be changed according to the relation:

$$I_{LED} = \frac{250}{R1} + \frac{(250 - 500 \times V_{EXT})}{R2} \text{ mA}$$

Where $0V < V_{EXT} < 0.5V$ and $R1$ and $R2$ are in $K\Omega$.

3. Dimming Using a Filtered PWM Signal

The external PWM signal is filtered by an R3C network resulting in a DC component dependent on the PWM signal duty cycle as shown in Figure 6. The resistor $R3$ needs to be much smaller than $R2$ and the corner frequency of R3C group is much smaller than the PWM signal frequency.

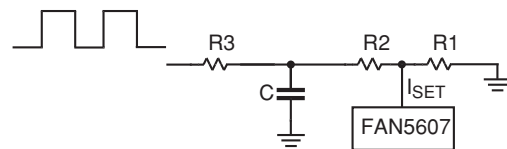

Figure 6. Filtered PWM Control

Selecting Capacitors

It is important to select the appropriate capacitor types and the values for use with the FAN5607. These capacitors determine parameters such as power efficiency, maximum sustainable load current by the charge pump, input and output ripple and start-up process.

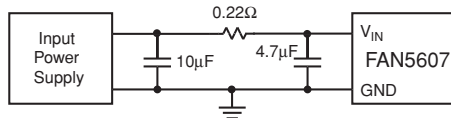

Figure 7. Battery Ripple Reduction

In order to reduce ripple, both C_{IN} and C_{OUT} should be low ESR capacitors. Increasing the C_{OUT} capacitor reduces the output ripple voltage. However this will increase the power-on time. The C_{IN} value controls input ripple. If necessary, this ripple can be further reduced by powering the FAN5607

through the RC input filter, as shown in Figure 7. Two low ESR bucket capacitors of value between $0.1\mu\text{F}$ to $1\mu\text{F}$, should be used for best efficiency in boost mode. The bucket capacitor, $CAP1 = CAP2 = 1\mu\text{F}$ is recommended, if the FAN5607 is required to start at battery voltage lower than 3V.

PC Board Layout

For best performance, a solid ground plane is recommended on the back side of the PCB. The ground tails of C_{IN} and C_{OUT} should be connected together close to the GND pin of IC.

Mechanical Dimensions

4x4mm 16-Lead MLP Package

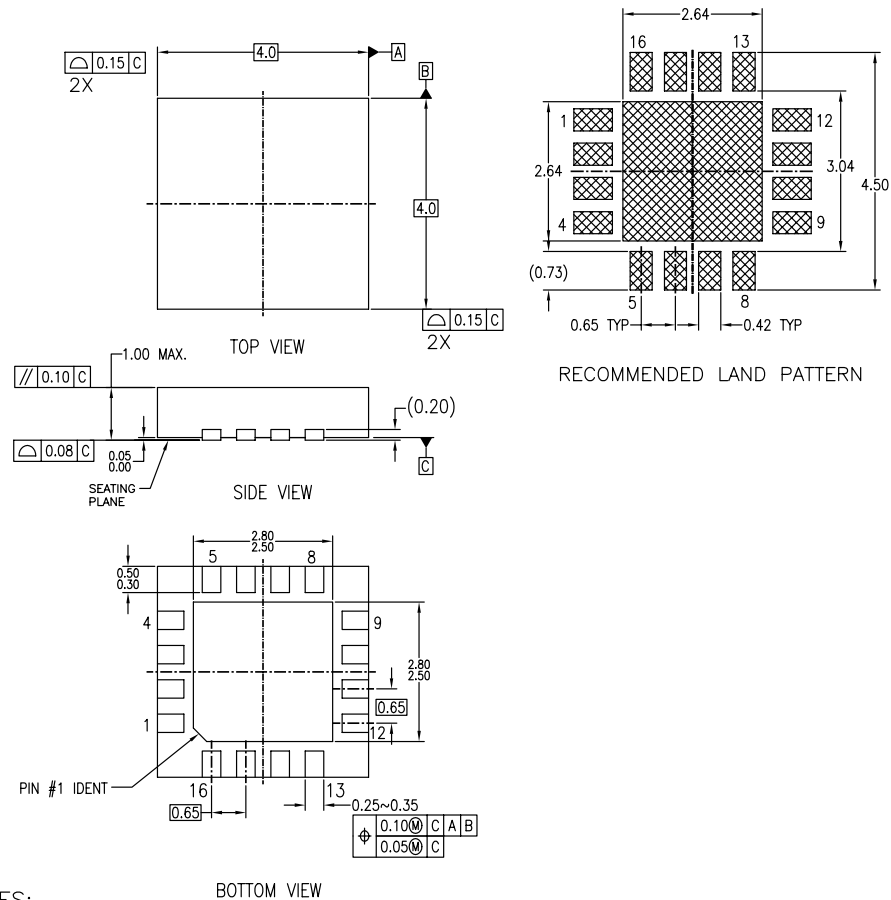

NOTES:

- A. CONFORMS TO JEDEC REGISTRATION MO-220, VARIATION VGGC-3, DATED AUG/2002
- B. DIMENSIONS ARE IN MILLIMETERS.
- C. DIMENSIONS AND TOLERANCES PER ASME Y14.5M, 1994

Ordering Information

Product Number	Package Type	Order Code
FAN5607	4x4mm 16-Lead MLP	FAN5607HMPX

DISCLAIMER

FAIRCHILD SEMICONDUCTOR RESERVES THE RIGHT TO MAKE CHANGES WITHOUT FURTHER NOTICE TO ANY PRODUCTS HEREIN TO IMPROVE RELIABILITY, FUNCTION OR DESIGN. FAIRCHILD DOES NOT ASSUME ANY LIABILITY ARISING OUT OF THE APPLICATION OR USE OF ANY PRODUCT OR CIRCUIT DESCRIBED HEREIN; NEITHER DOES IT CONVEY ANY LICENSE UNDER ITS PATENT RIGHTS, NOR THE RIGHTS OF OTHERS.

LIFE SUPPORT POLICY

FAIRCHILD'S PRODUCTS ARE NOT AUTHORIZED FOR USE AS CRITICAL COMPONENTS IN LIFE SUPPORT DEVICES OR SYSTEMS WITHOUT THE EXPRESS WRITTEN APPROVAL OF THE PRESIDENT OF FAIRCHILD SEMICONDUCTOR CORPORATION. As used herein:

1. Life support devices or systems are devices or systems which, (a) are intended for surgical implant into the body, or (b) support or sustain life, and (c) whose failure to perform when properly used in accordance with instructions for use provided in the labeling, can be reasonably expected to result in a significant injury of the user.
2. A critical component in any component of a life support device or system whose failure to perform can be reasonably expected to cause the failure of the life support device or system, or to affect its safety or effectiveness.