



FAN8047G3

4-CH Motor Driver (5 Input & 4 Output)

Features

- 4-CH Balanced transformerless (BTL) driver
- Optional input (CH4,5) for output CH4
- Operating supply voltage : 4.5 V ~ 14V
- Built-in thermal shut down circuit (TSD)
- Built-in channel mute circuit
- Built-in 3.3 volt regulator

Description

The FAN8047G3 is a monolithic integrated circuit suitable for a 4-ch motor driver which drives a tracking actuator, a focus actuator, a sled motor, a spindle motor, and a tray motor of the CDP/CAR-CD/DVDP systems.

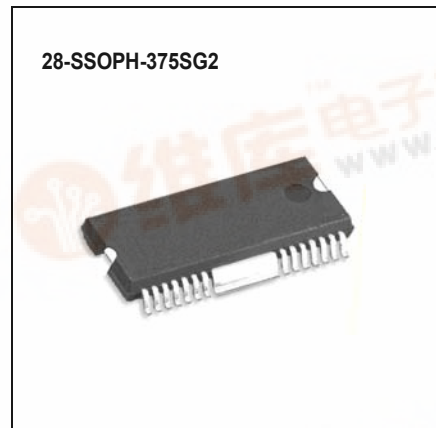

Typical Application

- Compact disk player
- Video compact disk player
- Car compact disk player
- Digital video disk player

Ordering information

DEVICE	PACKARE	OPERATING TEMP
FAN8047G3	28-SSOPH-375-SG2	-35°C ~ +85°C
FAN8047G3X ^{note1}	28-SSOPH-375-SG2	-35°C ~ +85°C
FAN8047G3_NL ^{note2}	28-SSOPH-375-SG2	-35°C ~ +85°C
FAN8047G3X_NL	28-SSOPH-375-SG2	-35°C ~ +85°C

Notes:

1. X : Tape&Reel
2. NL : Lead free

Pin assignments



Pin definitions

PIN NUMBER	PIN NAME	I/O	PIN FUNCTION DESCRIPTION
1	REF1	I	Bias voltage input
2	IN1	I	CH1 Input
3	IN2	I	CH2 Input
4	RESX	I	Regulator reset
5	REGOX	I	Regulator feedback input
6	REGX	O	Regulator output
7	GND	-	Signal ground
8	PVcc1	-	Power Vcc (CH1,CH2)
9	MUTE12	I	Mute 1,2
10	GND	-	Power ground (CH1,CH2)
11	DO2-	O	CH2 Drive output (-)
12	DO2+	O	CH2 Drive output (+)
13	DO1-	O	CH1 Drive output (-)
14	DO1+	O	CH1 Drive output (+)
15	DO4+	O	CH4 Drive output (+)
16	DO4-	O	CH4 Drive output (-)
17	DO3+	O	CH3 Drive output (+)
18	DO3-	O	CH3 Drive output (-)
19	GND	-	Power ground (CH3,CH4)
20	MUTE4	I	Mute 4
21	PVcc2	-	Power Vcc (CH3,CH4)
22	SVcc	-	Signal Vcc
23	IN3	I	CH3 Input
24	IN4	I	CH4 Input
25	REF2	I	REF2
26	IN5	I	CH5 Input
27	MUTE3	I	Mute 3
28	SW45	I	Select switch for CH4,5

Internal block diagram

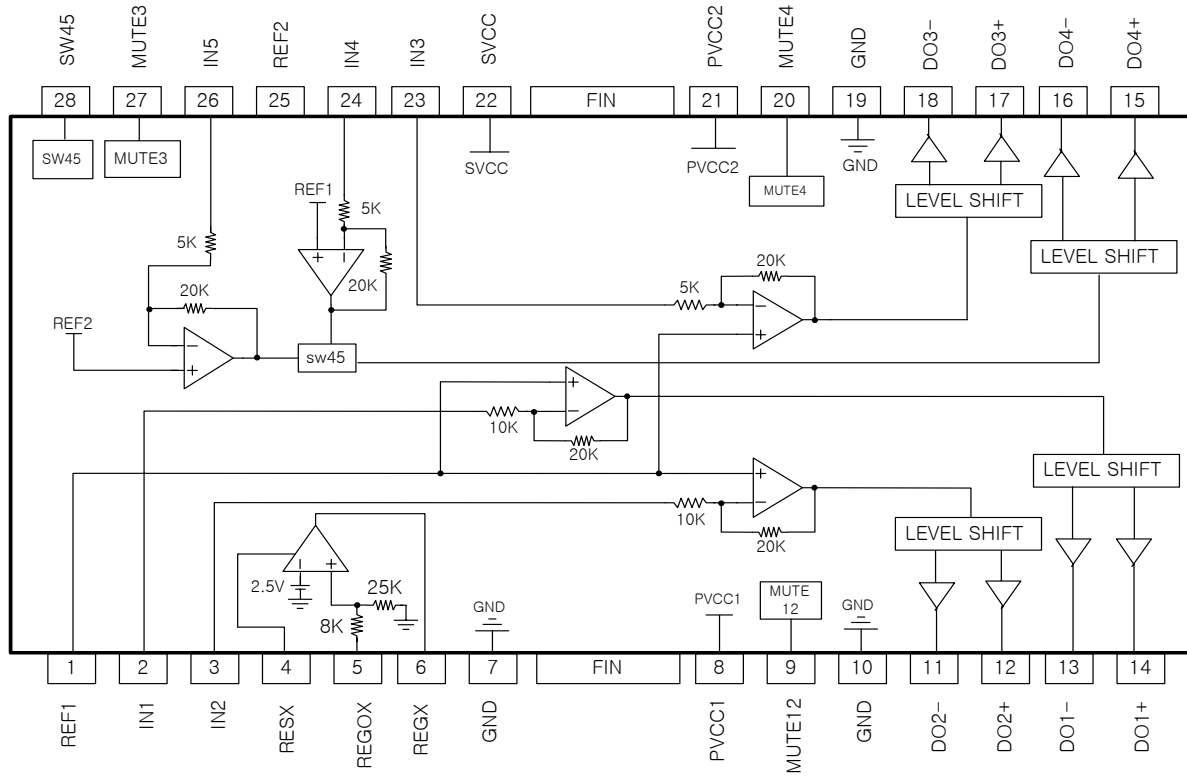

Equivalent circuits

<p style="text-align: center;">BTL Driver output</p>	<p style="text-align: center;">SW45</p>
<p style="text-align: center;">BTL Input(CH1,2)</p>	<p style="text-align: center;">BTL Input(CH3,4,5)</p>
<p style="text-align: center;">Mute</p>	<p style="text-align: center;">Reference</p>

Equivalent circuits(Continued)

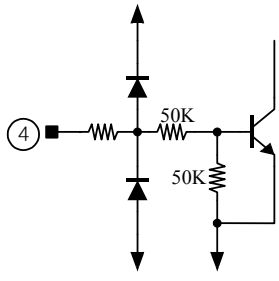
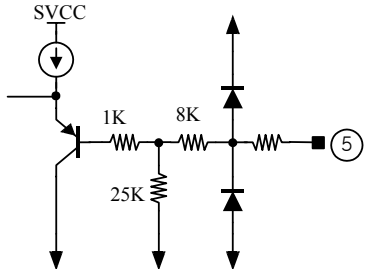
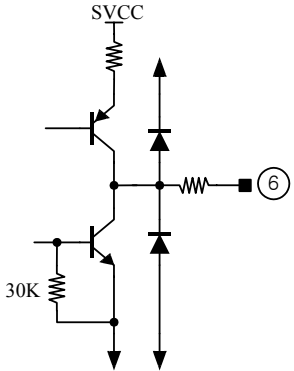
Regulator reset	Regulator feedback input
	
Regulator output	
	

Absolute maximum ratings (Ta=25°C)

PARAMETER	SYMBOL	VALUE	UNIT
Maximum supply voltage	SVCCMAX	18	V
	PVCC1MAX	18	V
	PVCC2MAX	18	V
Power dissipation	P _D	2.5 ^{note1,2,3}	W
Operating temperature	TOPR	-35 ~ +85	°C
Storage temperature	TSTG	-55 ~ +150	°C
Maximum output current	IOMAX	1	A

Notes:

1. When it is mounted on 70mm × 70mm × 1.6mm PCB.
2. Power dissipation decreases at the rate of 20mW/°C in T_A >25°C.
3. Do not exceed P_D and SOA.

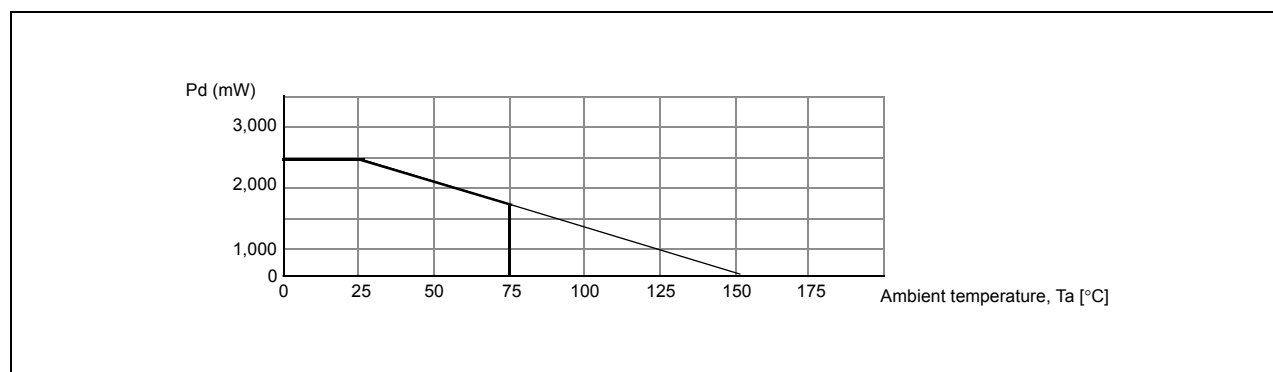

Recommended operating conditions (Ta=25°C)

PARAMETER	SYMBOL	MIN	TYP	MAX	UNIT
Operating supply voltage	SVCC	4.5	-	14	V
	PVCC1	4.5	-	SVCC	V
	PVCC2	4.5	-	SVCC	V

Electrical characteristics

(SVCC = PVCC2 = 12V, TA = 25°C, PVCC1 = 5V, Ref1 = 1.65V, Ref2 = 2.5V, RL = 8Ω)

PARAMETER	SYMBOL	CONDITIONS	MIN	TYP	MAX	UNITS
Quiescent circuit current	ICC	Under no-load	-	17	25	mA
BTL Driver circuit (RL=8Ω)						
Output offset voltage(CH12)	VOOF1	VIN=1.65V	-50	-	+50	mV
Output offset voltage(CH34)	VOOF2	VIN=1.65V	-100	-	+100	mV
Output offset voltage(CH5)	VOOF3	VIN=2.5V	-100	-	+100	mV
Maximum output voltage(CH12)	VOM1	PVcc1=5V, RL=8Ω	3.6	4.0	-	V
Maximum output voltage(CH34)	VOM2	PVcc2=12V, RL=24Ω	9.6	10.5	-	V
Close-loop voltage gain(CH12)	AVF	VIN= 0.3V	15.5	17.5	19.5	dB
Close-loop voltage gain(CH34)	AVF	VIN= 0.3V	21.5	23.5	25.5	dB
Regulator circuit (SVCC,PVCC2=12V)						
Load regulation	ΔVRL	IL=0 → □ 200mA	-10	0	+10	mV
Line regulation	ΔVCC	IL=200mA, V=6V → □ 9V	-20	0	+30	mV
Regulator output voltage 1	VREG1	IL=100mA	3.135'	3.3	3.465	V
Regulator reset on voltage	Reson	Pin4=Variation	-	-	0.5	V
Regulator reset off voltage	Resoff	Pin4=Variation	2	-	-	V
Mute and other function circuit						
Mute on voltage	VMON	Pin9,20,27=Variation	-	-	0.5	V
Mute off voltage	VMOFF	Pin9,20,27=Variation	2	-	-	V
SW on voltage	VSWL	Pin28=Variation	-	-	0.5	V
SW off voltage	VSWH	Pin28=Variation	2	-	-	V
Mute low level sink current	IMTL	VMUTE = 0V	-15	0	15	uA
Mute high level sink current	IMTH	VMUTE = 5V	-	85	170	uA
SW45 Low level sink current	ISWL45	SW45 = 0V	-15	0	15	uA
SW45 High level sink current	ISWH45	SW45 = 5V	-	85	170	uA
REF1 Sink current	IRL	REF1 = 1.65V	-	52	104	uA
REF2 Sink current	IRH	REF2 = 2.5V	-	85	170	uA

(* note) : Guaranteed field. (No EDS/ Final test .)

Application information

1. MUTE, REF & SW45 Function

INPUT						OUTPUT					
SW45	MUTE12	MUTE3	MUTE4	REF1	REF2	BTL			PRE-AMP		REG
						CH12	CH3	CH4	CH4	CH5	
H	H	H	-	H	-	ON	ON	IN4	ON	ON	ON
H	H	L	-	H	-	ON	OFF	IN4	ON	ON	ON
H	H	H	-	L	-	OFF	OFF	OFF	OFF	ON	ON
H	L	H	-	H	-	OFF	ON	OFF	ON	ON	ON
H	L	L	-	H	-	OFF	OFF	OFF	ON	ON	ON
L	-	-	L	-	-	OFF	OFF	OFF	OFF	ON	ON
L	-	-	H	-	H	OFF	OFF	IN5	OFF	ON	ON
L	-	-	H	-	L	OFF	OFF	OFF	OFF	ON	ON

2. Regulator & Reset function

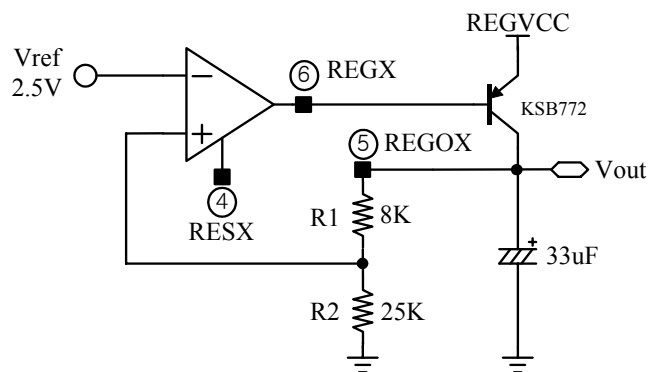

- The external circuit is composed of the transistor, KSB772 and a capacitor, about 33uF.
- The capacitor is used as a ripple eliminator.
- The capacitor must have a good temperature characteristics.
- The regulator output voltage is decided as follows.

$$\begin{aligned}
 V_{out} &= V_{ref} \times \left(1 + \frac{R1}{R2}\right) \\
 &= 2.5 \times \frac{8K}{25K} = 3.3V
 \end{aligned}$$

- When the voltage of the pin 4(RESX) is high, the regulator circuit operates normally. When the voltage of pin 4(RESX) is low, the regulator circuit is disabled.

3. TSD Function

- When the chip temperature reaches to 160°C by abnormal condition, the TSD circuit is activated.
- This makes the bias current of the output drivers shut down, and all the output drivers are on cut-off state. Therefore the chip temperature begins to decrease.
- When the chip temperature falls to 140°C, the TSD circuit is deactivated and the output drivers start to operate normally.
- The TSD function does not affect regulator operation.

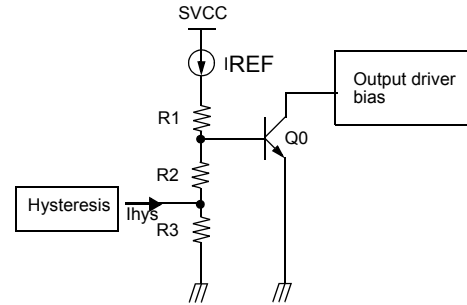

4. Notice

- When REF1(pin1) or REF2(pin25) is lower than 0.7V, BTL output is off.
- Under Voltage Protection Function. (If SVcc is lower than 3.8V, Chip is disable. Hysteresis is 0.2V)
- Mute on BTL output voltage is as followed:
 - Mute ON BTL Output (CH1,2) = (PVcc1) / 2
 - Mute ON BTL Output (CH3,4) = ((PVcc2-0.6) / 2

Each output to output and output to GND short should be kept away.

Typical performance characteristics

Total circuit

I_{cc}(mA)

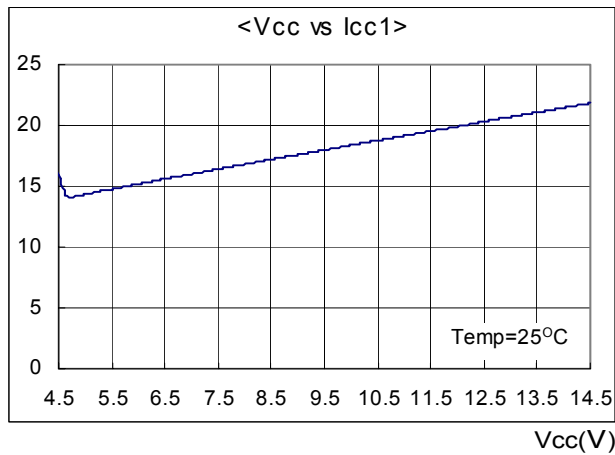

I_{cc}(mA)

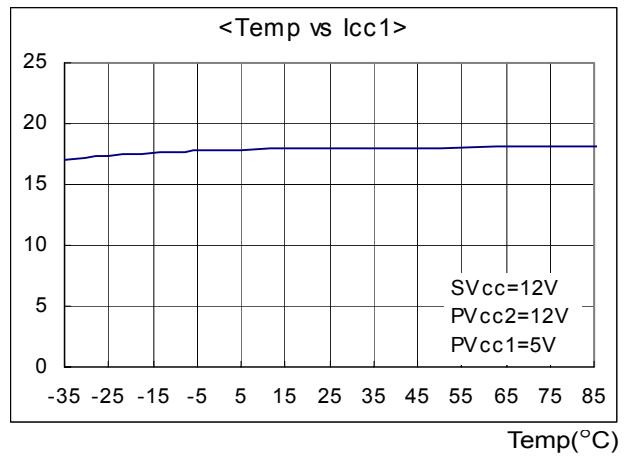

BTL Drive part

V_{om}(V)

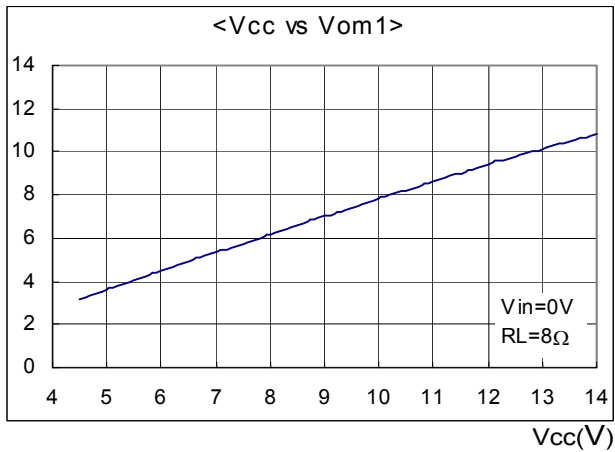

V_{om}(V)

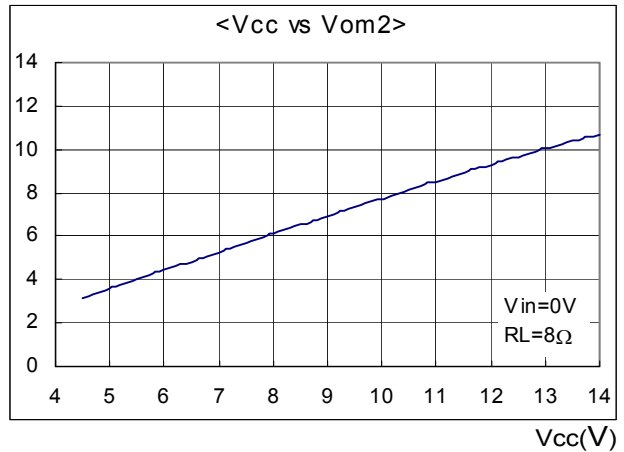

V_{om}(V)

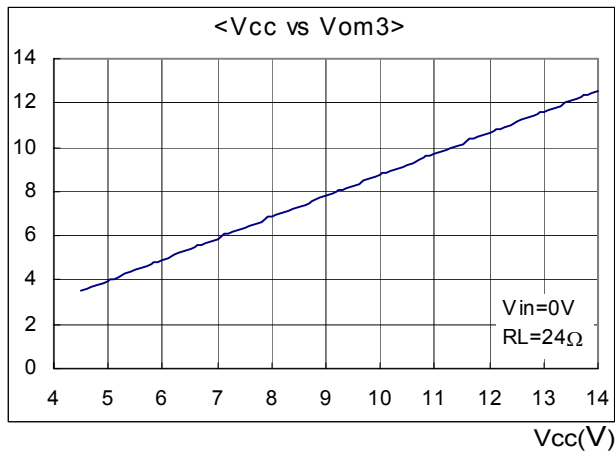

V_{om}(V)

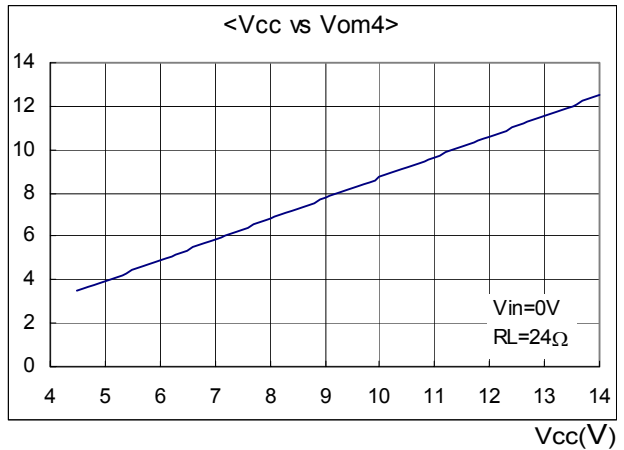

Typical performance characteristics (Continued)

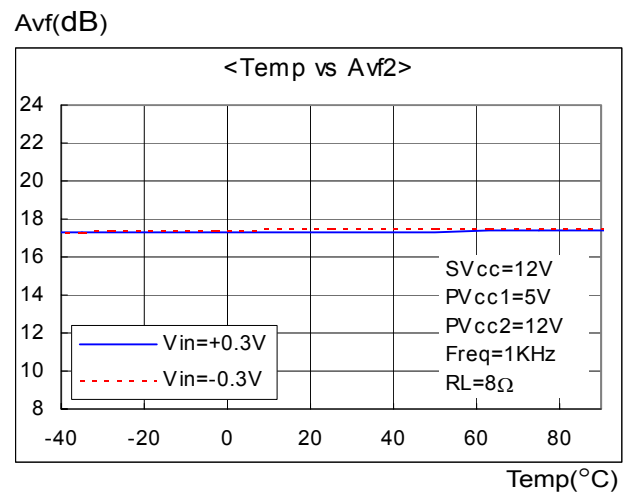
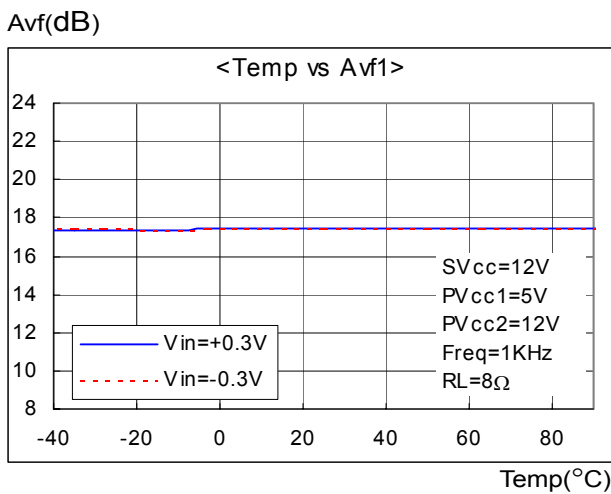
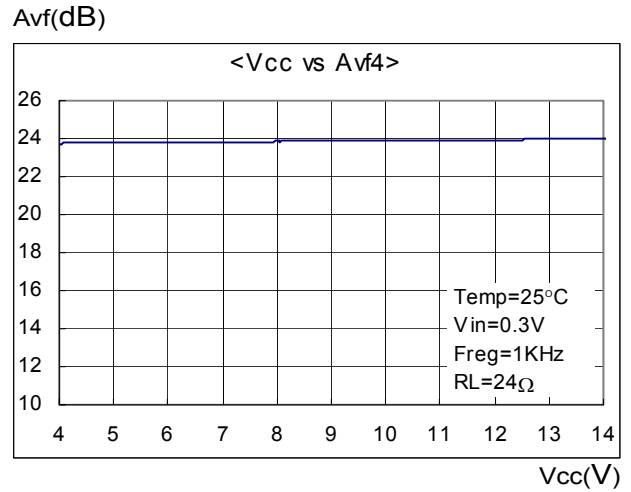
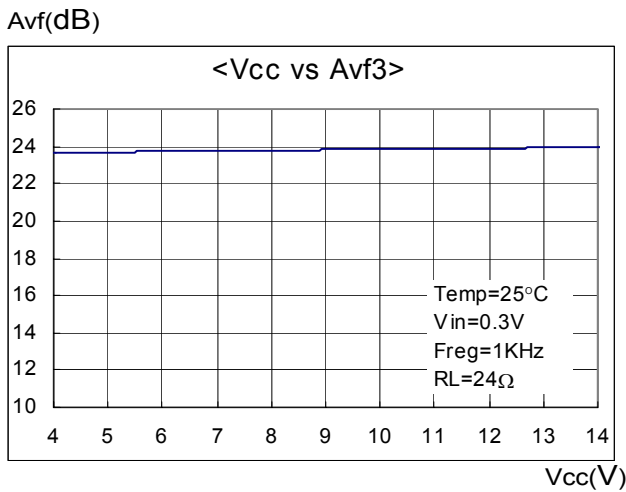
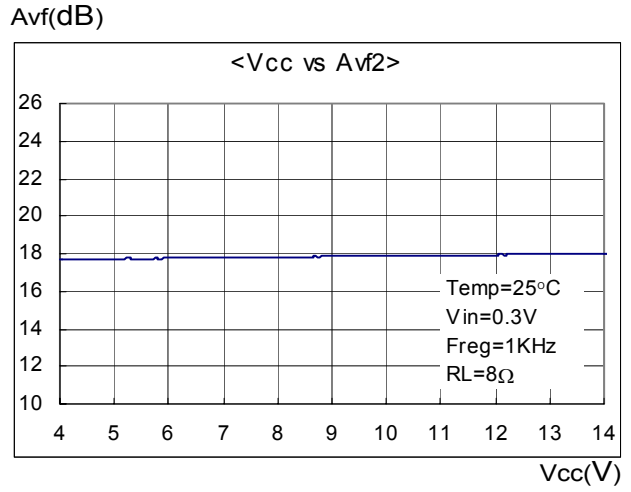
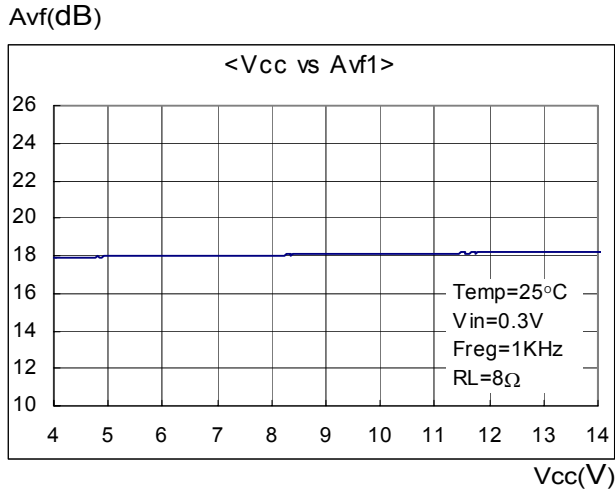

Typical performance characteristics (Continued)

Avf(dB)

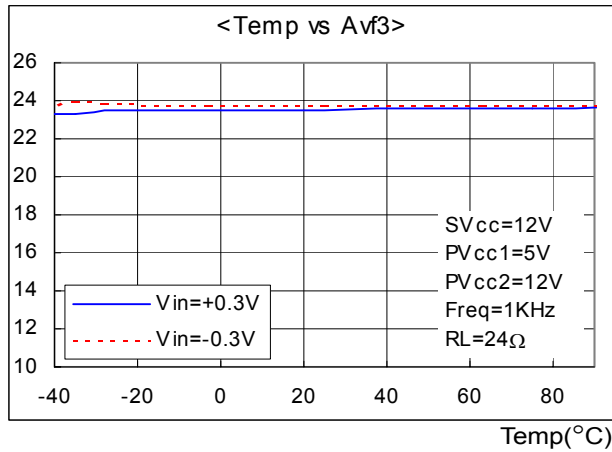

Avf(dB)

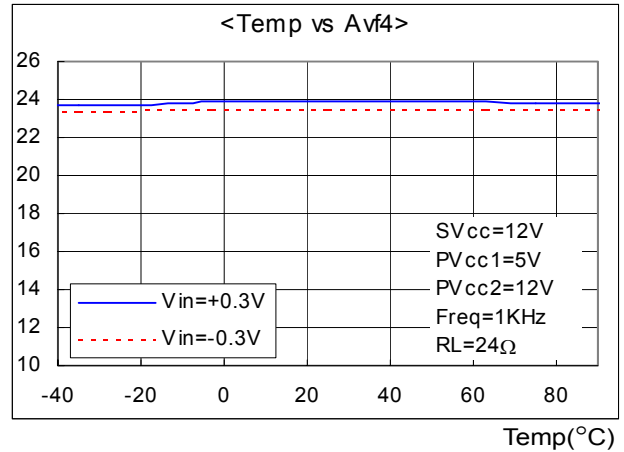

Regulator part

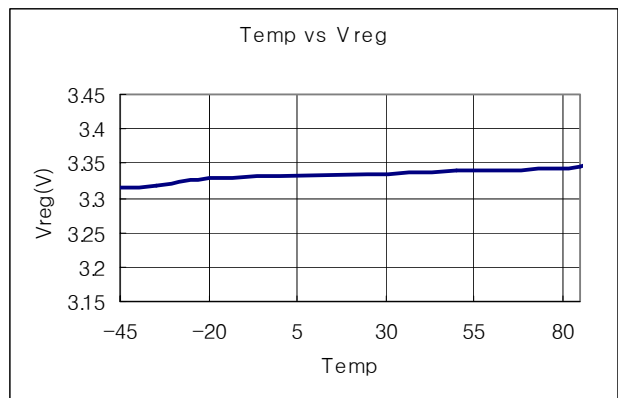
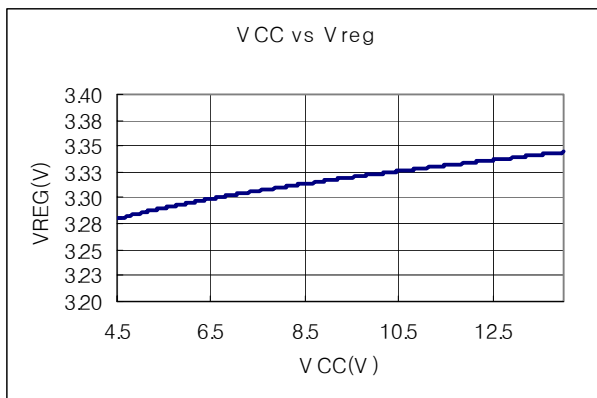

Test circuits

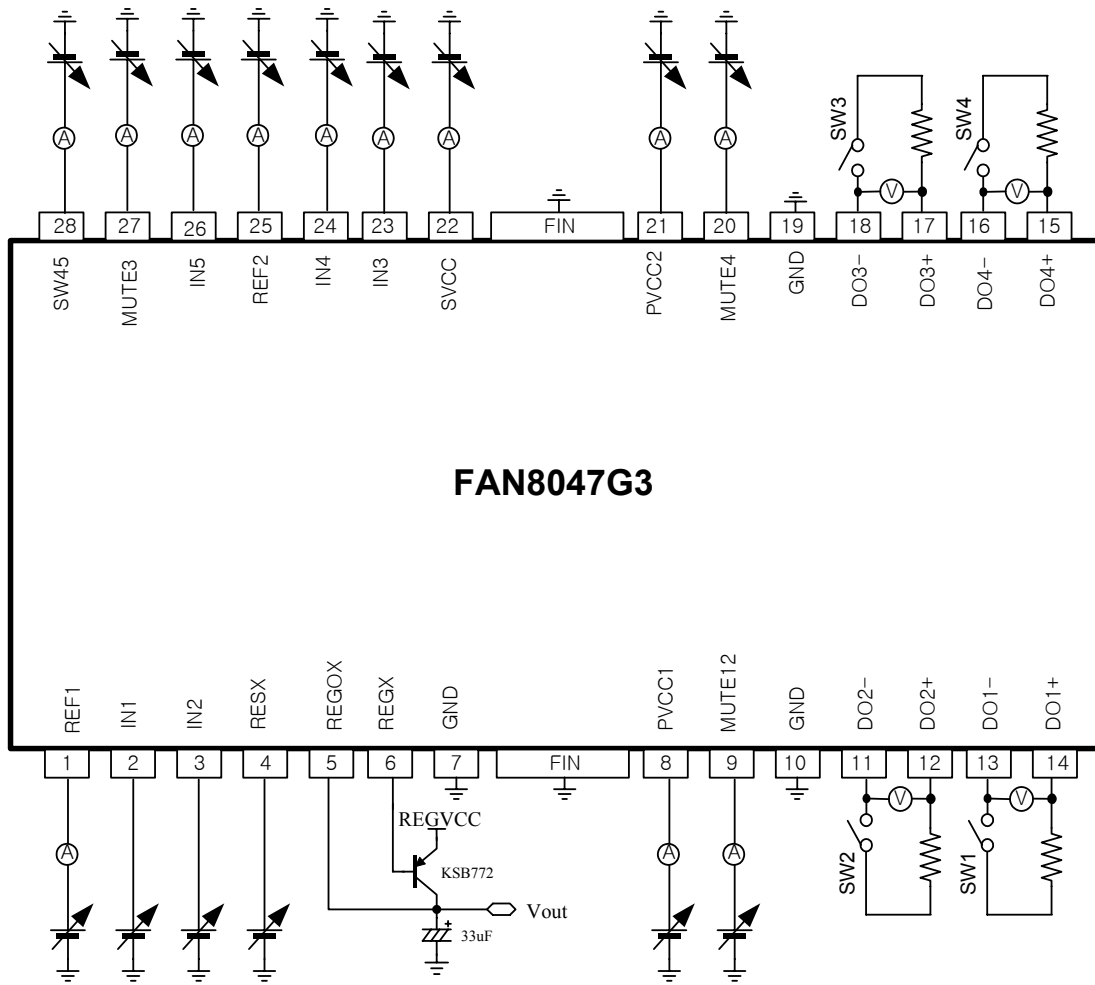

Typical application circuit

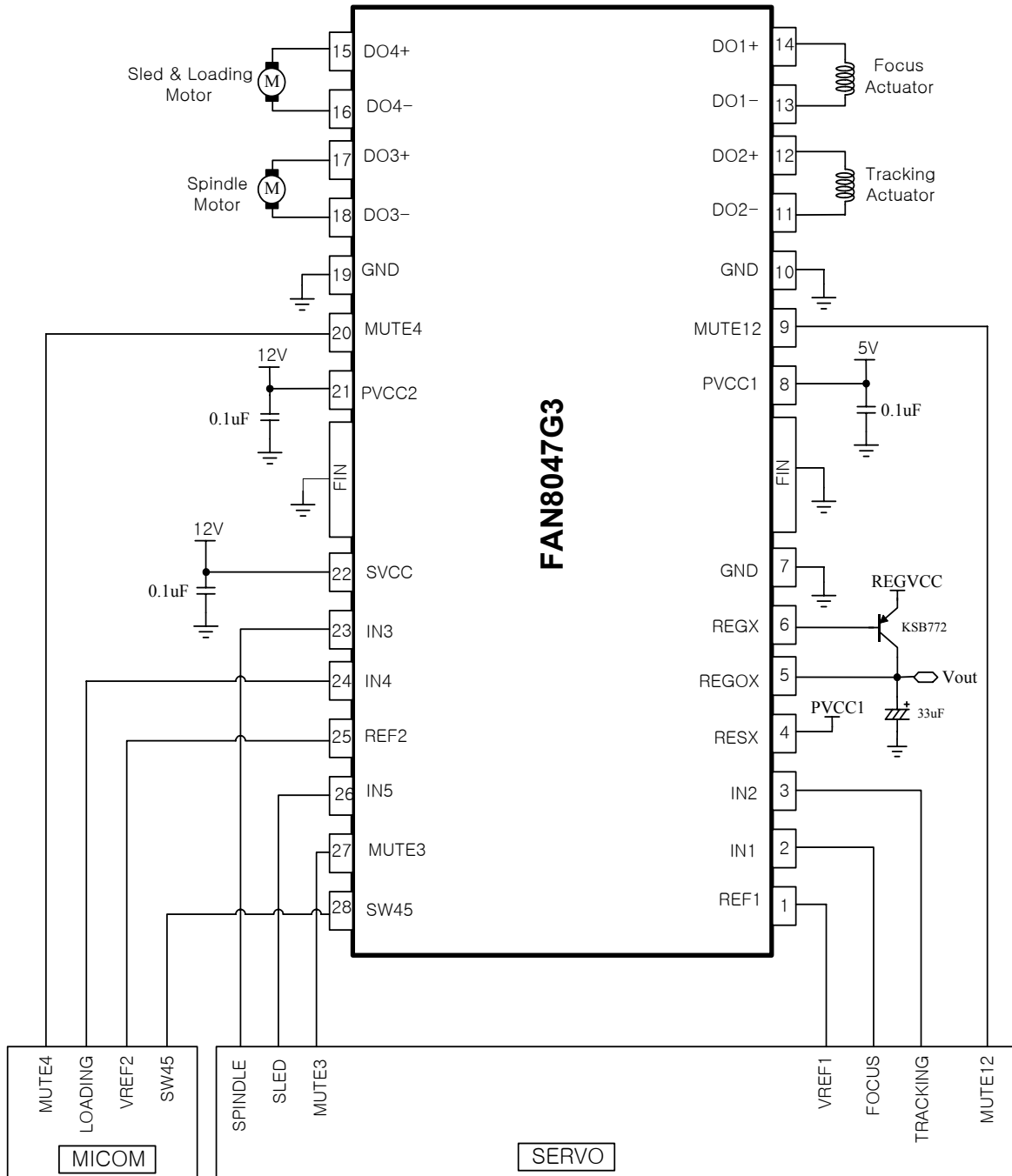

Package dimension

28-SSOPH-375-SG2

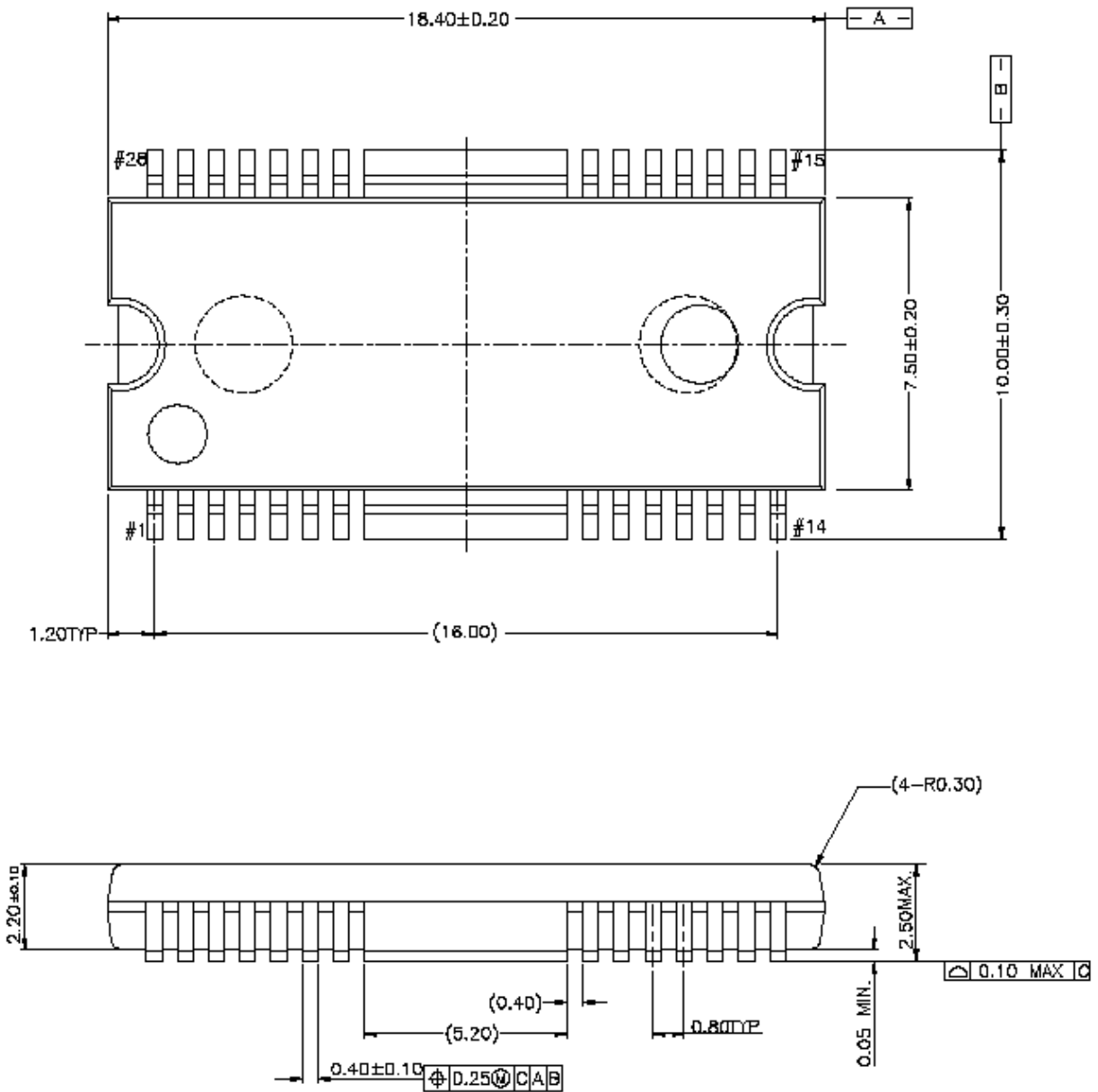

Unit : mm

DISCLAIMER

FAIRCHILD SEMICONDUCTOR RESERVES THE RIGHT TO MAKE CHANGES WITHOUT FURTHER NOTICE TO ANY PRODUCTS HEREIN TO IMPROVE RELIABILITY, FUNCTION OR DESIGN. FAIRCHILD DOES NOT ASSUME ANY LIABILITY ARISING OUT OF THE APPLICATION OR USE OF ANY PRODUCT OR CIRCUIT DESCRIBED HEREIN; NEITHER DOES IT CONVEY ANY LICENSE UNDER ITS PATENT RIGHTS, NOR THE RIGHTS OF OTHERS.

LIFE SUPPORT POLICY

FAIRCHILD'S PRODUCTS ARE NOT AUTHORIZED FOR USE AS CRITICAL COMPONENTS IN LIFE SUPPORT DEVICES OR SYSTEMS WITHOUT THE EXPRESS WRITTEN APPROVAL OF THE PRESIDENT OF FAIRCHILD SEMICONDUCTOR CORPORATION. As used herein:

1. Life support devices or systems are devices or systems which, (a) are intended for surgical implant into the body, or (b) support or sustain life, and (c) whose failure to perform when properly used in accordance with instructions for use provided in the labeling, can be reasonably expected to result in a significant injury of the user.
2. A critical component in any component of a life support device or system whose failure to perform can be reasonably expected to cause the failure of the life support device or system, or to affect its safety or effectiveness.