

# FAN8486D (KA3086D)

## 2-Phase BLDC Motor Driver

### Features

- Drives the BLDC motor using 2 hall sensors.
- 2-phase, full-wave drive method
- Built-in thermal shutdown (TSD) circuit
- Controls the motor speed through voltage
- Built-in bandgap circuit
- Built-in frequency Generator (FG) & Phase Generator (PG) amplifier & comparator.

### Descripton

The FAN8486D is a monolithic integrated circuit, and it is suitable for drum motor driver of VCR system.

28-SSOP-300SG

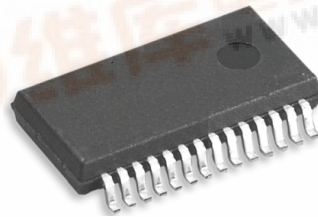

### Typical Applications

- Video cassette recorder (VCR) cylinder (drum) motor
- Other 2-phase BLDC motor

### Ordering Information

Device	Package	Operating Temp.
FAN8486D	28-SSOP-300SG	-25°C ~ +75°C
FAN8486DTF	28-SSOP-300SG	-25°C ~ +75°C

## Pin Assignments

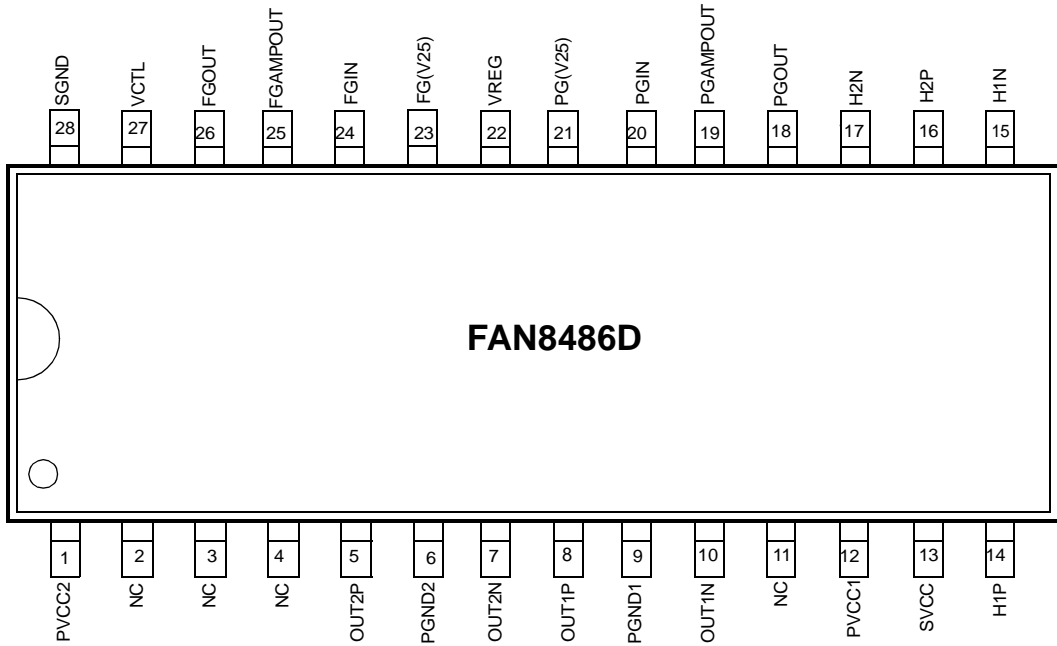

## Pin Definitions

Pine Number	Pin Name	I/O	Pin Function Description
1	PVCC2	-	Power supply voltage2
2	NC	-	-
3	NC	-	-
4	NC	-	-
5	OUT2P	O	Output drive 2(P)
6	PGND2	O	Power ground 2
7	OUT2N	O	Output drive 2(N)
8	OUT1P	O	Output drive 1(P)
9	PGND1	O	Power ground 1
10	OUT1N	-	Output drive 1(N)
11	NC	-	-
12	PVCC1	-	Power supply voltage1
13	SVCC	-	Signal supply voltage
14	H1P	I	Hall signal input 1P
15	H1N	I	Hall signal input 1N
16	H2P	I	Hall signal input 2P
17	H2N	I	Hall signal input 2N
18	PGOUT	O	Phase generate output
19	PGAMP OUT	O	Phase generate amp. output
20	PGIN	I	Phase generate input
21	PG(V25)	-	Reference voltage for PG
22	VREG	-	Regulated voltage
23	FG(V25)	-	Reference voltage for FG
24	FGIN	I	Frequency generate input
25	FGAMP OUT	O	Frequency generate amp. output
26	FGOUT	O	Frequency generate output
27	VCTL	I	Voltage control(motor speed control)
28	SGND	-	Signal ground

# Internal Block Diagram

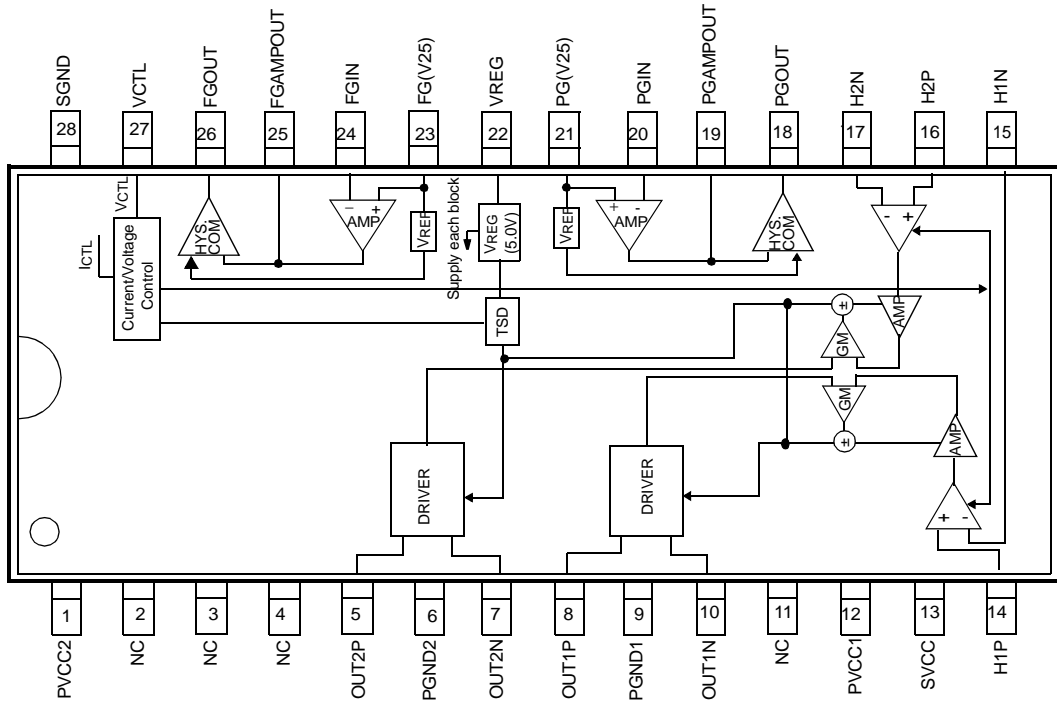

## Equivalent Circuits

Description	Pin No.	Internal circuit
VCTL	27	
Motor output	5,7,8,10	
Hall input	14,15,16,17	

### Equivalent Circuits (Continued)

Description	Pin No.	Internal circuit
PG, FG amplifier	19,20 24,25	
PG, FG hysteresis amplifier	18,19,25,26	

## Absolute Maximum Ratings (Ta=25°C)

Parameter	Symbol	Value	Unit	Remark
Supply voltage	VCCmax	18	V	-
Maximum output current	IOmax	1.0 <sup>note1</sup>	A	-
VREG output current	I <sub>REG</sub> max	30	mA	-
Power dissipation	P <sub>d</sub>	1 <sup>note2</sup>	W	No heat sink
Operating temperature	T <sub>OPR</sub>	-25 ~ +75	°C	-
Storage temperature	T <sub>STG</sub>	-45 ~ +125	°C	-

### Notes:

- Duty 1 / 100, pulse width 500μs
- 1) When mounted on glass epoxy PCB (76.2 × 114 × 1.57mm)  
2) Power dissipation reduces 8.0mW / °C for using above Ta=25°C. (Without heat-sink)  
3) Do not exceed P<sub>d</sub> and SOA(Safe Operating Area).

## Power Dissipation Curve

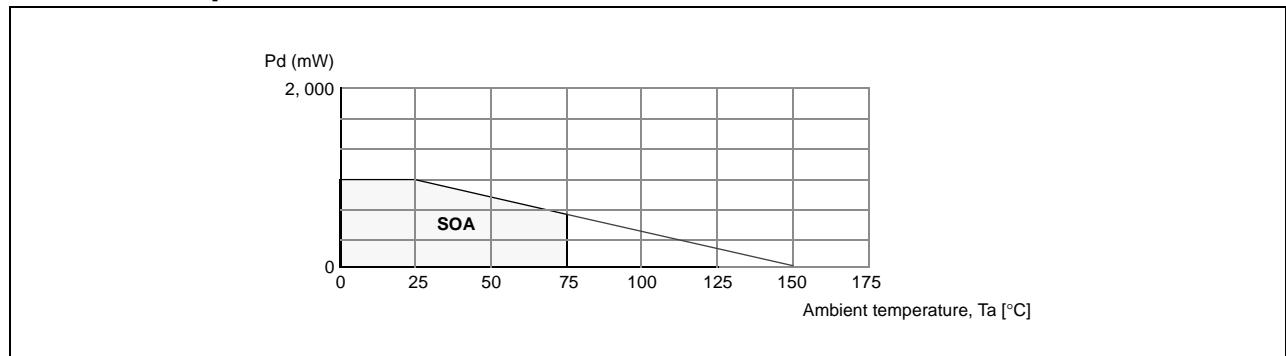

## Recommended Operating Conditions (Ta=25°C)

Parameter	Symbol	Min.	Typ.	Max	Unit
Operating supply voltage	VCC	8	12	16	V

## Electrical Characteristics

( $T_a=25^\circ\text{C}$ ,  $V_{CC}=12\text{V}$ , unless otherwise specified)

Parameter	Symbol	Condition	Min.	Typ.	Max.	Unit
<b>FULL CIRCUIT</b>						
Quiescent current	$I_Q$	$V_{CC}=12\text{V}$	-	8.5	13	mA
<b>VOLTAGE REGULATOR</b>						
Regulated voltage	$V_{REG}$	$V_{CC}=12\text{V}$	4.6	5.0	5.4	V
Regulated voltage	$V_{REG}$	$V_{CC}=12\text{V}$ , $I_{REG}=-20\text{mA}$	4.6	5.0	5.4	V
<b>HALL INPUT</b>						
Hall minimum input level <sup>note</sup>	$V_{INH}$	-	50	-	-	mVp-p
Hall bias current	$I_{BH}$	$V_{CTL}=2.0\text{V}$ , Hall=2.5V	-	0.25	2.0	$\mu\text{A}$
<b>OUTPUT DIRVE</b>						
Output saturation voltage (Upper)	$V_{SU}$	$V_{CTL}=4.5\text{V}$	-	1.3	2.0	V
Output saturation voltage (Lower)	$V_{SL}$	$V_{CTL}=4.5\text{V}$	-	2.0	2.0	V
Output current A	$I_{OUTA}$	$V_{H1P}=2.6\text{V}$ $V_{HALL\_1N}=2.4\text{V}$ , $V_{CTL}=3.5\text{V}$	500	700	900	mA
Output current B	$I_{OUTB}$	$V_{H2P}=2.6\text{V}$ $V_{H2N}=2.4\text{V}$ , $V_{CTL}=2.5\text{V}$	500	700	900	mA
<b>VOLTAGE CONTROL</b>						
$V_{CTL}$ reference voltage <sup>note</sup>	$V_{25}$	$0.48 \times V_{REG}$	2.0	2.3	2.5	V
$V_{CTL}$ input range <sup>note</sup>	$V_{CTL}$	-	0	-	$V_{REG}$	V
$V_{CTL}$ offset range	$V_{OFF}$	$V_{CTL}=0 \sim V_{CTL}$	-150	0	+150	mV
$V_{CTL}$ input bias current	$I_{VCTL}$	$V_{CTL}=2.5\text{V}$	-	1.0	6.0	$\mu\text{A}$
Voltage control gain	$G_M$	$V_{CTL}=2.8\text{V}$ , $3.3\text{V}$ $\Delta I_O / \Delta V_{CTL}$ $V_{H1P}=2.6\text{V}$ , $V_{H1N}=2.4\text{V}$				
			0.38	0.55	0.64	A / V

### NOTE:

The note in the chart means items calculated and approved in design not the items proven by actual test result.



## Electrical Characteristics (Continued)

(Ta=25°C, VCC=12V, unless otherwise specified)

Parameter	Symbol	Condition	Min.	Typ.	Max.	Unit
<b>FULL CIRCUIT</b>						
Shutdown temperature <sup>note</sup>	TSD	-	130	160	-	°C
Temperature hysteresis <sup>note</sup>	THYS	-	-	30	-	°C
<b>FG / PG AMP</b>						
Input offset voltage	VOFS	-	-	0	± 8	mV
Input current	IAMP_IN	VIN=2.5V	-	0.2	2.0	μA
Open loop gain <sup>note</sup>	GA	VCC=12V, Signal=500Hz	65	70	-	dB
Output high voltage	VOHA	VIN=2.0V	VREG -1.48	VREG -0.74	-	V
Output low voltage	VOLA	VIN=2.7	-	0.85	1.45	V
<b>COMPARATOR (HYSTERESIS)</b>						
Hysteresis level	VHYS	-	±130	±165	±200	mV
Output low voltage	VOLHYS	VIN=2.0V	-	0.12	0.32	V
Output pull-up resistance	VBHYS	-	7.0	10	13	kΩ

**NOTE:**

The note in the chart means items calculated and approved in design not the items proven by actual test result.

## Application Informations

### 1. A Diagram Summarizing The Entire System

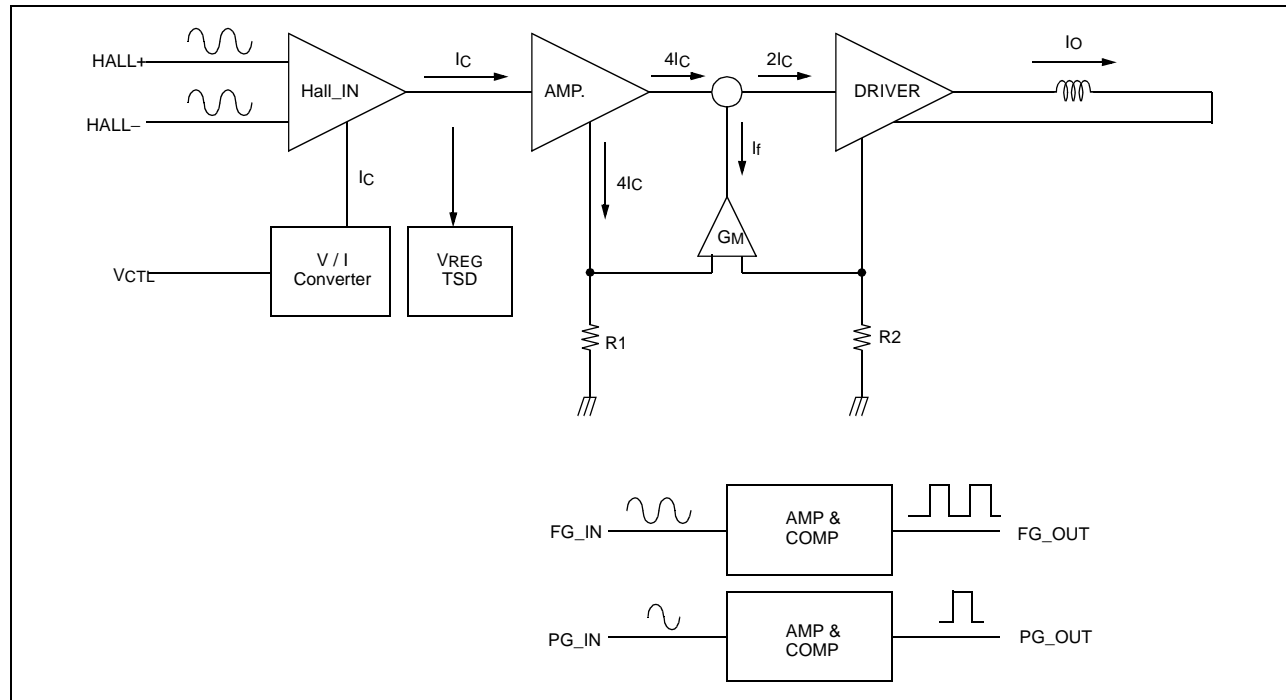

Figure 1.

Figure 1 is a conceptual diagram of the FAN8486D. It turns on or off depending on the signal of the hall sensor used for sensing the rotor position of motor.

The AMP, GM (Feedback) and output blocks are circuits used to determine current gain of FAN8486D.

Furthermore, HallIN represents the hall signal switch.

It supplies stable bias to each VREG block. The TSD block is a thermal shutdown circuit that protects the IC during an high temperature inside the IC.

Moreover, FG. and PG. blocks output individual signals generated in the motor using the amplifier and comparator.

These signals transmit motor speed and position data to controller of external servo etc. for their control.

### 2. Current Control

Figure 2 simplifies figure 1.

The supplied  $I_O$  current drives the motor and the  $I_c$  current controls the motor speed.

Figure 3 is a graph of  $I_{CTL}$  vs.  $I_O$ .

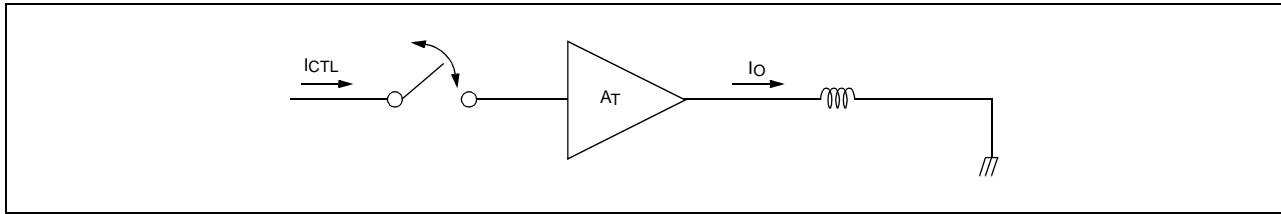

Figure 2.

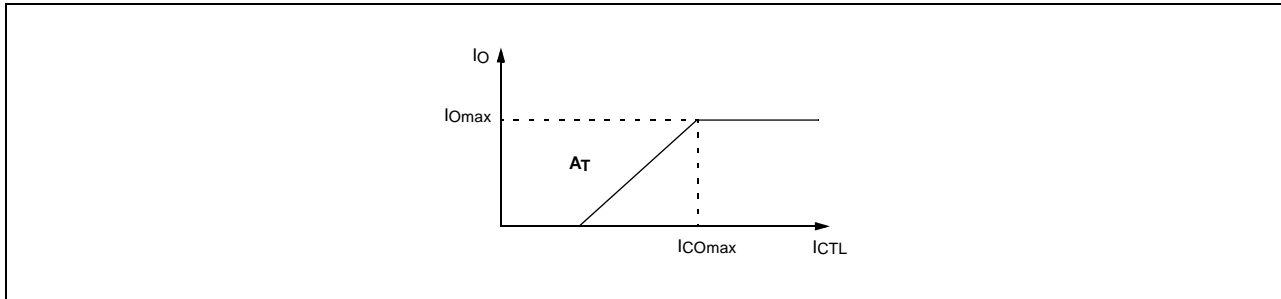

Figure 3.

### 3. Voltage Control

Even though FAN8486D command uses  $I_c$  to control the magnitude of  $I_O$ , it can also use voltage. FAN8486D mainly uses voltage control and has option to use current control.

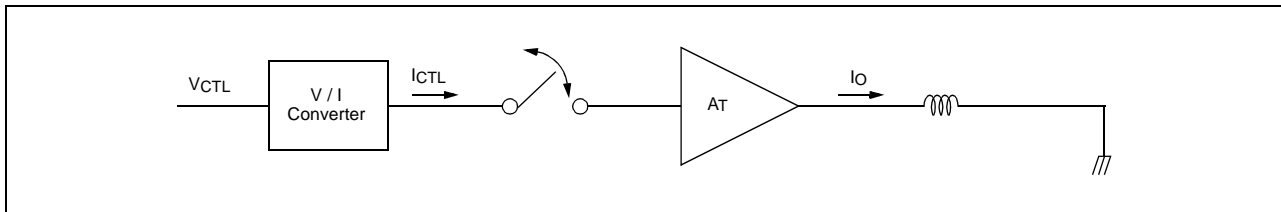

Figure 4.

Figure 4 shows the principle of the voltage control.

The  $V_{CTL}$  is the motor speed control voltage, and the  $I_{CTL}$  is converted to current through the  $V / I$  converter.

Figure 5 shows the graph of  $V_{CTL}$  vs.  $I_O$ .

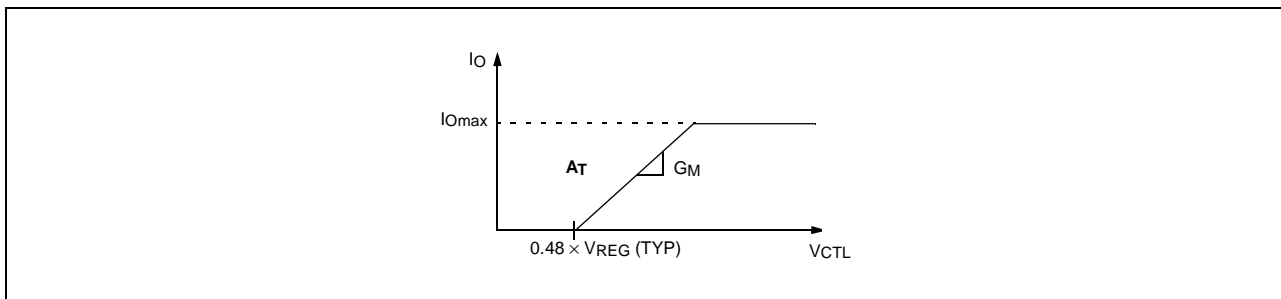
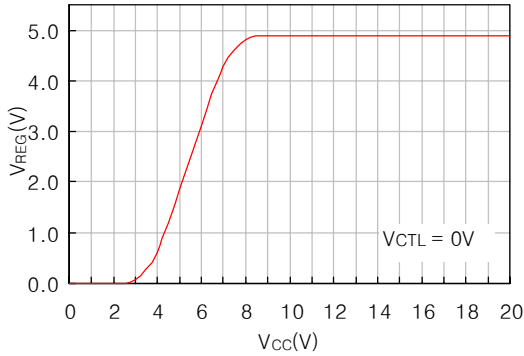
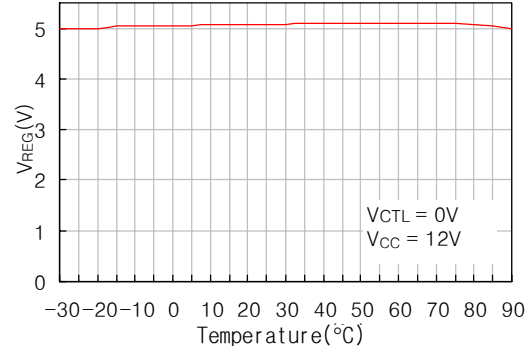

Figure 5.

## Typical Performance Characteristics



1.  $V_{CC}$  vs  $V_{REG}$



2. Temp. vs  $V_{REG}$

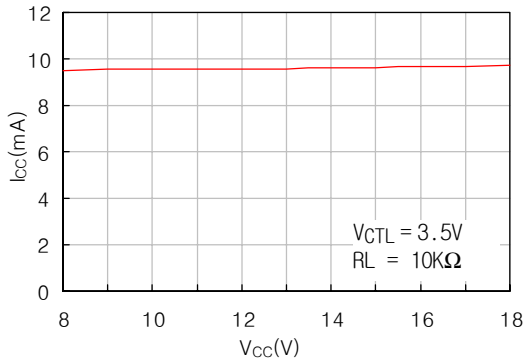

3.  $V_{CC}$  vs  $I_{CC}$

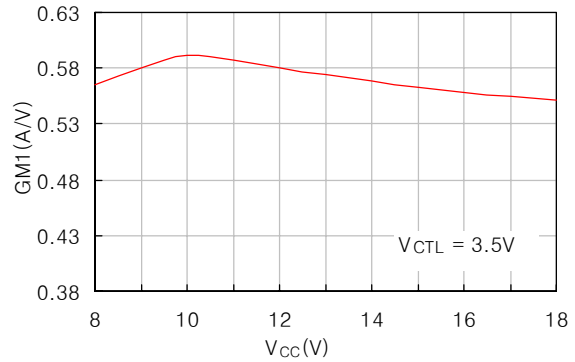

4.  $V_{CC}$  vs  $GM1$

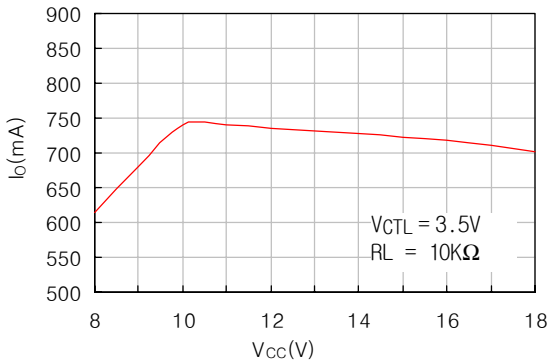

5.  $V_{CC}$  vs  $I_{OA}$

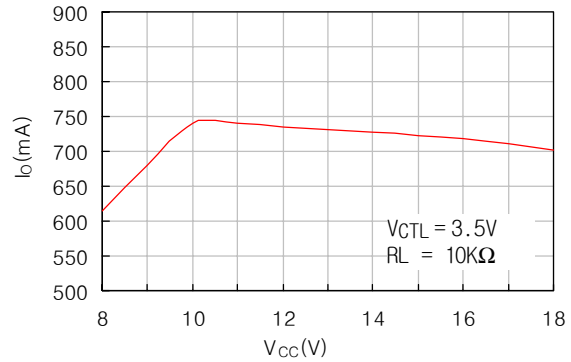

6.  $V_{CC}$  vs  $I_{OB}$

# Test Circuits

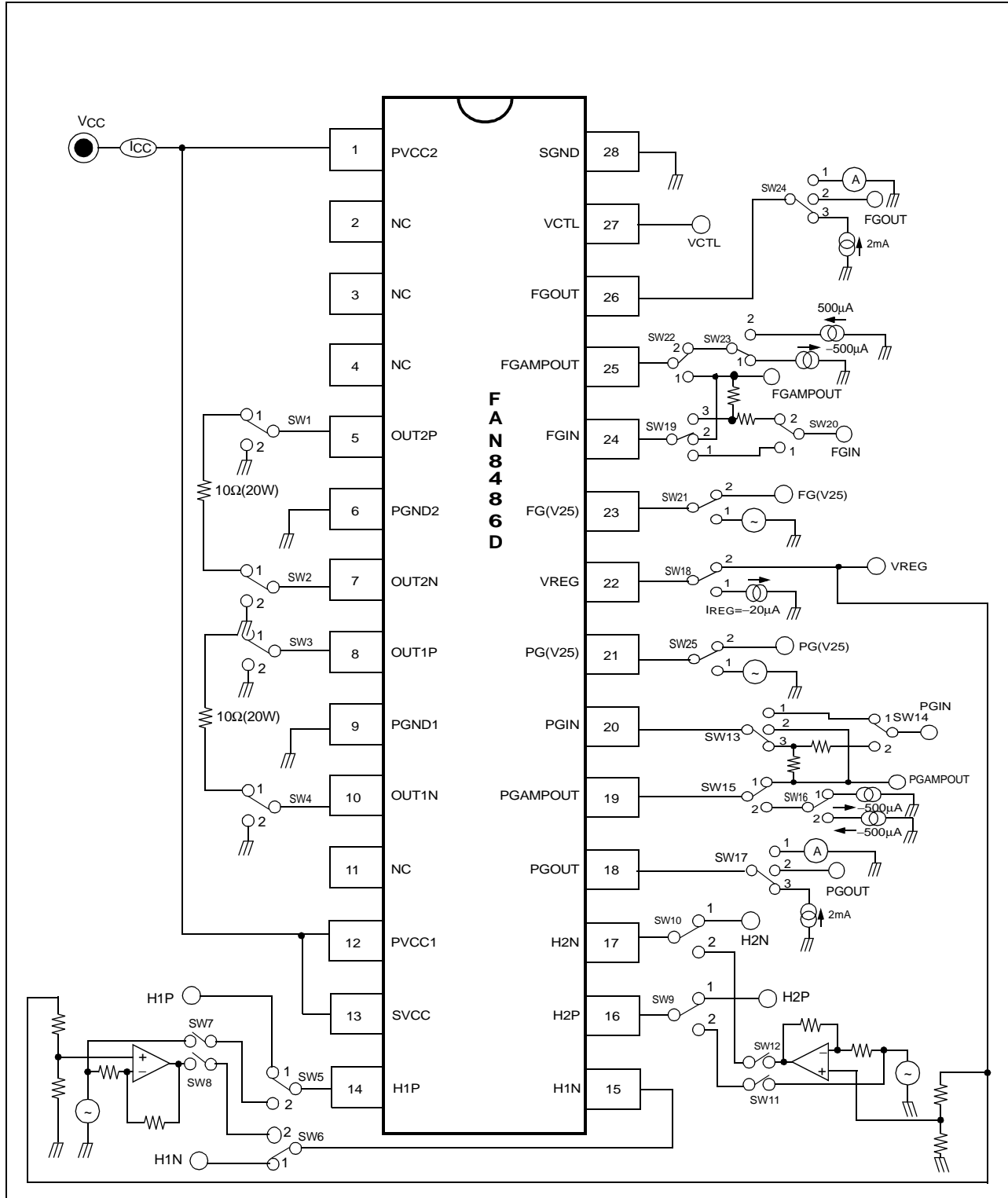

## Typical Application Circuits

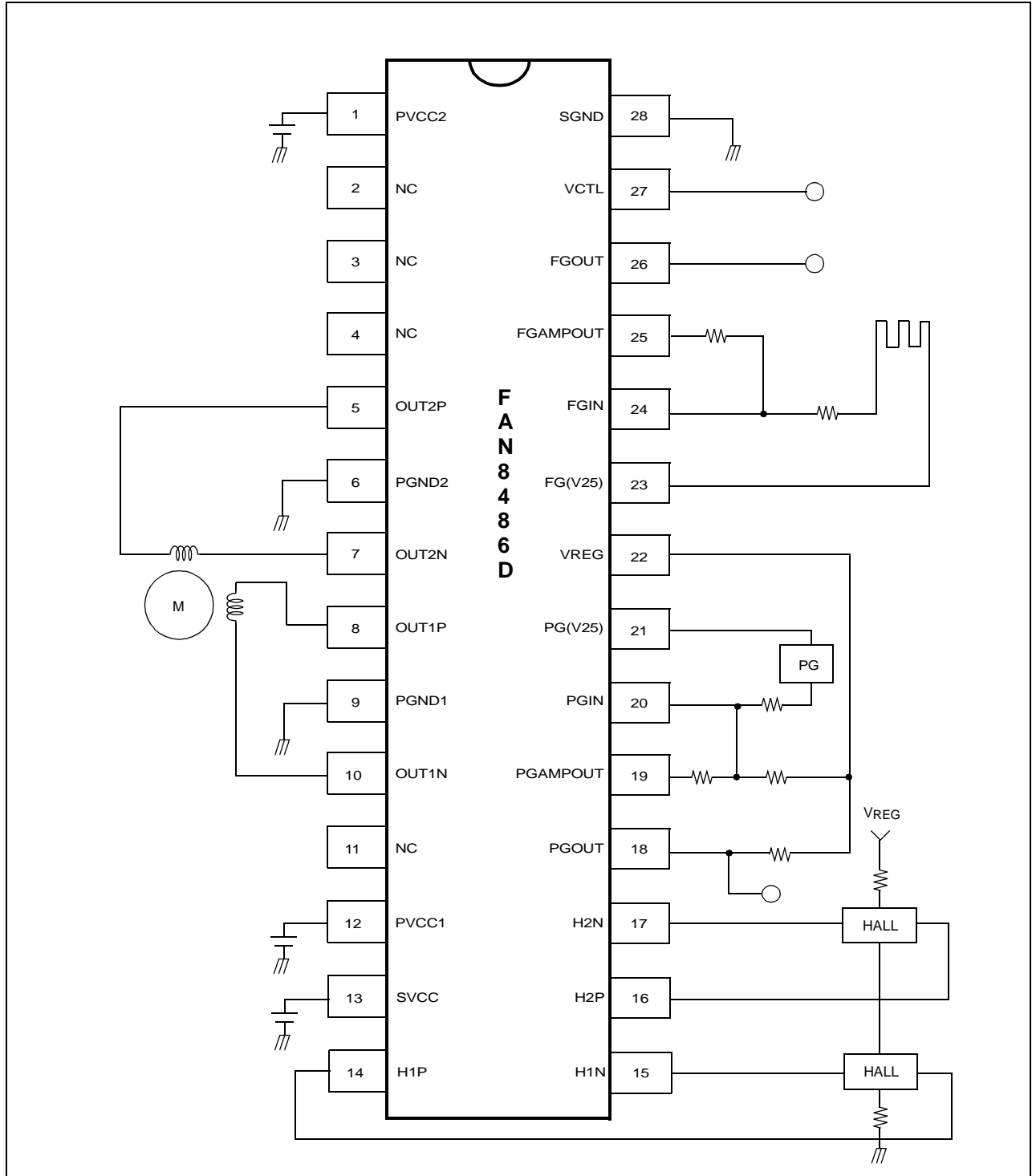



**DISCLAIMER**

FAIRCHILD SEMICONDUCTOR RESERVES THE RIGHT TO MAKE CHANGES WITHOUT FURTHER NOTICE TO ANY PRODUCTS HEREIN TO IMPROVE RELIABILITY, FUNCTION OR DESIGN. FAIRCHILD DOES NOT ASSUME ANY LIABILITY ARISING OUT OF THE APPLICATION OR USE OF ANY PRODUCT OR CIRCUIT DESCRIBED HEREIN; NEITHER DOES IT CONVEY ANY LICENSE UNDER ITS PATENT RIGHTS, NOR THE RIGHTS OF OTHERS.

**LIFE SUPPORT POLICY**

FAIRCHILD'S PRODUCTS ARE NOT AUTHORIZED FOR USE AS CRITICAL COMPONENTS IN LIFE SUPPORT DEVICES OR SYSTEMS WITHOUT THE EXPRESS WRITTEN APPROVAL OF THE PRESIDENT OF FAIRCHILD SEMICONDUCTOR INTERNATIONAL. As used herein:

1. Life support devices or systems are devices or systems which, (a) are intended for surgical implant into the body, or (b) support or sustain life, and (c) whose failure to perform when properly used in accordance with instructions for use provided in the labeling, can be reasonably expected to result in a significant injury of the user.
2. A critical component in any component of a life support device or system whose failure to perform can be reasonably expected to cause the failure of the life support device or system, or to affect its safety or effectiveness.