

FAN8725 (KA3025)

Spindle Motor and 5-Channel Motor Driver

Features

Common

- Built-in thermal shutdown circuit (TSD)
- Built-in power save circuit
- 3 Independent voltage source
- Corresponds to 3.3V or 5V DSP

Spindle

- Built-in hall bias
- Built-in FG signal output circuit
- Built-in rotational direction detecting circuit
- Built-in protection circuit for reverse rotation
- Built-in short brake circuit

BTL (5-channel)

- Built-in 5-CH balanced transformerless (BTL) driver
- Built-in Level shift circuit
- Independent voltage sources
- VM2 = CH1,CH2 / VM3 = CH3, CH4 ,CH5

Typical Applications

- Compact disk ROM (CD-ROM)
- Compact disk RW (CD-RW)
- Digital video disk ROM (DVD-ROM)
- Digital video disk RAM (DVD-RAM)
- Digital video disk Player (DVDP)
- Other compact disk media

Description

The FAN8725 is a monolithic IC suitable for a 3-phase BLDC spindle motor driver and 5-ch motor drivers which drives the focus actuator, tracking actuator, loading motor, stepping motor driver of the CD-media systems.



Ordering Information

Device	Package	Operating Temp.
FAN8725	48-QFPH-1414	-35°C ~ +85°C

Pin Assignments

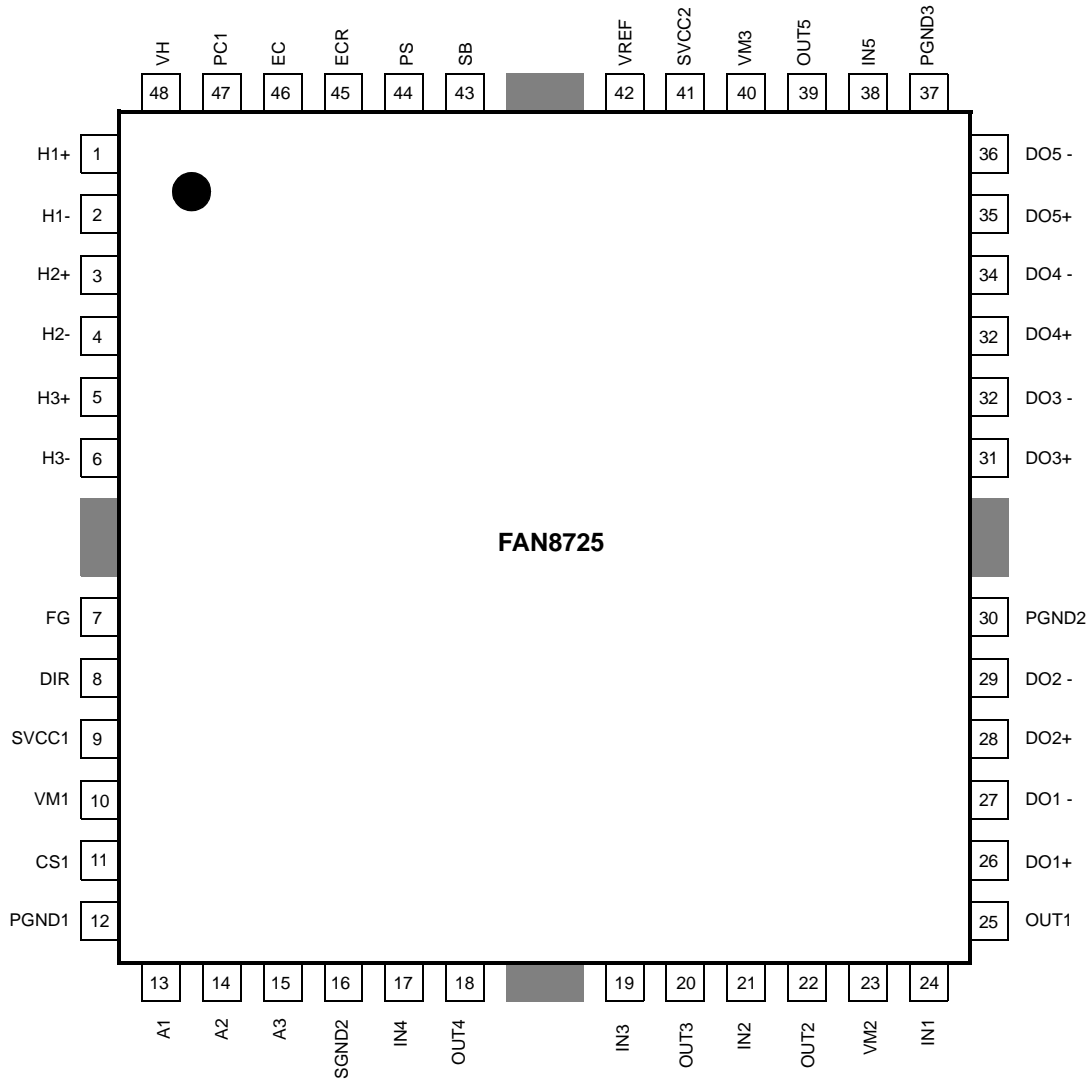

Pin Definitions

Pin Number	Pin Name	I/O	Pin Function Description
1	H1-	I	Hall 1(-) input
2	H1+	I	Hall 1(+) input
3	H2+	I	Hall 2(-) input
4	H2-	I	Hall 2(+) input
5	H3+	I	Hall 3(-) input
6	H3-	I	Hall 3(+) input
7	FG	O	Frequency Generator output
8	DIR	O	Rotation direction output
9	SVCC1	-	Spindle Signal supply voltage
10	VM1	-	Spindle power supply
11	CS1	I	Spindle current sense
12	PGND1	-	Spindle power ground
13	A1	O	3-phase output1
14	A2	O	3-phase output2
15	A3	O	3-phase output3
16	SGND2	-	CH signal ground
17	IN4	I	OP-Amp CH 4 input(-)
18	OUT4	O	OP-Amp CH 4 output
19	IN3	I	OP-Amp CH 3 input(-)
20	OUT3	O	OP-Amp CH 3 output
21	IN2	I	OP-Amp CH 2 input(-)
22	OUT2	O	OP-Amp CH 2 output
23	VM2	-	CH1/CH2 power supply
24	IN1	I	OP-Amp CH 1 input(-)
25	OUT1	O	OP-Amp CH 1 output
26	DO1+	O	Channel 1 output (+)
27	DO1 -	O	Channel 1 output (-)
28	DO2+	O	Channel 2 output (+)
29	DO2 -	O	Channel 2 output (-)
30	PGND2	-	CH1/CH2 power ground
31	DO3+	O	Channel 3 output (+)
32	DO3 -	O	Channel 3 output (-)
33	DO4+	O	Channel 4 output (+)

Pin Definitions (Continued)

Pin Number	Pin Name	I/O	Pin Function Description
34	DO4 -	O	Channel 4 output (-)
35	DO5+	O	Channel 5 output (+)
36	DO5-	O	Channel 5 output (-)
37	PGND3	-	CH3/CH4/CH5 power ground
38	IN5	I	OP-Amp CH 5 input(-)
39	OUT5	O	OP-Amp CH 5 output
40	VM3	-	CH3/CH4/CH5 power supply
41	SVCC2	-	CH Signal supply voltage
42	VREF	I	BTL reference voltage
43	SB	I	Short brake
44	PS	I	Power save
45	ECR	I	Torque control reference
46	EC	I	Torque control
47	PC1	-	Phase compensation capacitor
48	VH	I	Hall bias

Notes:

BTL drive part symbol(+,- outputs of drives) is determined according to the polarity of input pin.
(For example, if the voltage of pin 24 is high, the output of pin 26 is high)

Internal Block Diagram

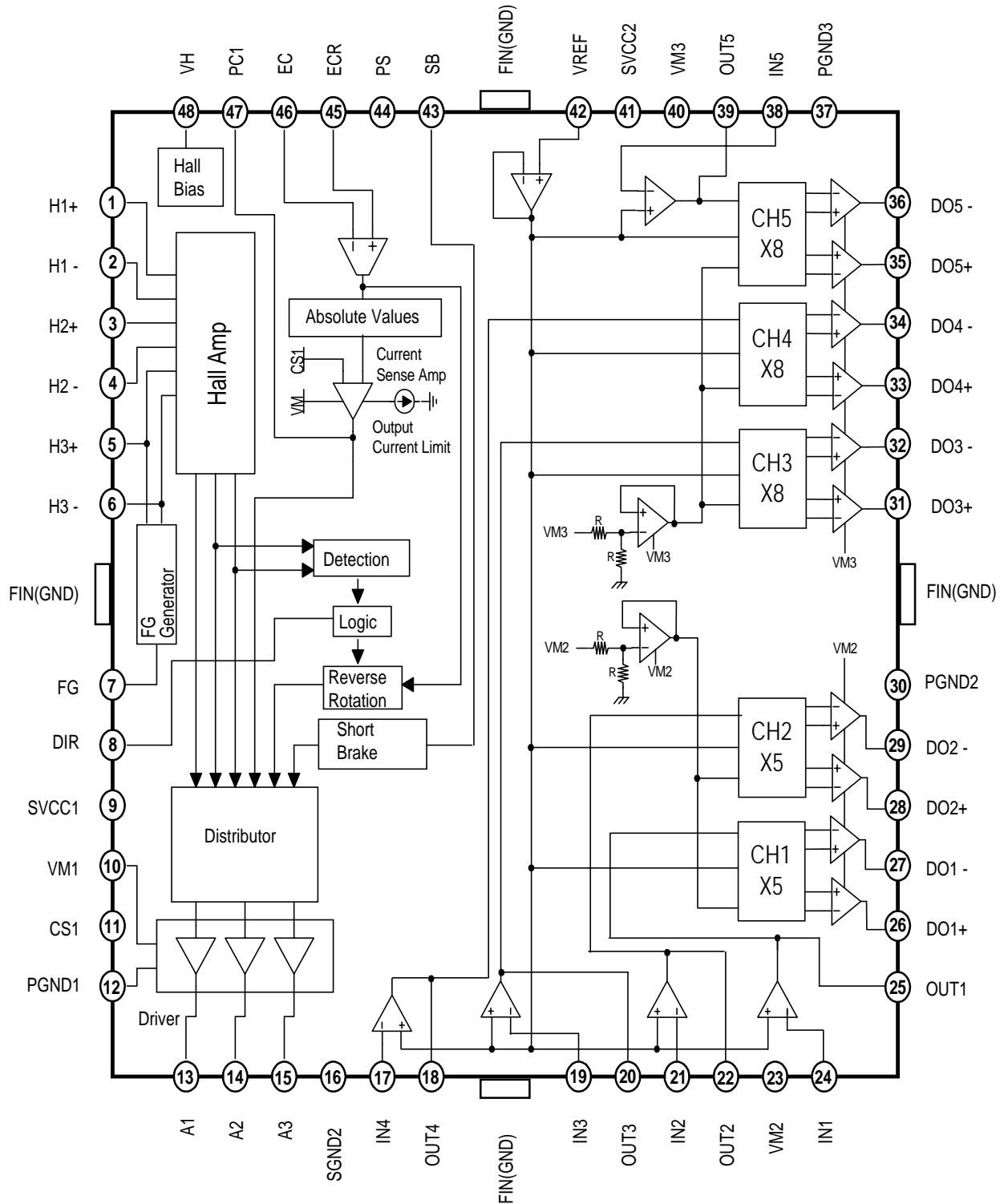

Equivalent Circuits (Spindle Part)

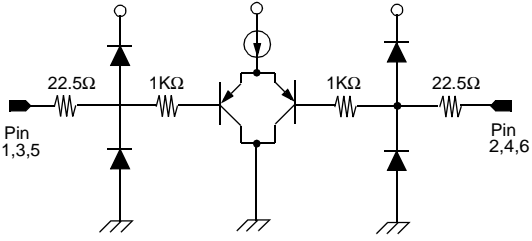
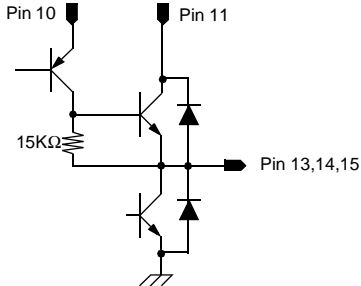
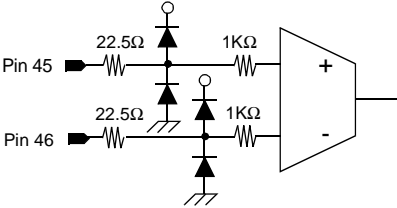
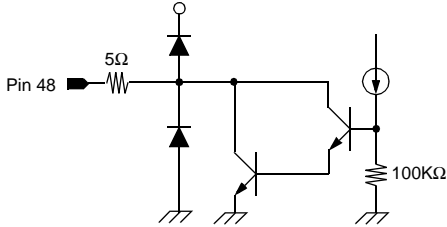
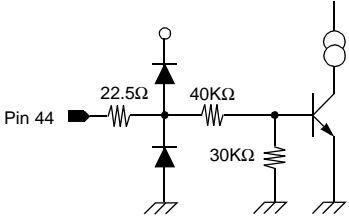
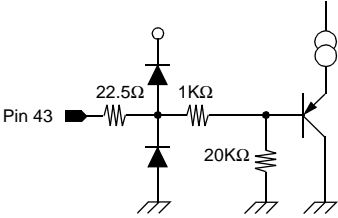
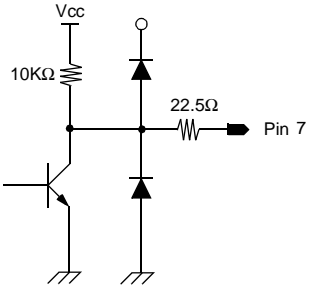
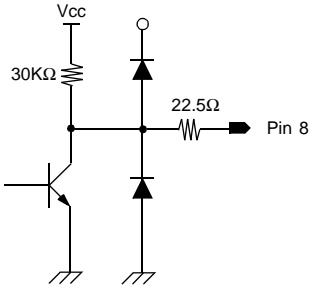
HALL INPUT	DRIVER OUTPUT
	
TORQUE CONTROL INPUT	HALL BIAS INPUT
	
POWER SAVE INPUT	SHORT BRAKE INPUT
	
FG OUTPUT	DIR OUTPUT
	

Equivalent Circuits (BTL Part)

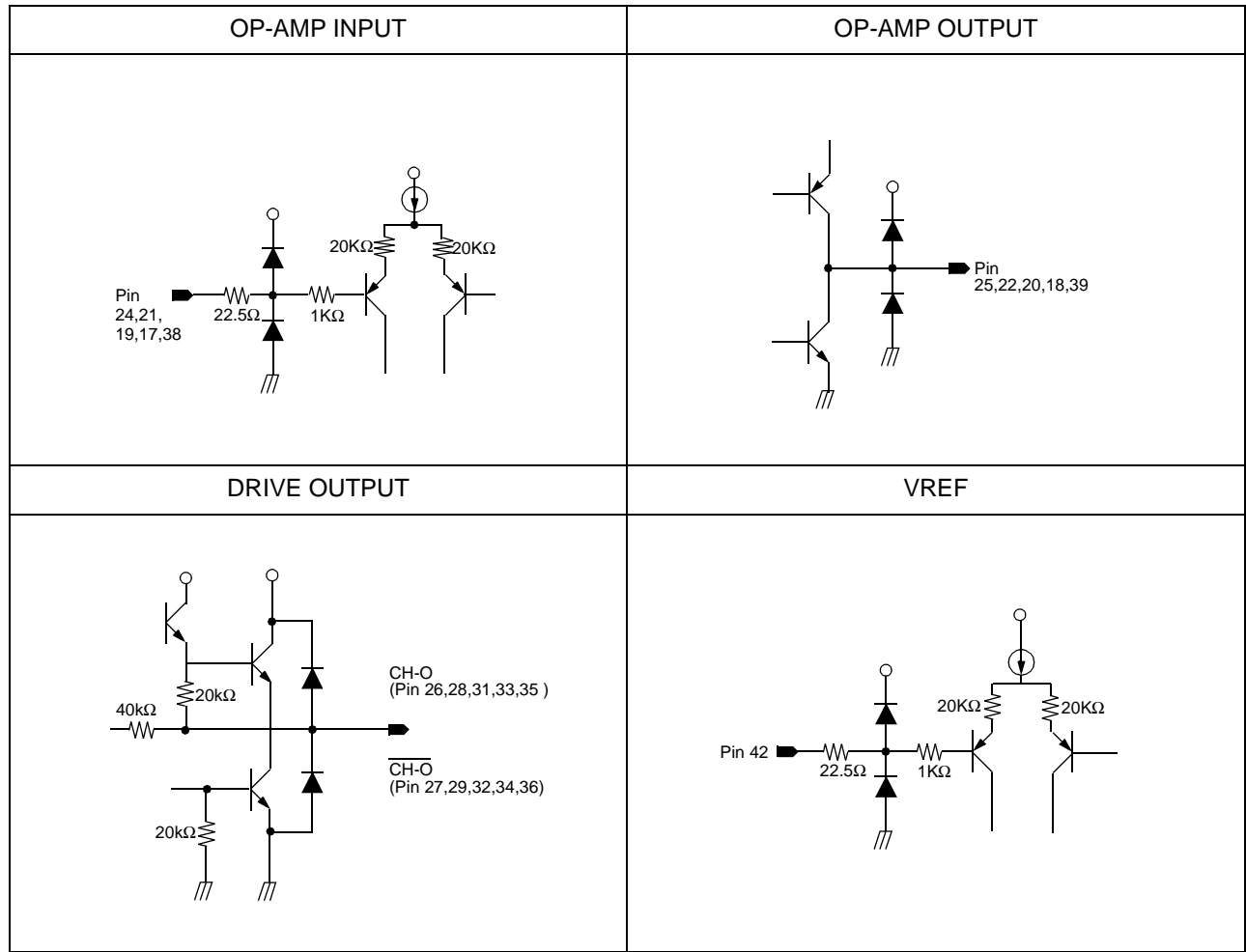

Absolute Maximum Ratings (Ta = 25°C)

Parameter	Symbol	Value	Unit
Supply Voltage (Spindle Signal)	SVCC1max	7	V
Supply Voltage (BTL Signal)	SVCC2max	15	V
Supply Voltage (Spindle Motor)	VM1max	15	V
Supply Voltage (BTL CH1/2)	VM2max	15	V
Supply Voltage (BTL CH3/4/5)	VM3max	15	V
Power dissipation	PD	3.0 ^{note}	W
Operating Temperature Range	TOPR	-35 ~ +85	°C
Storage temperature Range	TSTG	-55 ~ +150	°C
Maximum Output Current (Spindle)	IOmaxa	1.3	A
Maximum Output Current (BTL)	IOmaxb	0.6	A

NOTE:

- When mounted on 70mm × 70mm × 1.6mm PCB (Phenolic resin material)
- Power dissipation is reduced 24mW/°C for using above Ta=25°C
- Do not exceed PD and SOA (Safe Operating Area)

Power Dissipation Curve

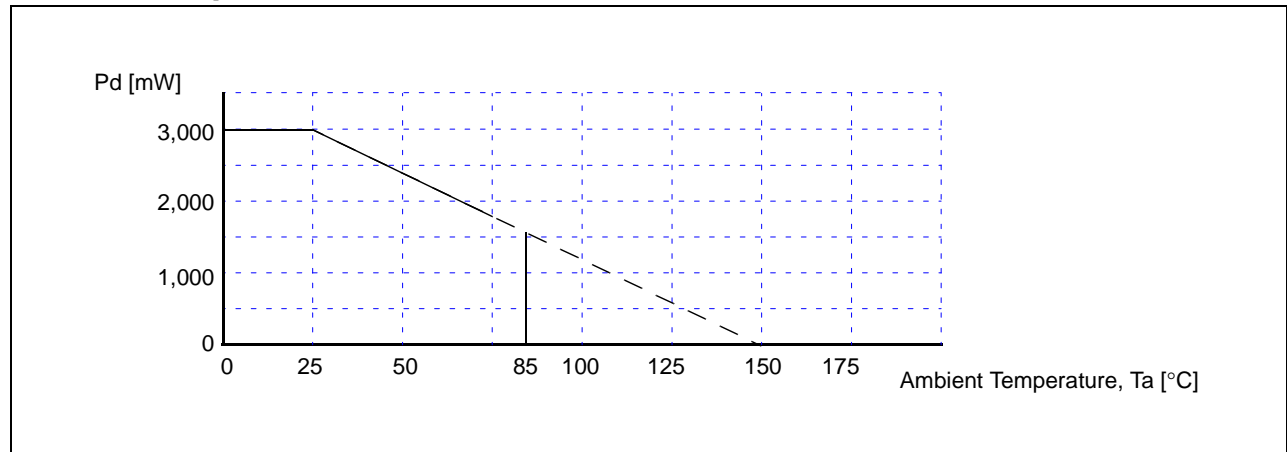

Recommended Operating Conditions (Ta = 25°C)

Parameter	Symbol	Min.	Typ.	Max.	Unit
Operating Supply Voltage (Spindle Signal)	SVCC1	4.5	–	5.5	V
Operating Supply Voltage (BTL Signal)	SVCC2	10.8	–	13.2	V
Operating Supply Voltage (Spindle Motor)	VM1	10.8	–	13.2	V
Operating Supply Voltage (BTL CH1/2)	VM2	4.5	–	SVCC2	V
Operating Supply Voltage (BTL CH3/4/5)	VM3	4.5	–	SVCC2	V

Electrical Characteristics (Ta = 25°C)

Parameter	Symbol	Condition	Min.	Typ.	Max.	Units
FULL CHIP						
Quiescent Circuit Current 1	I _{CC1}	FULL CHIP (PS=0V)	–	0	0.2	mA
Quiescent Circuit Current 2	I _{CC2}	SPINDLE (PS=5V)	–	5	10	mA
Quiescent Circuit Current 3	I _{CC3}	BTL (PS=5V)	–	20	30	mA
POWER SAVE						
On Voltage Range	V _{PSon}	L-H Circuit On	2.5	–	V _{CC}	V
Off Voltage Range	V _{PSoff}	H-L Circuit Off	–	–	1.0	V
HALL BIAS						
Hall Bias Voltage	V _{HB}	I _{HB} =20mA	0.4	1.0	1.8	V
HALL AMP						
Hall Bias Current	I _{HA}	-	–	0.5	2	uA
Common Mode Input Range	V _{HAR}	-	1.5	–	4.0	V
Minimum in Level	V _{INH}	-	100	–	–	mVpp
H1 Hysteresis	V _{HYS}	-	5	20	40	mVpp
TORQUE CONTROL						
Ecr In Voltage Range	E _{CR}	-	0.2	–	4.0	V
Ec In Voltage Range	E _C	-	0.2	–	4.0	V
Offset Voltage (-)	E _{Coff-}	E _C =1.9V	-80	-50	-20	mV
Offset Voltage (+)	E _{Coff+}	E _{CR} =1.9V	20	50	80	mV
E _C In Current	E _{Cin}	E _C =1.9V	-3	-0.5	–	uA
E _{CR} In Current	E _{CRin}	E _{CR} =1.9V	-3	-0.5	–	uA
In/output Gain	G _{EC}	E _{CR} =2.5V, R _{Cs} =0.5Ω	0.56	0.70	0.84	A / V
FG						
FG Output Voltage (H)	V _{FGh}	I _{FG} = -10uA	4.5	4.9	V _{CC}	V
FG Output Voltage (L)	V _{FGl}	I _{FG} =10uA	–	–	0.5	V
Duty(Reference Value)		R _{Cs} =0.5Ω		50		%
OUTPUT BLOCK						
Saturation Voltage (upper TR)	V _{Oh}	I _O = -300mA	–	1.0	1.4	V
Saturation Voltage (lower TR)	V _{Ol}	I _O =300mA	–	0.4	0.7	V
Torque Limit Current	I _{TL}	R _{Cs} =0.5Ω	560	700	840	mA
DIRECTION DETECTOR						
DIR Output Voltage (H)	V _{DIRh}	I _{FG} =-10uA	4.5	4.7		V
Dir Output Voltage (L)	V _{DIRl}	I _{FG} =10uA	–	–	0.5	V
SHORT BRAKE						
On Voltage Range	V _{SBon}	-	2.5	–	V _{CC}	V
Off Voltage Range	V _{SBoff}	-	0	–	1.0	V

ELECTRICAL CHARACTERISTICS (continued)

BTL Drive Part (Ta=25°C, SVCC2=12V, VM2=5V, VM3=12V, RL=8, 24Ω)

Parameter	Symbol	Condition	Min.	Typ.	Max.	Units
CH1/CH2						
Output Offset Voltage1,2	V _{OF1/2}	-	-95	-	95	mV
Maximum Output Voltage1,2	V _{OM1/2}	VM2=5V,RL=8Ω	3.6	4.0	-	V
Voltage Gain	G _{VC1/2}	V _{IN} =0.1Vrms, 1kHz	12.0	14.0	16.0	dB
CH3/CH4/CH5						
Output Offset Voltage3,4,5	V _{OF3/4/5}	-	-95	-	95	mV
Maximum Output Voltage3,4,5	V _{OM3/4/5}	VM3=12V,RL=24Ω	8.4	10.5	-	V
Voltage Gain	G _{VC3/4/5}	V _{IN} =0.1Vrms, 1kHz	16.0	18.0	20.0	dB
OP-AMP CIRCUIT						
Common Mode Input Range	V _{ICM}	-	0	-	11.0	V
Input Bias Current	I _B	-	-300	-30		nA
Low Level Output Voltage	V _{CL}	-	-	0.2	0.5	V
High Level Output Voltage	V _{OH}	-	10.0	11	-	V
Output Driving Source Current	I _{SOURCE}	-	1	4.0	-	mA
Output Driving Sink Current	I _{SINK}	-	5	10	-	mA

Application Information

1. TORQUE CONTROL & OUTPUT CURRENT CONTROL

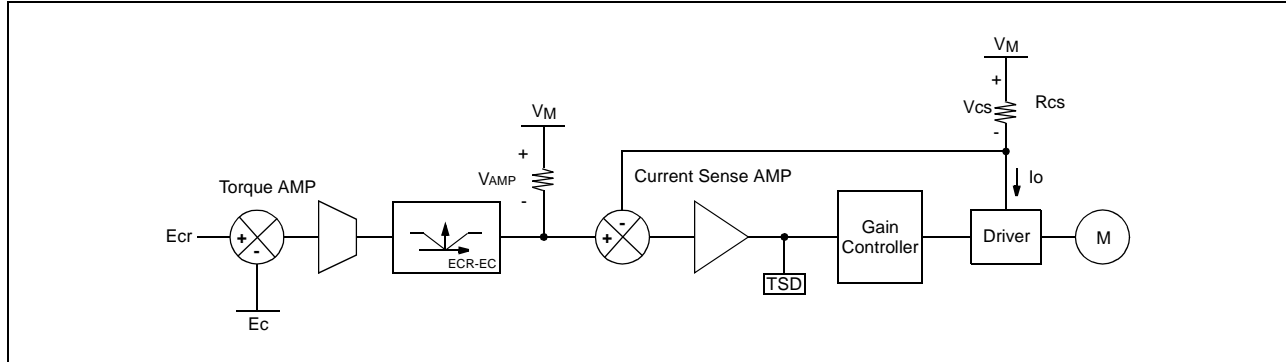

- 1) By amplifying the voltage difference between E_c and E_{cr} from Servo IC, the Torque Sense AMP produces the input voltage (V_{AMP}) for the Current Sense AMP.
- 2) The output current (I_O) is converted into the voltage (V_{CS}) through the sense resistor (R_{CS}) and compared with the V_{AMP} . By the negative feedback loop, the sensed output voltage, V_{CS} is equal to the input V_{AMP} . The output current (I_O) is linearly controlled by the input V_{AMP} .
- 3) The signals, E_C and E_{CR} can control the velocity of the Motor by controlling the output current (I_O) of the Driver.
- 4) The range of the torque voltage is as shown below.

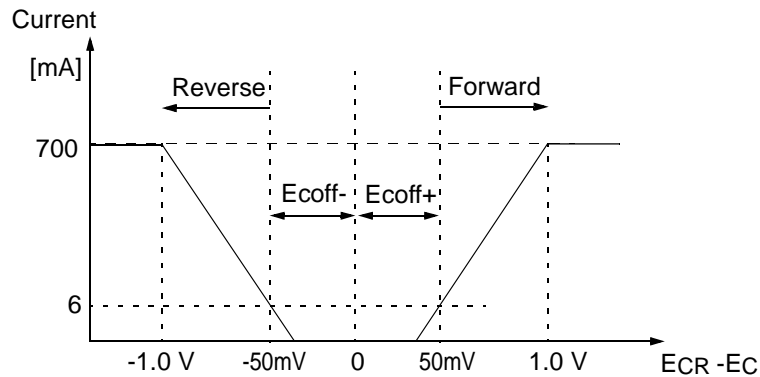

	Rotation
$E_{CR} > E_c$	Forward rotation
$E_{CR} < E_c$	Stop after detecting reverse rotation

The input range of E_{CR} , E_C is 0.2 V ~ 4.0 V ($R_{CS} = 0.5[\Omega]$)

2. SHORT BRAKE

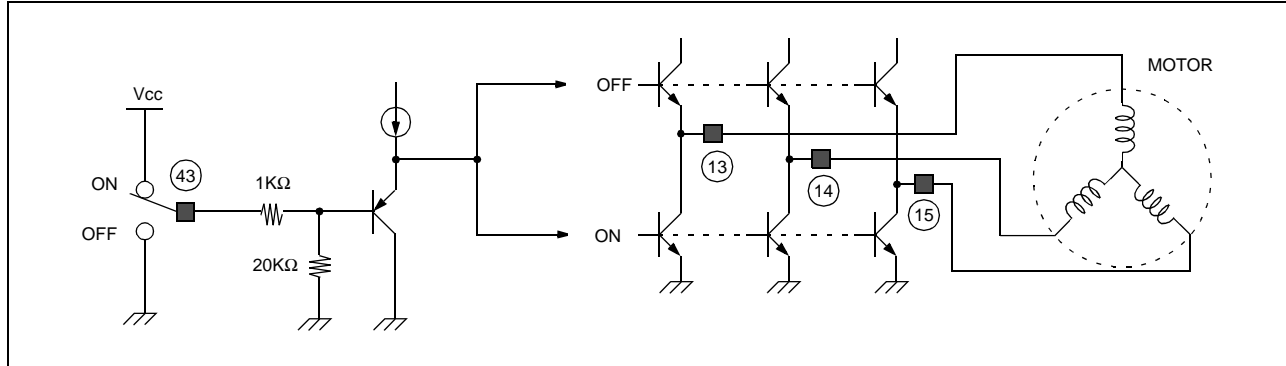

Pin # 43	Short Brake
HIGH	ON
LOW	OFF

When the pick-up mechanism moves from the inner to the outer spindle of the CD, the Brake function of the reverse voltage is commonly employed to decrease the rotating velocity of the Spindle Motor.

However, if the Spindle Motor rotates rapidly, the Brake function of the reverse voltage may produce much heat at the Drive IC.

To enhance the braking efficiency, the Short Brake function is added to FAN8725. When the Short Brake function is activated, all upper Power TRs turn off and all lower Power TRs turn on, so as to make the rotating velocity of the motor slow down. But FG and DIR functions continue to operate normally.

3. POWER SAVE

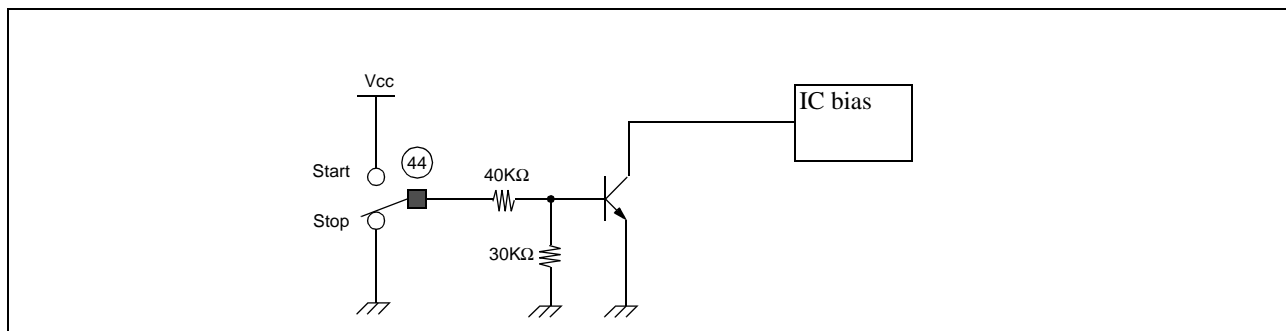

Pin # 44	Power Save
HIGH	Motor Drive Output Activated
LOW	Sleep mode

When PowerSave(PS) function is activated, the chip is deactivated.

4. TSD (THERMAL SHUTDOWN)

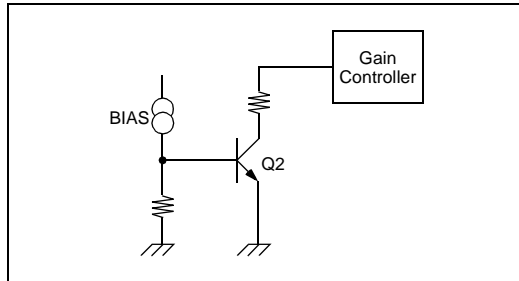

When the chip temperature rises up to about 175C(degree), the Q2 turns on and the output driver shuts down. When the chip temperature falls off to about 150C(degree), then the Q2 turns off and the driver operates normally. TSD has the temperature hysteresis of about 25C(degree).

- The TSD circuit shuts down all the power drives(spindle and BTL power drives) excluding both CH1 and CH2 power drives(actuator part).

5. ROTATIONAL DIRECTION DETECTION

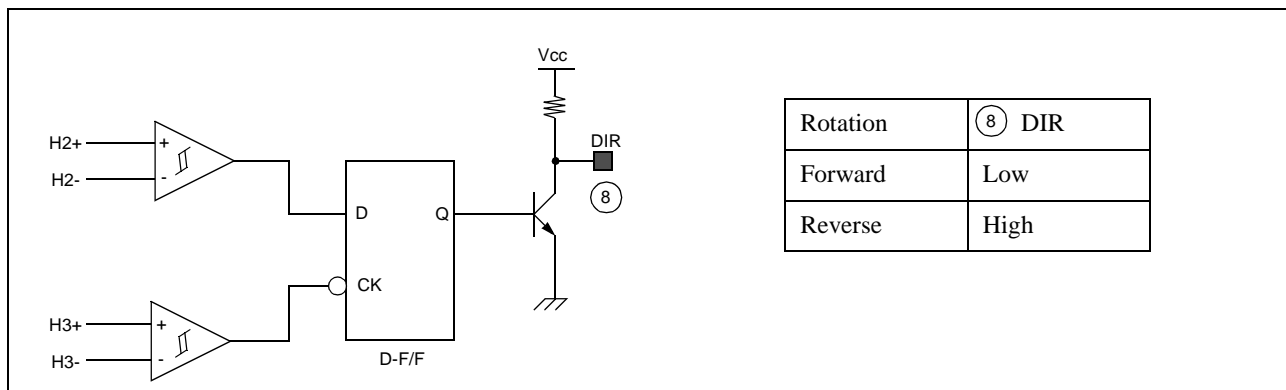

- 1) The forward and the reverse rotations of the CD are detected by using the D-F/F and the truth table is shown in the above.
- 2) The rotational direction of the CD can be explained by the output waveform of the Hall sensors. Let the three outputs of Hall sensors be H1, H2 and H3 respectively. When the spindle rotates in reverse direction, the Hall sensor output waveform are shown in Fig.(a). Thus the phases ordered in H1→H2→H3 with a 120° phase difference.

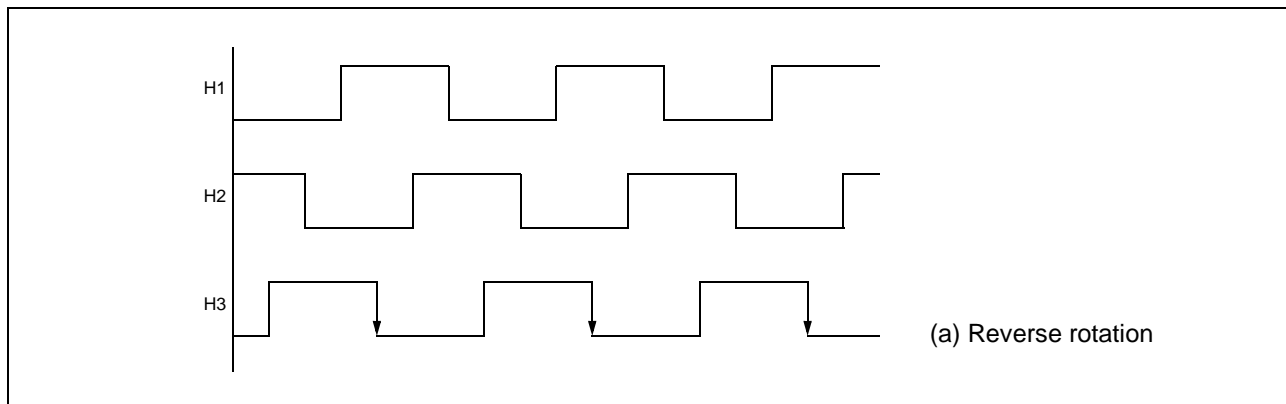

On the other hand, if the spindle rotates in forward rotation, the phase relationship is H3->H2->H1 as shown in Fig.(b)

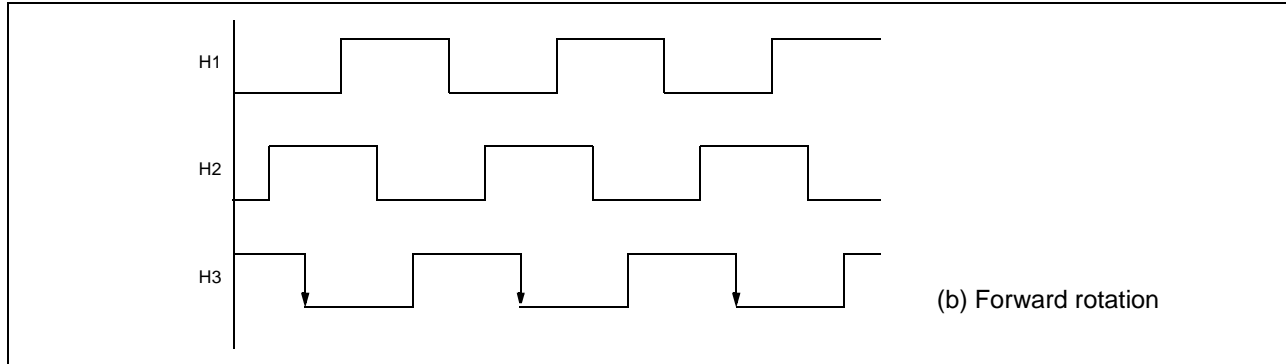

The direction output ,detector is Low, when the spindle rotates forward, and HIGH in the reverse direction.

6. REVERSE ROTATION PREVENTION

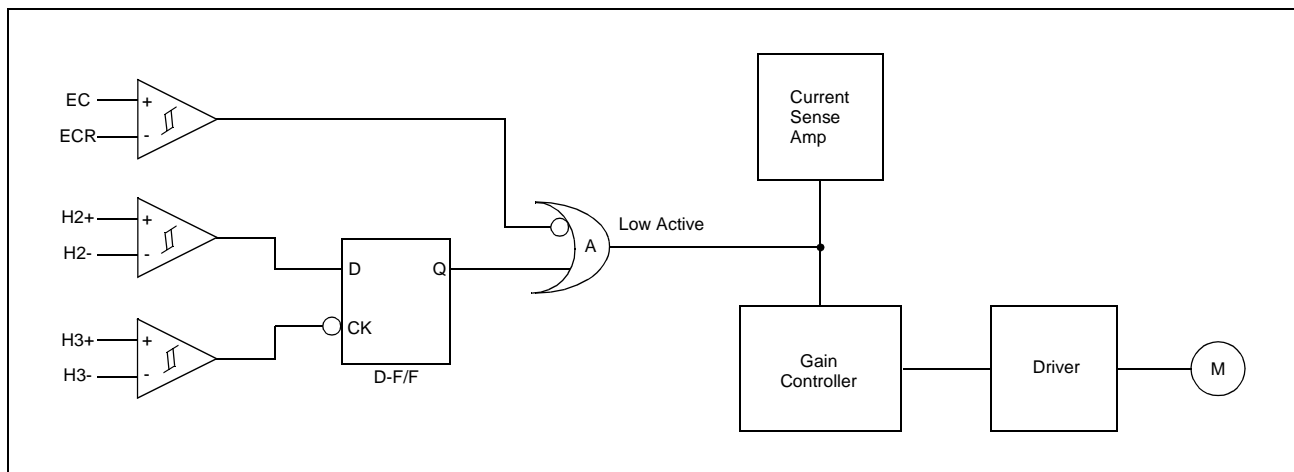

- 1) When the output of the OR Gate, A is LOW, it steers all the output current of the current sense Amp to the Gain Controller zero. The output current of the Driver becomes zero and the motor stops.
- 2) As in the state of the forward rotation, the D-F/F output, Q is HIGH and the motor rotates normally. At this state, if the control input is changed such that $EC > ECR$, then the motor rotates slowly by the reverse commutation in the Driver. When the motor rotates in reverse direction, the D-F/F output becomes Low and the OR Gate output, becomes LOW. This prevents the motor from rotating in reverse direction. The operation principle is shown in the table and the flow chart.

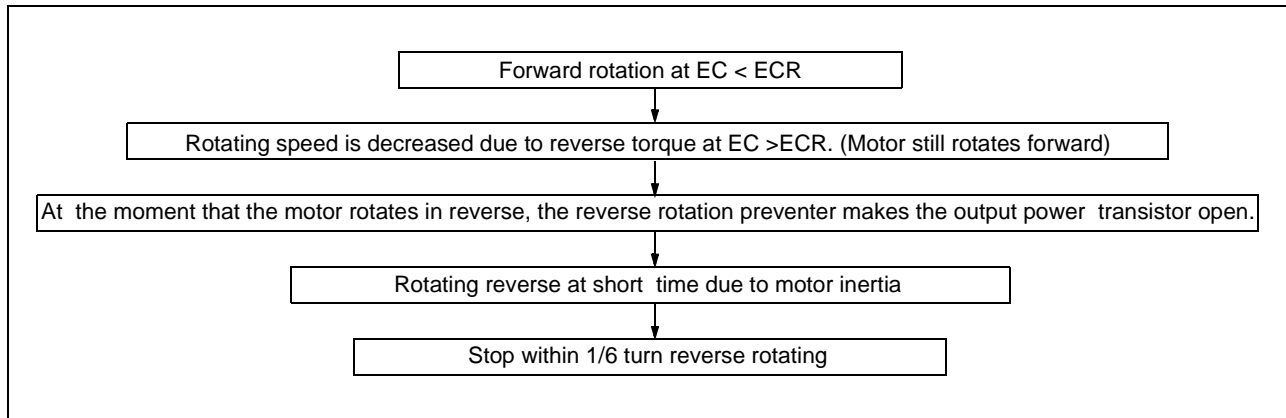

Rotation	H2	H3	D-F/F (Q)	Reverse Rotation Preventer	
				ECR>EC	EC>ECR
Forward	H	H→L	H	Forward	-
Reverse	L	H→L	L	-	Brake and Stop

7. FG OUTPUT

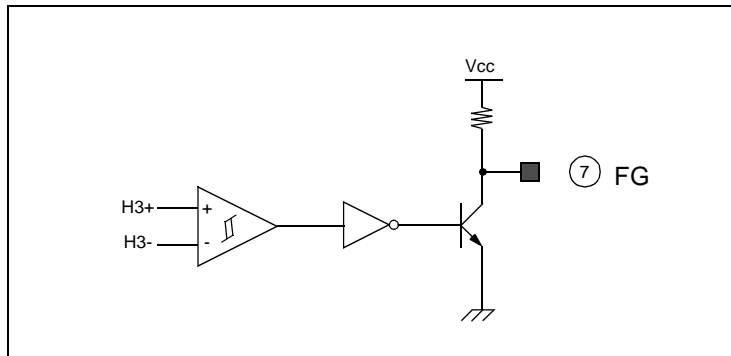

8. HALL SENSOR CONNECTION

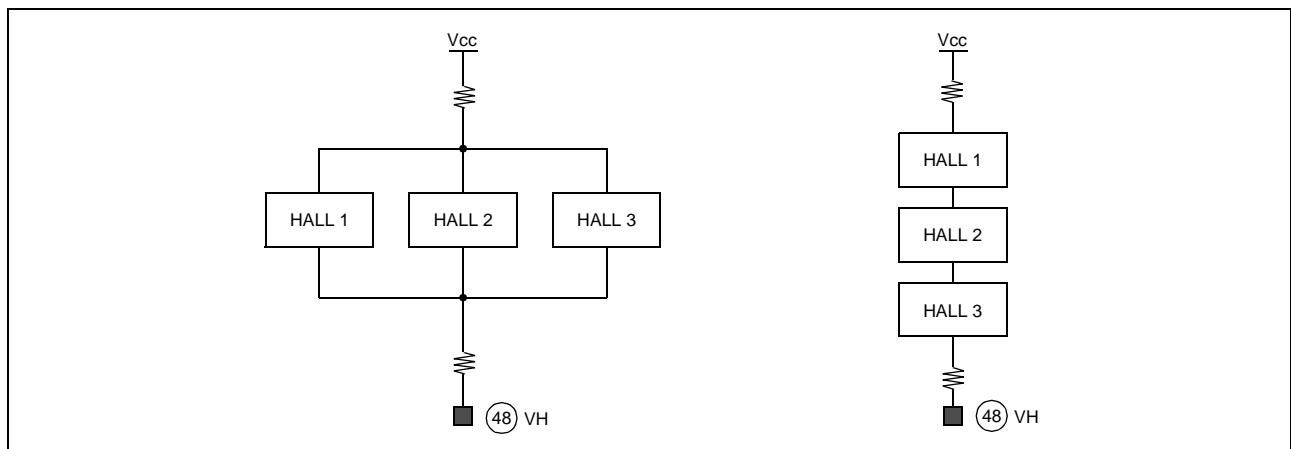

9. CONNECT A BYPASS CAPACITOR, FROM ALL THE SUPPLY VOLTAGE SOURCES TO GROUND.

(Typically 0.1uF, or even higher)

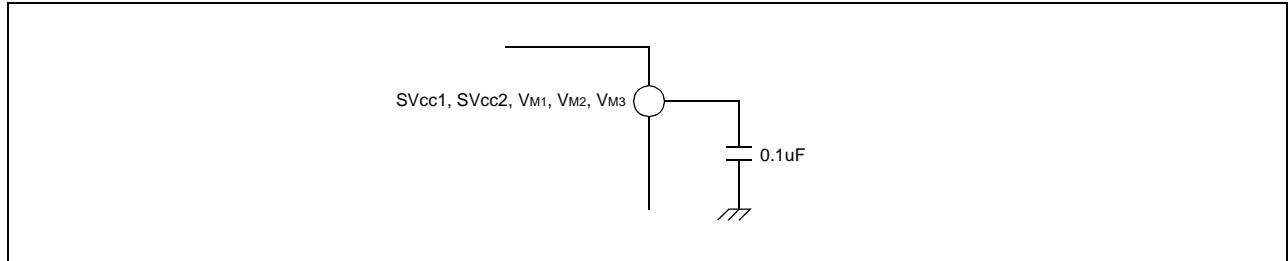

10. THE HEAT RADIATION FIN IS CONNECTED TO THE INTERNAL GND OF THE PACKAGE.

Connect the FIN to the external GND.

11. INPUT-OUTPUT TIMING CHART

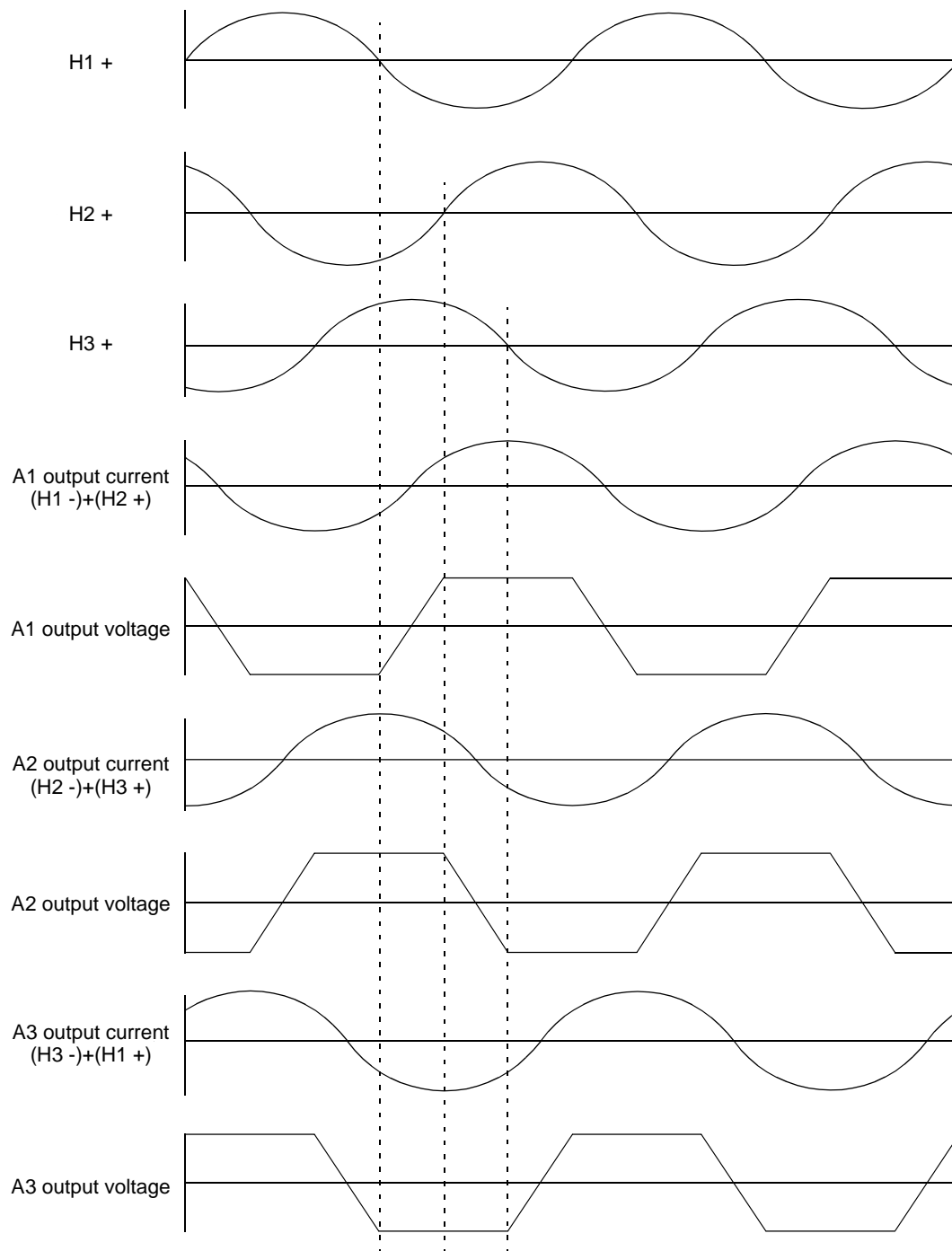

12. BTL DRIVE PART

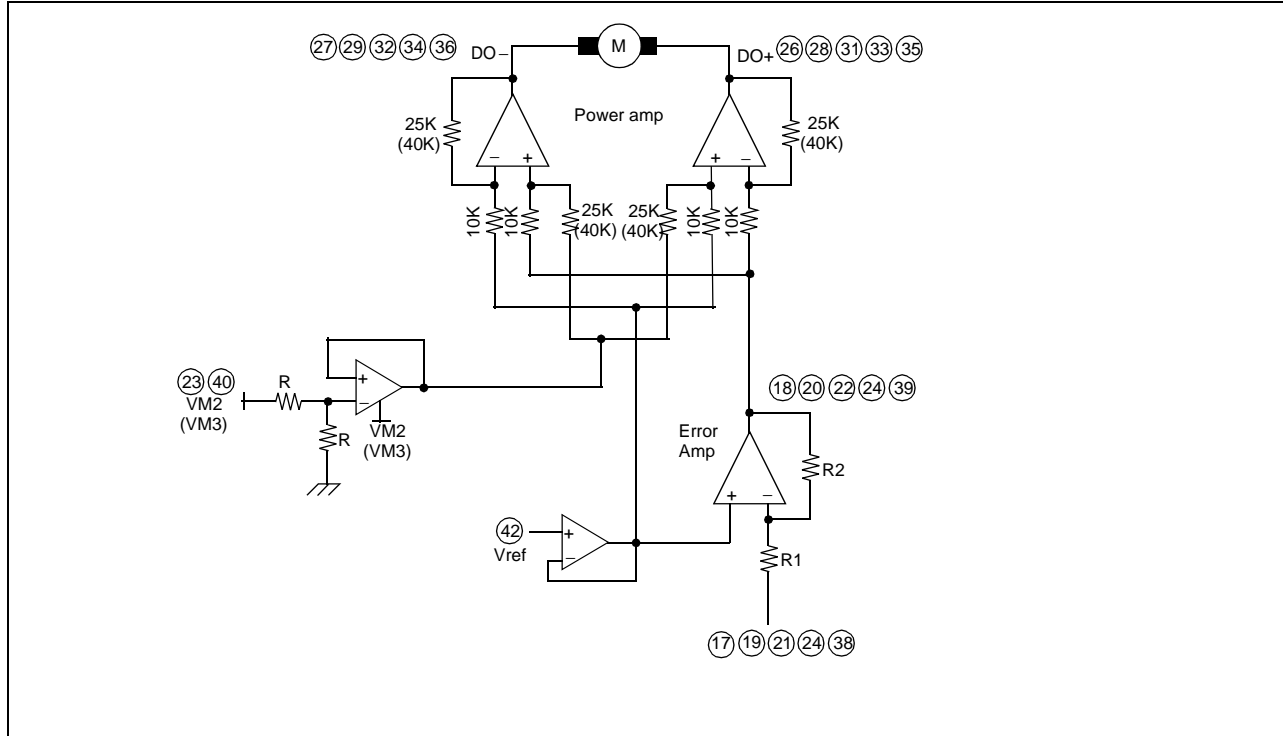

- The reference voltage REF is given externally through pin 42.
- The error amp output signal is amplified by $R2 / R1$ times and then fed to the power amp circuit.
- The power amp circuit produces the differential output voltages and drives the two output power amplifier circuit.
- Since the differential gain of the output amplifiers of CH1/CH2 is equal to $2 \times (25K / 10K)$, the output signal of the error amp is amplified by $(R2 / R1) \times 5$.
- Since the differential gain of the output amplifiers of CH3/CH4/CH5 is equal to $2 \times (40K / 10K)$, the output signal of the error amp is amplified by $(R2 / R1) \times 8$.
- If the total gain is insufficient, the input error amp can be used to increase the gain.
- The CH1/CH2 are generally used as actuator drive circuit so this channels are not affected by TSD circuit.

Typical Application Circuits

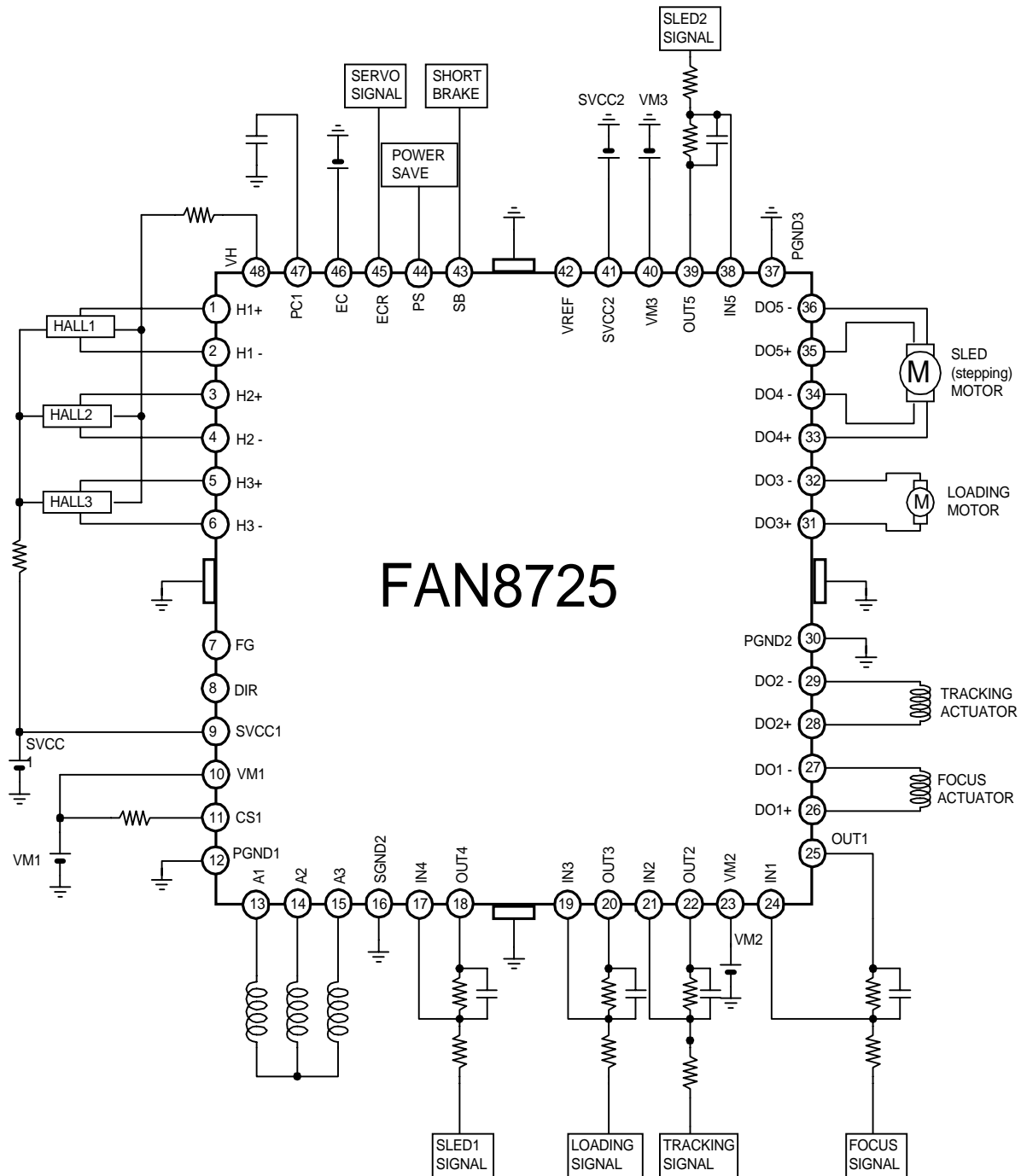

DISCLAIMER

FAIRCHILD SEMICONDUCTOR RESERVES THE RIGHT TO MAKE CHANGES WITHOUT FURTHER NOTICE TO ANY PRODUCTS HEREIN TO IMPROVE RELIABILITY, FUNCTION OR DESIGN. FAIRCHILD DOES NOT ASSUME ANY LIABILITY ARISING OUT OF THE APPLICATION OR USE OF ANY PRODUCT OR CIRCUIT DESCRIBED HEREIN; NEITHER DOES IT CONVEY ANY LICENSE UNDER ITS PATENT RIGHTS, NOR THE RIGHTS OF OTHERS.

LIFE SUPPORT POLICY

FAIRCHILD'S PRODUCTS ARE NOT AUTHORIZED FOR USE AS CRITICAL COMPONENTS IN LIFE SUPPORT DEVICES OR SYSTEMS WITHOUT THE EXPRESS WRITTEN APPROVAL OF THE PRESIDENT OF FAIRCHILD SEMICONDUCTOR INTERNATIONAL. As used herein:

1. Life support devices or systems are devices or systems which, (a) are intended for surgical implant into the body, or (b) support or sustain life, and (c) whose failure to perform when properly used in accordance with instructions for use provided in the labeling, can be reasonably expected to result in a significant injury of the user.
2. A critical component in any component of a life support device or system whose failure to perform can be reasonably expected to cause the failure of the life support device or system, or to affect its safety or effectiveness.