

Resonator

Piezoelectric Resonator (4 to 23.9 MHz)

FAR Family (C4 series N type)

■ DESCRIPTION

Fujitsu resonators C4 series (N type) feature originally developed single crystals with a high electro-mechanical coefficient (LiNbO₃: lithium niobate), the result is very compact packaging.

C4 series (N type) with built-in capacitors for exclusive use in microcomputer clocks, and this series is ultra low profile CHIP type device for surface-mount (SMT).

■ FEATURES

- Ultra low profile H = 1.6 mm
- Direct oscillation in 4 to 23.9 MHz frequency.
- Suitable for the source of microcomputer clock
- Emboss-typed pack for automatic mounting
- Superior shock and vibration resistance, preventing damage during automatic mounting

■ PACKAGE

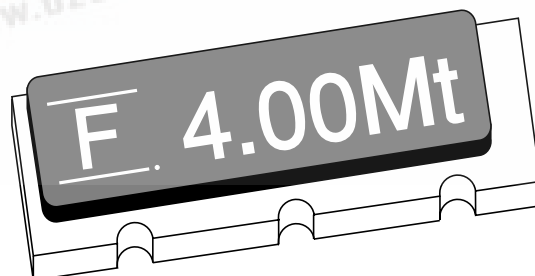

FAR Family (C4 series N type)

STANDARD CHARACTERISTICS

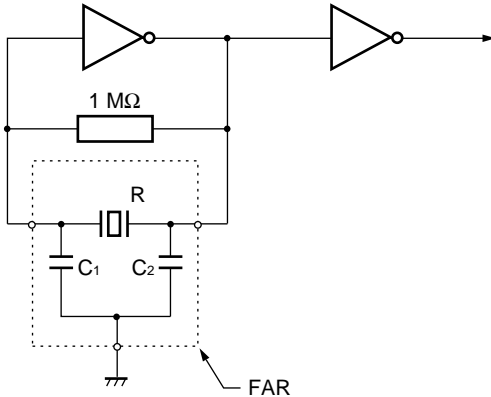
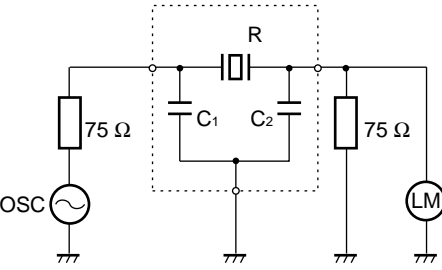
Parameter	Series	C4 series (N type)	Remarks
Material		Lithium Niobate (LiNbO ₃)	
Frequency		4 to 17 MHz 17.1 to 23.9 MHz	
Standard frequency		See "■ Standard Frequency."	
Initial frequency deviation		±0.3% (K) ±0.5% (M) ±1.0% (L)	±1.0% (L) When a frequency of more than 17.1 MHz, only L deviation type can be made.
Temperature characteristic (-20°C to +60°C)		±0.5%	
Capacity of built-in capacitor		20±8 pF (standard)	10±4 pF, 30±8 pF are also available. Capacity is specified by Fujitsu, considering matching data with applied IC (mainly microcomputer).
Aging stability		Within ±0.1%	
Operating temperature		-30°C to +85°C	
Storage temperature		-40°C to +100°C	
Standard measuring circuit		<p>• Resonant frequency</p>  <p>Less than 4 MHz to 10 MHz IC: 1/6MB84069B×2 10 MHz to 20.0 MHz IC: 1/6MC74HC04×2 20.1 MHz to 23.9 MHz IC: 1/6MC74HCU04×2</p> <ul style="list-style-type: none"> • V_{CC}: 5 V DC • R: Resonator • C₁, C₂: Loading capacitors (built-in) <p>• Serial resonant resistance</p>  <p>R: Resonator Measuring instrument: Network analyzer</p>	

FAR Family (C4 series N type)

■ STANDARD FREQUENCY

Standard frequency (kHz)	Package size	Resonant resistance
4,000 4,194 4,915	N	300 Ω max. (Symbol: 0)
6,000 6,144 7,373 8,000 8,388 9,830 10,000 11,059 12,000 12,288 14,746 16,000 16,934 19,661 20,000	N	75 Ω max. (Symbol: 2)

- Notes:**
- Fujitsu can also develop applicable device in addition to standard devices if its oscillation frequency is from 4 to 23.9 MHz.
 - Resonant resistance of the part other than standard, Fujitsu should specify its resonant resistance according to applied frequency. (See “• Frequency and standard resonant resistance.”)
 - Frequency and standard resonant resistance

Frequency	Standard resonant resistance
4.00 to 5.99 MHz	300 Ω max. (Symbol: 0)
6.00 to 23.99 MHz	75 Ω max. (Symbol: 2)

Note: Resonant resistance of custom designed part should be specified considering matching condition with applicable IC by Fujitsu.

■ NOTES ON USE

- Handle carefully
- Solder under the following conditions.
5 seconds max. at 230°C (PCB)
Recommended preheating is 150°C for one minute in order not to apply extreme heat to the resonator.
- Avoid extreme fluctuations in temperature.
- There is no specific direction in resonator mounting.
- Oscillation data should be examined when used in oscillation circuit with micron or other ICs.
- This is for reflow solder, not for flow solder.

FAR Family (C4 series N type)

■ PART NUMBERING SYSTEM

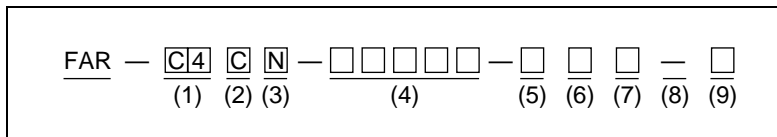

(1) Series

Series	Single crystal	Capacitor
C4	LiNbO ₃	With built-in capacitor

(2) Package Type

Specification	Type
C	CHIP

(3) Package Type

Specification	Size
N	8.0 × 3.2 × 1.6

(4) Frequency

(Example) Unit: kHz (Specify in five digits.)

Frequency	Specification
7.373 MHz	07373

See “■ Standard Frequency”.

(5) Initial Frequency Deviation

Specification	Deviation
K	±0.3%
M	±0.5%
L	±1.0%

(6) Built-in Capacitor

Specification	Capacitance
0	20±8 pF
1	10±4 pF
2	30±8 pF

(7) Resonant Resistance

Specification	Resonant resistance
0	300 Ω max.
2	75 Ω max.

FAR Family (C4 series N type)

(8) User-specific Special Symbols

Specification	Description
Name	No specifications, no taping specification
—	No specifications, with taping specification
A to Z	Serial number for custom design

(9) Resonant Resistance

Specification	Description
R	16 mm wide emboss tape coiled 3,000 times

FAR Family (C4 series N type)

MARKING

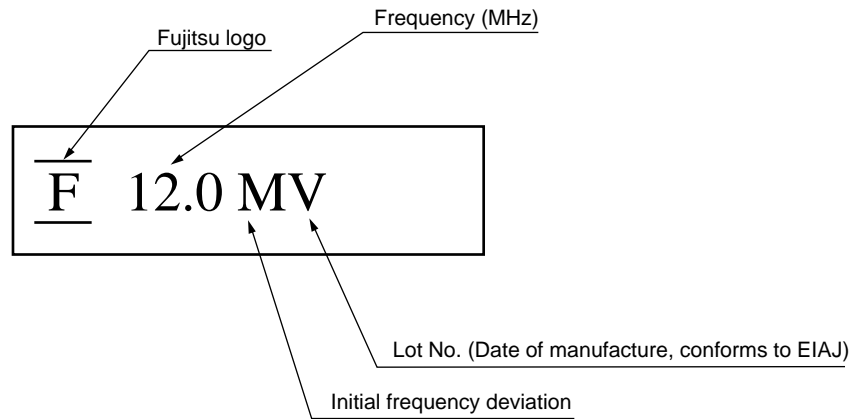

Note: The marking color varies with the capacitance of the built-in capacitor.

Capacitance	Marking color
10 pF	Yellow
20 pF	White
30 pF	Gray

PIN ASSIGNMENT

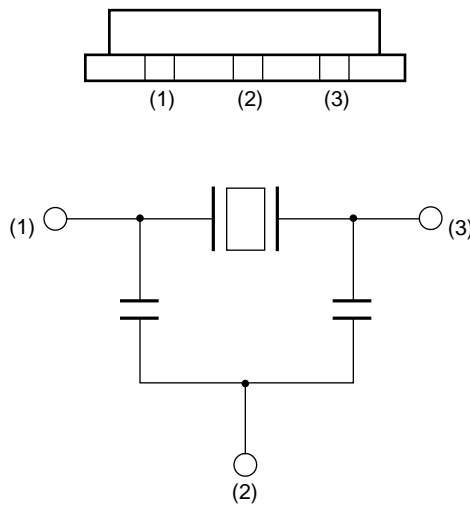

FAR Family (C4 series N type)

■ DIMENSIONS

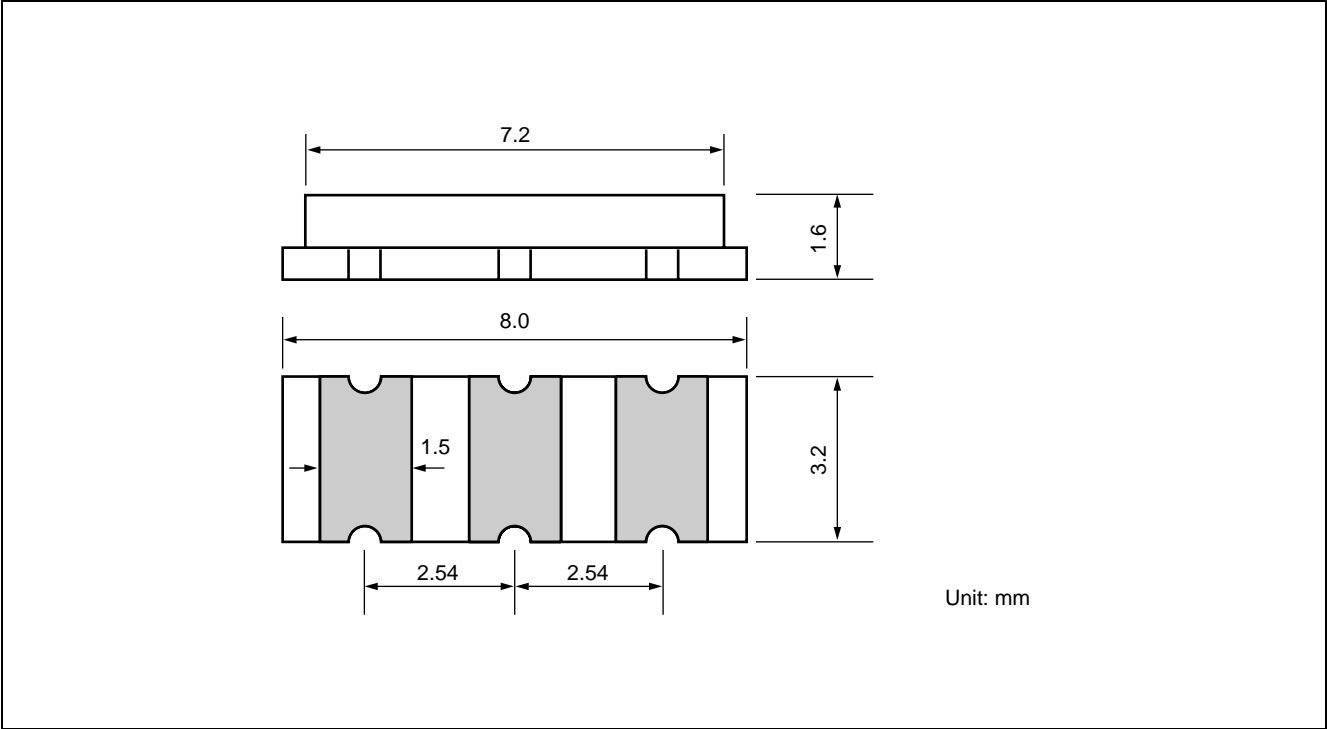

FAR Family (C4 series N type)

■ TAPING FORM AND DIMENSIONS

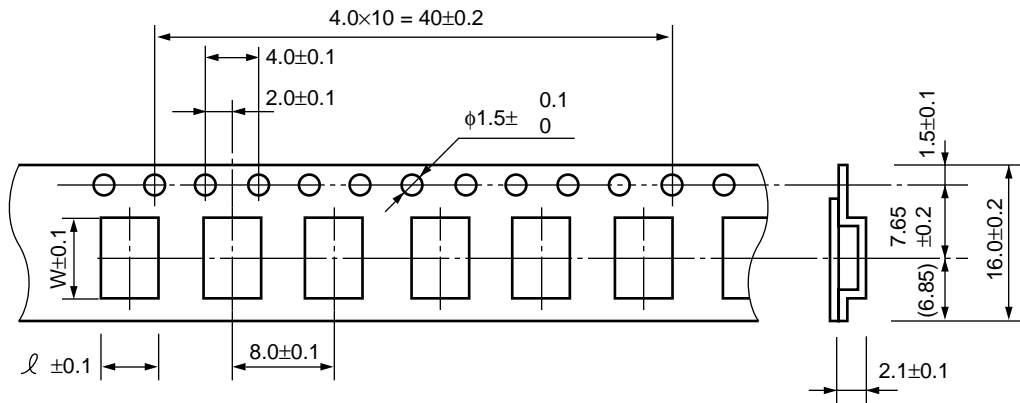

l	W
3.7	8.5

Reel form

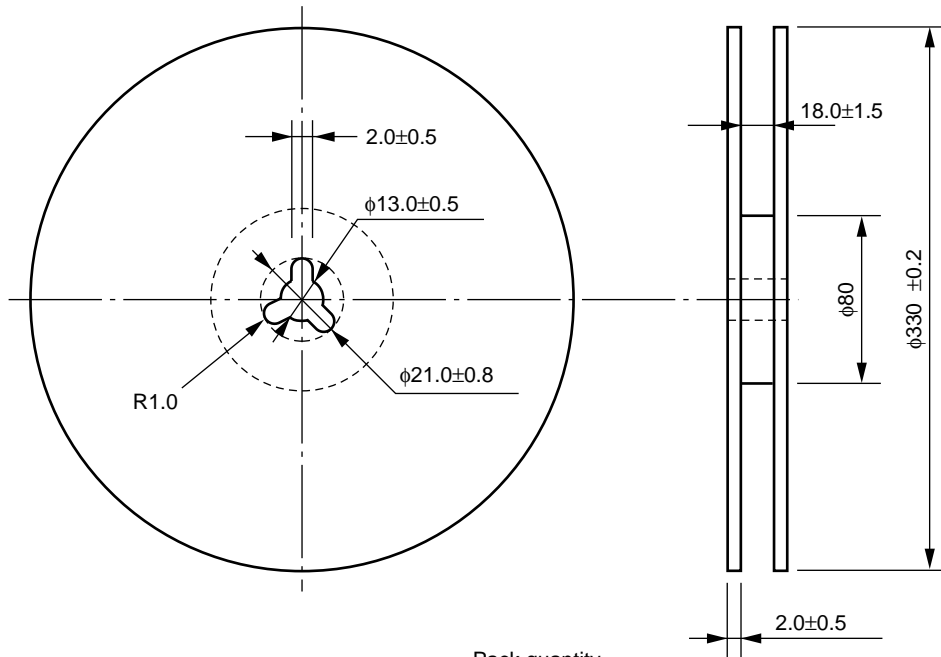

Pack quantity

Quantity
3,000

Unit: mm

FAR Family (C4 series N type)

FUJITSU LIMITED

For further information please contact:

Japan

FUJITSU LIMITED
Corporate Global Business Support Division
Electronic Devices
KAWASAKI PLANT, 4-1-1, Kamikodanaka
Nakahara-ku, Kawasaki-shi
Kanagawa 211-88, Japan
Tel: (044) 754-3753
Fax: (044) 754-3332

North and South America

FUJITSU MICROELECTRONICS, INC.
Semiconductor Division
3545 North First Street
San Jose, CA 95134-1804, U.S.A.
Tel: (408) 922-9000
Fax: (408) 432-9044/9045

Europe

FUJITSU MIKROELEKTRONIK GmbH
Am Siebenstein 6-10
63303 Dreieich-Buchsschlag
Germany
Tel: (06103) 690-0
Fax: (06103) 690-122

Asia Pacific

FUJITSU MICROELECTRONICS ASIA PTE. LIMITED
#05-08, 151 Lorong Chuan
New Tech Park
Singapore 556741
Tel: (65) 281-0770
Fax: (65) 281-0220

All Rights Reserved.

Circuit diagrams utilizing Fujitsu products are included as a means of illustrating typical semiconductor applications. Complete information sufficient for construction purposes is not necessarily given.

The information contained in this document has been carefully checked and is believed to be reliable. However, Fujitsu assumes no responsibility for inaccuracies.

The information contained in this document does not convey any license under the copyrights, patent rights or trademarks claimed and owned by Fujitsu.

Fujitsu reserves the right to change products or specifications without notice.

No part of this publication may be copied or reproduced in any form or by any means, or transferred to any third party without prior written consent of Fujitsu.

The information contained in this document are not intended for use with equipments which require extremely high reliability such as aerospace equipments, undersea repeaters, nuclear control systems or medical equipments for life support.