

Ordering number:EN5099



# FC154

NPN/PNP Epitaxial Planar Silicon Transistor  
**High-Speed Switching,  
 High-Frequency Amp Applications**

## Features

- Composite type with NPN transistor and a PNP transistor contained in the conventional CP package, improving the mounting efficiency greatly.
- The FC154 is formed with two chips, being equivalent to the 2SC4270 and the other the 2SA1699, placed in one package.

## Package Dimensions

unit:mm

2104A

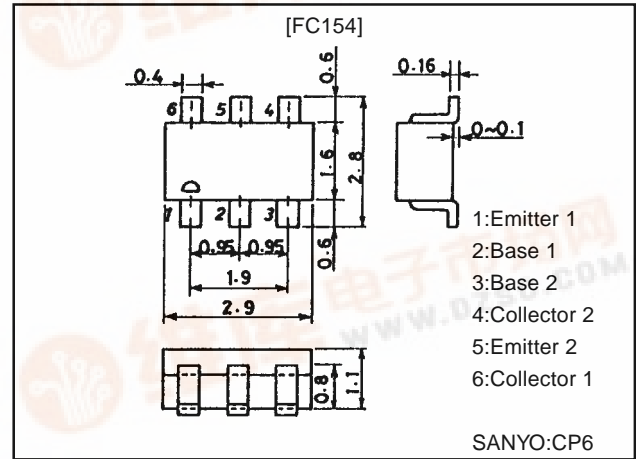

## Electrical Connection

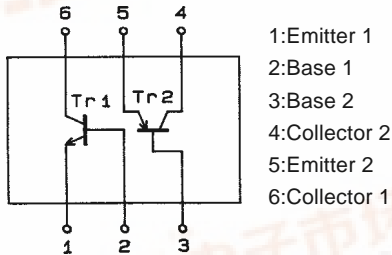

## Specifications

### Absolute Maximum Ratings at Ta = 25°C

Parameter	Symbol	Conditions	Ratings	Unit
[TR1 (NPN Tr)]				
Collector-to-Base Voltage	V <sub>CB0</sub>		25	V
Collector-to-Emitter Voltage	V <sub>CEO</sub>		15	V
Emitter-to-Base Voltage	V <sub>EBO</sub>		3	V
Collector Current	I <sub>C</sub>		50	mA
Collector Dissipation	P <sub>C</sub>		200	mW
[TR2 (PNP Tr)]				
Collector-to-Base Voltage	V <sub>CB0</sub>		-20	V
Collector-to-Emitter Voltage	V <sub>CEO</sub>		-15	V
Emitter-to-Base Voltage	V <sub>EBO</sub>		-3	V
Collector Current	I <sub>C</sub>		-50	mA
Collector Dissipation	P <sub>C</sub>		200	mW
[Common Ratings]				
Total Dissipation	P <sub>T</sub>		300	mW
Junction Temperature	T <sub>j</sub>		150	°C
Storage Temperature	T <sub>stg</sub>		-55 to +150	°C

Marking:154

Continued on next page.



# FC154

Continued from Preceding page.

## Electrical Characteristics at $T_a = 25^\circ\text{C}$

Parameter	Symbol	Conditions	Ratings			Unit
			min	typ	max	
[TR1 (NPN Tr)]						
Collector Cutoff Current	$I_{CBO}$	$V_{CB}=20\text{V}, I_E=0$			0.1	$\mu\text{A}$
Emitter Cutoff Current	$I_{EBO}$	$V_{EB}=2\text{V}, I_C=0$			10	$\mu\text{A}$
DC Current Gain	$h_{FE}$	$V_{CE}=10\text{V}, I_C=5\text{mA}$	60		200	
Gain-Bandwidth Product	$f_T$	$V_{CE}=10\text{V}, I_C=10\text{mA}$	1.5	3.0		GHz
Output Capacitance	$C_{ob}$	$V_{CB}=10\text{V}, f=1\text{MHz}$		0.7	1.0	pF
Power Gain	PG	$V_{CE}=10\text{V}, I_C=10\text{mA}, f=0.9\text{GHz}$		12		dB
Noise Figure	NF	$V_{CE}=10\text{V}, I_C=3\text{mA}, f=0.9\text{GHz}$		3.0		dB
[TR2 (PNPTr)]						
Collector Cutoff Current	$I_{CBO}$	$V_{CB}=-15\text{V}, I_E=0$			-0.1	$\mu\text{A}$
Emitter Cutoff Current	$I_{EBO}$	$V_{EB}=-2\text{V}, I_C=0$			-0.1	$\mu\text{A}$
DC Current Gain	$h_{FE}$	$V_{CE}=-10\text{V}, I_C=-5\text{mA}$	20		100	
Gain-Bandwidth Product	$f_T$	$V_{CE}=-10\text{V}, I_C=-5\text{mA}$	1.5	3.0		GHz
Output Capacitance	$C_{ob}$	$V_{CB}=-10\text{V}, f=1\text{MHz}$		1.0	1.5	pF
Forward Transfer Gain	$ S_{21e} ^2$	$V_{CE}=-10\text{V}, I_C=-5\text{mA}, f=0.9\text{GHz}$	5			dB
Noise Figure	NF	$V_{CE}=-10\text{V}, I_C=-3\text{mA}, f=0.9\text{GHz}$		2.0		dB

## PG, NF Test Circuit

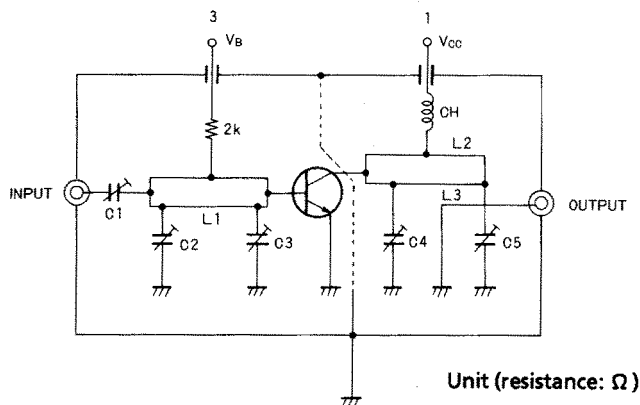

900MHz	
C1	~5pF
C2	~10pF
C3	~10pF
C4	~10pF
C5	~10pF
L1	$W \div 1.5\text{mm}, 1 \div 25\text{mm}$ strip line
L2	$W \div 4\text{mm}, 1 \div 25\text{mm}$ strip line
L3	$0.5\phi, 1 \div 40\text{mm}$
CH	2t + bead core

Unit (resistance:  $\Omega$ )

# FC154

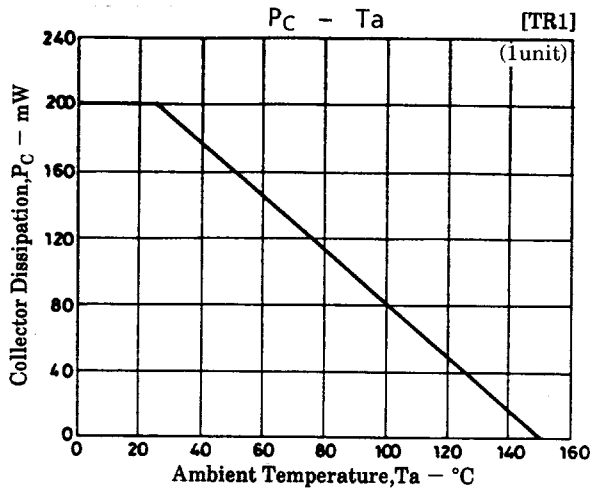
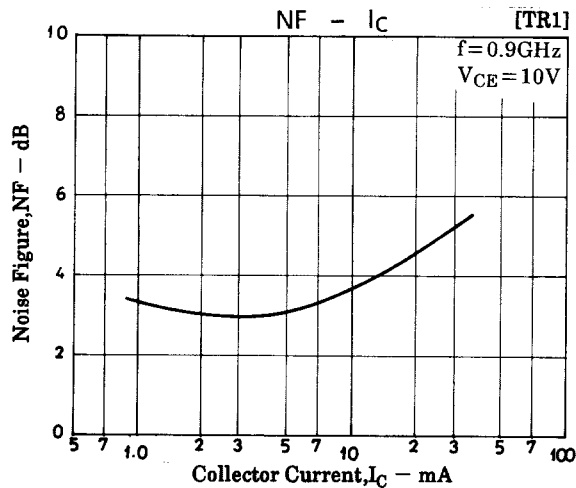
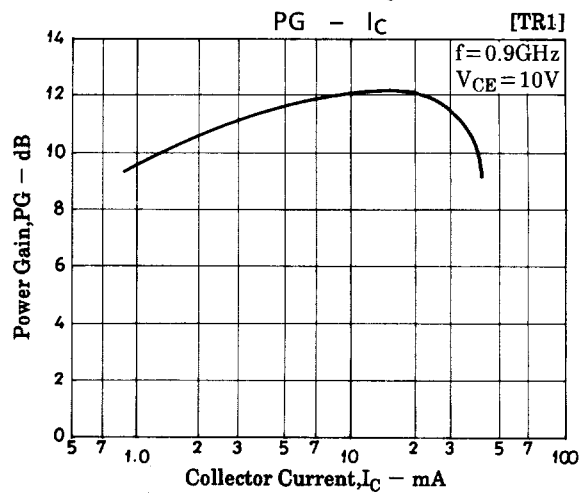
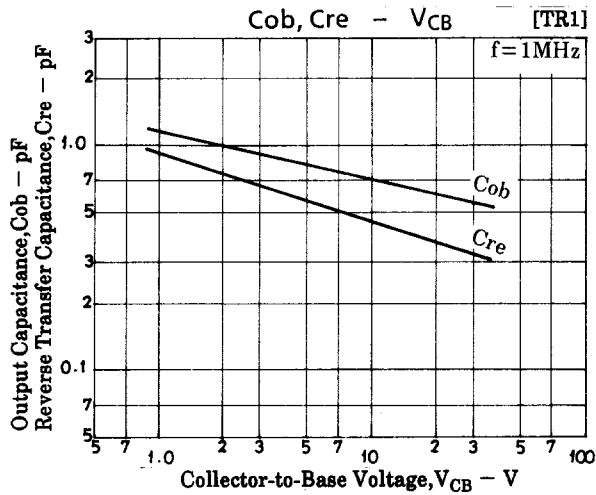
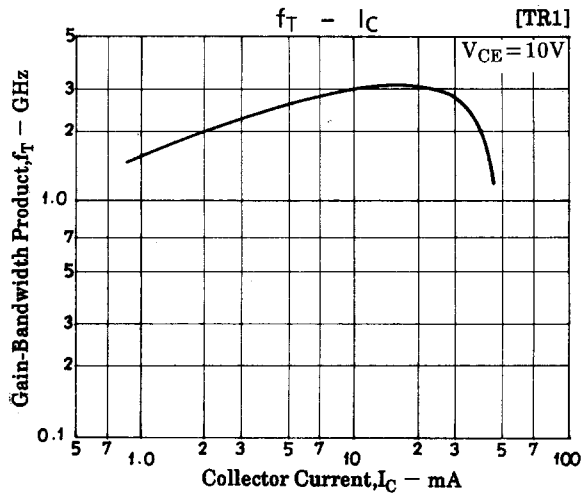
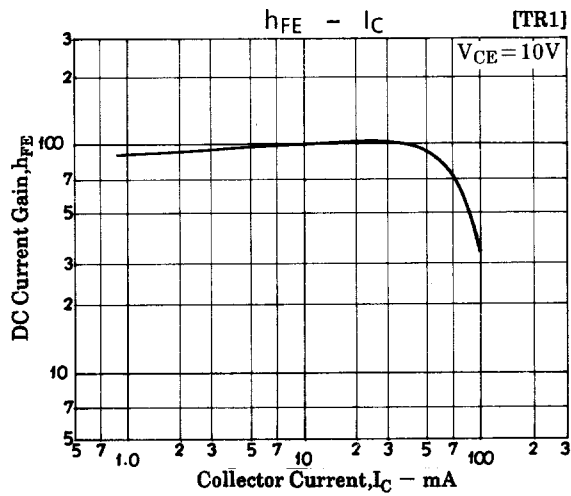

# FC154

## S parameter [TR1]

S11e :  $V_{CE} = 10V$

f = 100MHz, 200 to 1200MHz (200MHz step)

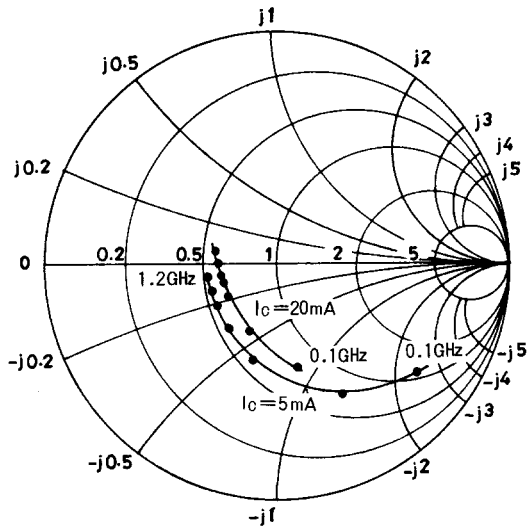

S12e :  $V_{CE} = 10V$

f = 100MHz, 200 to 1200MHz (200MHz step)

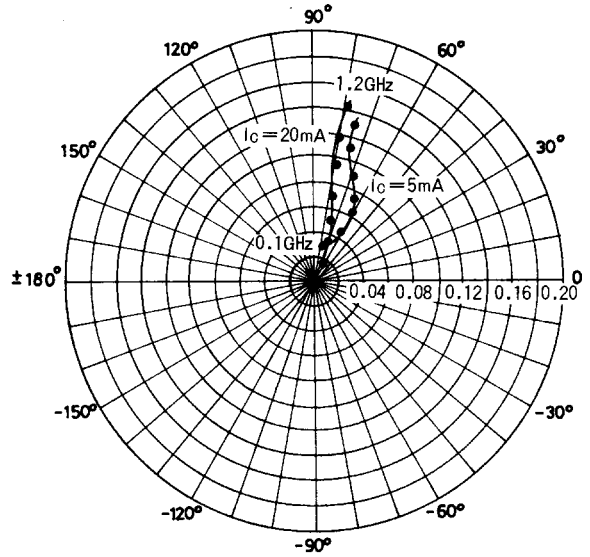

S21e :  $V_{CE} = 10V$

f = 100MHz, 200 to 1200MHz (200MHz step)

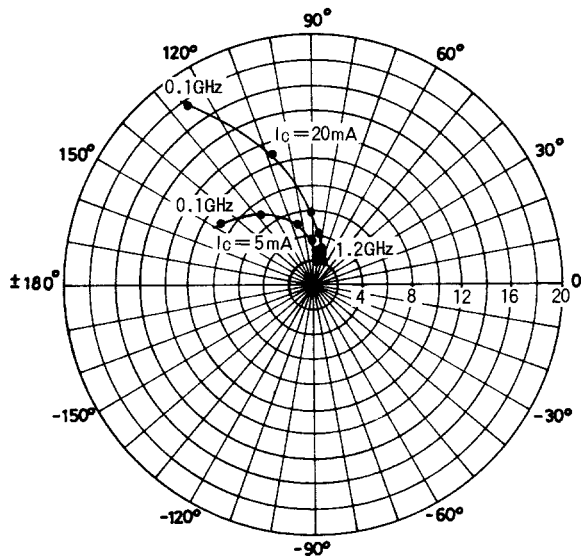

S22e :  $V_{CE} = 10V$

f = 100MHz, 200 to 1200MHz (200MHz step)

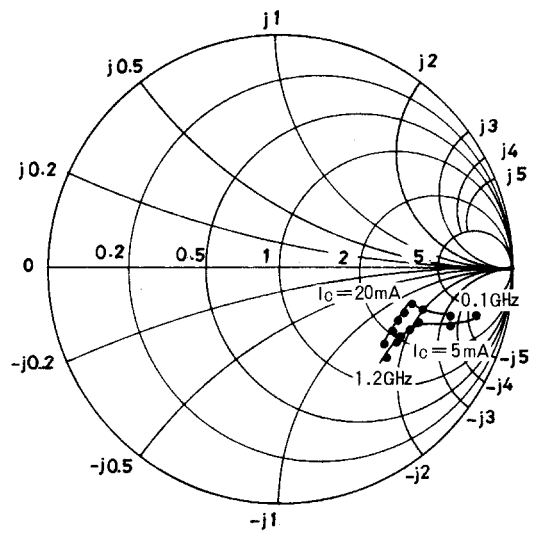

# FC154

## S parameter (Common emitter) [TR1]

$V_{CE} = 10V, I_C = 5mA, Z_0 = 50\Omega$

Freq (MHz)	$ S_{11} $	$\angle S_{11}$	$ S_{21} $	$\angle S_{21}$	$ S_{12} $	$\angle S_{12}$	$ S_{22} $	$\angle S_{22}$
100	0.771	-35.1	8.763	147.2	0.027	69.3	0.890	-14.2
200	0.613	-64.7	7.004	127.6	0.043	59.8	0.780	-19.7
400	0.429	-110.7	4.882	103.1	0.061	58.1	0.660	-22.8
600	0.361	-133.5	3.471	90.5	0.075	63.1	0.625	-25.1
800	0.355	-148.4	2.693	81.6	0.091	68.1	0.612	-28.6
900	0.331	-153.7	2.450	78.9	0.100	70.5	0.609	-29.9
1000	0.328	-158.9	2.236	75.5	0.110	72.5	0.607	-31.6
1200	0.326	-167.9	1.932	69.9	0.130	74.7	0.608	-35.7

$V_{CE} = 10V, I_C = 20mA, Z_0 = 50\Omega$

Freq (MHz)	$ S_{11} $	$\angle S_{11}$	$ S_{21} $	$\angle S_{21}$	$ S_{12} $	$\angle S_{12}$	$ S_{22} $	$\angle S_{22}$
100	0.447	-78.1	17.728	125.0	0.020	66.0	0.752	-18.5
200	0.338	-113.2	10.936	107.5	0.031	66.5	0.639	-18.5
400	0.290	-146.6	5.773	91.4	0.052	72.1	0.580	-18.5
600	0.281	-159.3	3.956	83.0	0.074	75.7	0.571	-21.1
800	0.285	-168.8	2.982	76.2	0.095	77.6	0.566	-25.2
900	0.289	-171.3	2.703	74.0	0.106	78.6	0.563	-26.7
1000	0.291	-174.4	2.454	71.3	0.118	79.4	0.565	-28.6
1200	0.297	-178.1	2.116	66.5	0.140	79.0	0.569	-33.1

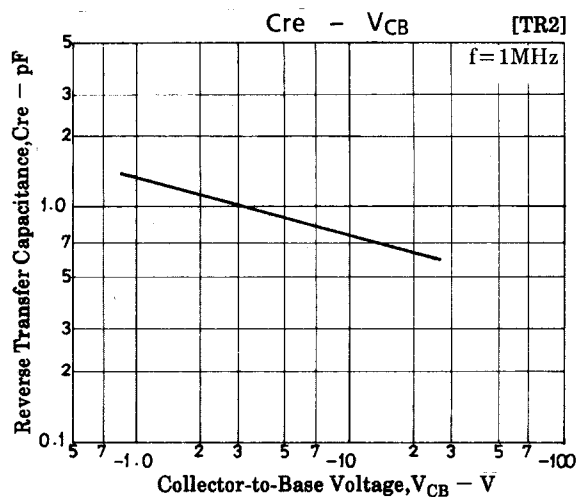
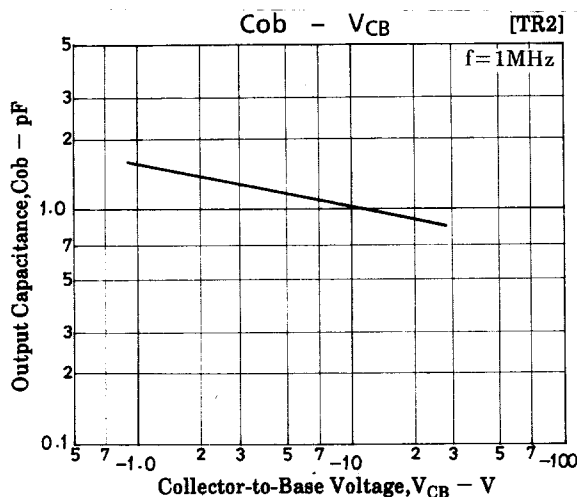
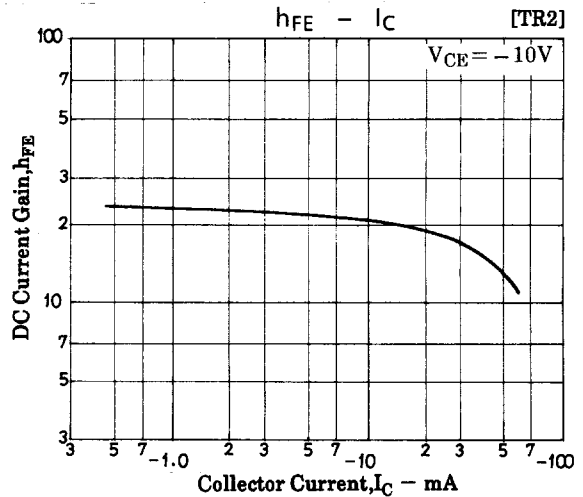
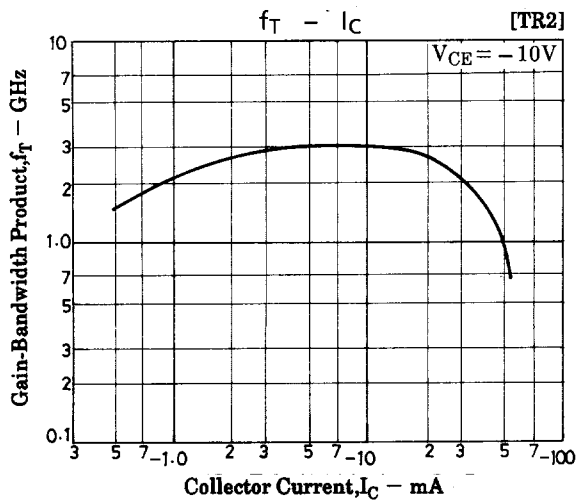

# FC154

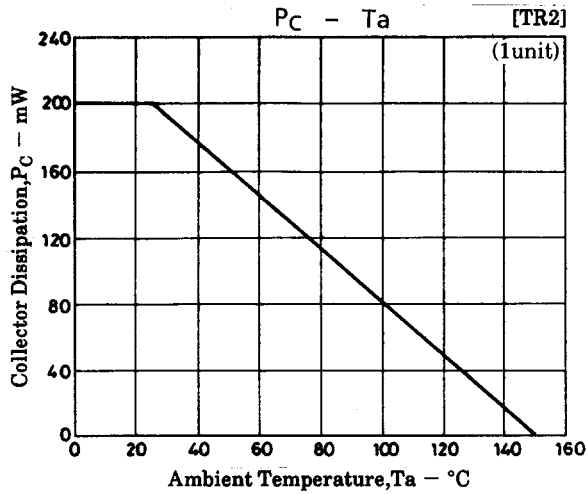
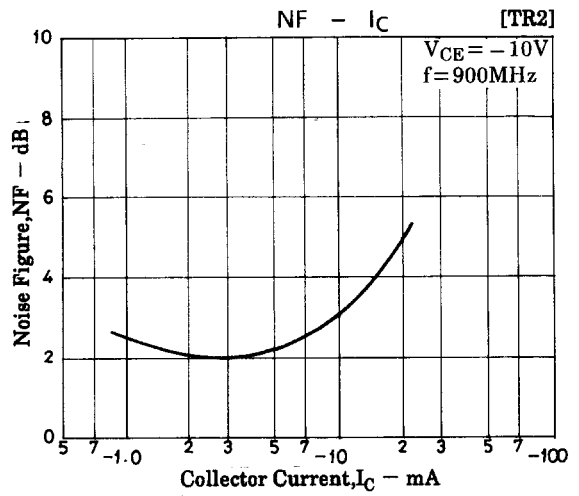
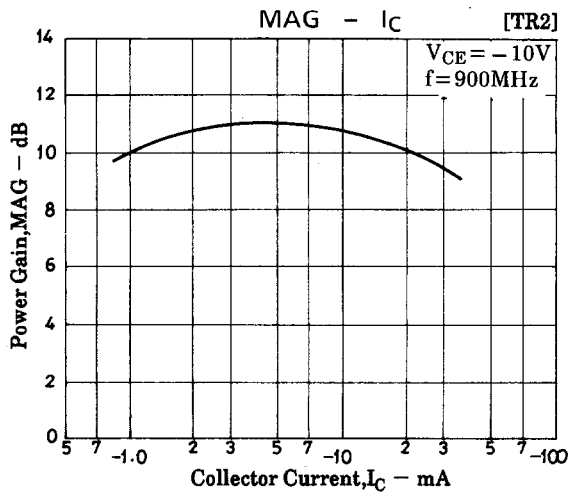

## S parameter [TR2]

S11e:  $V_{CE} = -10V$

$f = 100MHz, 200 \text{ to } 1200MHz (200MHz \text{ step})$

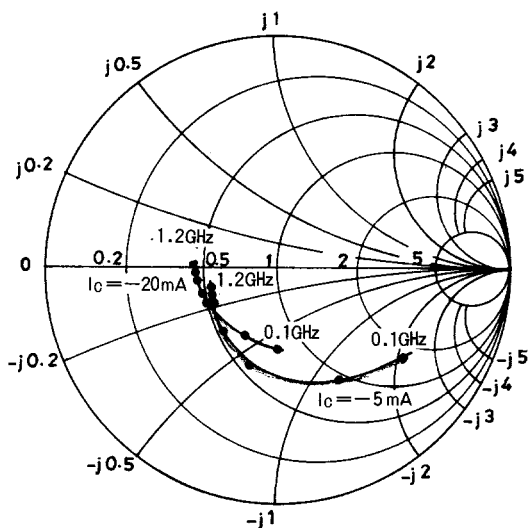

S12e:  $V_{CE} = -10V$

$f = 100MHz, 200 \text{ to } 1200MHz (200MHz \text{ step})$

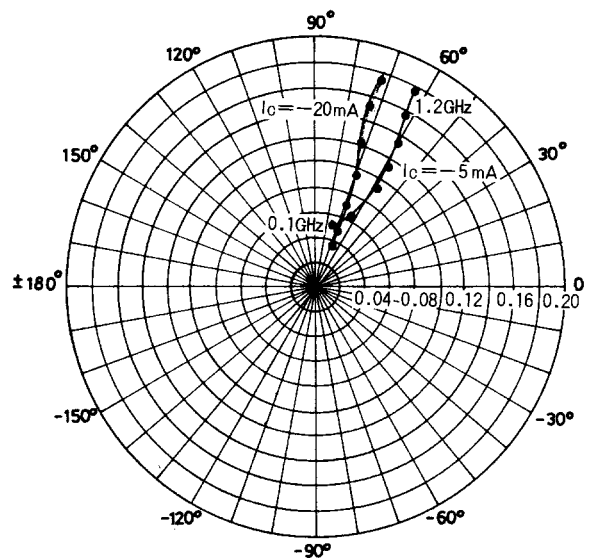

# FC154

**S21e :  $V_{CE} = -10V$   
 $f = 100\text{MHz}, 200 \text{ to } 1200\text{MHz} (200\text{MHz step})$**

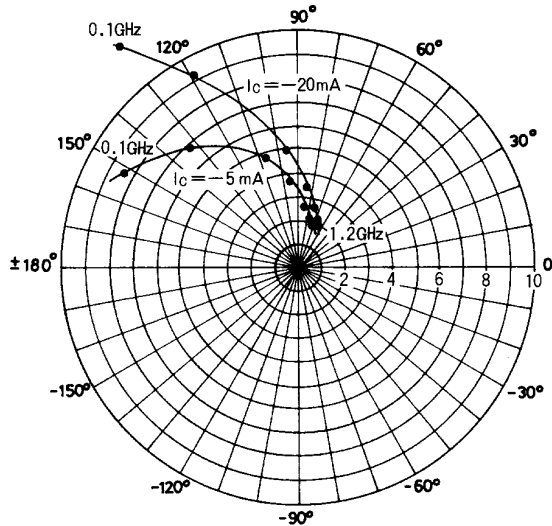

**S22e :  $V_{CE} = -10V$   
 $f = 100\text{MHz}, 200 \text{ to } 1200\text{MHz} (200\text{MHz step})$**

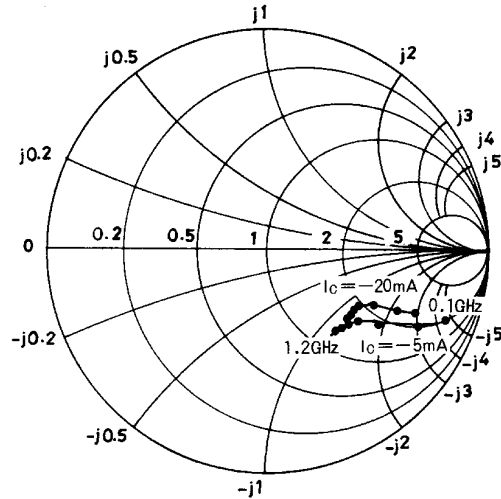

**S parameter (Common emitter) [TR2]**

$V_{CE} = -10V, I_C = -5\text{mA}, Z_0 = 50\Omega$

Freq (MHz)	S <sub>11</sub>	∠S <sub>11</sub>	S <sub>21</sub>	∠S <sub>21</sub>	S <sub>12</sub>	∠S <sub>12</sub>	S <sub>22</sub>	∠S <sub>22</sub>
100	0.707	-33.1	8.215	151.1	0.043	68.6	0.856	-19.8
200	0.589	-60.3	6.763	132.2	0.059	62.0	0.761	-25.4
400	0.435	-104.7	4.810	106.5	0.089	56.4	0.584	-34.2
600	0.373	-128.1	3.503	93.2	0.110	57.3	0.508	-36.6
800	0.349	-144.4	2.728	83.4	0.130	59.5	0.474	-39.0
900	0.346	-150.1	2.492	80.0	0.142	60.9	0.464	-40.3
1000	0.344	-155.4	2.266	76.8	0.154	61.4	0.459	-41.7
1200	0.340	-163.6	1.971	70.6	0.176	62.1	0.452	-45.2

$V_{CE} = -10V, I_C = -20\text{mA}, Z_0 = 50\Omega$

Freq (MHz)	S <sub>11</sub>	∠S <sub>11</sub>	S <sub>21</sub>	∠S <sub>21</sub>	S <sub>12</sub>	∠S <sub>12</sub>	S <sub>22</sub>	∠S <sub>22</sub>
100	0.348	-92.8	12.039	129.4	0.031	67.3	0.727	-22.9
200	0.330	-116.7	9.073	118.2	0.041	66.0	0.634	-24.8
400	0.350	-151.2	4.962	95.1	0.068	67.7	0.510	-26.5
600	0.353	-164.5	3.408	84.4	0.093	69.9	0.481	-28.1
800	0.360	-172.9	2.591	76.4	0.118	71.6	0.470	-31.1
900	0.366	-176.2	2.346	73.3	0.131	72.0	0.467	-32.9
1000	0.371	-178.4	2.142	70.8	0.146	71.8	0.467	-34.8
1200	0.379	-176.2	1.851	65.2	0.171	71.1	0.466	-39.1

■ No products described or contained herein are intended for use in surgical implants, life-support systems, aerospace equipment, nuclear power control systems, vehicles, disaster/crime-prevention equipment and the like, the failure of which may directly or indirectly cause injury, death or property loss.

■ Anyone purchasing any products described or contained herein for an above-mentioned use shall:

- ① Accept full responsibility and indemnify and defend SANYO ELECTRIC CO., LTD., its affiliates, subsidiaries and distributors and all their officers and employees, jointly and severally, against any and all claims and litigation and all damages, cost and expenses associated with such use:
- ② Not impose any responsibility for any fault or negligence which may be cited in any such claim or litigation on SANYO ELECTRIC CO., LTD., its affiliates, subsidiaries and distributors or any of their officers and employees jointly or severally.

■ Information (including circuit diagrams and circuit parameters) herein is for example only; it is not guaranteed for volume production. SANYO believes information herein is accurate and reliable, but no guarantees are made or implied regarding its use or any infringements of intellectual property rights or other rights of third parties.