

## GENERAL INFORMATION AND APPLICATIONS ASSISTANCE

### Introduction

The FC series EMI filters are accessories to the Power-One line of DC to DC Power Converters. They are intended to be used in series with the inputs to the converters, between the source and the converter (with its necessary external input capacitor). A properly sized filter can serve for multiple converters.

There are three sizes of filters, differentiated by their DC current ratings. They are all rated for up to 100 VDC continuous, and for 1500 VDC test voltage from input (or output) to ground. The three DC current ratings are 5.0 A, 10 A and 20 A through current.

Each filter provides both normal mode and common mode attenuation in normal application.

### Document Assistance

The figures and graphs in this document are difficult to read with normal resolution video displays. For improved legibility, print this document.

### MODELS IN THE FC SERIES

There are presently three models in the FC series, all rated for zero to up to 100 VDC input voltage. They differ by current capability. In general, the higher current filters offer higher attenuation than the lower current models.

**Table 1. FC Filter Series Models**

Model	V <sub>in</sub> VDC	I <sub>out</sub> ADC
FC100V5A	0 to 100	5.0
FC100V10A	0 to 100	10.0
FC100V20A	0 to 100	20.0

### FC MODEL NUMBERING CONVENTION

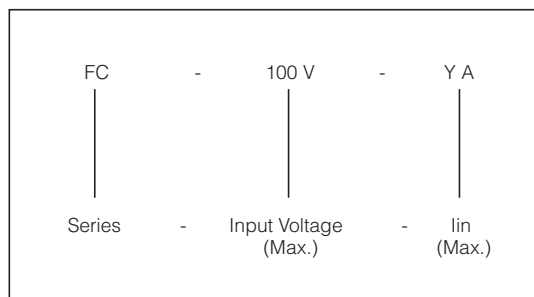

Custom models with alternate input voltages, or input current range, or different physical constructions are available. Consult the Power-One factory.

## DESIGN CONSIDERATIONS

Switching Power Converter modules, because they are essentially constant efficiency over the input voltage range, must be connected to a low AC impedance source of DC voltage.

A constant efficiency power module exhibits an input voltage versus current characteristic which electrically resembles a negative resistor in the normal operating range of the module. Constant efficiency means that if the output power is held constant, the input power will remain constant across the operating input voltage range. If the source voltage rises, the current drawn from the source will fall, to maintain a constant product of voltage and current, hence, constant input power. This characteristic is that of a negative resistor. When a negative resistance is fed from a positive source impedance which has a greater magnitude than that of the negative resistance, either the system crashes or it becomes unstable. A good general rule is that the magnitude of the source impedance must be lower than the magnitude of the input impedance of the module, at all frequencies up to the switching frequency of the module. (The classic reference is Middlebrook and Cuk, "Input Filter Considerations in Design and Application of Switching Regulators," *Advances in Switched-Mode Power Conversion*, pp 91-107, TeslaCo, 1981.) This rule is especially important, and harder to follow, with higher power modules because the magnitude of the negative input impedance is lower.

The normal solution is to place a low impedance capacitor directly across the input terminals of the module. 100 to 220  $\mu\text{F}$  is usually recommended for output power levels up to 300 Watts. This capacitor insures that the magnitude of the source impedance is lower than that of the module input impedance. Note: this assumes that the DC source resistance is sufficiently low; nothing can correct this problem. Too high a DC source resistance means that the necessary energy required by the input of the module is not available, and this system will not work.

Use of the capacitor complicates the system design. There must be some consideration of the surge current required to charge the capacitor when power is first applied. A surge limiting mechanism may be required. The capacitor may form a resonant circuit with the inductance of an EMI filter. If this happens, the resonance will require damping. The capacitor must be rated to handle all of the reflected ripple current of the module. Adding damping in the form of a resistor in series with the capacitor may reduce the ripple current in the capacitor. A small value, high ripple current capacitor may then be required in parallel with the damped electrolytic in order to meet the EMI requirements. The system designer must evaluate all of these requirements and make the correct choices for the application.

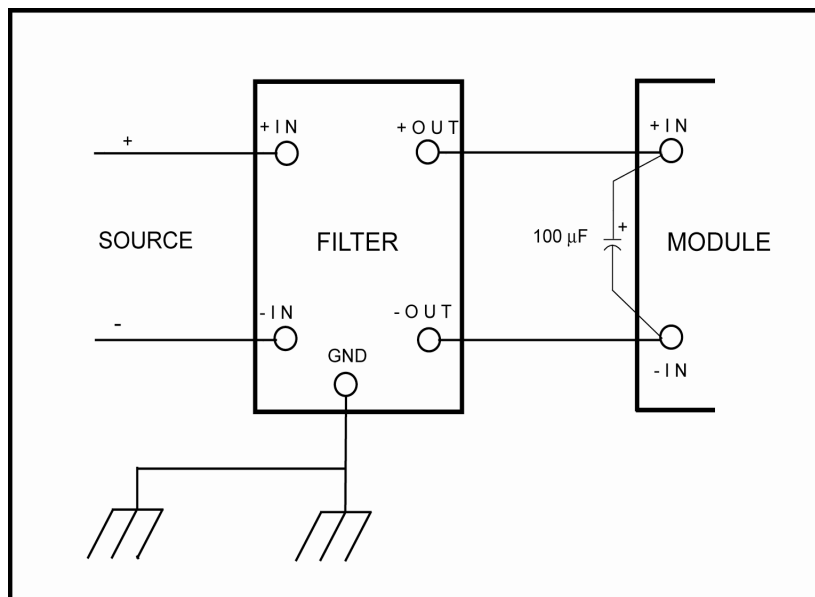

Figure 1. Application of Input Filters



### **DC Current Ratings:**

FC filters are rated for 5.0, 10.0, and 20.0 amperes DC at up to +60° C. ambient temperature with 400 LFM of forced air across the module surface, or with the case temperature otherwise held to a maximum of +100° C. With no forced air and no additional cooling, the same modules are rated for 3.5, 6.5, and 13 amperes maximum.

### **SAFETY CONSIDERATIONS**

#### **Isolation:**

The FC series EMI filters have 1500 Volt DC isolation from input or output to ground, but no isolation from input to output. The output voltage is the input voltage.

#### **Fusing:**

These filters have no external fuse. An external fuse must always be employed. In general, a 250 volt rated fuse must be used to meet international safety requirements. The fuse value should be selected to be greater than the maximum input current of the filter, which occurs at the minimum input voltage of the modules being powered through the filter. Both input traces and the chassis ground trace (if used) must be capable of conducting a current of 1.5 times the value of the fuse without opening. If one of the input lines is connected to chassis ground, then the fuse must be in the other input line.

#### **Case Grounding:**

The FC series filters have a non-metallic case. It cannot be grounded. Each filter has a ground pin which must be connected, with as low an impedance as possible, to chassis ground in order for the filter to function properly.

### **INPUT SHUTDOWN PIN**

Many DC to DC Converter modules have an input “shutdown”, or “control” or “ON/OFF” pin. In most cases, the reference or return for this pin is the negative input pin of the module. When using such a system with an EMI filter module, the shutdown return must be made directly to the pin of the module, which is the output of the filter, and not at the input of the filter. This requires either an optical coupler or a relay, or other fully isolated device to control the module. There must not be any path for DC current to bypass the module, or its filtering characteristics will be severely compromised.

In order to operate without the internal common mode inductors magnetically saturating, the positive leg and negative leg currents in the filter must exactly equal. Even a small imbalance, as small as 10 ma, can create saturation of the inductors. When this happens, they no longer function as filter elements.

**Table 2. FC100V5A Specifications**

FC100V5A Electrical Specifications EMI Filter						
PARAMETER	MIN	TYP	MAX	UNITS	CONDITIONS	NOTES
<b>INPUT</b>						
Input Voltage Range	0	48	100	V		All specifications typical at +25° C, nominal line, and full load unless otherwise noted. Specifications subject to change without notice.
Maximum average current			5	A	Ta = 60° C 400 lfm air	
			3.5	A	Ta = 60° C natural convection	
Frequency	0		60	Hz		
<i>Typical Characteristics</i>						
Resistance per leg		27		mΩ		
Common-mode insertion loss		30		dB		At 500 kHz, 50 Ohm circuit
Differential-mode insertion loss		28		dB		At 500 kHz, 50 Ohm circuit
Isolation voltage; Allows power module to meet FCC CISPR and EN55022 Class B conducted limits.		1500		Vdc		
MTBF				Mhr	Consult Factory	
<b>ENVIRONMENTAL</b>						
Case Operating Temperature	-40		+100	°C		
Storage Temperature Range	-40		+100	°C		
Operating & Storage Humidity			95	%	Non-Condensing	
Temperature Coefficient			0.03	%/°C		
Vibration			5	G	Three orthogonal axes; 5 minute test on each; 10 to 55 Hz	
<b>PHYSICAL</b>						
Case Dimensions	1.00 L	1.0 W	0.40 H	in		

**Table 3. FC100V10A Specifications**

FC100V10A Electrical Specifications EMI Filter						
PARAMETER	MIN	TYP	MAX	UNITS	CONDITIONS	NOTES
<b>INPUT</b>						
Input Voltage Range	0	48	100	V		All specifications typical at +25° C, nominal line, and full load unless otherwise noted. Specifications subject to change without notice.
Maximum average current			10	A	Ta = 60° C 400 lfm air	
			6.5	A	Ta = 60° C natural convection	
Frequency	0		60	Hz		
<i>Typical Characteristics</i>						
Resistance per leg		17		mΩ		
Common-mode insertion loss		28		dB		At 500 kHz, 50 Ohm circuit
Differential-mode insertion loss		31		dB		At 500 kHz, 50 Ohm circuit
Isolation voltage; Allows power module to meet FCC CISPR and EN55022 Class B conducted limits.		1500		Vdc		
MTBF				Mhr	Consult Factory	
<b>ENVIRONMENTAL</b>						
Case Operating Temperature	-40		+100	°C		
Storage Temperature Range	-40		+100	°C		
Operating & Storage Humidity			95	%	Non-Condensing	
Temperature Coefficient			0.03	%/°C		
Vibration			5	G	Three orthogonal axes; 5 minute test on each; 10 to 55 Hz	
<b>PHYSICAL</b>						
Case Dimensions	2.00 L	1.0 W	0.44 H	in		

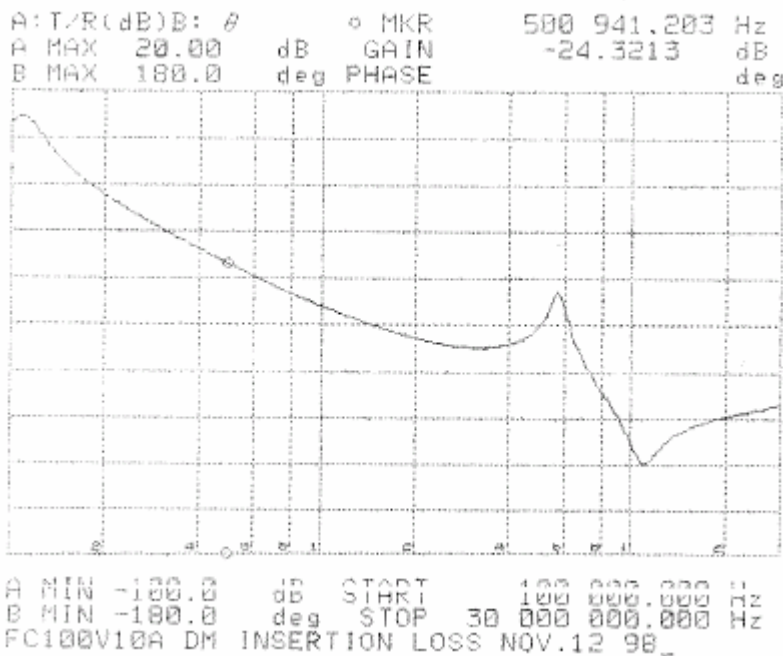

**Module:** FC100V10A, ten ampere EMI filter.  
**Instrument:** Hewlett-Packard model 4194A  
**Start Freq:** 100 kHz.  
**Stop Frequency:** 30 MHz.  
**Scale:** 12 dB per division.  
**System:** 50 Ω in and 50 Ω out.

**Figure 8. Differential Mode Attenuation Plot**

**FC100V20A MODULE DETAILS**

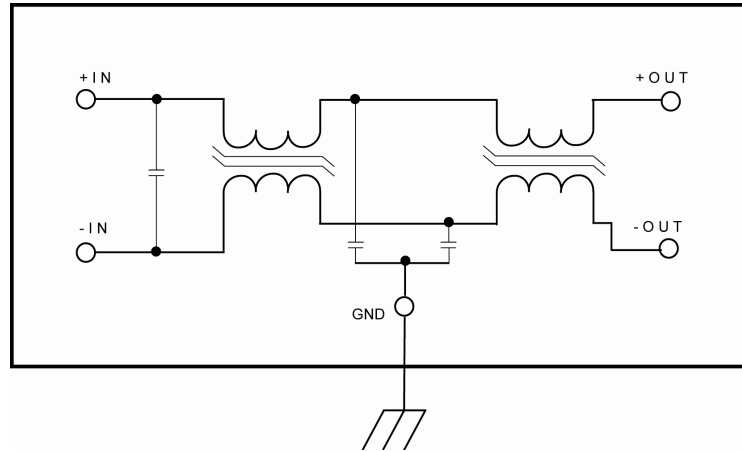

**Figure 11. Filter Block Schematic**

**Table 4. FC100V20A Specifications**

FC100V20A Electrical Specifications EMI Filter						
PARAMETER	MIN	TYP	MAX	UNITS	CONDITIONS	NOTES
<b>INPUT</b>						
Input Voltage Range	0	48	100	V		All specifications typical at +25° C, nominal line, and full load unless otherwise noted. Specifications subject to change without notice.
Maximum average current			20	A	Ta = 60° C 400 lfm air	
			13	A	Ta = 60° C natural convection	
Frequency	0		60	Hz		
<i>Typical Characteristics</i>						
Resistance per leg		10		mΩ		
Common-mode insertion loss		32		dB		At 500 kHz, 50 Ohm circuit
Differential-mode insertion loss		26		dB		At 500 kHz, 50 Ohm circuit
Isolation voltage; Allows power module to meet FCC CISPR and EN55022 Class B conducted limits.		1500		Vdc		
MTBF				Mhr	Consult Factory	
<b>ENVIRONMENTAL</b>						
Case Operating Temperature	-40		+100	°C		
Storage Temperature Range	-40		+100	°C		
Operating & Storage Humidity			95	%	Non-Condensing	
Temperature Coefficient			0.03	%/°C		
Vibration			5	G	Three orthogonal axes; 5 minute test on each; 10 to 55 Hz	
<b>PHYSICAL</b>						
Case Dimensions	2.00 L	1.6 W	0.46 H	in		