

International IOR Rectifier

I27139- 01/03

FC40SA50FK

HEXFET® Power MOSFET

Applications

- Switch Mode Power Supply (SMPS)
- Uninterruptible Power Supply
- High Speed Power Switching
- Hard Switched and High Frequency Circuits

V _{DSS}	R _{DS(on)} typ.	I _D
500V	0.084 Ω	40A

Benefits

- Low Gate Charge Q_g results in Simple Drive Requirement
- Improved Gate, Avalanche and Dynamic dv/dt Ruggedness
- Fully Characterized Capacitance and Avalanche Voltage and Current
- Low R_{DS(on)}
- Fully Insulated Package

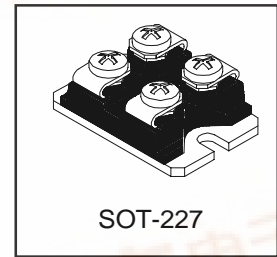

Absolute Maximum Ratings

	Parameter	Max.	Units
I _D @ T _C = 25°C	Continuous Drain Current, V _{GS} @ 10V	40	A
I _D @ T _C = 100°C	Continuous Drain Current, V _{GS} @ 10V	26	
I _{DM}	Pulsed Drain Current ①	160	
P _D @ T _C = 25°C	Power Dissipation	430	W
	Linear Derating Factor	3.45	W/°C
V _{GS}	Gate-to-Source Voltage	± 30	V
dv/dt	Peak Diode Recovery dv/dt ②	9.0	V/ns
T _J	Operating Junction and	-55 to + 150	°C
T _{STG}	Storage Temperature Range		

Avalanche Characteristics

Symbol	Parameter	Typ.	Max.	Units
E _{AS}	Single Pulse Avalanche Energy ②	–	1240	mJ
I _{AR}	Avalanche Current ①	–	40	A
E _{AR}	Repetitive Avalanche Energy ①	–	43	mJ

Thermal Resistance

Symbol	Parameter	Typ.	Max.	Units
R _{θJC}	Junction-to-Case	–	0.29	°C/W
R _{θCS}	Case-to-Sink, Flat, Greased Surface	0.05	–	

Static @ T_J = 25°C (unless otherwise specified)

Symbol	Parameter	Min.	Typ.	Max.	Units	Conditions
V _{(BR)DSS}	Drain-to-Source Breakdown Voltage	500	–	–	V	V _{GS} = 0V, I _D = 250μA
ΔV _{(BR)DSS/ΔT_J}	Breakdown Voltage Temp. Coefficient	–	0.60	–	V/°C	Reference to 25°C, I _D = 1mA④
R _{DS(on)}	Static Drain-to-Source On-Resistance	–	0.084	0.10	Ω	V _{GS} = 10V, I _D = 24A ④
V _{GS(th)}	Gate Threshold Voltage	3.0	–	5.0	V	V _{DS} = V _{GS} , I _D = 250μA
I _{DSS}	Drain-to-Source Leakage Current	–	–	50	μA	V _{DS} = 500V, V _{GS} = 0V
		–	–	250		V _{DS} = 400V, V _{GS} = 0V, T _J = 125°C
I _{GSS}	Gate-to-Source Forward Leakage	–	–	250	nA	V _{GS} = 30V
	Gate-to-Source Reverse Leakage	–	–	-250		V _{GS} = -30V

Dynamic @ T_J = 25°C (unless otherwise specified)

Symbol	Parameter	Min.	Typ.	Max.	Units	Conditions
g _{fs}	Forward Transconductance	23	–	–	S	V _{DS} = 50V, I _D = 28A
Q _g	Total Gate Charge	–	–	270	nC	I _D = 40A
Q _{gs}	Gate-to-Source Charge	–	–	84		V _{DS} = 400V
Q _{gd}	Gate-to-Drain ("Miller") Charge	–	–	130		V _{GS} = 10V, See Fig. 6 and 13 ④
t _{d(on)}	Turn-On Delay Time	–	25	–		V _{DD} = 250V
t _r	Rise Time	–	140	–	ns	I _D = 40A
t _{d(off)}	Turn-Off Delay Time	–	55	–		R _G = 1.0Ω
t _f	Fall Time	–	74	–		V _{GS} = 10V, See Fig. 10 ④
C _{iss}	Input Capacitance	–	8310	–	pF	V _{GS} = 0V
C _{oss}	Output Capacitance	–	960	–		V _{DS} = 25V
C _{rss}	Reverse Transfer Capacitance	–	120	–		f = 1.0MHz, See Fig. 5
C _{oss}	Output Capacitance	–	10170	–		V _{GS} = 0V, V _{DS} = 1.0V, f = 1.0MHz
C _{oss}	Output Capacitance	–	240	–		V _{GS} = 0V, V _{DS} = 480V, f = 1.0MHz
C _{oss eff.}	Effective Output Capacitance	–	440	–		V _{GS} = 0V, V _{DS} = 0V to 480V ⑤

Diode Characteristics

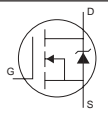
Symbol	Parameter	Min.	Typ.	Max.	Units	Conditions
I _S	Continuous Source Current (Body Diode)	–	–	40	A	MOSFET symbol showing the integral reverse p-n junction diode. 
I _{SM}	Pulsed Source Current (Body Diode) ①	–	–	160		
V _{SD}	Diode Forward Voltage	–	–	1	V	T _J = 25°C, I _S = 40A, V _{GS} = 0V ④
t _{rr}	Reverse Recovery Time	–	620	940	ns	T _J = 25°C, I _F = 47A
Q _{rr}	Reverse Recovery Charge	–	14	21	μC	di/dt = 100A/μs ④
I _{RRM}	Reverse Recovery Current	–	38	–	A	T _J = 25°C
t _{on}	Forward Turn-On Time	Intrinsic turn-on time is negligible (turn-on is dominated by L _S +L _D)				

Notes:

- ① Repetitive rating; pulse width limited by max. junction temperature. (See Fig. 11)
- ② Starting T_J = 25°C, L = 1.55mH, R_G = 25Ω, I_{AS} = 40A, dv/dt = 5.5V/ns (See Figure 12a)
- ③ I_{SD} ≤ 40A, di/dt ≤ 150A/μs, V_{DD} ≤ V_{(BR)DSS}, T_J ≤ 150°C

④ Pulse width ≤ 300μs; duty cycle ≤ 2%.

⑤ C_{oss eff.} is a fixed capacitance that gives the same charging time as C_{oss} while V_{DS} is rising from 0 to 80% V_{DS}

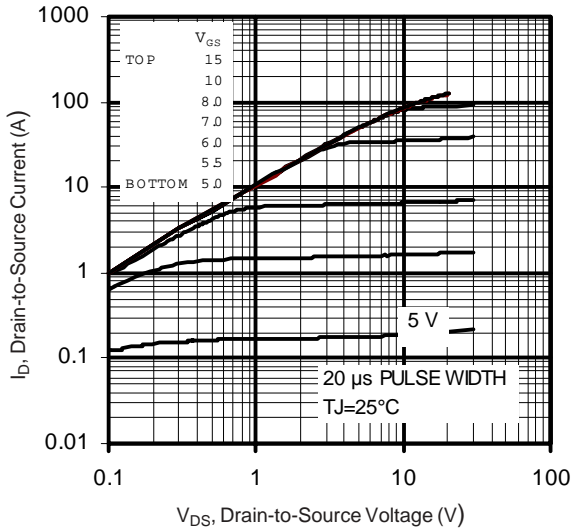

Fig 1. Typical Output Characteristics

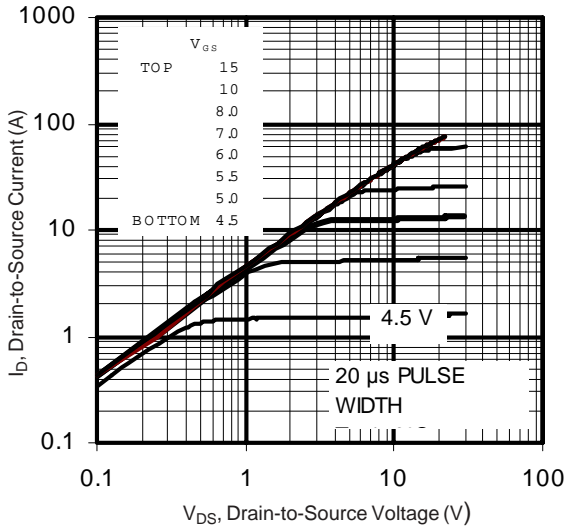

Fig 2. Typical Output Characteristics

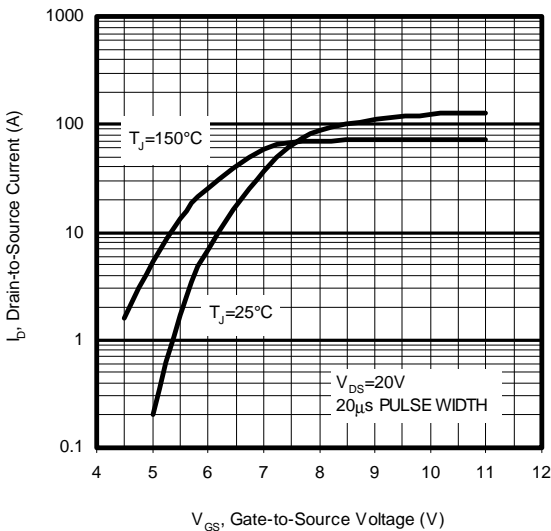

Fig 3. Typical Transfer Characteristics

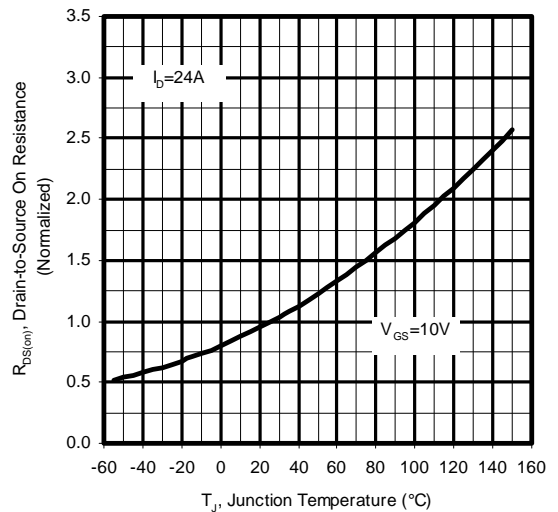

Fig 4. Normalized On-Resistance Vs. Temperature

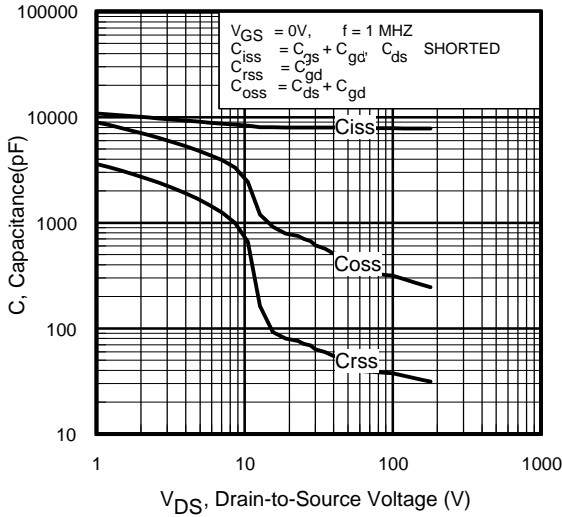

Fig 5. Typical Capacitance Vs. Drain-to-Source Voltage

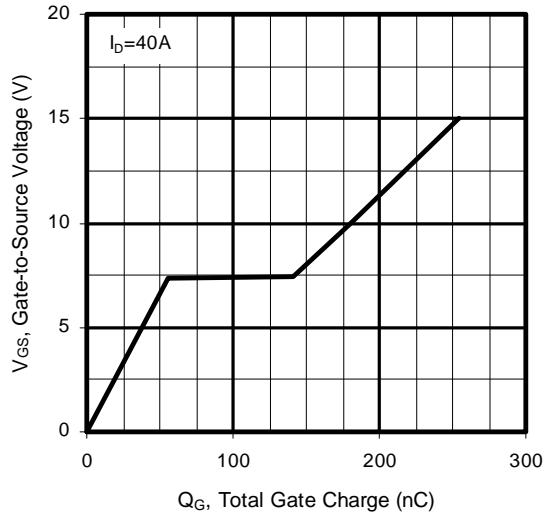

Fig 6. Typical Gate Charge Vs. Gate-to-Source Voltage

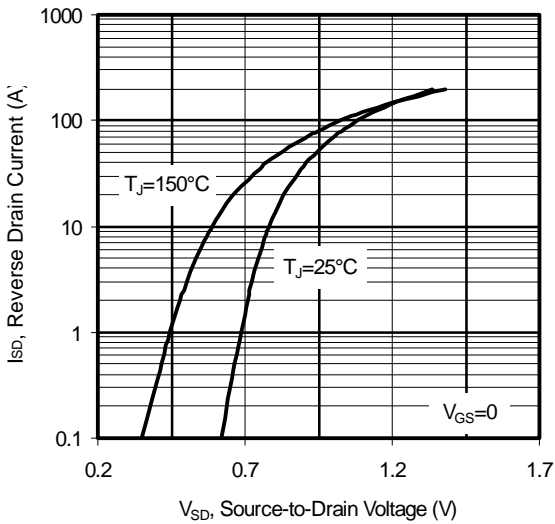

Fig 7. Typical Source-Drain Diode Forward Voltage

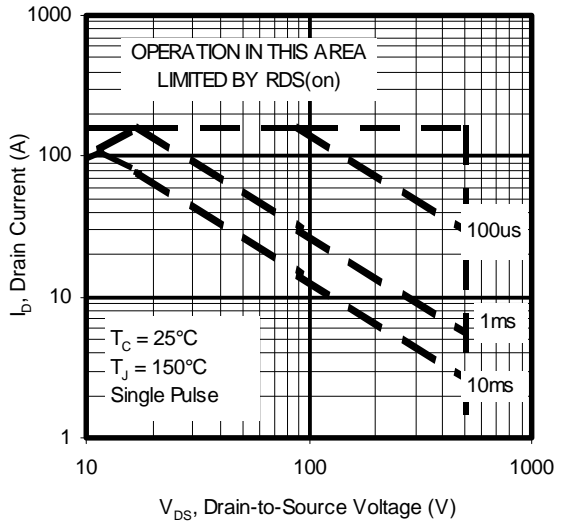

Fig 8. Maximum Safe Operating Area

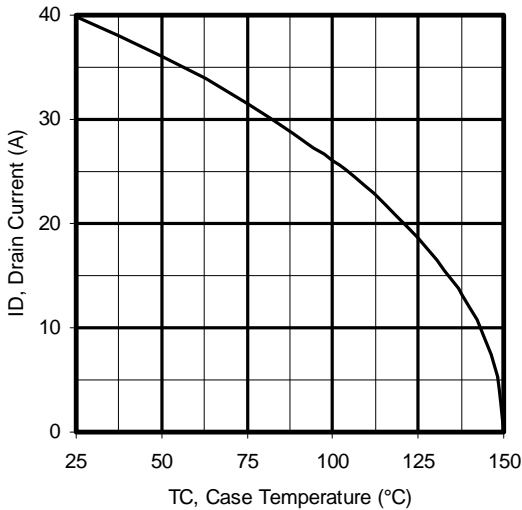

Fig 9. Maximum Drain Current Vs. Case Temperature

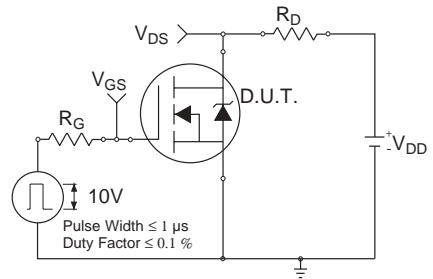

Fig 10a. Switching Time Test Circuit

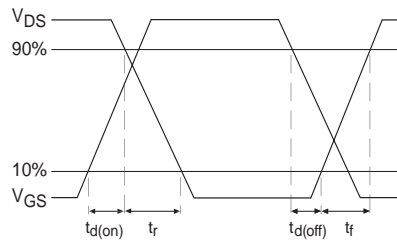

Fig 10b. Switching Time Waveforms

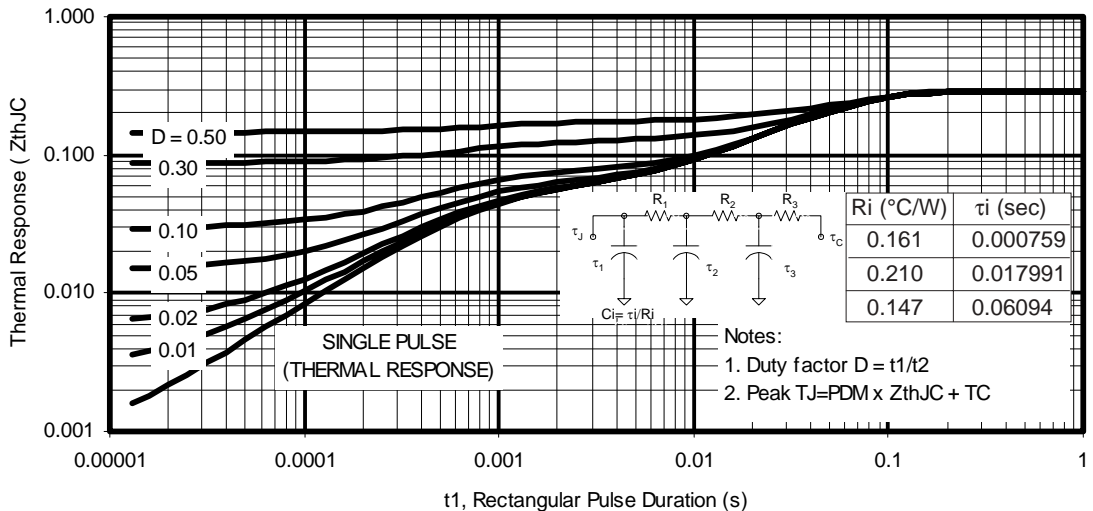

Fig 11. Maximum Effective Transient Thermal Impedance, Junction-to-Case

FC40SA50FK

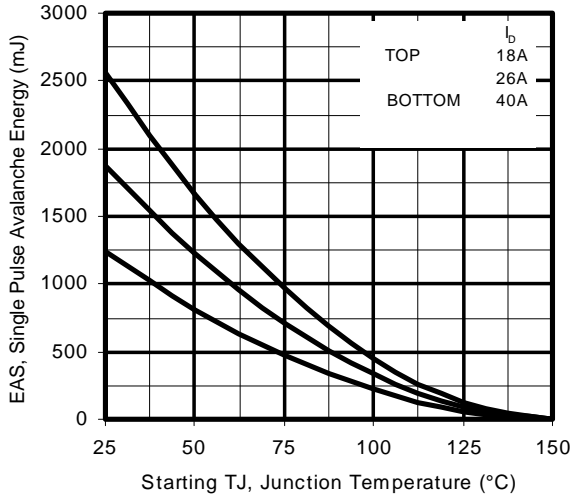

Fig 12a. Maximum Avalanche Energy Vs. Drain Current

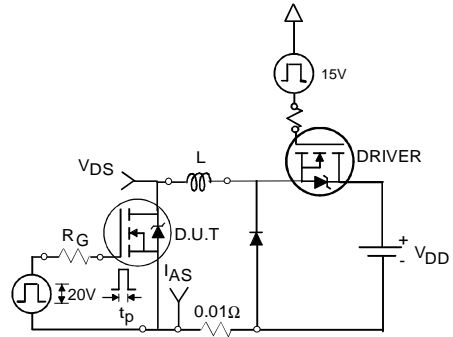

Fig 12c. Unclamped Inductive Test Circuit

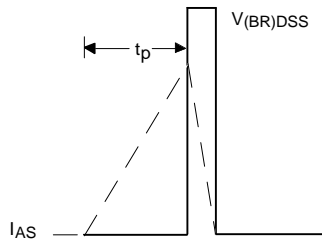

Fig 12d. Unclamped Inductive Waveforms

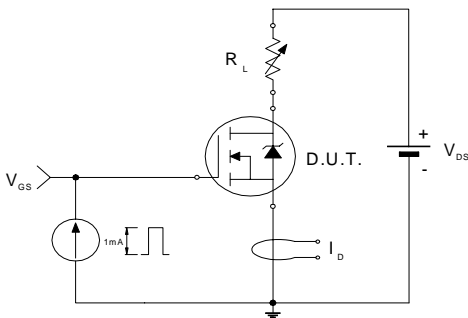

Fig 13a. Gate Charge Test Circuit

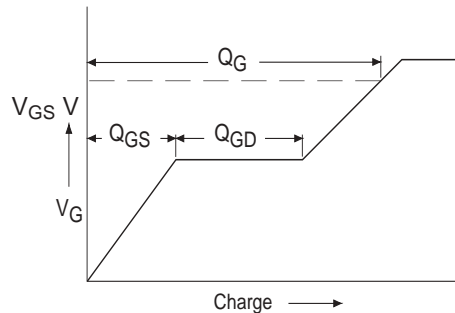
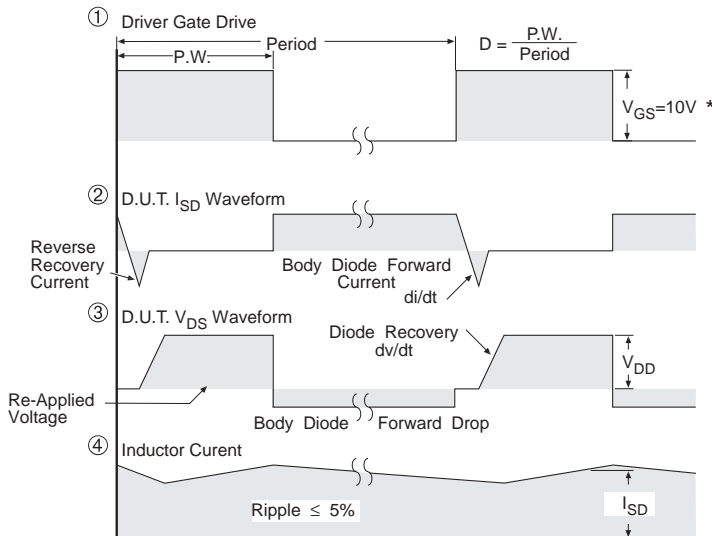
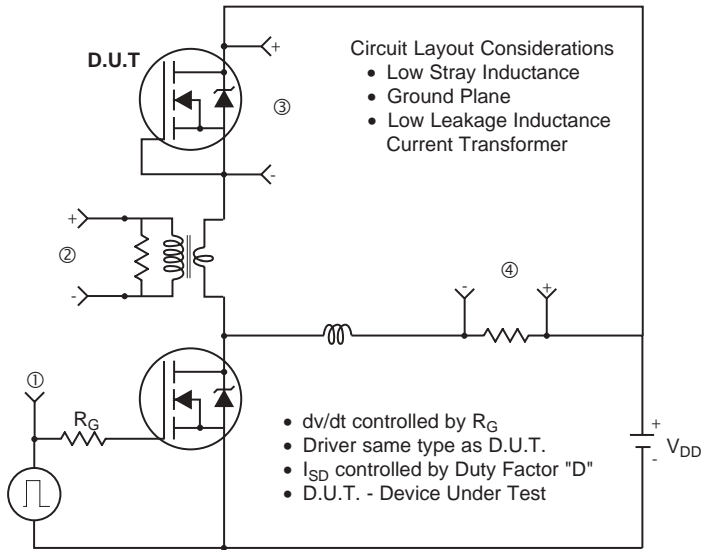

Fig 13b. Basic Gate Charge Waveform

Peak Diode Recovery dv/dt Test Circuit



* $V_{GS} = 5V$ for Logic Level Devices

Fig 14. For N-Channel HEXFET® Power MOSFETs

SOT-227 Package Details

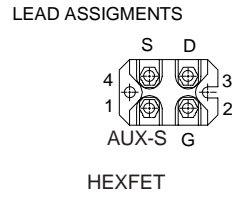
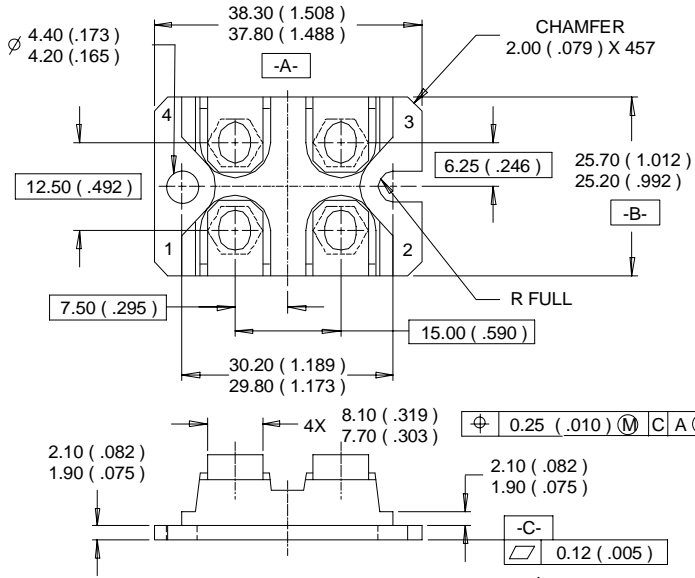

Note :
 AUX-S is a low current input
 intended for driving purpose only

QUANTITY PER TUBE IS 10
 M4 SCREW AND WASHER INCLUDED

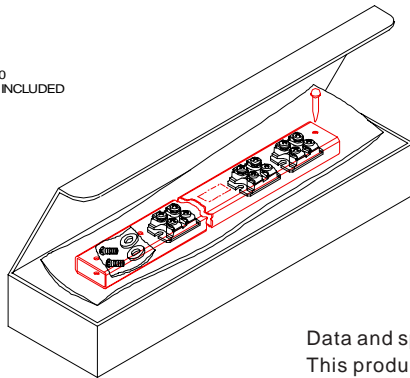

Data and specifications subject to change without notice.
 This product has been designed and qualified for Industrial
 Level.