

MITSUBISHI GATE COMMUTATED TURN-OFF THYRISTORS

**FGC4000BX-90DS**

HIGH POWER INVERTER USE  
PRESS PACK TYPE

**FGC4000BX-90DS**



- ITQRM Repetitive controllable on-state current ..... 4000A
- IT(AV) Average on-state current ..... 1200A
- VDRM Repetitive peak off state voltage ..... 4500V
- Anode short type

**OUTLINE DRAWING**

Dimensions in mm

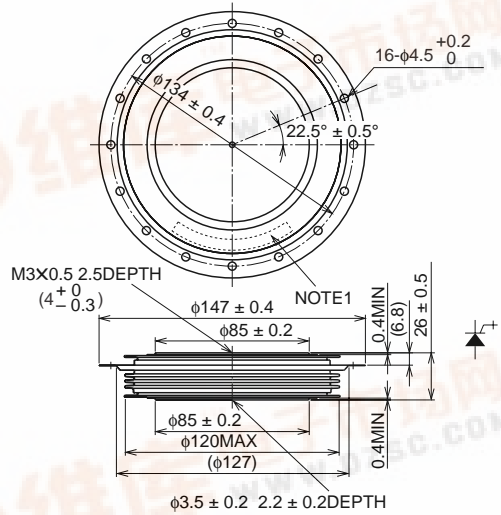

**APPLICATION**

Inverters, DC choppers, Induction heaters, DC to DC converters.

**MAXIMUM RATINGS**

Symbol	Parameter	Voltage class		Unit
		90DS		
VRRM	Repetitive peak reverse voltage	21		V
VRSM	Non-repetitive peak reverse voltage	21		V
VR(DC)	DC reverse voltage	21		V
VDRM	Repetitive peak off-state voltage*	4500		V
VDSM	Non-repetitive peak off-state voltage*	4500		V
VD(DC)	DC off-state voltage*	3600		V
VLTS	Long term DC stability voltage*	3000		V

\* : VGK = -2V

Symbol	Parameter	Conditions	Ratings	Unit
ITQRM	Repetitive controllable on-state current	(Snubberless) VDM = 4500V, VD = 2250V, LC = 0.2μH, VRG = 21V diG/dt = 6000A/μs. Tj = 25/125°C	4000	A
IT(RMS)	RMS on-state current	Applied for all conduction angles	1880	A
IT(AV)	Average on-state current	f = 60Hz, sinewave θ = 180°, Tf = 70°C	1200	A
ITSM	Surge on-state current	One half cycle at 60Hz, Tj = 125°C	25	kA
I <sup>2</sup> t	Current-squared, time integration		2.6 × 10 <sup>6</sup>	A <sup>2</sup> s
diT/dt	Critical rate of rise of on-state current	VD = 2250V, ITM = 4000A, IGM = 200A, Tj = 125°C diG/dt = 100A/μs (Snubberless)	1000	A/μs
VFGM	Peak forward gate voltage		10	V
VRGM	Peak reverse gate voltage		21	V
IFGM	Peak forward gate current		1000	A
IRGM	Peak reverse gate current		4000	A
PFGM	Peak forward gate power dissipation		10	kW
PRGM	Peak reverse gate power dissipation		120	kW
PFG(AV)	Average forward gate power dissipation		200	W
PRG(AV)	Average reverse gate power dissipation		6300	W
Tj	Junction temperature		-20 ~ +125	°C
Tstg	Storage temperature		-20 ~ +150	°C
—	Mounting force required	(Recommended value 40kN)	32 ~ 48	kN
—	Weight	Typical value	1500	g



# FGC4000BX-90DS

HIGH POWER INVERTER USE  
PRESS PACK TYPE

## ELECTRICAL CHARACTERISTICS

Symbol	Parameter	Test conditions	Limits			Unit
			Min	Typ	Max	
V <sub>TM</sub>	On-state voltage	I <sub>T</sub> = 4000A, T <sub>j</sub> = 125 C	—	—	4.0	V
I <sub>RRM</sub>	Repetitive peak reverse current	V <sub>RM</sub> = 21V, T <sub>j</sub> = 125 C	—	—	100	mA
I <sub>DRM</sub>	Repetitive peak off-state current	V <sub>DM</sub> = 4500V, V <sub>GK</sub> = -2V, T <sub>j</sub> = 125 C	—	—	150	mA
I <sub>GRM</sub>	Reverse gate current	V <sub>RG</sub> = 21V, T <sub>j</sub> = 125 C	—	—	100	mA
dv/dt	Critical rate of rise of off-state voltage	V <sub>D</sub> = 2250V, T <sub>j</sub> = 125 C, V <sub>GK</sub> = -2V (Expo. ware) (see Fig. 3)	3000	—	—	V/ns
t <sub>d</sub>	Turn-on delay	I <sub>T</sub> = 4000A, V <sub>D</sub> = 2250V, I <sub>GM</sub> = 200A, T <sub>j</sub> = 125 C di/dt = 1000A/ns, di <sub>G</sub> /dt = 100A/ns (Snubberless) (see Fig. 1)	—	—	3	ns
t <sub>s</sub>	Storage time	(Snubberless) I <sub>T</sub> = 4000A, V <sub>DM</sub> = 4500V, V <sub>D</sub> = 2250V	—	—	3	ns
I <sub>GQ</sub>	Peak gate turn-off current	di <sub>GQ</sub> /dt = 6000A/ns, C <sub>c</sub> = 6 nF, L <sub>c</sub> = 0.2nH V <sub>RG</sub> = 21V, T <sub>j</sub> = 125 C (see Fig. 2)	—	—	—	A
I <sub>GT</sub>	Gate trigger current	DC METHOD : V <sub>D</sub> = 24V, R <sub>L</sub> = 0.1W, T <sub>j</sub> = 25 C	—	—	4.0	A
V <sub>GT</sub>	Gate trigger voltage		—	—	1.5	V
R <sub>th(j-f)</sub>	Thermal resistance	Junction to fin	—	—	0.011	C/W

Fig.1 TURN-ON SWITCHING WAVEFORM AND TEST CIRCUIT

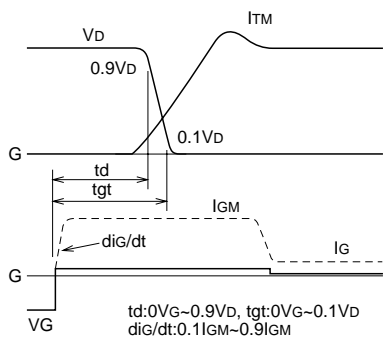

(1) TURN-ON SWITCHING WAVEFORM

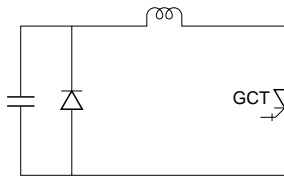

(2) TURN-ON TEST CIRCUIT

Fig.1 TURN-OFF SWITCHING WAVEFORM AND TEST CIRCUIT

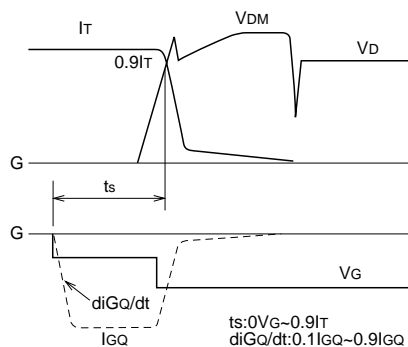

(1) TURN-OFF SWITCHING WAVEFORM

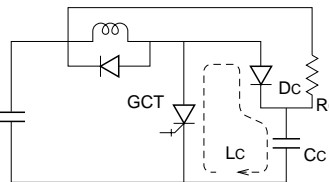

(2) TURN-OFF TEST CIRCUIT

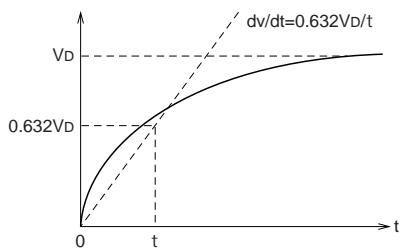

Fig.3 dv/dt TEST WAVEFORM

# FGC4000BX-90DS

HIGH POWER INVERTER USE  
PRESS PACK TYPE

## PERFORMANCE CURVES

**MAXIMUM ON-STATE CHARACTERISTIC**

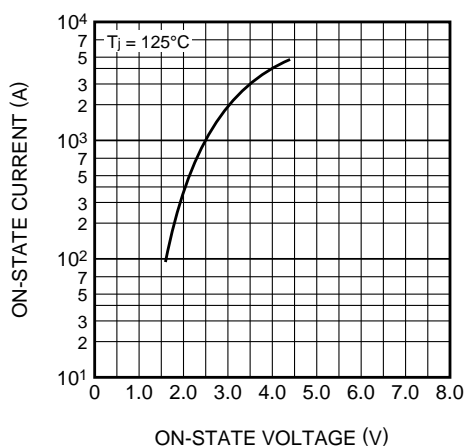

**RATED SURGE ON-STATE CURRENT**

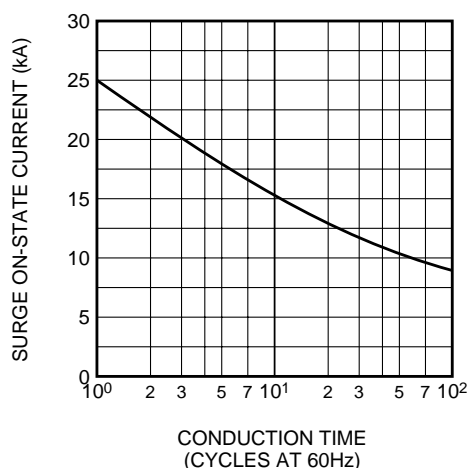

**GATE CHARACTERISTICS**

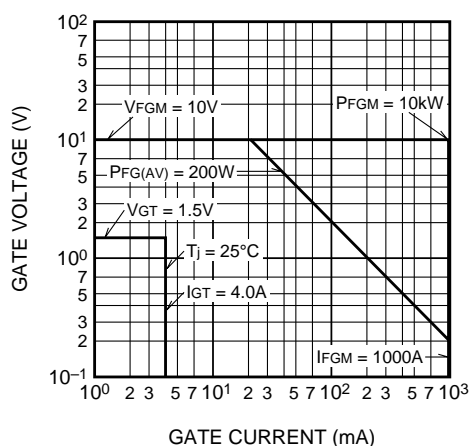

**MAXIMUM THERMAL IMPEDANCE CHARACTERISTIC (JUNCTION TO FIN)**

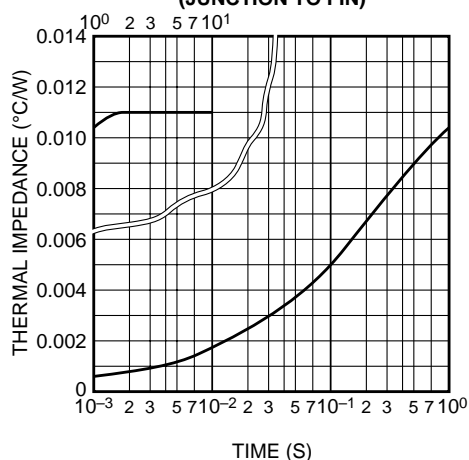

**MAXIMUM ON-STATE POWER DISSIPATION CHARACTERISTICS (SINGLE-PHASE HALF WAVE)**

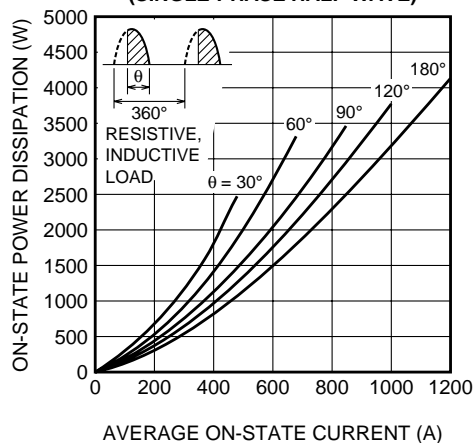

**ALLOWABLE FIN TEMPERATURE VS. AVERAGE ON-STATE CURRENT (SINGLE-PHASE HALF WAVE)**

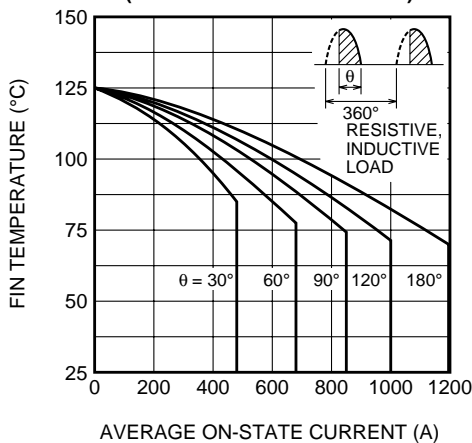

# FGC4000BX-90DS

HIGH POWER INVERTER USE  
PRESS PACK TYPE

