

SIEMENS

SFH636

HIGH SPEED 5.3 kV OPTOCOUPLER

Preliminary Data Sheet

FEATURES

- High Speed Optocoupler without Base Connection
- GaAIAs Emitter
- Integrated Detector with Photodiode and Transistor
- High Data Transmission Rate: 1 MBit/s
- TTL Compatible
- Open Collector Output
- CTR at $I_F=16\text{ mA}$, $V_O=0.4\text{ V}$, $V_{CC}=4.5\text{ V}$, $T_A=25^\circ\text{C}$: $\geq 19\%$
- Good CTR Linearity Relative to Forward Current
- Field Effect Stable by TRIOS[®] (TRansparent IOn Shield)
- Low Coupling Capacitance
- dV/dt : typ. $10\text{ kV}/\mu\text{s}$
- Isolation Test Voltage: $5300\text{ VAC}_{\text{RMS}}$
-  VDE 0884 Available with Option 1
- UL Approval, File #E52744

APPLICATIONS

- IGBT Drivers
- Data Communications
- Programmable Controllers

DESCRIPTION

The SFH636 is an optocoupler with a GaAIAs infrared emitting diode, optically coupled to an integrated photodetector consisting of a photodiode and a high speed transistor in a DIP-6 plastic package. The device is functionally similar to 6N136 except there is no base connection, and the electrical foot print is different. Noise and dV/dt performance is enhanced by not bringing out the base connection.

Signals can be transmitted between two electrically separated circuits up to frequencies of 2 MHz. The potential difference between the circuits to be coupled should not exceed the maximum permissible reference voltages.

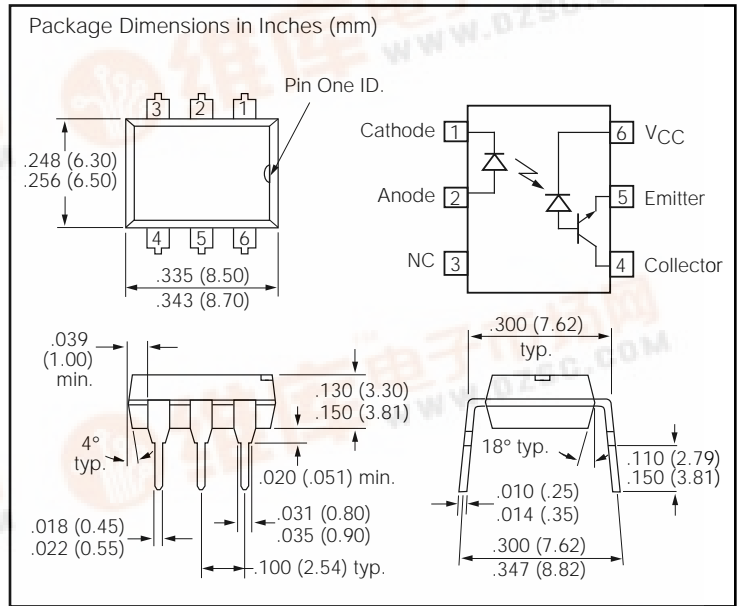

Absolute Maximum Ratings

Emitter (GaAIAs)

Reverse Voltage.....	3 V
DC Forward Current.....	25 mA
Surge Forward Current.....	1 A
$t_p \leq 1\ \mu\text{s}$, 300 pulses/sec.	
Total Power Dissipation.....	45 mW

Detector (Si Photodiode + Transistor)

Supply Voltage.....	-0.5 to 30 V
Output Voltage.....	-0.5 to 20 V
Output Current.....	8 mA
Total Power Dissipation.....	100 mW

Package Insulation

Isolation Test Voltage	
between emitter and detector	
(refer to climate DIN 40046, part 2, Nov. 74)	5300 VAC _{RMS}
Creepage.....	7 mm min.
Clearance	7 mm min.
Comparative Tracking Index	
per DIN IEC 112/VDE0303, part 1	175
Isolation Resistance	
$V_{IO}=500\text{ V}$, $T_A=25^\circ\text{C}$	$\geq 10^{12}\ \Omega$
$V_{IO}=500\text{ V}$, $T_A=100^\circ\text{C}$	$\geq 10^{11}\ \Omega$
Storage Temperature Range.....	-55 to +150°C
Ambient Temperature Range.....	-55 to +100°C
Junction Temperature	100°C
Soldering Temperature (t=10 sec. max.).....	260°C
Dip soldering: distance to seating plane $\geq 1.5\text{ mm}$	



Characteristics ($T_A=0^\circ$ to 70°C , unless otherwise specified, typical values $T_A=25^\circ\text{C}$)

Description	Symbol	Min.	Typ.	Max.	Unit
Emitter (IR GaAlAs)					
Forward Voltage, $I_F=16\text{ mA}$	V_F		1.5	1.8	V
Reverse Current, $V_R=3\text{ V}$	I_R		0.5	10	μA
Capacitance, $V_R=0\text{ V}$, $f=1\text{ MHz}$	C_0		125		pF
Thermal Resistance	R_{thJA}		700		$^\circ\text{K/W}$
Detector (Si Photodiode + Transistor)					
Supply Current, Logic High $I_F=0$, V_O (open), $V_{CC}=15\text{ V}$, $T_A=25^\circ\text{C}$ $I_F=0$, V_O (open), $V_{CC}=15\text{ V}$	I_{CCH}		0.01	1 2	μA
Output Current, Output High $I_F=0$, V_O (open), $V_{CC}=5.5\text{ V}$, $T_A=25^\circ\text{C}$ $I_F=0$, V_O (open), $V_{CC}=15\text{ V}$, $T_A=25^\circ\text{C}$ $I_F=0$, V_O (open), $V_{CC}=15\text{ V}$	I_{OH}		.003 .01 —	0.5 1 50	μA
Capacitance, $V_{CE}=5\text{ V}$, $f=1\text{ MHz}$	C_{CE}		3		pF
Thermal Resistance	R_{thJA}		300		$^\circ\text{K/W}$
Package					
Coupling Capacitance	C_C		0.6		pF
Coupling Transfer Ratio $I_F=16\text{ mA}$, $V_O=0.4\text{ V}$, $V_{CC}=4.5\text{ V}$, $T_A=25^\circ\text{C}$ $I_F=16\text{ mA}$, $V_O=0.5\text{ V}$, $V_{CC}=4.5\text{ V}$	I_C/I_F	19 15	30 —		%
Collector Emitter Saturation Voltage $I_F=16\text{ mA}$, $I_O=2.4\text{ mA}$, $V_{CC}=4.5\text{ V}$, $T_A=25^\circ\text{C}$	V_{OL}		0.1	0.4	V
Supply Current, Logic Low $I_F=16\text{ mA}$, V_O open, $V_{CC}=15\text{ V}$	I_{CCL}		80		μA

Figure 1. Test set-up

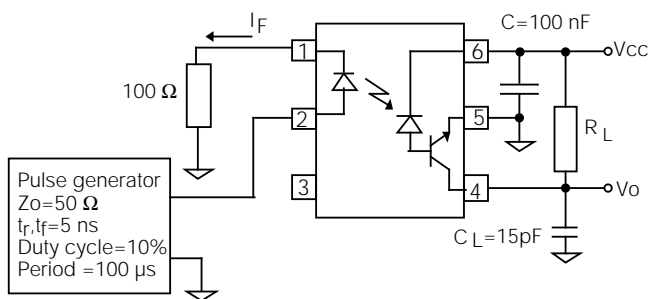
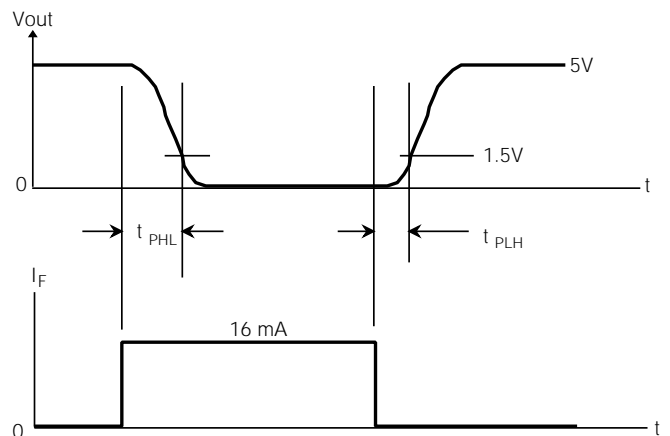

Figure 2. Switching time measurement



Description	Symbol	Min.	Typ.	Max.	Unit
Propagation Delay Time (High-Low) $I_F=16\text{ mA}$, $V_{CC}=5\text{ V}$, $R_L=1.9\text{ k}\Omega$, $T_A=25^\circ\text{C}$	t_{PHL}		0.3	0.8	μs
Propagation Delay Time (Low-High) $I_F=16\text{ mA}$, $V_{CC}=5\text{ V}$, $R_L=1.9\text{ k}\Omega$, $T_A=25^\circ\text{C}$	t_{PLH}		0.3	0.8	μs

Figure 3. Common mode transient test

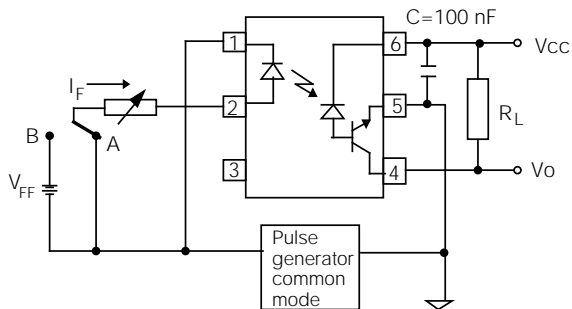
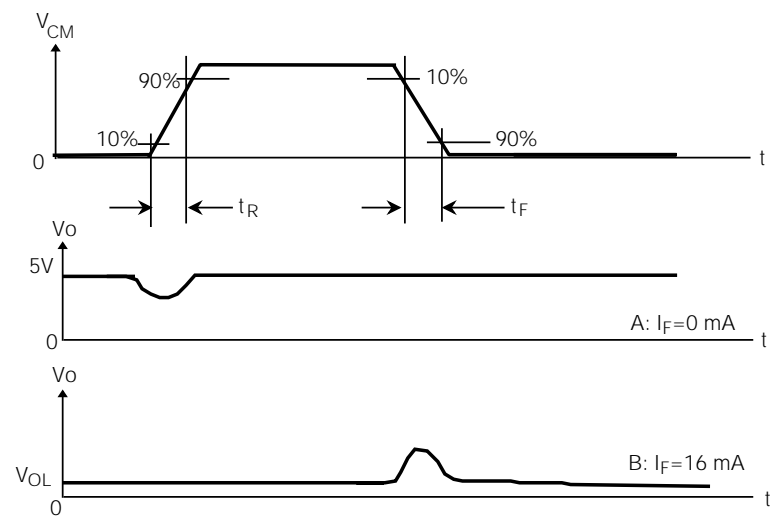

Figure 4. Measurement waveform of CMR



Description	Symbol	Min.	Typ.	Max.	Unit
Common Mode Transient Immunity (High) $I_F=0$, $V_{CM}=1500\text{ V}_{P-P}$, $R_L=1.9\text{ k}\Omega$, $V_{CC}=5\text{ V}$, $T_A=25^\circ\text{C}$	CM_H		10		$\text{kV}/\mu\text{s}$
Common Mode Transient Immunity (Low) $I_F=16\text{ mA}$, $V_{CM}=1500\text{ V}_{P-P}$, $R_L=1.9\text{ k}\Omega$, $V_{CC}=5\text{ V}$, $T_A=25^\circ\text{C}$	CM_L		10		$\text{kV}/\mu\text{s}$