



Programmable Timing Control Hub™ for Next Gen P4™ processor

Recommended Application:

CK409 48-pin part

Output Features:

- 2 - 0.7V current-mode differential CPU pairs
- 1 - 0.7V current-mode differential CPU pairs for ITP
- 1 - 0.7V current-mode differential SRC pair
- 9 - PCI (33MHz)
- 1 - USB, 48MHz
- 1 - DOT, 48MHz
- 2 - REF, 14.318MHz
- 3 - 3V66, 66.66MHz
- 1 - 3V66/VCH, selectable 48MHz or 66MHz

Key Specifications:

- CPU/SRC outputs cycle-cycle jitter < 125ps
- 3V66 outputs cycle-cycle jitter < 250ps
- PCI outputs cycle-cycle jitter < 250ps
- CPU outputs skew: < 100ps
- +/- 300ppm frequency accuracy on CPU & SRC clocks

Features/Benefits:

- Supports tight ppm accuracy clocks for Serial-ATA
- Supports spread spectrum modulation, 0 to -0.5% down spread and +/- 0.25% center spread
- Supports CPU clks up to 400MHz in test mode
- Uses external 14.318MHz crystal
- Supports undriven differential CPU, SRC pair in PD# for power management.

Functionality

FS2 B6b5	FS_A	FS_B	CPU MHz	SRC MHz	3V66 MHz	PCI MHz	REF MHz	USB/DOT MHz
0	0	0	100.00	100/200	66.66	33.33	14.318	48.00
	0	1	200.00	100/200	66.66	33.33	14.318	48.00
	1	0	133.33	100/200	66.66	33.33	14.318	48.00
	1	1	166.66	100/200	66.66	33.33	14.318	48.00
1	0	0	200.00	100/200	66.66	33.33	14.318	48.00
	0	1	400.00	100/200	66.66	33.33	14.318	48.00
	1	0	266.66	100/200	66.66	33.33	14.318	48.00
	1	1	333.33	100/200	66.66	33.33	14.318	48.00

Pin Configuration

Pin	Signal	Pin	Signal
*FSA/REF0	1	48	VDDA
*FSB/REF1	2	47	GND
VDDREF	3	46	IREF
X1	4	45	CPUCLKT_ITP
X2	5	44	CPUCLKC_ITP
GND	6	43	GND
PCICLK_F0	7	42	CPUCLKT1
PCICLK_F1	8	41	CPUCLKC1
PCICLK_F2	9	40	VDDCPU
VDDPCI	10	39	CPUCLKT0
GND	11	38	CPUCLKC0
PCICLK0	12	37	GND
PCICLK1	13	36	SRCCLKT
PCICLK2	14	35	SRCCLKC
PCICLK3	15	34	VDD
VDDPCI	16	33	Vtt_Pwrgd#
GND	17	32	SDATA
PCICLK4	18	31	SCLK
PCICLK5	19	30	3V66_0
PD#	20	29	3V66_1
48MHz_DOT	21	28	GND
48MHz_USB	22	27	VDD3V66
GND	23	26	3V66_2
VDD48	24	25	3V66_3/VCH

**120KW pull-down
48-pin SSOP



Pin Description

PIN #	PIN NAME	PIN TYPE	DESCRIPTION
1	*FSA/REF0	I/O	Frequency select latch input pin / 14.318 MHz reference clock.
2	*FSB/REF1	I/O	Frequency select latch input pin / 14.318 MHz reference clock.
3	VDDREF	PWR	Ref, XTAL power supply, nominal 3.3V
4	X1	IN	Crystal input, Nominally 14.318MHz.
5	X2	OUT	Crystal output, Nominally 14.318MHz
6	GND	PWR	Ground pin.
7	PCICLK_F0	OUT	Free running PCI clock not affected by PCI_STOP# .
8	PCICLK_F1	OUT	Free running PCI clock not affected by PCI_STOP# .
9	PCICLK_F2	OUT	Free running PCI clock not affected by PCI_STOP# .
10	VDDPCI	PWR	Power supply for PCI clocks, nominal 3.3V
11	GND	PWR	Ground pin.
12	PCICLK0	OUT	PCI clock output.
13	PCICLK1	OUT	PCI clock output.
14	PCICLK2	OUT	PCI clock output.
15	PCICLK3	OUT	PCI clock output.
16	VDDPCI	PWR	Power supply for PCI clocks, nominal 3.3V
17	GND	PWR	Ground pin.
18	PCICLK4	OUT	PCI clock output.
19	PCICLK5	OUT	PCI clock output.
20	PD#	IN	Asynchronous active low input pin, with 120Kohm internal pull-up resistor, used to power down the device. The internal clocks are disabled and the VCO and the crystal are stopped.
21	48MHz_DOT	OUT	48MHz clock output.
22	48MHz_USB	OUT	48MHz clock output.
23	GND	PWR	Ground pin.
24	VDD48	PWR	Power pin for the 48MHz output.3.3V

Pin Description (Continued)

PIN #	PIN NAME	PIN TYPE	DESCRIPTION
30	3V66_0	OUT	3.3V 66.66MHz clock output
25	3V66_3/VCH	OUT	3.3V 66.66MHz clock output / 48MHz VCH clock output.
26	3V66_2	OUT	3.3V 66.66MHz clock output
27	VDD3V66	PWR	Power pin for the 3.3V 66MHz clocks.
28	GND	PWR	Ground pin.
29	3V66_1	OUT	3.3V 66.66MHz clock output
30	3V66_0	OUT	3.3V 66.66MHz clock output
31	SCLK	IN	Clock pin of SMBus circuitry, 5V tolerant.
32	SDATA	I/O	Data pin for SMBus circuitry, 5V tolerant.
33	Vtt_Pwrgd#	IN	This 3.3V LVTTTL input is a level sensitive strobe used to determine when latch inputs are valid and are ready to be sampled. This is an active low input.
34	VDD	PWR	Power supply, nominal 3.3V
35	SRCCLKC	OUT	Complement clock of differential pair for S-ATA support. +/- 300ppm accuracy required.
36	SRCCLKT	OUT	True clock of differential pair for S-ATA support. +/- 300ppm accuracy required.
37	GND	PWR	Ground pin.
38	CPUCLKC0	OUT	Complementary clock of differential pair CPU outputs. These are current mode outputs. External resistors are required for voltage bias.
39	CPUCLKT0	OUT	True clock of differential pair CPU outputs. These are current mode outputs. External resistors are required for voltage bias.
40	VDDCPU	PWR	Supply for CPU clocks, 3.3V nominal
41	CPUCLKC1	OUT	Complementary clock of differential pair CPU outputs. These are current mode outputs. External resistors are required for voltage bias.
42	CPUCLKT1	OUT	True clock of differential pair CPU outputs. These are current mode outputs. External resistors are required for voltage bias.
43	GND	PWR	Ground pin.
44	CPUCLKC_ITP	OUT	Complementary clock of differential pair CPU outputs. These are current mode outputs. External resistors are required for voltage bias.
45	CPUCLKT_ITP	OUT	True clock of differential pair CPU outputs. These are current mode outputs. External resistors are required for voltage bias.
46	IREF	OUT	This pin establishes the reference current for the differential current-mode output pairs. This pin requires a fixed precision resistor tied to ground in order to establish the appropriate current. 475 ohms is the standard value.
47	GND	PWR	Ground pin.
48	VDDA	PWR	3.3V power for the PLL core.

General Description

ICS952606 is a 48 pin clock chip following Intel CK409 Yellow Cover specification. This clock synthesizer provides a single chip solution for next generation P4 Intel processors and Intel chipsets. **ICS952606** is driven with a 14.318MHz crystal. It generates CPU outputs up to 200MHz. It also provides a tight ppm accuracy output for Serial ATA support.

Block Diagram

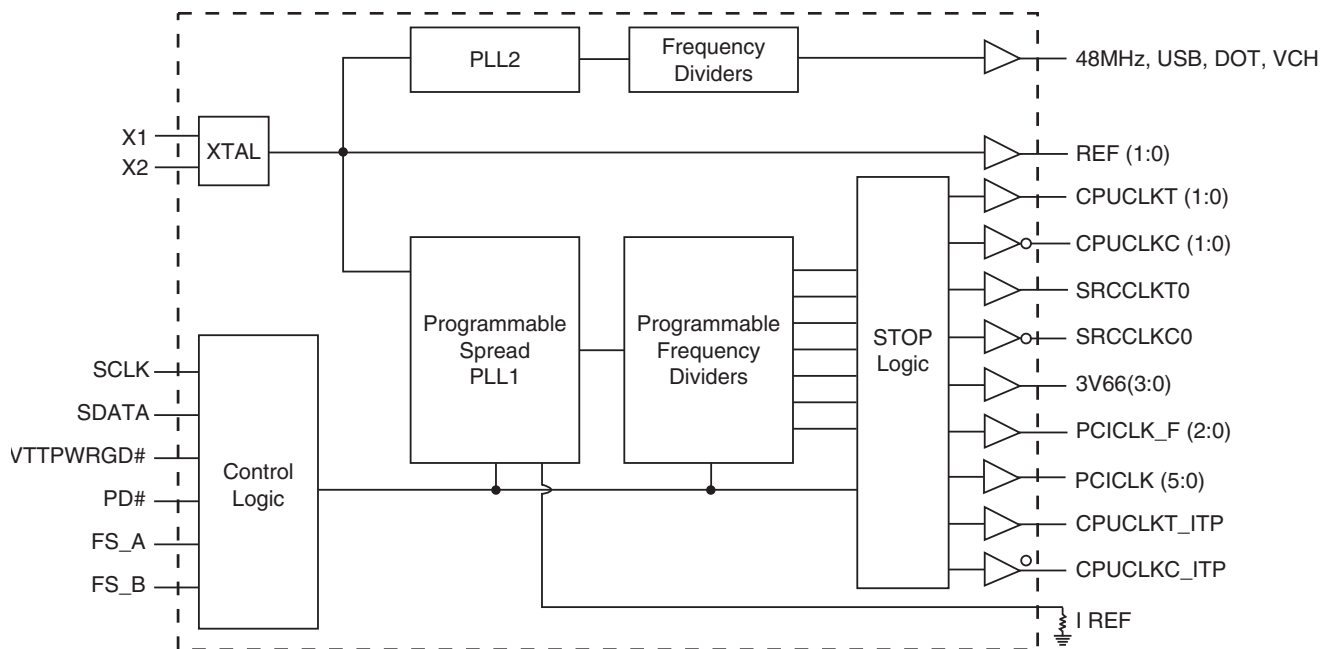

Power Groups

Pin Number		Description
VDD	GND	
3	6	Xtal, Ref
27	28	3V66 [0:3]
10,16	11,17	PCICLK outputs
34	37	SRCCLK outputs
48	47	Master clock, CPU Analog
24	23	48MHz, Fix Digital, Fix Analog
--	47	IREF
40	43	CPUCLK clocks

Absolute Max

Symbol	Parameter	Min	Max	Units
VDD_A	3.3V Core Supply Voltage		$V_{DD} + 0.5V$	V
VDD_In	3.3V Logic Input Supply Voltage	-0.5	$V_{DD} + 0.5V$	V
Ts	Storage Temperature	-65	150	°C
Tambient	Ambient Operating Temp	0	70	°C
Tcase	Case Temperature		115	°C
ESD prot	Input ESD protection human body model	2000		V

Electrical Characteristics - Input/Supply/Common Output Parameters

T_A = 0 - 70°C; Supply Voltage V_{DD} = 3.3 V +/-5%

PARAMETER	SYMBOL	CONDITIONS	MIN	TYP	MAX	UNITS	NOTES
Input High Voltage	V _{IH}	3.3V +/-5%	2		V _{DD} + 0.3	V	
Input Low Voltage	V _{IL}	3.3V +/-5%		V _{SS} - 0.3	0.8	V	
Input High Current	I _{IH}	V _{IN} = V _{DD}	-5		5	uA	
Input Low Current	I _{IL1}	V _{IN} = 0 V; Inputs with no pull-up resistors	-5			uA	
	I _{IL2}	V _{IN} = 0 V; Inputs with pull-up resistors	-200			uA	
Operating Supply Current	I _{DD3.3OP}	Full Active, C _L = Full load;		260.000	350	mA	
Powerdown Current	I _{DD3.3PD}	all diff pairs driven		31.000	35	mA	
		all differential pairs tri-stated		0.300	12	mA	
Input Frequency ³	F _i	V _{DD} = 3.3 V		14.31818		MHz	3
Pin Inductance ¹	L _{pin}				7	nH	1
Input Capacitance ¹	C _{IN}	Logic Inputs			5	pF	1
	C _{OUT}	Output pin capacitance			6	pF	1
	C _{INX}	X1 & X2 pins			5	pF	1
Clk Stabilization ^{1,2}	T _{STAB}	From VDD Power-Up or de-assertion of PD# to 1st clock.			1.8	ms	1,2
Modulation Frequency		Triangular Modulation	30		33	kHz	1
Tdrive_PD#		CPU output enable after PD# de-assertion			300	us	1
Tfall_Pd#		PD# fall time of			5	ns	1
Trise_Pd#		PD# rise time of			5	ns	2

¹Guaranteed by design, not 100% tested in production.

²See timing diagrams for timing requirements.

³Input frequency should be measured at the REF output pin and tuned to ideal 14.31818MHz to meet ppm frequency accuracy on PLL outputs.

Electrical Characteristics - CPU & SRC 0.7V Current Mode Differential Pair

$T_A = 0 - 70^\circ\text{C}$; $V_{DD} = 3.3\text{V} \pm 5\%$; $C_L = 2\text{pF}$

PARAMETER	SYMBOL	CONDITIONS	MIN	TYP	MAX	UNITS	NOTES
Current Source Output Impedance	Z_o^1	$V_o = V_x$	3000			Ω	1
Voltage High	VHigh	Statistical measurement on single ended signal using oscilloscope math function.	660	749	850	mV	1
Voltage Low	VLow		-150	3	150		1
Max Voltage	Vovs	Measurement on single ended signal using absolute value.		756	1150	mV	1
Min Voltage	Vuds		-300	-7			1
Crossing Voltage (abs)	Vcross(abs)		250	350	550	mV	1
Crossing Voltage (var)	d-Vcross	Variation of crossing over all edges		12	140	mV	1
Long Accuracy	ppm	see Tperiod min-max values	-300		300	ppm	1,2
Average period	Tperiod	200MHz nominal	4.9985	5.000	5.0015	ns	2
		200MHz spread	4.9985		5.0266	ns	2
		166.66MHz nominal	5.9982	6.000	6.0018	ns	2
		166.66MHz spread	5.9982		6.0320	ns	2
		133.33MHz nominal	7.4978	7.500	7.5023	ns	2
		133.33MHz spread	7.4978		5.4000	ns	2
		100.00MHz nominal	9.9970	10.000	10.0030	ns	2
		100.00MHz spread	9.9970		10.0533	ns	2
Absolute min period	T_{absmin}	200MHz nominal	4.8735			ns	1,2
		166.66MHz nominal/spread	5.8732			ns	1,2
		133.33MHz nominal/spread	7.3728			ns	1,2
		100.00MHz nominal/spread	9.8720			ns	1,2
Rise Time	t_r	$V_{OL} = 0.175\text{V}$, $V_{OH} = 0.525\text{V}$	175	279	700	ps	1
Fall Time	t_f	$V_{OH} = 0.525\text{V}$, $V_{OL} = 0.175\text{V}$	175	280	700	ps	1
Rise Time Variation	d- t_r			30	125	ps	1
Fall Time Variation	d- t_f			30	125	ps	1
Duty Cycle	d_{i3}	Measurement from differential waveform	45	50.9	55	%	1
Skew	t_{sk3}	$V_T = 50\%$		8	100	ps	1
Jitter, Cycle to cycle	$t_{jycyc-cyc}$	Measurement from differential waveform		40	125	ps	1

¹Guaranteed by design, not 100% tested in production.

²All Long Term Accuracy and Clock Period specifications are guaranteed with the assumption that Ref output is at 14.31818MHz

SRC clock outputs run at only 100MHz or 200MHz, specs for 133.33 and 166.66 do not apply to SRC clock pair.

Electrical Characteristics - 3V66 Mode: 3V66 [3:0]
 $T_A = 0 - 70^\circ\text{C}$; $V_{DD} = 3.3\text{V} \pm 5\%$; $C_L = 10\text{-}30\text{ pF}$ (unless otherwise specified)

PARAMETER	SYMBOL	CONDITIONS	MIN	TYP	MAX	UNITS	Notes
Long Accuracy	ppm	see Tperiod min-max values	-300		300	ppm	1,2
Clock period	T_{period}	66.66MHz output nominal	14.9955	15	15.0045	ns	2
		66.66MHz output spread	14.9955		15.0799	ns	2
Output High Voltage	V_{OH}	$I_{OH} = -1\text{ mA}$	2.4			V	
Output Low Voltage	V_{OL}	$I_{OL} = 1\text{ mA}$			0.55	V	
Output High Current	I_{OH}	$V_{OH@MIN} = 1.0\text{ V}$	-33			mA	
		$V_{OH@MAX} = 3.135\text{ V}$			-33	mA	
Output Low Current	I_{OL}	$V_{OL@MIN} = 1.95\text{ V}$	30			mA	
		$V_{OL@MAX} = 0.4\text{ V}$			38	mA	
Edge Rate		Rising edge rate	1		4	V/ns	1
Edge Rate		Falling edge rate	1		4	V/ns	1
Rise Time	t_{r1}	$V_{OL} = 0.4\text{ V}$, $V_{OH} = 2.4\text{ V}$	0.5	1.79	2	ns	1
Fall Time	t_{f1}	$V_{OH} = 2.4\text{ V}$, $V_{OL} = 0.4\text{ V}$	0.5	1.69	2	ns	1
Duty Cycle	d_{t1}	$V_T = 1.5\text{ V}$	45	49.9	55	%	1
Skew	t_{sk1}	$V_T = 1.5\text{ V}$		80	250	ps	1
Jitter	$t_{jyc-cyc}$	$V_T = 1.5\text{ V}$ 3V66		172	250	ps	1

¹Guaranteed by design, not 100% tested in production.

²All Long Term Accuracy and Clock Period specifications are guaranteed with the assumption that Ref output is at 14.31818MHz

Electrical Characteristics - PCICLK
 $T_A = 0 - 70^\circ\text{C}$; $V_{DD} = 3.3\text{V} \pm 5\%$; $C_L = 10\text{-}30\text{ pF}$ (unless otherwise specified)

PARAMETER	SYMBOL	CONDITIONS	MIN	TYP	MAX	UNITS	Notes
Long Accuracy	ppm	see Tperiod min-max values	-300		300	ppm	1,2
Clock period	T_{period}	33.33MHz output nominal	29.9910	30	30.0090	ns	2
		33.33MHz output spread	29.9910		30.1598	ns	2
Output High Voltage	V_{OH}	$I_{OH} = -1\text{ mA}$	2.4			V	
Output Low Voltage	V_{OL}	$I_{OL} = 1\text{ mA}$			0.55	V	
Output High Current	I_{OH}	$V_{OH@MIN} = 1.0\text{ V}$	-33			mA	
		$V_{OH@MAX} = 3.135\text{ V}$			-33	mA	
Output Low Current	I_{OL}	$V_{OL@MIN} = 1.95\text{ V}$	30			mA	
		$V_{OL@MAX} = 0.4\text{ V}$			38	mA	
Edge Rate		Rising edge rate	1		4	V/ns	1
Edge Rate		Falling edge rate	1		4	V/ns	1
Rise Time	t_{r1}	$V_{OL} = 0.4\text{ V}$, $V_{OH} = 2.4\text{ V}$	0.5	1.79	2	ns	1
Fall Time	t_{f1}	$V_{OH} = 2.4\text{ V}$, $V_{OL} = 0.4\text{ V}$	0.5	1.69	2	ns	1
Duty Cycle	d_{t1}	$V_T = 1.5\text{ V}$	45	51.2	55	%	1
Skew	t_{sk1}	$V_T = 1.5\text{ V}$		59	500	ps	1
Jitter	$t_{jyc-cyc}$	$V_T = 1.5\text{ V}$ 3V66		140	250	ps	1

¹Guaranteed by design, not 100% tested in production.

²All Long Term Accuracy and Clock Period specifications are guaranteed with the assumption that Ref output is at 14.31818MHz

Electrical Characteristics - 48MHz DOT Clock

$T_A = 0 - 70^\circ\text{C}$; $V_{DD} = 3.3\text{V} \pm 5\%$; $C_L = 5\text{-}10\text{ pF}$ (unless otherwise specified)

PARAMETER	SYMBOL	CONDITIONS	MIN	TYP	MAX	UNITS	Notes
Long Accuracy	ppm	see T _{period} min-max values	-200		200	ppm	1,2
Clock period	T _{period}	48.008 MHz output nominal	20.8257		20.8340	ns	2
Output High Voltage	V _{OH}	I _{OH} = -1 mA	2.4			V	
Output Low Voltage	V _{OL}	I _{OL} = 1 mA			0.55	V	
Output High Current	I _{OH}	V _{OH@MIN} = 1.0 V	-33			mA	
		V _{OH@MAX} = 3.135 V			-33	mA	
Output Low Current	I _{OL}	V _{OL@MIN} = 1.95 V	30			mA	
		V _{OL@MAX} = 0.4 V			38	mA	
Edge Rate		Rising edge rate	2		4	V/ns	1
Edge Rate		Falling edge rate	2		4	V/ns	1
Rise Time	t _{r1}	V _{OL} = 0.4 V, V _{OH} = 2.4 V	0.5	0.87	1	ns	1
Fall Time	t _{f1}	V _{OH} = 2.4 V, V _{OL} = 0.4 V	0.5	0.89	1	ns	1
Duty Cycle	d _{t1}	V _T = 1.5 V	45	52.3	55	%	1
Long Term Jitter		125us period jitter (8kHz frequency modulation amplitude)		0.64	2	ns	1

¹Guaranteed by design, not 100% tested in production.

²All Long Term Accuracy and Clock Period specifications are guaranteed with the assumption that Ref output is at 14.31818MHz

Electrical Characteristics - VCH, 48MHz, 48MHz, USB

$T_A = 0 - 70^\circ\text{C}$; $V_{DD} = 3.3\text{V} \pm 5\%$; $C_L = 10\text{-}20\text{ pF}$ (unless otherwise specified)

PARAMETER	SYMBOL	CONDITIONS	MIN	TYP	MAX	UNITS	Notes
Long Accuracy	ppm	see Tperiod min-max values	-200		200	ppm	1,2
Clock period	T_{period}	48.008 MHz output nominal	20.8257		20.8340	ns	2
Output High Voltage	V_{OH}	$I_{OH} = -1\text{ mA}$	2.4			V	
Output Low Voltage	V_{OL}	$I_{OL} = 1\text{ mA}$			0.55	V	
Output High Current	I_{OH}	$V_{OH@MIN} = 1.0\text{ V}$	-33			mA	
		$V_{OH@MAX} = 3.135\text{ V}$			-33	mA	
Output Low Current	I_{OL}	$V_{OL@MIN} = 1.95\text{ V}$	30			mA	
		$V_{OL@MAX} = 0.4\text{ V}$			38	mA	
Edge Rate		Rising edge rate	1		2	V/ns	1
Edge Rate		Falling edge rate	1		2	V/ns	1
Rise Time	t_{r1}	$V_{OL} = 0.4\text{ V}$, $V_{OH} = 2.4\text{ V}$	1	1.45	2	ns	1
Fall Time	t_{f1}	$V_{OH} = 2.4\text{ V}$, $V_{OL} = 0.4\text{ V}$	1	1.37	2	ns	1
Duty Cycle	d_{t1}	$V_T = 1.5\text{ V}$	45	52.5	55	%	1
Long Term Jitter		125us period jitter (8kHz frequency modulation amplitude)		0.63	6	ns	1

¹Guaranteed by design, not 100% tested in production.

² All Long Term Accuracy and Clock Period specifications are guaranteed with the assumption that Ref output is at 14.31818MHz

Electrical Characteristics - REF-14.318MHz

$T_A = 0 - 70^\circ\text{C}$; $V_{DD} = 3.3\text{V} \pm 5\%$; $C_L = 10\text{-}20\text{ pF}$ (unless otherwise specified)

PARAMETER	SYMBOL	CONDITIONS	MIN	TYP	MAX	UNITS	Notes
Long Accuracy	ppm	see Tperiod min-max values	-300		300	ppm	1
Clock period	T_{period}	14.31818 MHz output nominal	69.8270		69.8550	ns	
Output High Voltage	V_{OH}^1	$I_{OH} = -1\text{ mA}$	2.4			V	
Output Low Voltage	V_{OL}^1	$I_{OL} = 1\text{ mA}$			0.4	V	
Output High Current	I_{OH}^1	$V_{OH@MIN} = 1.0\text{ V}$, $V_{OH@MAX} = 3.135\text{ V}$	-29		-23	mA	
Output Low Current	I_{OL}^1	$V_{OL@MIN} = 1.95\text{ V}$, $V_{OL@MAX} = 0.4\text{ V}$	29		27	mA	
Rise Time	t_{r1}^1	$V_{OL} = 0.4\text{ V}$, $V_{OH} = 2.4\text{ V}$	1	1.93	2	ns	1
Fall Time	t_{f1}^1	$V_{OH} = 2.4\text{ V}$, $V_{OL} = 0.4\text{ V}$	1	1.92	2	ns	1
Skew	t_{sk1}^1	$V_T = 1.5\text{ V}$		14	500	ps	1
Duty Cycle	d_{t1}^1	$V_T = 1.5\text{ V}$	45	53.8	55	%	1
Jitter	$t_{jvc-cvc}^1$	$V_T = 1.5\text{ V}$		400	1000	ps	1

¹Guaranteed by design, not 100% tested in production.

Group to Group Skews at Common Transition Edges

GROUP	SYMBOL	CONDITIONS	MIN	TYP	MAX	UNITS
3V66 to PCI	$S_{3V66-PCI}$	3V66 (3:0) leads 33MHz PCI	1.50	2	3.50	ns
DOT-USB	S_{DOT_USB}	180 degrees out of phase	0.00		1.00	ns
DOT-VCH	S_{DOT_VCH}	in phase	0.00		1.00	ns

General I²C serial interface information for the ICS952606

How to Write:

- Controller (host) sends a start bit.
- Controller (host) sends the write address D2_(H)
- ICS clock will **acknowledge**
- Controller (host) sends the beginning byte location = N
- ICS clock will **acknowledge**
- Controller (host) sends the data byte count = X
- ICS clock will **acknowledge**
- Controller (host) starts sending **Byte N through Byte N + X - 1**
(see Note 2)
- ICS clock will **acknowledge** each byte **one at a time**
- Controller (host) sends a Stop bit

How to Read:

- Controller (host) will send start bit.
- Controller (host) sends the write address D2_(H)
- ICS clock will **acknowledge**
- Controller (host) sends the beginning byte location = N
- ICS clock will **acknowledge**
- Controller (host) will send a separate start bit.
- Controller (host) sends the read address D3_(H)
- ICS clock will **acknowledge**
- ICS clock will send the data byte count = X
- ICS clock sends **Byte N + X - 1**
- ICS clock sends **Byte 0 through byte X (if X_(H) was written to byte 8).**
- Controller (host) will need to acknowledge each byte
- Controller (host) will send a not acknowledge bit
- Controller (host) will send a stop bit

Index Block Write Operation			
Controller (Host)		ICS (Slave/Receiver)	
T	starT bit		
Slave Address D2 _(H)			
WR	WRite		
		ACK	
Beginning Byte = N			
		ACK	
Data Byte Count = X			
		ACK	
Beginning Byte N		X Byte	
			ACK
○			○
○			○
○			○
Byte N + X - 1			ACK
P	stoP bit		

Index Block Read Operation			
Controller (Host)		ICS (Slave/Receiver)	
T	starT bit		
Slave Address D2 _(H)			
WR	WRite		
		ACK	
Beginning Byte = N			
		ACK	
RT	Repeat starT		
Slave Address D3 _(H)			
RD	ReaD		
		ACK	
		Data Byte Count = X	
ACK		X Byte	
ACK			Beginning Byte N
○			○
○			○
○			○
			Byte N + X - 1
N	Not acknowledge		
P	stoP bit		



I²C Table: Read-Back Register

Byte 0	Pin #	Name	Control Function	Type	0	1	PWD
Bit 7	-	RESERVED	RESERVED	-	RESERVED		X
Bit 6	-	RESERVED		-	RESERVED		X
Bit 5	-	RESERVED		-	RESERVED		X
Bit 4	-	RESERVED		R	RESERVED		X
Bit 3	-	RESERVED		R	RESERVED		X
Bit 2	-	RESERVED		R	RESERVED		X
Bit 1	-	FSB	Freq Select 1 Read Back	R	READBACK of CPU(2:0) Frequency		X
Bit 0	-	FSA	Freq Select 0 Read Back	R			X

I²C Table: Spreading and Device Behavior Control Register

Byte 1	Pin #	Name	Control Function	Type	0	1	PWD
Bit 7		SRC/SRC#	SRC Free-Running Control	RW	FREE-RUN	STOPPABLE	0
Bit 6		SRC	Output Control	RW	Disable	Enable	1
Bit 5		RESERVED		R	RESERVED		X
Bit 4		RESERVED		R	RESERVED		X
Bit 3		RESERVED		R	RESERVED		X
Bit 2		RESERVED		R	RESERVED		X
Bit 1		CPUT1/CPUC1	Output Control	RW	Disable	Enable	1
Bit 0		CPUT0/CPUC0	Output Control	RW	Disable	Enable	1

I²C Table: Output Control Register

Byte 2	Pin #	Name	Control Function	Type	0	1	PWD
Bit 7		SRC_PD# Drive Mode	0: Driven in PD#	RW	Driven	Hi-Z	0
Bit 6		SRC_Stop# Drive Mode	0: Driven in PCI_Stop# (byte3bit7)	RW	Driven	Hi-Z	0
Bit 5		RESERVED	RESERVED	-	RESERVED		X
Bit 4		CPUT1_PD# Drive Mode	0: driven in PD#	RW	Driven	Hi-Z	0
Bit 3		CPUT0_PD# Drive Mode	1: Tri-stated	RW	Driven	Hi-Z	0
Bit 2		RESERVED	RESERVED	-	RESERVED		X
Bit 1		RESERVED	RESERVED	-	RESERVED		X
Bit 0		RESERVED	RESERVED	-	RESERVED		X

I²C Table: Output Control Register

Byte 3	Pin #	Name	Control Function	Type	0	1	PWD
Bit 7		PCI_Stop#	PCI_Stop# Control 0:all stoppable PCI are stopped	RW	Enable	Disable	1
Bit 6		RESERVED	RESERVED	-	RESERVED		X
Bit 5		PCICLK5	Output Control	RW	Disable	Enable	1
Bit 4		PCICLK4	Output Control	RW	Disable	Enable	1
Bit 3		PCICLK3	Output Control	RW	Disable	Enable	1
Bit 2		PCICLK2	Output Control	RW	Disable	Enable	1
Bit 1		PCICLK1	Output Control	RW	Disable	Enable	1
Bit 0		PCICLK0	Output Control	RW	Disable	Enable	1



I²C Table: Output Control Register

Byte 4	Pin #	Name	Control Function	Type	0	1	PWD
Bit 7		48MHz_USB 2x output drive	0=2x drive	RW	2x drive	normal	1
Bit 6		48MHz_USB	Output Control	RW	Disable	Enable	1
Bit 5		RESERVED	RESERVED	-	RESERVED		X
Bit 4		RESERVED	RESERVED	-	RESERVED		X
Bit 3		RESERVED	RESERVED	-	RESERVED		X
Bit 2		PCICKF2	Output Control	RW	Stoppable	Free-run	1
Bit 1		PCICKF1	Output Control	RW	Stoppable	Free-run	1
Bit 0		PCICKF0	Output Control	RW	Stoppable	Free-run	1

I²C Table: Output Control Register

Byte 5	Pin #	Name	Control Function	Type	0	1	PWD
Bit 7		DOT_48MHZ	Output Control	RW	Disable	Enable	1
Bit 6		CPU_T/C_ITP	Output Control	RW	Disable	Enable	1
Bit 5		3V66_3/VHC Select	Output Select	RW	3V66	VCH	0
Bit 4		3V66_3/VHC	Output Control	RW	Disable	Enable	1
Bit 3		RESERVED	RESERVED	-	RESERVED		X
Bit 2		3V66_2	Output Control	RW	Disable	Enable	1
Bit 1		3V66_1	Output Control	RW	Disable	Enable	1
Bit 0		3V66_0	Output Control	RW	Disable	Enable	1

I²C Table: Output Control and Fix Frequency Register

Byte 6	Pin #	Name	Control Function	Type	0	1	PWD
Bit 7		Test Clock Mode	Test Clock Mode	-	Disable	Enable	0
Bit 6		RESERVED	-	-	-	-	0
Bit 5		CPU *2 Test Clock	FS_A and FS_B Operation	-	Normal	Test Mode	0
Bit 4		SRC Frequency Select	SRC Frequency Select	-	100MHz	200MHz	0
Bit 3		Spread Spectrum Type	Down/Center	-	Down	Center	0
Bit 2		Spread Spectrum Mode	Spread Spectrum Enable	-	Spread OFF	Spread ON	0
Bit 1		REF1	Output Control	RW	Disable	Enable	1
Bit 0		REF0	Output Control	RW	Disable	Enable	1

I²C Table: Vendor & Revision ID Register

Byte 7	Pin #	Name	Control Function	Type	0	1	PWD
Bit 7	-	RID3	REVISION ID	R	-	-	0
Bit 6	-	RID2		R	-	-	0
Bit 5	-	RID1		R	-	-	0
Bit 4	-	RID0		R	-	-	0
Bit 3	-	VID3	VENDOR ID	R	-	-	0
Bit 2	-	VID2		R	-	-	0
Bit 1	-	VID1		R	-	-	0
Bit 0	-	VID0		R	-	-	1



I²C Table: Byte Count Register

Byte 8	Pin #	Name	Control Function	Type	0	1	PWD
Bit 7	-	BC7	Writing to this register will configure how many bytes will be read back, default is 08 = 8 bytes.	RW	-	-	0
Bit 6	-	BC6		RW	-	-	0
Bit 5	-	BC5		RW	-	-	0
Bit 4	-	BC4		RW	-	-	0
Bit 3	-	BC3		RW	-	-	1
Bit 2	-	BC2		RW	-	-	0
Bit 1	-	BC1		RW	-	-	0
Bit 0	-	BC0		RW	-	-	0

I²C Table: Reserved

Byte 9	Pin #	Name	Control Function	Type	0	1	PWD
Bit 7	-	RESERVED	RESERVED	-	RESERVED		X
Bit 6	-	RESERVED	RESERVED	-	RESERVED		X
Bit 5	-	RESERVED	RESERVED	-	RESERVED		X
Bit 4	-	RESERVED	RESERVED	-	RESERVED		X
Bit 3	-	RESERVED	RESERVED	-	RESERVED		X
Bit 2	-	RESERVED	RESERVED	-	RESERVED		X
Bit 1	-	RESERVED	RESERVED	-	RESERVED		X
Bit 0	-	RESERVED	RESERVED	-	RESERVED		X

I²C Table: Reserved

Byte 10	Pin #	Name	Control Function	Type	0	1	PWD
Bit 7	-	M/N prog Enable	M/N prog Enable	-	Disable	Enable	0
Bit 6	-	RESERVED	RESERVED	-	RESERVED		X
Bit 5	-	RESERVED	RESERVED	-	RESERVED		X
Bit 4	-	RESERVED	RESERVED	-	RESERVED		X
Bit 3	-	RESERVED	RESERVED	-	RESERVED		X
Bit 2	-	RESERVED	RESERVED	-	RESERVED		X
Bit 1	-	RESERVED	RESERVED	-	RESERVED		X
Bit 0	-	RESERVED	RESERVED	-	RESERVED		X

I²C Table: VCO Frequency Control Register

Byte 11	Pin #	Name	Control Function	Type	0	1	PWD
Bit 7	-	N Div8	N Divider Bit 8	RW	-	-	X
Bit 6	-	M Div6	The decimal representation of M Div (6:0) is equal to reference divider value. Default at power up = latch-in or Byte 0 Rom table.	RW	-	-	X
Bit 5	-	M Div5		RW	-	-	X
Bit 4	-	M Div4		RW	-	-	X
Bit 3	-	M Div3		RW	-	-	X
Bit 2	-	M Div2		RW	-	-	X
Bit 1	-	M Div1		RW	-	-	X
Bit 0	-	M Div0		RW	-	-	X



²C Table: VCO Frequency Control Register

Byte 12	Pin #	Name	Control Function	Type	0	1	PWD
Bit 7	-	N Div7	The decimal representation of N Div (8:0) is equal to VCO divider value. Default at power up = latch-in or Byte 0 Rom table.	RW	-	-	X
Bit 6	-	N Div6		RW	-	-	X
Bit 5	-	N Div5		RW	-	-	X
Bit 4	-	N Div4		RW	-	-	X
Bit 3	-	N Div3		RW	-	-	X
Bit 2	-	N Div2		RW	-	-	X
Bit 1	-	N Div1		RW	-	-	X
Bit 0	-	N Div0		RW	-	-	X

²C Table: Spread Spectrum Control Register

Byte 13	Pin #	Name	Control Function	Type	0	1	PWD
Bit 7	-	SSP7	These Spread Spectrum bits will program the spread percentage. It is recommended to use ICS Spread % table for spread programming.	RW	-	-	X
Bit 6	-	SSP6		RW	-	-	X
Bit 5	-	SSP5		RW	-	-	X
Bit 4	-	SSP4		RW	-	-	X
Bit 3	-	SSP3		RW	-	-	X
Bit 2	-	SSP2		RW	-	-	X
Bit 1	-	SSP1		RW	-	-	X
Bit 0	-	SSP0		RW	-	-	X

²C Table: Spread Spectrum Control Register

Byte 14	Pin #	Name	Control Function	Type	0	1	PWD
Bit 7	-	Reserved	Reserved	RW	-	-	0
Bit 6	-	Reserved	Reserved	RW	-	-	0
Bit 5	-	SSP13	It is recommended to use ICS Spread % table for spread programming.	RW	-	-	X
Bit 4	-	SSP12		RW	-	-	X
Bit 3	-	SSP11		RW	-	-	X
Bit 2	-	SSP10		RW	-	-	X
Bit 1	-	SSP9		RW	-	-	X
Bit 0	-	SSP8		RW	-	-	X

PD#, Power Down

PD# is an asynchronous active low input used to shut off all clocks cleanly prior to clock power. When PD# is asserted low all clocks will be driven low before turning off the VCO. In PD# de-assertion all clocks will start without glitches.

PWRDWN#	CPU	CPU #	SRC	SRC#	3V66	PCIF/PCI	USB/DOT	REF	Note
1	Normal	Normal	Normal	Normal	66MHz	33MHz	48MHz	14.318MHz	
0	Iref * 2 or Float	Float	Iref * 2 or Float	Float	Low	Low	Low	Low	

Notes:

1. Refer to tristate control of CPU and SRC clocks in section 7.7 for tristate timing and operation.
2. Refer to Control Registers in section 16 for CPU_Stop, SRC_Stop and PwrDwn SMBus tristate control addresses.

PD# Assertion

PD# should be sampled low by 2 consecutive CPU# rising edges before stopping clocks. All single ended clocks will be held low on their next high to low transition. All differential clocks will be held high on the next high to low transition of the complimentary clock. If the control register determining to drive mode is set to 'tri-state', the differential pair will be stopped in tri-state mode, undriven. When the drive mode but corresponding to the CPU or SRC clock of interest is set to '0' the true clock will be driven high at 2 x Iref and the complementary clock will be tristated. If the control register is programmed to '1' both clocks will be tristated.

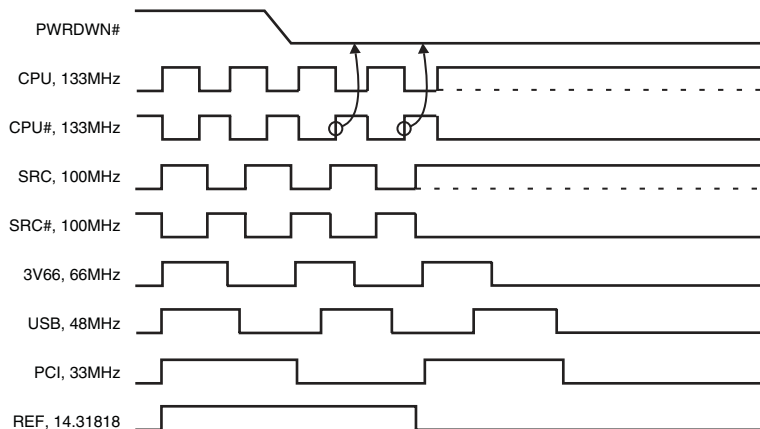

PD# De-assertion

The time from the de-assertion of PD# or until power supply ramps to get stable clocks will be less than 1.8ms. If the drive mode control bit for PD# tristate is programmed to '1' the stopped differential pair must first be driven high to a minimum of 200mV in less than 300µs of PD# deassertion.

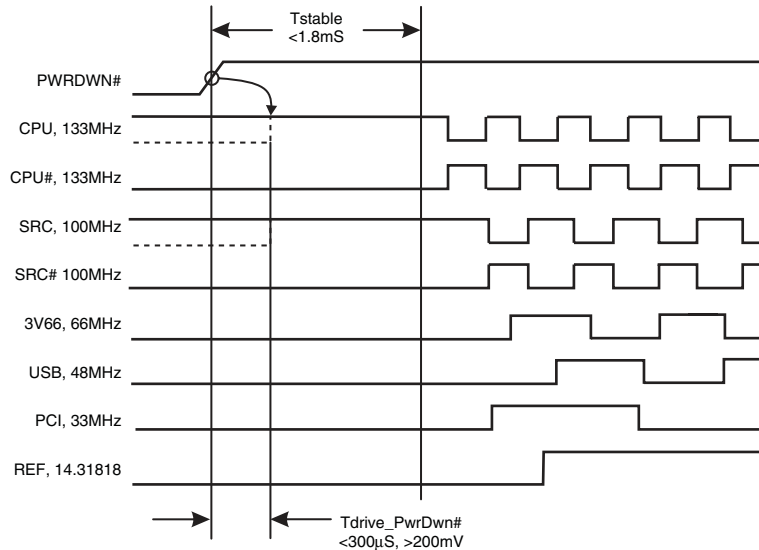

3V66_3/VCH Pin Functionality

The 3V66_4/VCH pin can be configured to be a 66.66MHz modulated output or a non-spread 48MHz output. The default is 3V66 clock. The switching is controlled by Byte 5 Bit 5. If it is set to '1' this pin will output the 48MHz VCH clock. The output will go low on the falling edge of 3V66 for a minimum of 7.49ns. Then the output will transition to 48MHz on the next rising edge of DOT_48 clock.

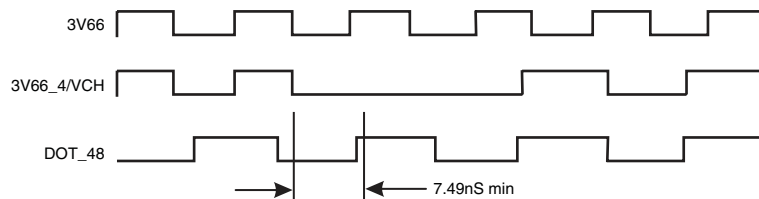

Shared Pin Operation - Input/Output Pins

The I/O pins designated by (input/output) serve as dual signal functions to the device. During initial power-up, they act as input pins. The logic level (voltage) that is present on these pins at this time is read and stored into a 5-bit internal data latch. At the end of Power-On reset, (see AC characteristics for timing values), the device changes the mode of operations for these pins to an output function. In this mode the pins produce the specified buffered clocks to external loads.

To program (load) the internal configuration register for these pins, a resistor is connected to either the VDD (logic 1) power supply or the GND (logic 0) voltage potential. A 10 Kilohm (10K) resistor is used to provide both the solid CMOS programming voltage needed during the power-up programming period and to provide an insignificant load on the output clock during the subsequent operating period.

Figure 1 shows a means of implementing this function when a switch or 2 pin header is used. With no jumper is installed the pin will be pulled high. With the jumper in place the pin will be pulled low. If programmability is not necessary, than only a single resistor is necessary. The programming resistors should be located close to the series termination resistor to minimize the current loop area. It is more important to locate the series termination resistor close to the driver than the programming resistor.

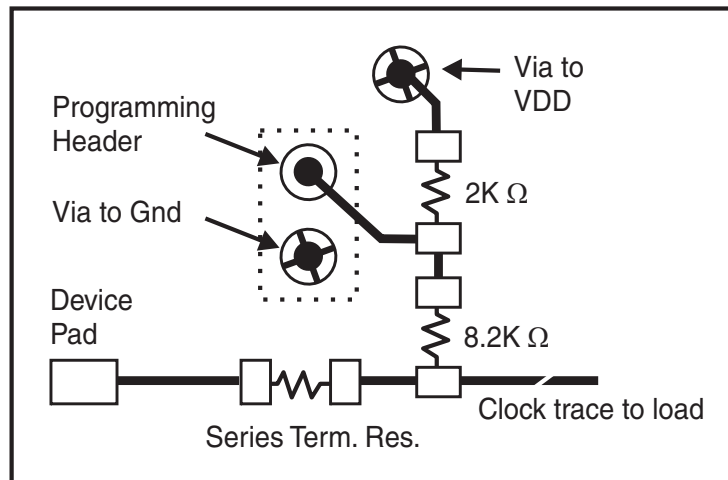
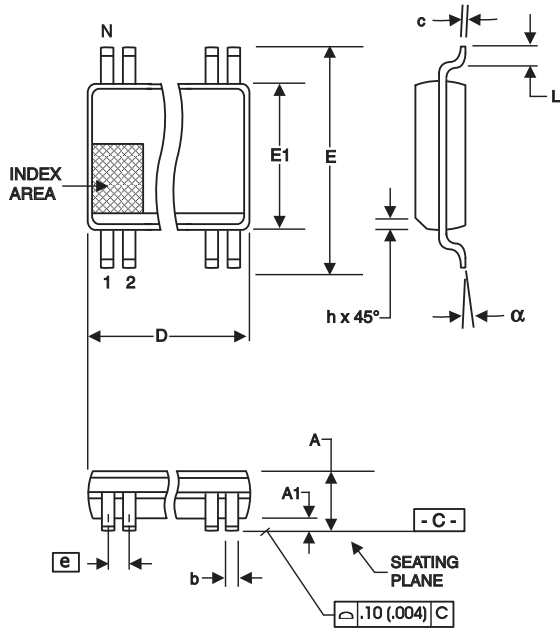

Fig. 1



SYMBOL	In Millimeters COMMON DIMENSIONS		In Inches COMMON DIMENSIONS	
	MIN	MAX	MIN	MAX
A	2.41	2.80	.095	.110
A1	0.20	0.40	.008	.016
b	0.20	0.34	.008	.0135
c	0.13	0.25	.005	.010
D	SEE VARIATIONS		SEE VARIATIONS	
E	10.03	10.68	.395	.420
E1	7.40	7.60	.291	.299
e	0.635 BASIC		0.025 BASIC	
h	0.38	0.64	.015	.025
L	0.50	1.02	.020	.040
N	SEE VARIATIONS		SEE VARIATIONS	
α	0°	8°	0°	8°

VARIATIONS

N	D mm.		D (inch)	
	MIN	MAX	MIN	MAX
48	15.75	16.00	.620	.630

Reference Doc.: JEDEC Publication 95, MO-118

10-0034

Ordering Information

ICS952606yFLFT

Example:

ICS XXXX y F LFT

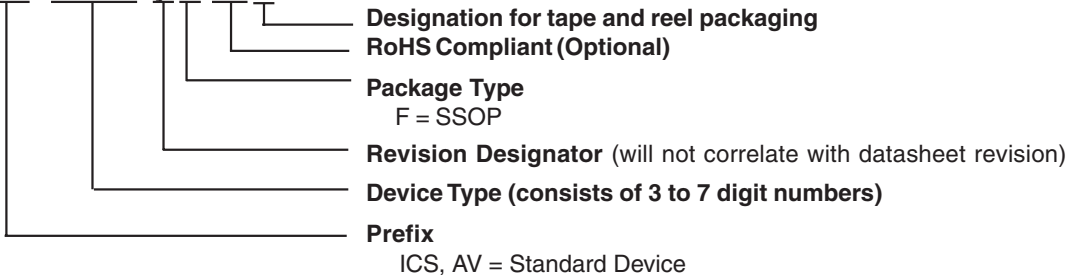



Revision History

Rev.	Issue Date	Description	Page #
E	6/9/2005	1. Updated pinout and pin description. 2. Updated LF Ordering Information to RoHS Compliant.	1-3, 19
F	6/10/2005	Updated Block Diagram	4