



Four Output Differential Buffer for PCI-Express

Recommended Application:

DB400 Intel Yellow Cover part with PCI-Express support.

Output Features:

- 4 - 0.7V current-mode differential output pairs
- Supports zero delay buffer mode and fanout mode
- Bandwidth programming available

Key Specifications:

- Outputs cycle-cycle jitter: < 50ps
- Outputs skew: < 50ps
- +/- 300ppm frequency accuracy on output clocks

Features/Benefits:

- Supports tight ppm accuracy clocks for Serial-ATA
- Spread spectrum modulation tolerant, 0 to -0.5% down spread and +/- 0.25% center spread
- Supports undriven differential output pair in PD# and SRC_STOP# for power management.

Pin Configuration

VDD	1	ICS9DB104	28	VDDA
SRC_IN	2		27	GNDA
SRC_IN#	3		26	IREF
GND	4		25	GND
VDD	5		24	VDD
DIF_1	6		23	DIF_6
DIF_1#	7		22	DIF_6#
OE_1	8		21	OE_6
DIF_2	9		20	DIF_5
DIF_2#	10		19	DIF_5#
VDD	11		18	VDD
BYPASS#/PLL	12		17	HIGH_BW#
SCLK	13		16	SRC_STOP#
SDATA	14		15	PD#

28-pin SSOP & TSSOP

Pin Description

PIN #	PIN NAME	PIN TYPE	DESCRIPTION
1	VDD	PWR	Power supply, nominal 3.3V
2	SRC_IN	IN	0.7 V Differential SRC TRUE input
3	SRC_IN#	IN	0.7 V Differential SRC COMPLEMENTARY input
4	GND	PWR	Ground pin.
5	VDD	PWR	Power supply, nominal 3.3V
6	DIF_1	OUT	0.7V differential true clock outputs
7	DIF_1#	OUT	0.7V differential complement clock outputs
8	OE_1	IN	Active high input for enabling outputs. 0 = tri-state outputs, 1= enable outputs
9	DIF_2	OUT	0.7V differential true clock outputs
10	DIF_2#	OUT	0.7V differential complement clock outputs
11	VDD	PWR	Power supply, nominal 3.3V
12	BYPASS#/PLL	IN	Input to select Bypass(fan-out) or PLL (ZDB) mode 0 = Bypass mode, 1= PLL mode
13	SCLK	IN	Clock pin of SMBus circuitry, 5V tolerant.
14	SDATA	I/O	Data pin for SMBus circuitry, 5V tolerant.
15	PD#	IN	Asynchronous active low input pin used to power down the device. The internal clocks are disabled and the VCO and the crystal are stopped.
16	SRC_STOP#	IN	Active low input to stop diff outputs.
17	HIGH_BW#	IN	3.3V input for selecting PLL Band Width 0 = High, 1= Low
18	VDD	PWR	Power supply, nominal 3.3V
19	DIF_5#	OUT	0.7V differential complement clock outputs
20	DIF_5	OUT	0.7V differential true clock outputs
21	OE_6	IN	Active high input for enabling outputs. 0 = tri-state outputs, 1= enable outputs
22	DIF_6#	OUT	0.7V differential complement clock outputs
23	DIF_6	OUT	0.7V differential true clock outputs
24	VDD	PWR	Power supply, nominal 3.3V
25	GND	PWR	Ground pin.
26	IREF	OUT	This pin establishes the reference current for the differential current-mode output pairs. This pin requires a fixed precision resistor tied to ground in order to establish the appropriate current. 475 ohms is the standard value.
27	GNDA	PWR	Ground pin for the PLL core.
28	VDDA	PWR	3.3V power for the PLL core.

General Description

ICS9DB104 follows the Intel DB400 Differential Buffer Specification. This buffer provides four SRC clocks for PCI-Express, next generation I/O devices. **ICS9DB104** is driven by a differential input pair from a CK409/CK410 main clock generator, such as the ICS952601 or ICS954101. **ICS9DB104** can run at speeds up to 200MHz. It provides outputs meeting tight cycle-to-cycle jitter (50ps) and output-to-output skew (50ps) requirements.

Block Diagram

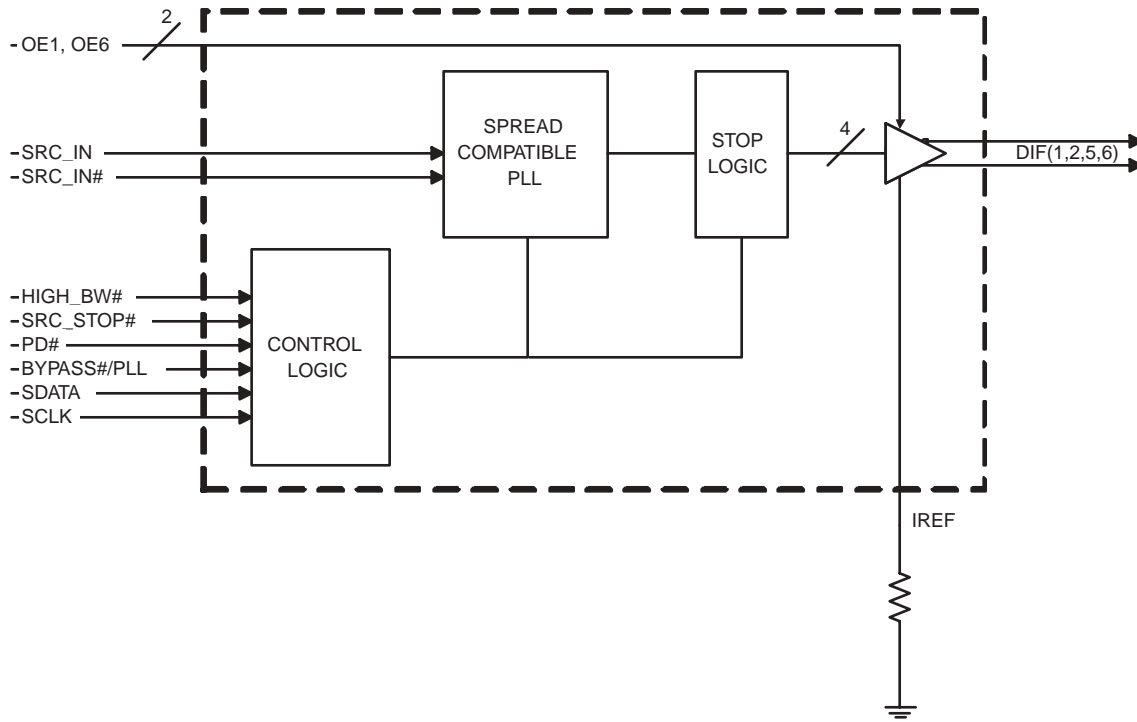

Power Groups

Pin Number		Description
VDD	GND	
1	4	SRC_IN/SRC_IN#
5,11,18,24	4,25	DIF Outputs
28	27	IREF
28	27	Analog VDD & GND for PLL core

Absolute Max

Symbol	Parameter	Min	Max	Units
VDD_A	3.3V Core Supply Voltage		4.6	V
VDD_In	3.3V Logic Supply Voltage		4.6	V
V _{IL}	Input Low Voltage	GND-0.5		V
V _{IH}	Input High Voltage		V _{DD} +0.5V	V
T _s	Storage Temperature	-65	150	°C
T _{ambient}	Ambient Operating Temp	0	70	°C
T _{case}	Case Temperature		115	°C
ESD prot	Input ESD protection human body model	2000		V

Electrical Characteristics - Input/Supply/Common Output Parameters

T_A = 0 - 70°C; Supply Voltage V_{DD} = 3.3 V +/-5%

PARAMETER	SYMBOL	CONDITIONS	MIN	TYP	MAX	UNITS	NOTES
Input High Voltage	V _{IH}	3.3 V +/-5%	2		V _{DD} + 0.3	V	
Input Low Voltage	V _{IL}	3.3 V +/-5%	GND - 0.3		0.8	V	
Input High Current	I _{IH}	V _{IN} = V _{DD}	-5		5	uA	
Input Low Current	I _{IL1}	V _{IN} = 0 V; Inputs with no pull-up resistors	-5			uA	
	I _{IL2}	V _{IN} = 0 V; Inputs with pull-up resistors	-200			uA	
Operating Supply Current	I _{DD3.3OP}	Full Active, C _L = Full load;			200	mA	
Powerdown Current	I _{DD3.3PD}	all diff pairs driven			40	mA	
		all differential pairs tri-stated			12	mA	
Input Frequency ³	F _i	V _{DD} = 3.3 V	80	100/133 166/200	220	MHz	3
Pin Inductance ¹	L _{pin}				7	nH	1
Input Capacitance ¹	C _{IN}	Logic Inputs	1.5		5	pF	1
	C _{OUT}	Output pin capacitance			6	pF	1
PLL Bandwidth	BW	PLL Bandwidth when PLL_BW=0		4		MHz	1
		PLL Bandwidth when PLL_BW=1		2		MHz	1
Clk Stabilization ^{1,2}	T _{STAB}	From V _{DD} Power-Up and after input clock stabilization or de-assertion of PD# to 1st clock			1	ms	1,2
Modulation Frequency		Triangular Modulation	30		33	kHz	1
Tdrive_SRC_STOP#		DIF output enable after SRC_Stop# de-assertion			10	ns	1,3
Tdrive_PD#		DIF output enable after PD# de-assertion			300	us	1,3
Tfall		Fall time of PD# and SRC_STOP#			5	ns	1
Trise		Rise time of PD# and SRC_STOP#			5	ns	2

¹Guaranteed by design and characterization, not 100% tested in production.

²See timing diagrams for timing requirements.

³Time from deassertion until outputs are >200 mV

Electrical Characteristics - DIF 0.7V Current Mode Differential Pair

$T_A = 0 - 70^\circ\text{C}$; $V_{DD} = 3.3\text{ V} \pm 5\%$; $C_L = 2\text{pF}$, $R_S = 33.2\Omega$, $R_P = 49.9\Omega$, $I_{REF} = 475\Omega$

PARAMETER	SYMBOL	CONDITIONS	MIN	TYP	MAX	UNITS	NOTES
Current Source Output Impedance	Z_o^1	$V_O = V_x$	3000			Ω	1
Voltage High	VHigh	Statistical measurement on single ended signal using oscilloscope math function.	660		850	mV	1,3
Voltage Low	VLow		-150		150		1,3
Max Voltage	Vovs	Measurement on single ended signal using absolute value.			1150	mV	1
Min Voltage	Vuds		-300				1
Crossing Voltage (abs)	Vcross(abs)		250		550	mV	1
Crossing Voltage (var)	d-Vcross	Variation of crossing over all edges			140	mV	1
Long Accuracy	ppm	see Tperiod min-max values			0	ppm	1,2
Average period	Tperiod	200MHz nominal	4.9985		5.0015	ns	2
		200MHz spread	4.9985		5.0266	ns	2
		166.66MHz nominal	5.9982		6.0018	ns	2
		166.66MHz spread	5.9982		6.0320	ns	2
		133.33MHz nominal	7.4978		7.5023	ns	2
		133.33MHz spread	7.4978		5.4000	ns	2
		100.00MHz nominal	9.9970		10.0030	ns	2
		100.00MHz spread	9.9970		10.0533	ns	2
Absolute min period	T_{absmin}	200MHz nominal	4.8735			ns	1,2
		166.66MHz nominal/spread	5.8732			ns	1,2
		133.33MHz nominal/spread	7.3728			ns	1,2
		100.00MHz nominal/spread	9.8720			ns	1,2
Rise Time	t_r	$V_{OL} = 0.175\text{V}$, $V_{OH} = 0.525\text{V}$	175		700	ps	1
Fall Time	t_f	$V_{OH} = 0.525\text{V}$, $V_{OL} = 0.175\text{V}$	175		700	ps	1
Rise Time Variation	d- t_r				125	ps	1
Fall Time Variation	d- t_f				125	ps	1
Duty Cycle	d_{r3}	Measurement from differential waveform	45		55	%	1
Skew	t_{sk3}	$V_T = 50\%$			50	ps	1
Jitter, Cycle to cycle	$t_{jyc-cyc}$	PLL mode, Measurement from differential waveform			50	ps	1
		BYPASS mode as additive jitter			50	ps	1

¹Guaranteed by design and characterization, not 100% tested in production.

²All Long Term Accuracy and Clock Period specifications are guaranteed with the assumption that the input clock complies with CK409/CK410 accuracy requirements

³ $I_{REF} = V_{DD}/(3 \times R_R)$. For $R_R = 475\Omega$ (1%), $I_{REF} = 2.32\text{mA}$. $I_{OH} = 6 \times I_{REF}$ and $V_{OH} = 0.7\text{V}$ @ $Z_O = 50\Omega$.

General SMBus serial interface information for the ICS9DB104

How to Write:

- Controller (host) sends a start bit.
- Controller (host) sends the write address $DC_{(H)}$
- ICS clock will **acknowledge**
- Controller (host) sends the beginning byte location = N
- ICS clock will **acknowledge**
- Controller (host) sends the data byte count = X
- ICS clock will **acknowledge**
- Controller (host) starts sending **Byte N through Byte N + X - 1**
(see Note 2)
- ICS clock will **acknowledge** each byte **one at a time**
- Controller (host) sends a Stop bit

Index Block Write Operation		
Controller (Host)		ICS (Slave/Receiver)
T	starT bit	
Slave Address $DC_{(H)}$		
WR	WRite	
		ACK
Beginning Byte = N		
		ACK
Data Byte Count = X		
		ACK
Beginning Byte N		X Byte
	○	
	○	
	○	
	○	
Byte N + X - 1		
		ACK
P	stoP bit	

How to Read:

- Controller (host) will send start bit.
- Controller (host) sends the write address $DC_{(H)}$
- ICS clock will **acknowledge**
- Controller (host) sends the beginning byte location = N
- ICS clock will **acknowledge**
- Controller (host) will send a separate start bit.
- Controller (host) sends the read address $DD_{(H)}$
- ICS clock will **acknowledge**
- ICS clock will send the data byte count = X
- ICS clock sends **Byte N + X - 1**
- ICS clock sends **Byte 0 through byte X (if $X_{(H)}$ was written to byte 8)**.
- Controller (host) will need to acknowledge each byte
- Controller (host) will send a not acknowledge bit
- Controller (host) will send a stop bit

Index Block Read Operation			
Controller (Host)		ICS (Slave/Receiver)	
T	starT bit		
Slave Address $DC_{(H)}$			
WR	WRite		
		ACK	
Beginning Byte = N			
		ACK	
RT	Repeat starT		
Slave Address $DD_{(H)}$			
RD	ReaD		
		ACK	
		Data Byte Count = X	
ACK			
ACK		X Byte	
			Beginning Byte N
			○
			○
			○
		○	
		Byte N + X - 1	
N	Not acknowledge		
P	stoP bit		

SMBus Table: Frequency Select Register, READ/WRITE ADDRESS (DC/DD)

Byte 0	Pin #	Name	Control Function	Type	0	1	PWD
Bit 7	-	PD# drive mode		RW	driven	Hi-Z	0
Bit 6	-	SRC_Stop# drive		RW	driven	Hi-Z	0
Bit 5	-	Reserved		RW	Reserved		X
Bit 4	-	Reserved		RW	Reserved		X
Bit 3	-	Reserved		RW	Reserved		X
Bit 2	-	PLL_BW# adjust		RW	High BW	Low BW	1
Bit 1	-	BYPASS#/PLL		RW	fan-out	ZDB	1
Bit 0	-	SRC_DIV#		RW	div /2	x1	1

SMBus Table: Output Control Register

Byte 1	Pin #	Name	Control Function	Type	0	1	PWD
Bit 7	-	Reserved		RW	User should write '0' to minimize power		1
Bit 6	23,22	DIF_6	Output Control	RW	Disable	Enable	1
Bit 5	20,19	DIF_5	Output Control	RW	Disable	Enable	1
Bit 4	-	Reserved		RW	User should write '0' to minimize power		1
Bit 3	-	Reserved		RW	User should write '0' to minimize power		1
Bit 2	9,10	DIF_2	Output Control	RW	Disable	Enable	1
Bit 1	6,7	DIF_1	Output Control	RW	Disable	Enable	1
Bit 0	-	Reserved		RW	User should write '0' to minimize power		1

SMBus Table: Output Control Register

Byte 2	Pin #	Name	Control Function	Type	0	1	PWD
Bit 7	-	Reserved		RW	Reserved		0
Bit 6	23,22	DIF_6	Output Control	RW	Free-run	Stoppable	0
Bit 5	20,19	DIF_5	Output Control	RW	Free-run	Stoppable	0
Bit 4	-	Reserved		RW	Reserved		0
Bit 3	-	Reserved		RW	Reserved		0
Bit 2	9,10	DIF_2	Output Control	RW	Free-run	Stoppable	0
Bit 1	6,7	DIF_1	Output Control	RW	Free-run	Stoppable	0
Bit 0	-	Reserved		RW	Reserved		0

SMBus Table: Output Control Register

Byte 3		Pin #	Name	Control Function	Type	0	1	PWD
Bit 7				Reserved	RW	Reserved		X
Bit 6				Reserved	RW	Reserved		X
Bit 5				Reserved	RW	Reserved		X
Bit 4				Reserved	RW	Reserved		X
Bit 3				Reserved	RW	Reserved		X
Bit 2				Reserved	RW	Reserved		X
Bit 1				Reserved	RW	Reserved		X
Bit 0				Reserved	RW	Reserved		X

SMBus Table: Vendor & Revision ID Register

Byte 4		Pin #	Name	Control Function	Type	0	1	PWD
Bit 7	-		RID3	REVISION ID	R	-	-	X
Bit 6	-		RID2		R	-	-	X
Bit 5	-		RID1		R	-	-	X
Bit 4	-		RID0		R	-	-	X
Bit 3	-		VID3	VENDOR ID	R	-	-	0
Bit 2	-		VID2		R	-	-	0
Bit 1	-		VID1		R	-	-	0
Bit 0	-		VID0		R	-	-	1

SMBus Table: DEVICE ID

Byte 5		Pin #	Name	Control Function	Type	0	1	PWD
Bit 7	-		Device ID 7 (MSB)		RW	Reserved		0
Bit 6	-		Device ID 6		RW	Reserved		0
Bit 5	-		Device ID 5		RW	Reserved		0
Bit 4	-		Device ID 4		RW	Reserved		0
Bit 3	-		Device ID 3		RW	Reserved		1
Bit 2	-		Device ID 2		RW	Reserved		0
Bit 1	-		Device ID 1		RW	Reserved		0
Bit 0	-		Device ID 0		RW	Reserved		0

SMBus Table: Byte Count Register

Byte 6		Pin #	Name	Control Function	Type	0	1	PWD
Bit 7	-		BC7	Writing to this register configures how many bytes will be read back.	RW	-	-	0
Bit 6	-		BC6		RW	-	-	0
Bit 5	-		BC5		RW	-	-	0
Bit 4	-		BC4		RW	-	-	0
Bit 3	-		BC3		RW	-	-	0
Bit 2	-		BC2		RW	-	-	1
Bit 1	-		BC1		RW	-	-	0
Bit 0	-		BC0		RW	-	-	1

PD#

The PD# pin cleanly shuts off all clocks and places the device into a power saving mode. PD# must be asserted before shutting off the input clock or power to insure an orderly shutdown. PD is asynchronous active-low input for both powering down the device and powering up the device. When PD# is asserted, all clocks will be driven high, or tri-stated (depending on the PD# drive mode and Output control bits) before the PLL is shut down.

PD# Assertion

When PD# is sampled low by two consecutive rising edges of DIF#, all DIF outputs must be held High, or tri-stated (depending on the PD# drive mode and Output control bits) on the next High-Low transition of the DIF# outputs. When the PD# drive mode bit is set to '0', all clock outputs will be held with DIF driven High with $2 \times I_{REF}$ and DIF# tri-stated. If the PD# drive mode bit is set to '1', both DIF and DIF# are tri-stated.

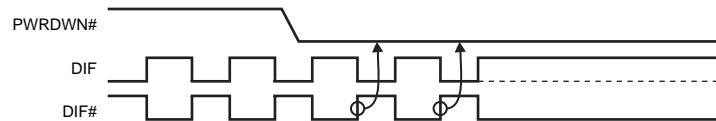

PD# De-assertion

Power-up latency is less than 1 ms. This is the time from de-assertion of the PD# pin, or VDD reaching 3.3V, or the time from valid SRC_IN clocks until the time that stable clocks are output from the device (PLL Locked). If the PD# drive mode bit is set to '1', all the DIF outputs must driven to a voltage of >200 mV within 300 ms of PD# de-assertion.

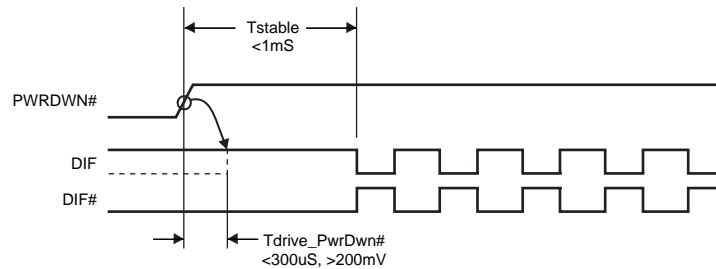

SRC_STOP#

The SRC_STOP# signal is an active-low asynchronous input that cleanly stops and starts the DIF outputs. A valid clock must be present on SRC_IN for this input to work properly. The SRC_STOP# signal is de-bounced and must remain stable for two consecutive rising edges of DIF# to be recognized as a valid assertion or de-assertion.

SRC_STOP# - Assertion (transition from '1' to '0')

Asserting SRC_STOP# causes all DIF outputs to stop after their next transition (if the control register settings allow the output to stop). When the SRC_STOP# drive bit is '0', the final state of all stopped DIF outputs is DIF = High and DIF# = Low. There is no change in output drive current. DIF is driven with 6xI_{REF}. DIF# is not driven, but pulled low by the termination. When the SRC_STOP# drive bit is '1', the final state of all DIF output pins is Low. Both DIF and DIF# are not driven.

SRC_STOP# - De-assertion (transition from '0' to '1')

All stopped differential outputs resume normal operation in a glitch-free manner. The de-assertion latency to active outputs is 2-6 DIF clock periods, with all DIF outputs resuming simultaneously. If the SRC_STOP# drive control bit is '1' (tri-state), all stopped DIF outputs must be driven High (>200 mV) within 10 ns of de-assertion.

SRC_STOP_1 (SRC_Stop = Driven, PD = Driven)

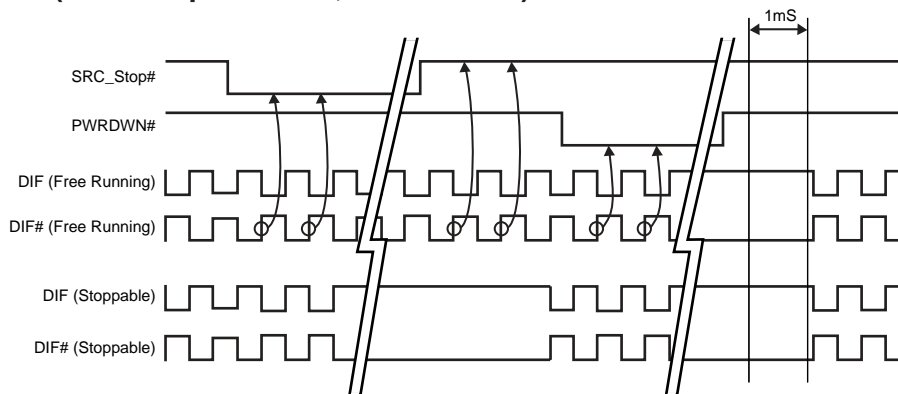

SRC_STOP_2 (SRC_Stop = Tristate, PD = Driven)

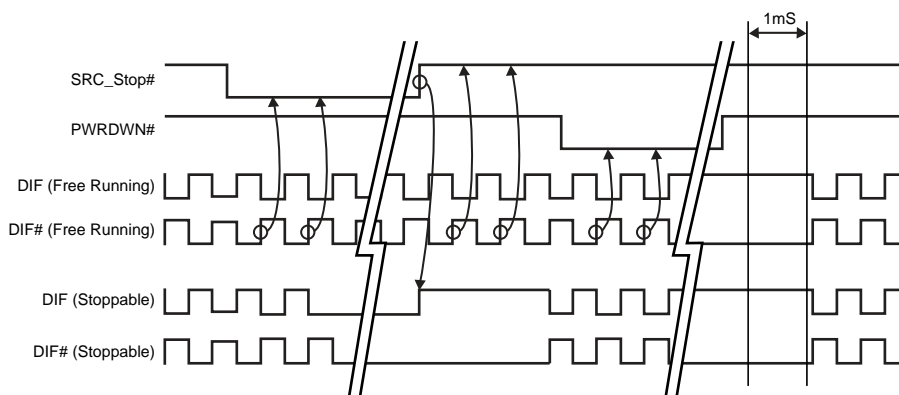

SRC_STOP_3 (SRC_Stop = Driven, PD = Tristate)

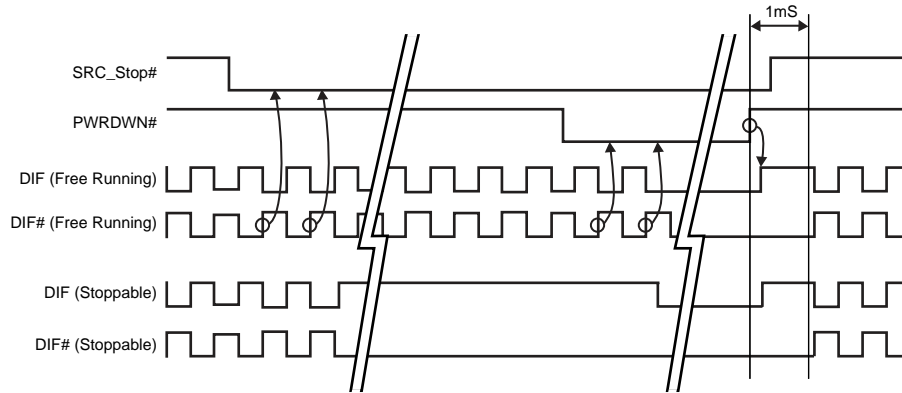

SRC_STOP_4 (SRC_Stop = Tristate, PD = Tristate)

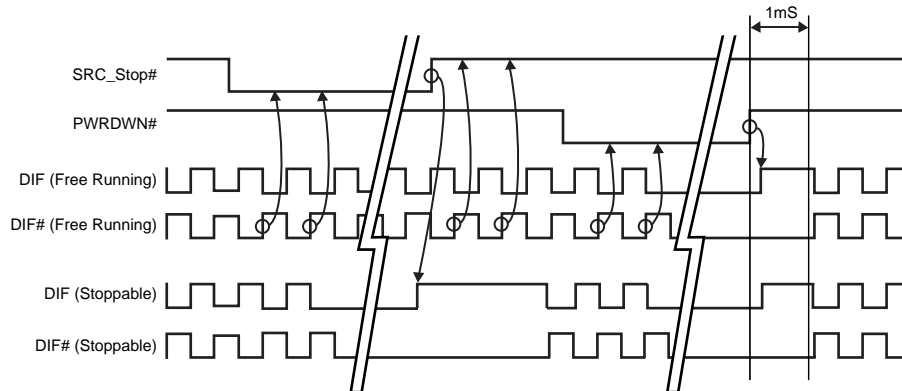

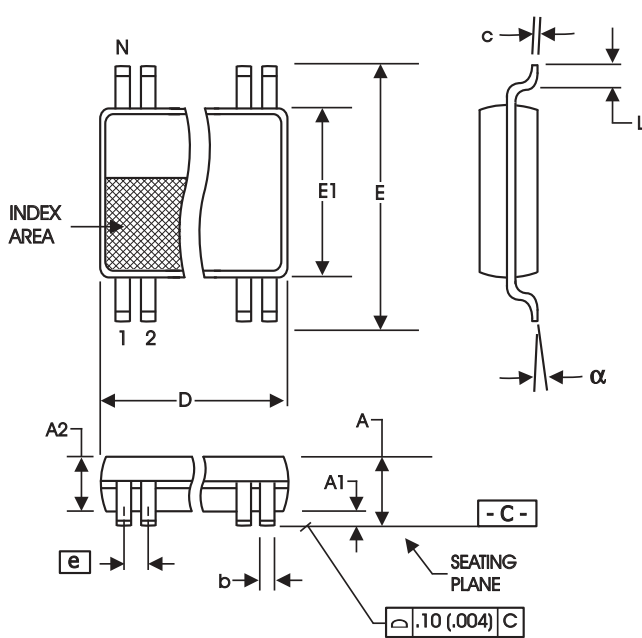

209 mil SSOP

SYMBOL	In Millimeters		In Inches	
	MIN	MAX	MIN	MAX
A	--	2.00	--	.079
A1	0.05	--	.002	--
A2	1.65	1.85	.065	.073
b	0.22	0.38	.009	.015
c	0.09	0.25	.0035	.010
D	SEE VARIATIONS		SEE VARIATIONS	
E	7.40	8.20	.291	.323
E1	5.00	5.60	.197	.220
e	0.65 BASIC		0.0256 BASIC	
L	0.55	0.95	.022	.037
N	SEE VARIATIONS		SEE VARIATIONS	
α	0°	8°	0°	8°

VARIATIONS

N	D mm.		D (inch)	
	MIN	MAX	MIN	MAX
28	9.90	10.50	.390	.413

Reference Doc.: JEDEC Publication 95, MO-150

10-0033

Ordering Information

ICS9DB104yFLFT

Example:

ICS XXXX y F LFT

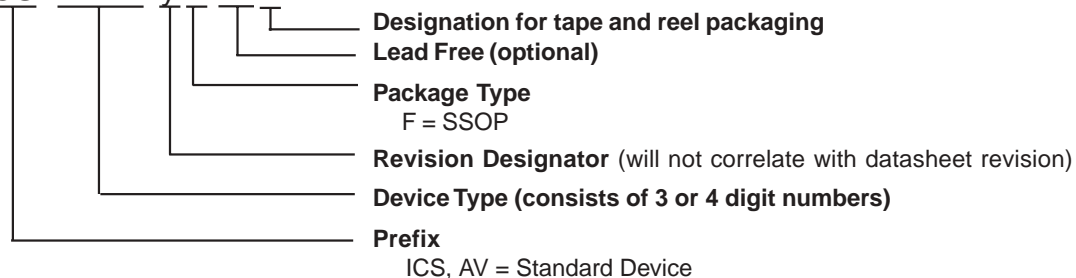

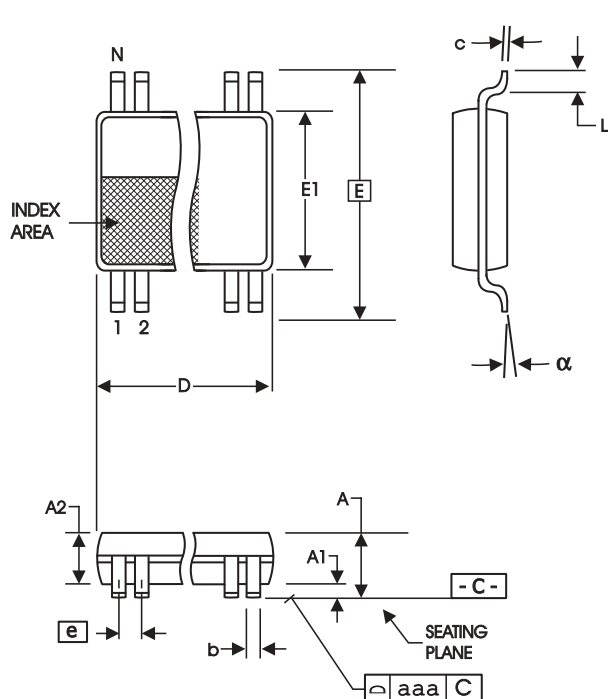

4.40 mm. Body, 0.65 mm. Pitch TSSOP
(173 mil) (25.6 mil)

SYMBOL	In Millimeters COMMON DIMENSIONS		In Inches COMMON DIMENSIONS	
	MIN	MAX	MIN	MAX
A	--	1.20	--	.047
A1	0.05	0.15	.002	.006
A2	0.80	1.05	.032	.041
b	0.19	0.30	.007	.012
c	0.09	0.20	.0035	.008
D	SEE VARIATIONS		SEE VARIATIONS	
E	6.40 BASIC		0.252 BASIC	
E1	4.30	4.50	.169	.177
e	0.65 BASIC		0.0256 BASIC	
L	0.45	0.75	.018	.030
N	SEE VARIATIONS		SEE VARIATIONS	
a	0°	8°	0°	8°
aaa	--	0.10	--	.004

VARIATIONS

N	D mm.		D (inch)	
	MIN	MAX	MIN	MAX
28	9.60	9.80	.378	.386

Reference Doc.: JEDEC Publication 95, MO-153

10-0035

Ordering Information

ICS9DB104yGLFT

Example:

ICS XXXX y G LFT

