



FM336Plus

V.34/Group 3 High Performance Fax Modem Family

The Conexant™ FM336Plus High Performance Fax Modem family offers ITU-T V.34 half-duplex mode operation that supports synchronous Group 3 facsimile send and receive speeds up to 33600 bits per second (bps). The FM336Plus-D and FM336Plus-D90 support ITU-T V.34 duplex data and synchronous/asynchronous modes with rates up to 33600 bps. The FM336Plus-D90 also supports ITU-T V.90 PCM mode, which can receive data at speeds up to 56 kbps.

The device has low voltage operation and is housed in a 100-pin Plastic Quad Flat Package (PQFP). The modem's small size and low power consumption allow the design of compact system enclosures for use in industrial, office, and home environments. Table 1 lists the FM336Plus Modem Family models and features.

Utilizing V.34 and V.90 techniques to optimize modem configuration for line conditions, the modem connects at the optimal selected data rate that the channel can support from 2400 bps up to 56000 bps. The modem can operate over the Public Switched Telephone Network (PSTN) through a line terminator provided by a Data Access Arrangement (DAA).

The FM336Plus is backward pin compatible with the previous Conexant FM336 fax modem, and supports all features of the FM336 family. The FM336Plus also has numerous feature and performance enhancements. For more information on the enhancements, refer to the *FM336Plus High Performance Fax Modem Designer's Guide* (document 101360).

Features (Entire FM336Plus Family)

- 2-wire half-duplex fax modem modes with send and receive data rates up to 33600 bps
 - V.34 half-duplex, V.17, V.33, V.29, V.27 ter, and V.21 channel 2
 - Short train option in V.17 and V.27 ter
- 2-wire duplex data modem modes
 - V.21, V.23 (75 bps TX/1200 bps RX or 1200 bps TX/75 bps RX)
- PSTN session starting
 - V.8 and V.8bis signaling
- HDLC support at all speeds
 - Flag generation, 0-bit stuffing, ITU CRC-16 or CRC-32 calculation and generation
 - Flag detection, 0 bit deletion, ITU CRC-16 or CRC-32 check sum error detection
 - FSK flag pattern detection during high-speed receiving
- Tone modes and features
 - Programmable single or dual tone generation
 - DTMF receiver
 - Tone detection with three programmable tone detectors
- Serial synchronous data
- Parallel synchronous data
- Automatic Rate Adaptation (ARA) in V.34 half-duplex
- Auto-dial and auto-answer control
- TTL and CMOS compatible DTE interface
 - ITU-T V.24 (EIA/TIA-232-E) (data/control)
 - Microprocessor bus (data/configuration/control)
- Receive dynamic range:
 - 0 dBm to –43 dBm for V.17, V.33, V.29, V.27 ter and V.21
 - –9 dBm to –43 dBm for V.34 half-duplex
- Quick Start for V.34 half-duplex (Conexant Proprietary)
- Caller ID Demodulation
- Call Waiting Detector
- ADPCM Voice Mode

Table 1. FM336Plus Modem Family Models and Features

Modem Model	Part Number	V.34 Fax	Data Mode (-D)	V.90 PCM Mode (-D90)	Clock Input	
					Oscillator Clock	Crystal Clock
FM336Plus	CX06832-11	Yes	No	No	Yes	No
FM336Plus	CX06832-12	Yes	No	No	No	Yes
FM336Plus-D	CX06832-13	Yes	Yes	No	Yes	No
FM336Plus-D	CX06832-14	Yes	Yes	No	No	Yes
FM336Plus-D90	CX06832-15	Yes	Yes	Yes	Yes	No
FM336Plus-D90	CX06832-16	Yes	Yes	Yes	No	Yes



Features (Entire FM336Plus Family–Continued)

- Programmable RLSA turn-on and turn-off thresholds
- Programmable transmit level: 0 to –15 dBm
- Adjustable speaker output to monitor received signal
- DMA support for interrupt lines
- Two 16-byte FIFO data buffers for burst data transfer with extension up to 255 bytes
- Diagnostic capability
- V.21 Channel 1 Flag detect
- V.21 Channel 2 Flag detect
- +3.3 V operation with +5 V tolerant inputs
- +5 V analog signal interface
- 100-pin PQFP package
- Typical power consumption
 - Sleep mode: 20 mW
 - Normal mode: 250 mW

Distinguishing Features (-D / -D90)

- 2-wire duplex data modem modes with send and receive rates up to 33600 bps
 - V.34 (33.6 kbps), V.32 bis, V.32, V.22 bis, and V.22
 - Bell 212A and 103
- Serial asynchronous data
- Parallel asynchronous data
- In-band secondary channel (V.34 and V.32 bis)
- Automatic Rate Adaptation (ARA) in V.34 duplex and V.32 bis
- Automatic Mode Selection (AMS)
- Digital near-end and far-end echo cancellation
- Bulk delay for satellite transmission
- Receive dynamic range:
 - –9 dBm to –43 dBm for V.34, V.32 bis, V.32, V.22 bis, V.22, and V.23
- 511 pattern generation/detection
- V.13 signaling
- Diagnostic capability
 - V.54 inter-DCE signaling
 - V.54 local analog and remote digital loopback

Distinguishing Features (-D90 only)

- 2-wire duplex data modem modes with receive data rates up to 56 kbps and send data rates as specified in the V.34 specification
 - V.90 PCM mode

Copyright © 2000, Conexant Systems, Inc., All Rights Reserved.

Information in this document is provided in connection with Conexant Systems, Inc. ("Conexant") products. These materials are provided by Conexant as a service to its customers and may be used for informational purposes only. Conexant assumes no responsibility for errors or omissions in these materials. Conexant may make changes to specifications and product descriptions at any time, without notice. Conexant makes no commitment to update the information contained herein. Conexant shall have no responsibility whatsoever for conflicts or incompatibilities arising from future changes to its specifications and product descriptions.

No license, express or implied, by estoppel or otherwise, to any intellectual property rights is granted by this document. Except as provided in Conexant's Terms and Conditions of Sale for such products, Conexant assumes no liability whatsoever.

THESE MATERIALS ARE PROVIDED "AS IS" WITHOUT WARRANTY OF ANY KIND, EITHER EXPRESS OR IMPLIED, RELATING TO SALE AND/OR USE OF CONEXANT PRODUCTS INCLUDING LIABILITY OR WARRANTIES RELATING TO FITNESS FOR A PARTICULAR PURPOSE, MERCHANTABILITY, OR INFRINGEMENT OF ANY PATENT, COPYRIGHT OR OTHER INTELLECTUAL PROPERTY RIGHT. Conexant further does not warrant the accuracy or completeness of the information, text, graphics or other items contained within these materials. Conexant shall not be liable for any special, indirect, incidental, or consequential damages, including without limitation, lost revenues or lost profits, which may result from the use of these materials.

Conexant products are not intended for use in medical, life saving or life sustaining applications. Conexant customers using or selling Conexant products for use in such applications do so at their own risk and agree to fully indemnify Conexant for any damages resulting from such improper use or sale.

The following are trademarks of Conexant Systems, Inc.: Conexant, the Conexant C symbol, and "What's Next in Communications Technologies." Product names or services listed in this publication are for identification purposes only, and may be trademarks of third parties. Third-party brands and names are the property of their respective owners.

Reader Response: Conexant strives to produce quality documentation and welcomes your feedback. Please send comments and suggestions to conexant.tech.pubs@conexant.com. For technical questions, contact your local Conexant sales office or field applications engineer.

GROUP3 FACSIMILE MODEM (ENTIRE FM336PLUS FAMILY)

The modem satisfies the requirements specified in ITU-T recommendations V.34 half-duplex, V.17, V.33, V.29, V.27 ter, V.21, and meets the binary signaling requirements of V.8 and T.30 with Annex F.

Internal HDLC support eliminates the need for an external serial input/output (SIO) device in the DTE for products incorporating error detection and T.30 protocol. The modem can perform HDLC framing per T.30 at all data speeds. CRC generation/checking along with zero insertion/deletion enhances SDLC/HDLC frame operations. Two FSK (V.21 Ch. 1 and V.21 Ch. 2) flag pattern detectors facilitate FSK detection during high-speed reception. The modem features a programmable DTMF transmitter/receiver and three programmable tone detectors.

DUPLEX DATA MODE (-D / -D90)

The duplex data mode supports Internet facsimile applications. The modem can connect at the highest data rate up to 33600 bps with auto fall back to V.32 bis. The FM336Plus-D and FM336Plus-D90 modems satisfy the requirements specified in ITU-T recommendations V.34, V.32 bis, V.32, V.22 bis, V.22, V.23, V.21, Bell 212A, and Bell 103.

ITU-T V.90 PCM MODE (-D90)

The ITU-T V.90 PCM mode can receive data at speeds up to 56 kbps from a digitally connected V.90 central site modem. The FM336Plus-D90 takes advantage of the PSTN which is primarily digital to the central office local loop (except for the client modem) and is ideal for applications such as remote access to an Internet Service Provider (ISP), online service, or corporate intranet. The modem can send upstream data at speeds up to the V.34 rate.

TECHNICAL SPECIFICATIONS

The FM336Plus modem provides the processing core for a complete facsimile modem design.

Configurations and Rates

The selectable modem configurations, signaling rates, and data rates are listed in Table 2.

Automatic Mode Selection (-D / -D90)

When Automatic Mode Selection (AMS) is enabled, the modem configures itself to the highest compatible data rate supported by the remote modem. Automode operation is supported in V.90 (-D90 only), V.34, V.32 bis, V.32, V.22 bis, V.22, V.21, V.23, Bell 212A, and Bell 103 modes.

Automatic Rate Adaptation

In V.34 duplex, V.34 half-duplex, and V.32 bis modes, Automatic Rate Adaptation (ARA) can be enabled to select the optimal highest acceptable data rate based on the Eye Quality Monitor (EQM). This selection occurs during startup.

Two ARA modes are available. ARA in ROM is an adaptive selection made by the modem based upon a fixed ROM table. ARA in RAM is based on the host programmable RAM table and can be changed by the user.

Data Encoding

The data encoding conforms to ITU-T recommendations V.90 (-D90 only), V.34, V.32 bis, V.32, V.17, V.33, V.29, V.27 ter, V.22 bis, V.22, V.23, or V.21, and is compatible with Bell 208, 212A, or 103, depending on the configuration.

Tone Generation

The modem can generate single or dual voice-band tones from 0 Hz to 3600 Hz with a resolution of 0.15 Hz and an accuracy of $\pm 0.01\%$. Tones over 3000 Hz are attenuated. DTMF tone generation allows the modem to operate as a programmable DTMF dialer.

Supervisory Tone Detection

Three parallel tone detectors (A, B, and C) are provided for supervisory tone detection. The signal path to these detectors is separate from the main received signal path.

Each tone detector consists of two cascaded second order IIR biquad filters. The coefficients are host programmable. Each fourth order filter is followed by a level detector which has host programmable turn-on and turn-off thresholds allowing hysteresis. A pre-filter and squarer precede tone detector C. This circuit is useful for detecting a tone with a frequency equal to the difference between two tones that may be simultaneously present on the line. The SQDIS bit may disable the squarer causing tone detector C to be an eight-order filter. The tone detectors are disabled in data mode.

The tone detection sample rate is 9600 Hz in V.8 and V.34 modes and is 7200 Hz in non-V.34 modes. The default call progress filter coefficients are based on a 7200 Hz sampling rate and apply to non-V.34 modes only. The maximum detection bandwidth is equal to one-half the sample rate.

Auto-Dialing and Auto-Answering Control

Features are provided to allow the host to perform auto-dialing and auto-answering. These functions include DTMF or pulse dialing, ring detection, and a comprehensive supervisory tone detection scheme. The major control parameters are host programmable.

Transmitted Data Spectrum

The transmitter spectrum is shaped by raised cosine filter functions, either the square root of 12.5% (V.34, V.32 bis, V.32), 20% (V.17, V.33, and V.29), 50% (V.27 ter, Bell 208), or 75% (V.22 bis, Bell 212A).

Transmit Level

The transmitter output level is selectable from 0 dBm to -15 dBm in 1 dB steps and is accurate to ± 0.5 dB when used with an external hybrid. The output level can also be tuned by changing a gain constant in the modem DSP RAM. The maximum V.34 transmit level for acceptable receive performance should not exceed -9 dBm.

Answer Tone (-D / -D90)

When the NV25 bit is a zero, the modem generates a 2100 Hz answer tone at the beginning of the answer handshake for 5.0 seconds (V.8) or 3.6 seconds (V.32 bis, V.32, V.22 bis, V.22, V.23, and V.21). The answer tone has 180° phase reversals every 0.45 seconds to disable network echo cancellers (V.8, V.32 bis, and V.32).

Receive Level

The modem satisfies performance requirements for received line signal levels from 0 dBm to -43 dBm measured at the receiver analog (TIP and RING) input in V.17, V.33, V.29, V.27 ter, and DTMF modes. In V.90, V.34, V.32 bis, V.32, V.22 bis, V.22, and V.23 modes, the receive level range is from -9 dBm (-15 dBm at RIN) to -43 dB. (RIN is 6 dB lower than TIP and RING.)

Carrier Recovery

The carrier recovery circuit can track a ± 7 Hz frequency offset in the received carrier.

Echo Canceller (-D / -D90)

A data echo canceller with near-end and far-end echo cancellation is included for 2-wire duplex V.90/V.34/V.32 bis/V.32 operation. The combined echo span of near and far cancellers can be up to 40 ms. The proportion allotted to each end is automatically determined by the modem. The delay between near-end and far-end echoes can be up to 1.2 seconds.

Table 2. Configurations, Signaling Rates, and Data Rates

Configuration	Modulation	Carrier Frequency (Hz) ±0.01%	Data Rate (bps) ±0.01%	Symbol Rate (Symbols/Sec)	Bits/Symbol Data	Bits/Symbol TCM	Constellation Points
V.90 PCM	PCM	—	56000 R/V.34 rates T (Note 4)	8000	Dynamic	—	—
V.34 33600 TCM**	TCM	Note 2	33600	3429 only	Note 2	Note 2	Note 2
V.34 31200 TCM**	TCM	Note 2	31200	3200 min	Note 2	Note 2	Note 2
V.34 28800 TCM**	TCM	Note 2	28800	3000 min	Note 2	Note 2	Note 2
V.34 26400 TCM**	TCM	Note 2	26400	2800 min	Note 2	Note 2	Note 2
V.34 24000 TCM**	TCM	Note 2	24000	2800 min	Note 2	Note 2	Note 2
V.34 21600 TCM**	TCM	Note 2	21600	2400 min	Note 2	Note 2	Note 2
V.34 19200 TCM**	TCM	Note 2	19200	Note 2	Note 2	Note 2	Note 2
V.34 16800 TCM**	TCM	Note 2	16800	Note 2	Note 2	Note 2	Note 2
V.34 14400 TCM**	TCM	Note 2	14400	Note 2	Note 2	Note 2	Note 2
V.34 12000 TCM**	TCM	Note 2	12000	Note 2	Note 2	Note 2	Note 2
V.34 9600 TCM**	TCM	Note 2	9600	Note 2	Note 2	Note 2	Note 2
V.34 7200 TCM**	TCM	Note 2	7200	Note 2	Note 2	Note 2	Note 2
V.34 4800 TCM**	TCM	Note 2	4800	Note 2	Note 2	Note 2	Note 2
V.34 2400 TCM**	TCM	Note 2	2400	2400 only	Note 2	Note 2	Note 2
V.32 bis 14400 TCM	TCM	1800	14400	2400	6	1	128
V.32 bis 12000 TCM	TCM	1800	12000	2400	5	1	64
V.32 bis 9600 TCM	TCM	1800	9600	2400	4	1	32
V.32 bis 7200 TCM	TCM	1800	7200	2400	3	1	16
V.32 bis 4800	QAM	1800	4800	2400	2	0	4
V.32 9600 TCM	TCM	1800	9600	2400	4	1	32
V.32 9600	QAM	1800	9600	2400	4	0	16
V.32 4800	QAM	1800	4800	2400	2	0	4
V.22bis 2400	QAM	1200/2400	2400	600	4	0	16
V.22bis 1200	DPSK	1200/2400	1200	600	2	0	4
V.22 1200	DPSK	1200/2400	1200	600	2	0	4
V.22 600	DPSK	1200/2400	600	600	1	0	4
V.23 1200/75	FSK	1700/420	1200/75	1200	1	0	—
V.21	FSK	1080/1750	Up to 300	300	1	0	—
Bell 208 4800	DPSK	1800	4800	1600	3	0	8
Bell 212A	DPSK	1200/2400	1200	600	2	0	4
Bell 103	FSK	1170/2125	Up to 300	300	1	0	—
V.17 14400 TCM/V.33	TCM	1800	14400	2400	6	1	128
V.17 12000 TCM/V.33	TCM	1800	12000	2400	5	1	64
V.17 9600 TCM	TCM	1800	9600	2400	4	1	32
V.17 7200 TCM	TCM	1800	7200	2400	3	1	16
V.29 9600	QAM	1700	9600	2400	4	0	16
V.29 7200	QAM	1700	7200	2400	3	0	8
V.29 4800	QAM	1700	4800	2400	2	0	4
V.27 ter 4800	DPSK	1800	4800	1600	3	0	8
V.27 ter 2400	DPSK	1800	2400	1200	2	0	4
V.21 Channel 2	FSK	1750	300	300	1	0	—

Notes:

1. Modulation legend:

TCM: Trellis-Coded Modulation
 QAM: Quadrature Amplitude Modulation
 PCM: Pulse Coded Modulation
 FSK: Frequency Shift Keying
 DPSK: Differential Phase Shift Keying

2. Adaptive; established during handshake:

Symbol Rate (Baud)	V.34 Low Carrier Frequency (Hz)	V.34 High Carrier Frequency (Hz)
2400	1600	1800
2800	1680	1867
3000	1800	2000
3200	1829	1920
3429	1959	1959

3. ** For both duplex and half-duplex modes.

4. Maximum data rate.

Data Formats

Serial Synchronous Data

- Data rate: 300–56000 bps (-D90) or 300–33600 bps $\pm 0.01\%$
- Selectable clock: Internal, external, or slave

Serial Asynchronous Data (-D / -D90)

- Data rate: 300–56000 bps (-D90) or 300–33600 bps $+1\%/-2.5\%$ or $+2.3\%/-2.5\%$; up to 300 bps (V.21 and Bell 103); 1200/75 bps (V.23)
- Data bits per character: 7, 8, 9, 10, or 11

Parallel Synchronous Data

- Normal sync: 8-bit data for transmit and receive
- Data rate: 300–56000 bps (-D90) or 300–33600 bps $\pm 0.01\%$
- SDLC/HDLC support:
 - Transmitter: Flag generation, 0-bit stuffing, CRC-16 or CRC-32 generation
 - Receiver: Flag detection, 0-bit deletion, CRC-16 or CRC-32 checking

Parallel Asynchronous Data (-D / -D90)

- Data rate: 300–56000 bps (-D90) or 300–33600 bps $+1\%/-2.5\%$ or $+2.3\%/-2.5\%$; 1200, 300, or 75 bps (FSK)
- Data bits per character: 5, 6, 7, or 8
- Parity generation/checking: Odd, Even, or 9th data bit

Async/Sync and Sync/Async Conversion (-D / -D90)

An asynchronous-to-synchronous converter is provided in the transmitter and a synchronous-to-asynchronous converter is provided in the receiver. The converters operate in both serial and parallel modes. The asynchronous character format is 1 start bit, 5 to 8 data bits, an optional parity bit, and 1 or 2 stop bits. Valid character size, including all bits, is 7, 8, 9, 10, or 11 bits per character. Two ranges of signaling rates are provided:

- Basic range: $+1\%$ to -2.5%
- Extended overspeed range: $+2.3\%$ to -2.5%

When the transmit converter is operating at the basic signaling rate, no more than one stop bit will be deleted per eight consecutive characters. When operating at the extended rate, no more than one stop bit will be deleted per four consecutive characters. Break handling is performed as described in V.14.

Asynchronous characters are accepted on the TXD serial input and are issued on the RXD serial output.

V.54 Inter-DCE Signaling (-D / -D90)

The modem supports V.54 inter-DCE signaling procedures in synchronous and asynchronous configurations. Transmission and detection of the preparatory, acknowledgment, and termination phases as defined in V.54 are provided. Three control bits (V54T, V54A, and V54P) in the transmitter allow the host to send the appropriate bit patterns. Three control bits (V54TE, V54AE, and V54PE) in the receiver are used to enable one of three bit pattern detectors. A status bit (V54DT) indicates when the selected pattern detector has found the corresponding bit pattern.

V.13 Remote RTS Signaling (-D / -D90)

The modem supports V.13 remote RTS signaling. Transmission and detection of signaling bit patterns in response to a change of state in the RTS bit or the /RTS input signal are provided. This feature may be used to clamp/unclamp the local /RLSD and RXD signals in response to a change in the remote /RTS signal in order to simulate controlled carrier operation in a constant carrier environment. The modem automatically clamps and unclamps /RLSD.

In-Band Secondary Channel (-D / -D90)

A duplex in-band secondary channel is provided in V.34 (all speeds) and V.32 bis/V.32 (7200 bps and above) modes. The secondary channel operates in parallel data mode with independent transmit and receive interrupts and data buffers. The main channel may operate in parallel or serial mode.

In V.34 modes, the secondary channel rate is 200 bps.

In V.32 bis/V.32 modes, the secondary channel rate is 150 bps. This rate is also host programmable in V.32 bis/V.32 modes.

Transmit and Receive FIFO Data Buffers

Two 16-byte first-in first-out (FIFO) data buffers allow the DTE/host to output up to 16 bytes of transmit data to the transmitter FIFO (TXFIFO) and input up to 16 bytes of accumulated received data from the receiver FIFO (RXFIFO). The TXFIFO and RXFIFO can be extended up to 255 bytes. The size of the FIFO extension is 255 bytes overall and can be divided between the two FIFOs in any proportion.

The RXFIFO is always enabled. The host can enable the TXFIFO. Status bits indicate when the TXFIFO is not full, the TXFIFO is half-full (eight or more bytes loaded), the RXFIFO is empty, and the RXFIFO is half-full. An interrupt mask register allows an interrupt request to be generated whenever the status bits change state.

DMA Support for Interrupt Request Lines

DMA support is available in synchronous data modes. When DMA support is enabled, the modem /RI and /DSR lines are assigned to Transmitter Request (TXRQ) and Receiver Request (RXRQ) hardware output interrupt request lines, respectively. The TXRQ and RXRQ signals follow the assertion of the Transmit Data Buffer Empty (TDBE) and Receive Data Buffer Full (RDBF) interrupt bits, thereby allowing the DTE/host to respond immediately to the interrupt request without masking out status bits to determine the interrupt source.

Quick Start for V.34 Half-Duplex (Conexant Proprietary)

V.34 Fax Quick Startup eliminates the V.8 phase 1 segment and uses a shortened training sequence during phase 3, which can save up to 50% of the initial Phase 1 to Phase 4 start up time for normal V.34 half-duplex connection.

ADPCM Voice Mode

The Adaptive Differential Pulse Code Modulation (ADPCM) voice coder and decoder (codec) compresses and decompresses voice signals for efficient digital storage of voice messages. The codec operates at 28.8 kbps, 21.6 kbps, or 14.4 kbps (4-bit, 3-bit, or 2-bit quantization, respectively) with an 8.0 kHz sampling rate.

Caller ID Demodulation

Caller ID information can be demodulated in the V.23 1200 receive configuration and presented to the DTE/host in serial (RXD) or parallel (RBUFFER) form.

Call Waiting Detector

A tone detector is provided to perform call waiting detection and is available in V.90, V.34, V.32bis, V.32, V.17, V.29, and V.27ter modes. By default, call waiting tone levels down to approximately -28 dBm can be detected. The detector can tolerate near-end echo levels up to 10 dB above the call waiting tone level.

Telephone Line Interface

Line Transformer Interface. V.90/V.34 places high requirements upon the Data Access Arrangement (DAA) connection to the telephone line. Due to the wider bandwidth requirement of V.90 and V.34, the DAA must maintain linearity from 150 to 3950 Hz for V.34, and from 10 to 4000 Hz for V.90.

Relay Control. Direct control of the off-hook and talk/data relays is provided. Internal relay drivers allow direct connection to the off-hook and talk/data relays. The talk/data relay output can optionally be used for pulse dial.

Speaker Interface. A SPKR output is provided with on/off and volume control logic incorporated in the modem, requiring only an external amplifier to drive a speaker.

Hardware Interface Signals

Figure 1 illustrates the functional interface signals. In this diagram, an active low signal is indicated by a forward slash "/" (e.g., /RESET). A clock intended to activate logic on its rising edge (low-to-high transition) is called active high (e.g., TDCLK), while a clock intended to activate logic on its falling edge (high-to-low transition) is called active low (e.g., /RDCLK).

Figure 2 illustrates the modem pin assignments. Table 3 provides the signal descriptions.

Power and Maximum Ratings

Table 4 lists the current and power requirements. Table 5 lists the absolute maximum ratings.

Clock Sources

The modem is offered in two configurations depending upon the selected clock source. One configuration utilizes a crystal source and the other uses an oscillator source.

For the crystal configuration, the crystal is connected to XTLI (pin 85) and XTLO (pin 86). For the oscillator source, the oscillator is connected to CLKIN (pin 85) and XTLO (pin 86) is not connected.

Package Dimensions

Figure 3 shows the package dimensions.

Additional Information

Additional design information is described in the *FM336Plus V.34/Group3 High Performance Fax Modem Designer's Guide*.

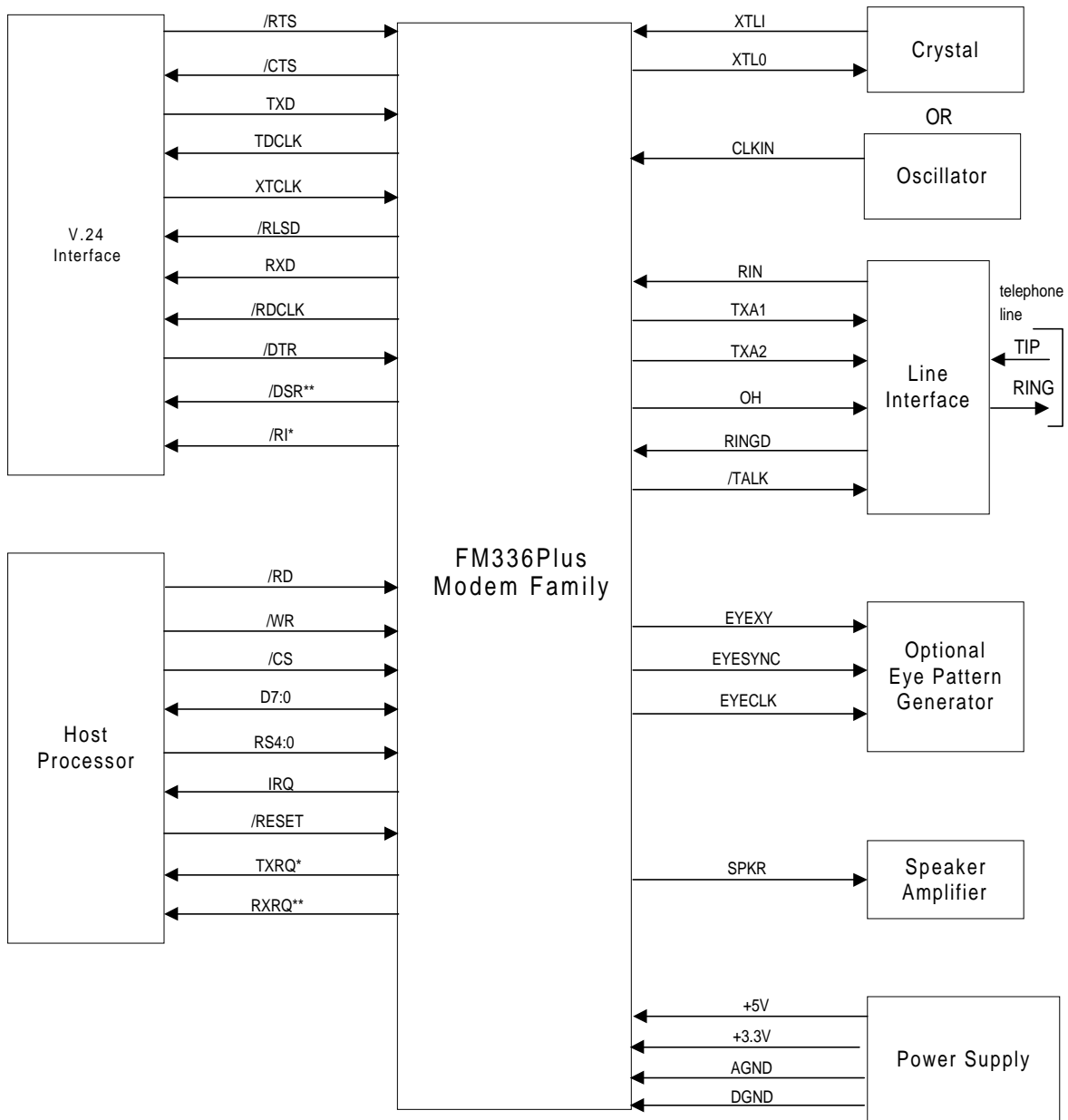

* Selectable; TXRQ output replaces /RI output.
 ** Selectable; RXRQ output replaces /DSR output.

Figure 1. Functional Interface Signals

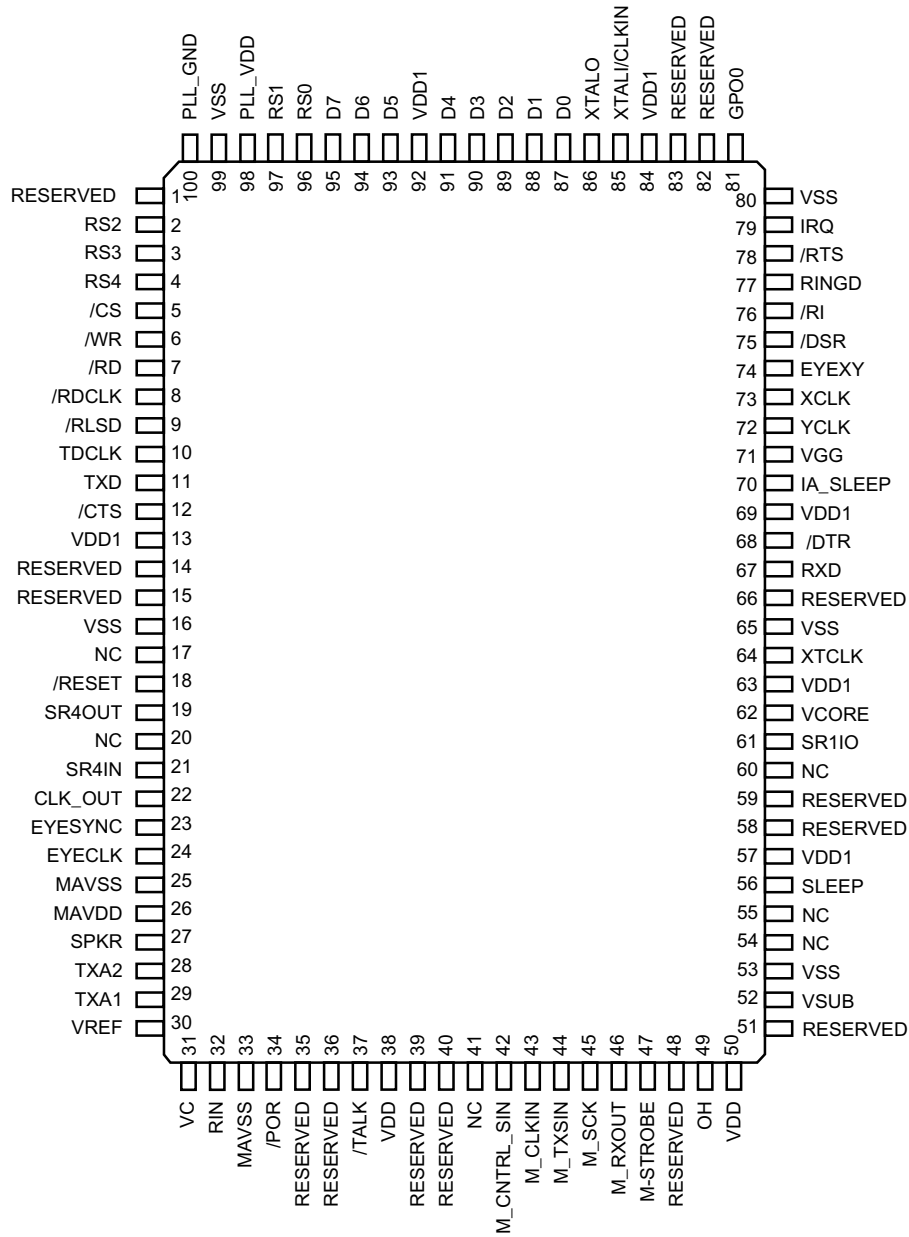

Figure 2. FM336Plus Family Modem Pin Assignments—100-Pin PQFP

Table 3. Signal Descriptions

Pin	Signal Label	I/O Type	Interface	Pin	Signal Label	I/O Type	Interface
1	RESERVED	—	—	51	RESERVED	—	—
2	RS2	IA	HOST Interface	52	VSUB	GND	—
3	RS3	IA	HOST Interface	53	VSS	GND	—
4	RS4	IA	HOST Interface	54	NC	—	NC
5	/CS	IA	HOST Interface	55	NC	—	NC
6	/WR	IA	HOST Interface	56	SLEEP	MI	Modem Interconnect
7	/RD	IA	HOST Interface	57	VDD1	PWR	—
8	/RDCLK	OA	DTE Serial Interface	58	RESERVED	—	—
9	/RLSD	OA	DTE Serial Interface	59	RESERVED	—	—
10	TDCLK	OA	DTE Serial Interface	60	NC	—	NC
11	TXD	IA	DTE Serial Interface	61	SR1IO	MI	Modem Interconnect
12	/CTS	OA	DTE Serial Interface	62	VCORE	PWR	—
13	VDD1	PWR	—	63	VDD1	PWR	—
14	RESERVED	—	—	64	XTCLK	IA	DTE Serial Interface
15	RESERVED	—	—	65	VSS	GND	—
16	VSS	GND	—	66	RESERVED	—	—
17	NC	—	NC	67	RXD	OA	DTE Serial Interface
18	/RESET	OA	Modem Interconnect	68	/DTR	IA	DTE Serial Interface
19	SR4OUT	OA	Modem Interconnect	69	VDD1	PWR	—
20	NC	—	NC	70	IA_SLEEP	MI	Modem Interconnect
21	SR4IN	IA	Modem Interconnect	71	VGG	PWR	—
22	CLK_OUT	OA	Modem Interconnect	72	YCLK	OA	Overhead Signal
23	EYESYNC	OA	Diagnostic Signal	73	XCLK	OA	Overhead Signal
24	EYECLK	OA	Diagnostic Signal	74	EYEXY	OA	Diagnostic Signal
25	MAVSS	GND	—	75	/DSR	OA	DTE Serial Interface
26	MAVDD	PWR	—	76	/RI	OA	Telephone Line Interface
27	SPKR	O(DF)	Telephone Line Interface	77	RINGD	IA	Telephone Line Interface
28	TXA2	O(DD)	Telephone Line Interface	78	/RTS	IA	DTE Serial Interface
29	TXA1	O(DD)	Telephone Line Interface	79	IRQ	OA	HOST Interface
30	VREF	MI	Modem Interconnect	80	VSS	GND	—
31	VC	MI	Modem Interconnect	81	GPO0	MI	Modem Interconnect
32	RIN	I(DA)	Telephone Line Interface	82	RESERVED	—	—
33	MAVSS	AGND	—	83	RESERVED	—	—
34	/POR	IA	Modem Interconnect	84	VDD1	PWR	—
35	RESERVED	—	—	85	XTALI/CLKIN	I	Overhead Signal
36	RESERVED	—	—	86	XTALO	O	Overhead Signal
37	/TALK	O(DD)	Telephone Line Interface	87	D0	IA/OB	HOST Interface
38	VDD	PWR	—	88	D1	IA/OB	HOST Interface
39	RESERVED	—	—	89	D2	IA/OB	HOST Interface
40	RESERVED	—	—	90	D3	IA/OB	HOST Interface
41	NC	—	NC	91	D4	IA/OB	HOST Interface
42	M_CNTRL_SIN	IA	Modem Interconnect	92	VDD1	PWR	—
43	M_CLKIN	IA	Modem Interconnect	93	D5	IA/OB	HOST Interface
44	M_TXSIN	IA	Modem Interconnect	94	D6	IA/OB	HOST Interface
45	M_SCK	IA	Modem Interconnect	95	D7	IA/OB	HOST Interface
46	M_RXOUT	IA	Modem Interconnect	96	RS0	IA/OB	HOST Interface
47	M_STROBE	IA	Modem Interconnect	97	RS1	IA/OB	HOST Interface
48	RESERVED	—	—	98	PLL_VDD	PWR	—
49	OH	O(DD)	Telephone Line Interface	99	VSS	GND	—
50	VDD	PWR	—	100	PLL_GND	GND	—

Notes:

- I/O types:
MI = Modem interconnect
IA, IB = Digital input
OA, OB = Digital output
I(DA) = Analog input
O(DD), O(DF) = Analog output
- NC = No external connection required
RESERVED = No external connection allowed
- Interface Legend:
HOST = Modem Control Unit (Host)
DTE = Data Terminal Equipment

Table 4. Current and Power Requirements

Mode	Current (ID)		Power (PD)		Notes
	Typical Current (mA) @ 25° C	Maximum Current (mA) @ 0° C	Typical Power (mW) @ 25° C	Maximum Power (mW) @ 0° C	
Normal mode	76	88	250	320	
Sleep mode	6	8	20	30	

Note:
Test conditions: VDD = +3.3 VDC for typical values; VDD = +3.63 VDC for maximum values.

Table 5. Absolute Maximum Ratings

Parameter	Symbol	Limits	Units
Supply Voltage	V_{DD1}	-0.5 to +3.6	V
Digital Input Voltage	V_{IND}	-0.5 to (+5VD + 0.5)	V
Operating Temperature Range	T_A	-0 to +70	° C
Storage Temperature Range	T_{STG}	-55 to +125	° C
Analog Input Voltage	V_{INA}	-0.3 to (+5VA + 0.3)	V
Voltage Applied to Outputs in High Impedance (Off) State	V_{HZ}	-0.5 to (+5VD + 0.5)	V
DC Input Clamp Current	I_{IK}	±20	mA
DC Output Clamp Current	I_{OK}	±20	mA
Static Discharge Voltage (25 °C)	V_{ESD}	±2500	V
Latch-up Current (25 °C)	I_{TRIG}	±200	mA

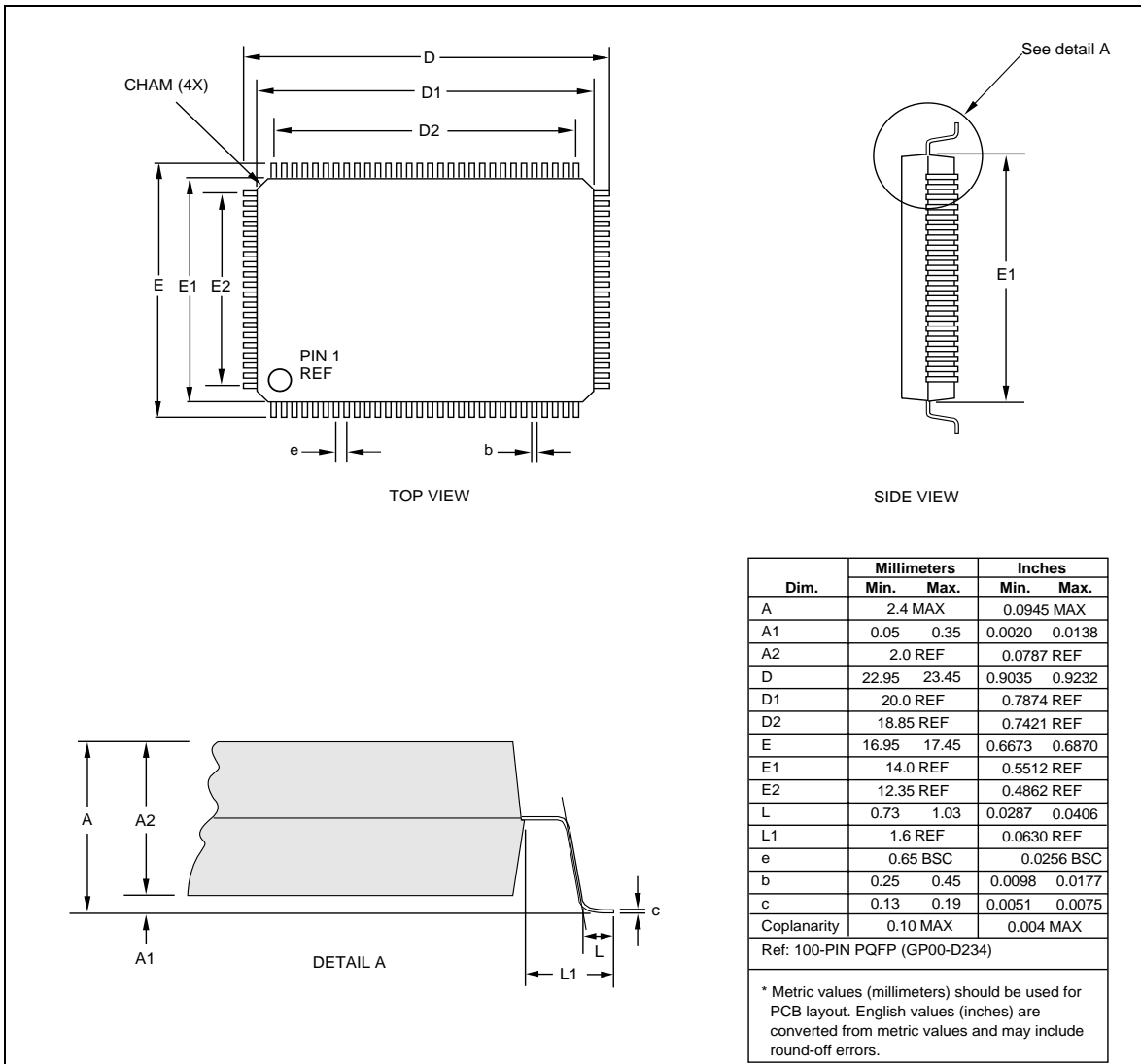

Figure 3. Package Dimensions—100-Pin PQFP

PD-PQFP-100 (040695)

INSIDE COVER BACK PAGE

**Further Information**

literature@conexant.com
(800) 854-8099 (North America)
(949) 483-6996 (International)
Printed in USA

World Headquarters

Conexant Systems, Inc.
4311 Jamboree Road
Newport Beach, CA
92660-3007
Phone: (949) 483-4600
Fax 1: (949) 483-4078
Fax 2: (949) 483-4391

Americas**U.S. Northwest/****Pacific Northwest – Santa Clara**

Phone: (408) 249-9696
Fax: (408) 249-7113

U.S. Southwest – Los Angeles

Phone: (805) 376-0559
Fax: (805) 376-8180

U.S. Southwest – Orange County

Phone: (949) 483-9119
Fax: (949) 483-9090

U.S. Southwest – San Diego

Phone: (858) 713-3374
Fax: (858) 713-4001

U.S. North Central – Illinois

Phone: (630) 773-3454
Fax: (630) 773-3907

U.S. South Central – Texas

Phone: (972) 733-0723
Fax: (972) 407-0639

U.S. Northeast – Massachusetts

Phone: (978) 367-3200
Fax: (978) 256-6868

U.S. Southeast – North Carolina

Phone: (919) 858-9110
Fax: (919) 858-8669

U.S. Southeast – Florida/

South America
Phone: (727) 799-8406
Fax: (727) 799-8306

U.S. Mid-Atlantic – Pennsylvania

Phone: (215) 244-6784
Fax: (215) 244-9292

Canada – Ontario

Phone: (613) 271-2358
Fax: (613) 271-2359

Europe**Europe Central – Germany**

Phone: +49 89 829-1320
Fax: +49 89 834-2734

Europe North – England

Phone: +44 1344 486444
Fax: +44 1344 486555

Europe – Israel/Greece

Phone: +972 9 9524000
Fax: +972 9 9573732

Europe South – France

Phone: +33 1 41 44 36 51
Fax: +33 1 41 44 36 90

Europe Mediterranean – Italy

Phone: +39 02 93179911
Fax: +39 02 93179913

Europe – Sweden

Phone: +46 (0) 8 5091 4319
Fax: +46 (0) 8 590 041 10

Europe – Finland

Phone: +358 (0) 9 85 666 435
Fax: +358 (0) 9 85 666 220

Asia – Pacific**Taiwan**

Phone: (886-2) 2-720-0282
Fax: (886-2) 2-757-6760

Australia

Phone: (61-2) 9869 4088
Fax: (61-2) 9869 4077

China – Central

Phone: 86-21-6361-2515
Fax: 86-21-6361-2516

China – South

Phone: (852) 2 827-0181
Fax: (852) 2 827-6488

China – South (Satellite)

Phone: (86) 755-518-2495

China – North

Phone: (86-10) 8529-9777
Fax: (86-10) 8529-9778

India

Phone: (91-11) 692-4789
Fax: (91-11) 692-4712

Korea

Phone: (82-2) 565-2880
Fax: (82-2) 565-1440

Korea (Satellite)

Phone: (82-53) 745-2880
Fax: (82-53) 745-1440

Singapore

Phone: (65) 737 7355
Fax: (65) 737 9077

Japan

Phone: (81-3) 5371 1520
Fax: (81-3) 5371 1501

This datasheet has been download from:

www.datasheetcatalog.com

Datasheets for electronics components.