

3469674 FAIRCHILD SEMICONDUCTOR 84 DE 3469674 0027830 7

FAIRCHILD

A Schlumberger Company

FMP20N05/FMP18N05 T-39-11
N-Channel Power MOSFETs,
18-20 A, 50 V

Power And Discrete Division

Description

These devices are very low $R_{DS(on)}$, 50 V, n-channel, enhancement mode, power MOSFETs especially designed to serve the low voltage, high speed, switching markets. Typical applications are SMPS for telecommunication and instrumentation, DC motor controls, emitter switching, synchronous rectification, and systems that are operated from low voltage batteries, such as automotive and portable equipment, etc.

TO-220AB

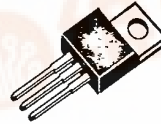

1800000F

FMP18N05
 FMP20N05

- Extremely low $R_{DS(on)}$
- V_{GS} Rated at ± 30 V
- Silicon Gate for Fast Switching Speeds
- Rugged
- Low Drive Requirements
- Ease of Paralleling

Maximum Ratings

Symbol	Characteristic	Rating FMP20N05	Rating FMP18N05	Unit
V_{DSS}	Drain to Source Voltage ¹	50	50	V
V_{DGR}	Drain to Gate Voltage ¹ $R_{GS} = 20 \text{ k}\Omega$	50	50	V
V_{GS}	Gate to Source Voltage	± 30	± 30	V
T_J, T_{stg}	Operating Junction and Storage Temperatures	-55 to +150	-55 to +150	$^{\circ}\text{C}$
T_L	Maximum Lead Temperature for Soldering Purposes, 1/8" From Case for 5 s	300	300	$^{\circ}\text{C}$

Maximum On-State Characteristics

		FMP20N05	FMP18N05	
$R_{DS(on)}$	Static Drain-to-Source On Resistance	0.085	0.10	Ω
I_D	Drain Current			A
	Continuous at $T_C = 25^{\circ}\text{C}$	20	18	
	Continuous at $T_C = 100^{\circ}\text{C}$	14	13	
	Pulsed	60	50	

Maximum Thermal Characteristics

$R_{\theta JC}$	Thermal Resistance, Junction to Case	1.67	1.67	$^{\circ}\text{C}/\text{W}$
$R_{\theta JA}$	Thermal Resistance, Junction to Ambient	80	80	$^{\circ}\text{C}/\text{W}$
P_D	Total Power Dissipation at $T_C = 25^{\circ}\text{C}$	75	75	W

Notes

For information concerning connection diagram and package outline, refer to Section 7.



FMP20N05
FMP18N05

T-39-11

Electrical Characteristics ($T_C = 25^\circ\text{C}$ unless otherwise noted)

Symbol	Characteristic	Min	Max	Unit	Test Conditions
Off Characteristics					
$V_{(BR)DSS}$	Drain Source Breakdown Voltage ¹	50		V	$V_{GS} = 0\text{ V}$, $I_D = 250\ \mu\text{A}$
I_{DSS}	Zero Gate Voltage Drain Current		250	μA	$V_{DS} = \text{Rated } V_{DSS}$, $V_{GS} = 0\text{ V}$
			1000	μA	$V_{DS} = 0.8 \times \text{Rated } V_{DSS}$, $V_{GS} = 0\text{ V}$, $T_C = 125^\circ\text{C}$
I_{GSS}	Gate-Body Leakage Current		± 500	nA	$V_{GS} = \pm 20\text{ V}$, $V_{DS} = 0\text{ V}$
On Characteristics					
$V_{GS(th)}$	Gate Threshold Voltage	2.0	4.0	V	$I_D = 250\ \mu\text{A}$, $V_{DS} = V_{GS}$
$R_{DS(on)}$	Static Drain-Source On-Resistance ²			Ω	$V_{GS} = 10\text{ V}$, $I_D = 10\text{ A}$
		FMP20N05	0.085		
		FMP18N05	0.10		
$V_{DS(on)}$	Drain-Source On-Voltage ²		2.0	V	$V_{GS} = 10\text{ V}$; $I_D = 20\text{ A}$;
		FMP18N05	2.25		
		FMP20N05 FMP18N05	1.40	V	$V_{GS} = 10\text{ V}$; $I_D = 10\text{ A}$; $T_C = 100^\circ\text{C}$
g_{fs}	Forward Transconductance	5		S (Ω)	$V_{DS} = 10\text{ V}$, $I_D = 10\text{ A}$
Dynamic Characteristics					
C_{iss}	Input Capacitance		850	pF	$V_{DS} = 25\text{ V}$, $V_{GS} = 0\text{ V}$ $f = 1.0\text{ MHz}$
C_{oss}	Output Capacitance		400	pF	
C_{rss}	Reverse Transfer Capacitance		150	pF	
Switching Characteristics ($T_C = 25^\circ\text{C}$, Figures 9, 10)					
$t_{d(on)}$	Turn-On Delay Time		50	ns	$V_{DD} = 40\text{ V}$, $I_D = 10\text{ A}$ $V_{GS} = 10\text{ V}$, $R_{GEN} = 50\ \Omega$ $R_{GS} = 50\ \Omega$
t_r	Rise Time		90	ns	
$t_{d(off)}$	Turn-Off Delay Time		60	ns	
t_f	Fall Time		75	ns	
Q_g	Total Gate Charge		20	nC	$V_{GS} = 10\text{ V}$, $I_D = 25\text{ A}$ $V_{DD} = 40\text{ V}$
Symbol Characteristic Typ Max Unit Test Conditions					
Source-Drain Diode Characteristics					
V_{SD}	Diode Forward Voltage		1.5	V	$I_S = 20\text{ A}$; $V_{GS} = 0\text{ V}$
t_{rr}	Reverse Recovery Time	60		ns	$I_S = 20\text{ A}$; $di_S/dt = 50\text{ A}/\mu\text{S}$

Notes

- $T_J = +25^\circ\text{C}$ to $+150^\circ\text{C}$
- Pulse test: Pulse width $\leq 80\ \mu\text{s}$, Duty cycle $\leq 1\%$

FMP20N05
FMP18N05

T-39-11

Typical Performance Curves

Figure 1 Output Characteristics

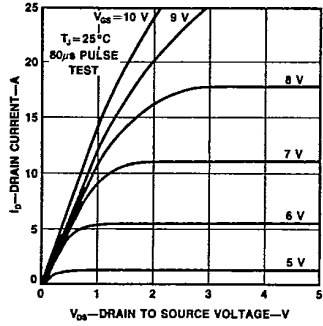

PC11415F

Figure 2 Static Drain to Source Resistance vs Drain Current

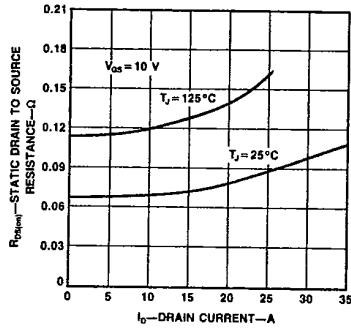

PC11420F

Figure 3 Transfer Characteristics

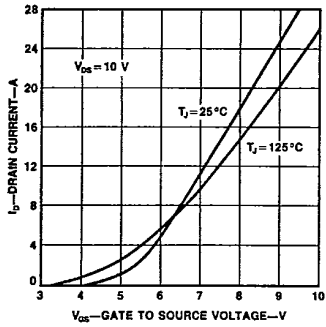

PC11430F

Figure 4 Temperature Variation of Gate to Source Threshold Voltage

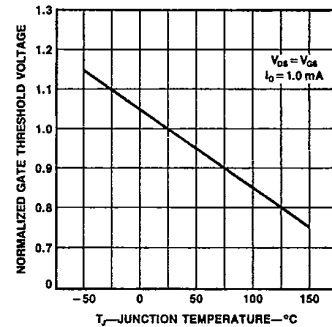

PC00841F

Figure 5 Capacitance vs Drain to Source Voltage

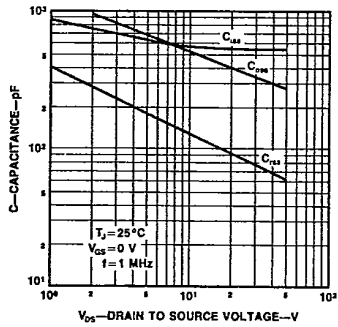

PC11440F

Figure 6 Gate to Source Voltage vs Total Gate Charge

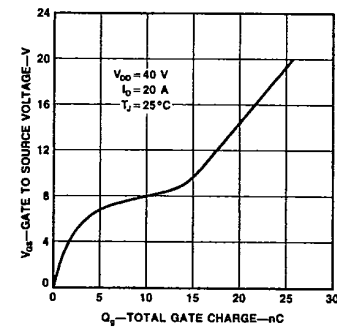

PC11450F

FMP20N05
FMP18N05

T-39-11

Typical Performance Curves (Cont.)

Figure 7 Forward Biased Safe Operating Area

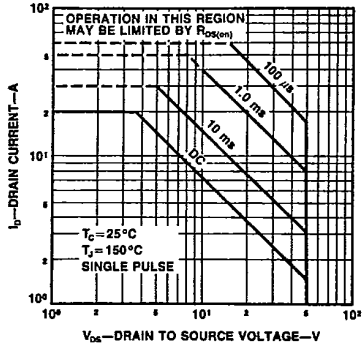

PC11460F

Figure 8 Transient Thermal Resistance vs Time

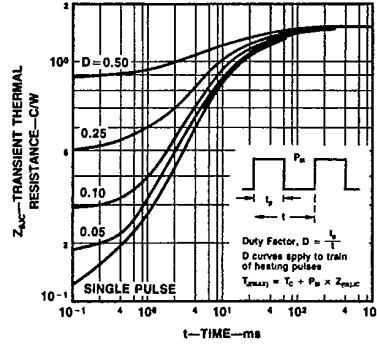

PC11470F

Typical Electrical Characteristics

Figure 9 Switching Test Circuit

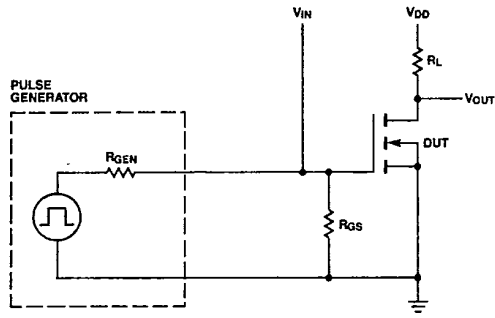

CR04430F

Figure 10 Switching Waveforms

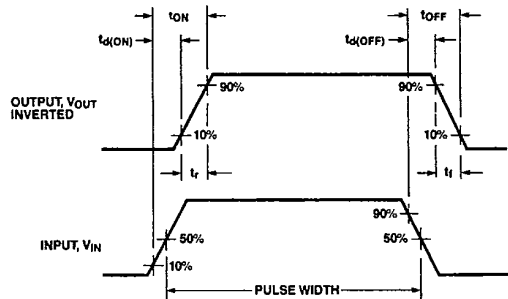

W700600F