

FMS6366

Selectable YPbPr HD/SD 4:2:2 Video Filter Driver with Y, C and Composite Outputs

Features

- Pin-compatible version of the FMS6419 for 4:2:2 video
- Requires external delay compensation
- 6th order Standard / High Definition video filters
- YPbPr 4:2:2 filters (8/30MHz : 4/15MHz : 4/15MHz)
- YC Standard Definition filters (8MHz)
- Composite summer output
- DC-coupled inputs, AC-coupled outputs
- Outputs provide 6dB gain to 150Ω AC-coupled loads
- Dual multiplexed inputs
- 0.3% differential gain with 0.1° differential phase
- 5V only
- Lead free (Pb-free) packaging

Applications

- Cable Set top boxes
- Satellite Set top boxes
- DVD players
- HDTV
- Personal Video Recorders (PVR)
- Video On Demand (VOD)

Description

The FMS6366 Filter Driver offers comprehensive filtering for set top box or DVD applications. This part consists of triple 6th order filters with selectable cutoffs for SD or HD. The filters are in a 4:2:2 configuration such that Y1 switches between 8MHz (SD) and 30MHz (HD). The Pb and Pr channels switch between 4MHz (SD) and 15MHz (HD). The required delay compensation must be performed in the digital domain prior to filtering by the FMS6366.

An additional S-video path is provided for SD signals. The Y2 and C signals are both filtered at 8MHz. A composite summer is included to provide a composite output based on Y2 and C.

A 2:1 multiplexer is provided on each filter channel with separate select lines for the YPbPr and YC signals.

All inputs accept DC-coupled ground referenced 1Vpp input signals. The filter outputs include +6dB of gain resulting in a 2Vpp signal into an AC-coupled dual video load (75Ω).

Functional Block Diagram

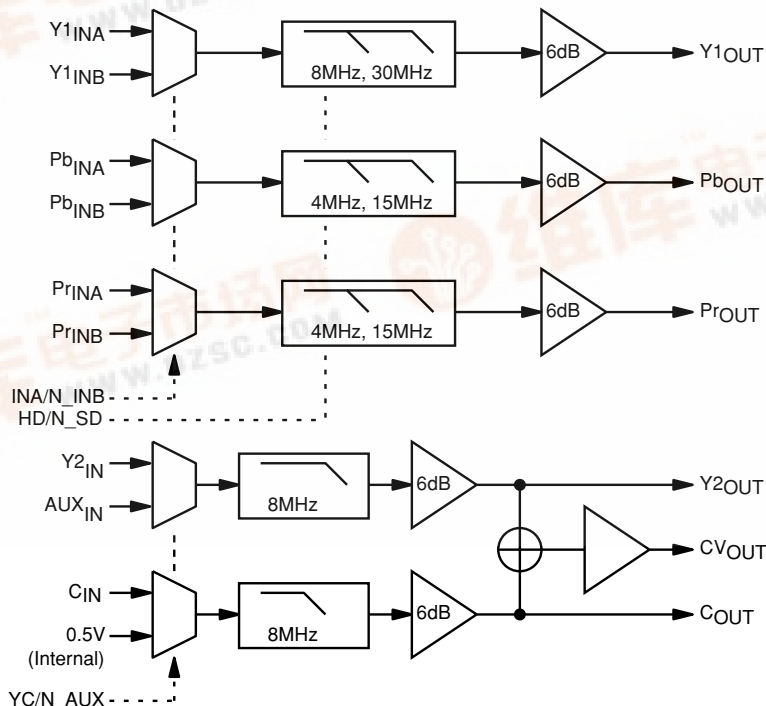

DC Specifications

($T_C = 25^\circ\text{C}$, $V_i = 1V_{PP}$; $V_{CC} = 5.0V$, all inputs AC coupled with $0.1\mu\text{F}$, all outputs AC coupled with $220\mu\text{F}$ into 150Ω , referenced to 400kHz ; unless otherwise noted)

Symbol	Parameter	Conditions	Min	Typ	Max	Units
I_{CC}	Supply Current ¹	V_{CC} no load		125	150	mA
V_i	Input Voltage Max	Reference to ground		1.3		V
V_{il}	Digital Input Low ¹	INA, HD, YC	0		0.8	V
V_{ih}	Digital Input High ¹	INA, HD, YC	2.4		V_{CC}	V
PSRR	PSRR (all channels)	DC		-40		dB

Standard Definition Electrical Specifications

($T_C = 25^\circ\text{C}$, $V_i = 1V_{PP}$; $V_{CC} = 5.0V$, $HD/N_SD = 0$, $R_{SOURCE} = 37.5\Omega$, all inputs AC coupled with $0.1\mu\text{F}$, all outputs AC coupled with $220\mu\text{F}$ into 150Ω , referenced to 400kHz ; unless otherwise noted)

Symbol	Parameter	Conditions	Min	Typ	Max	Units
AV_{SD}	SD Gain ¹	All channels	5.4	6.0	6.6	dB
f_{1dBSD4}	-1dB Bandwidth for SD ¹	Y1, Y2, C	4.0	7.4		MHz
f_{1dBSD2}		Pb, Pr	2.0	3.9		MHz
f_{CSD4}	-3dB Bandwidth for SD	Y1, Y2, C		8.5		MHz
f_{CSD2}		Pb, Pr		4.5		MHz
f_{SBS}	Attenuation: SD (stopband reject) ¹	All channels at $f = 27\text{MHz}$	37	55		dB
dG	Differential Gain	All channels		0.3		%
d ϕ	Differential Phase	All channels		0.1		°
THD	Output Distortion (all channels)	$V_{OUT} = 1.8V_{pp}$ at 1MHz		0.15		%
$X_{TALKYPbPr}$	Crosstalk (channel-to-channel)	$V_{OUT} = 1.8V_{pp}$ at 1MHz , YPbPr		-70		dB
$X_{TALKYCCV}$	Crosstalk (channel-to-channel)	$V_{OUT} = 1.8V_{pp}$ at 1MHz , YCCV		-62		dB
IN_{MUXISO}	IN_{MUX} Isolation	$V_{IN} = 1V_{pp}$ at 1MHz		-70		dB
SNR	Signal-to-Noise Ratio	All channels, NTC-7 weighting 4.2MHz lowpass, 100kHz highpass		70		dB
t_{pdSD4}	Input to Output Prop Delay for SD	Y1, Y2, C, CV In to Out at 400kHz		75		ns
t_{pdSD2}		Pb, Pr In to Out at 400kHz		135		ns
$t_{42SDYPbPr}$	4:2:2 Filter delay (compensate in the digital domain)	Y1 to Pb/Pr delay		60		ns
t_{CLDCV}	Chroma-Luma delay CV_{OUT} ¹	$f = 3.58\text{MHz}$	-35	-4	35	ns
t_{CLGCV}	Chroma-Luma gain CV_{OUT} ¹	$f = 3.58\text{MHz}$	95	100	105	%

High Definition Electrical Specifications

($T_C = 25^\circ\text{C}$, $V_i = 1V_{pp}$; $V_{CC} = 5.0V$, $HD/N_SD = 1$, $R_{SOURCE} = 37.5\Omega$, all inputs AC coupled with $0.1\mu\text{F}$, all outputs AC coupled with $220\mu\text{F}$ into 150Ω , referenced to 400kHz ; unless otherwise noted)

Symbol	Parameter	Conditions	Min	Typ	Max	Units
AV_{HD}	HD Gain ¹	Y1, Pb, Pr in HD Mode	5.4	6.0	6.6	dB
f_{1dBHD4}	-1dB Bandwidth for HD ¹	Y1	20	27		MHz
f_{1dBHD2}		Pb, Pr	10	14.2		MHz

Symbol	Parameter	Conditions	Min	Typ	Max	Units
f_{CHD4}	-3dB Bandwidth for HD	Y1		31.5		MHz
f_{CHD2}		Pb, Pr		16		MHz
f_{SBHD}	Attenuation: HD (stopband reject) ¹	All Channels at $f = 74.25\text{MHz}$	35	40		dB
t_{pdHD4}	Prop Delay for HD	Y1 delay In to Out at 400kHz		25		ns
t_{pdHD2}		Pb, Pr delay In to Out at 400kHz		40		ns
$t_{42\text{HDYPbPr}}$	4:2:2 Filter delay (compensate in the digital domain)	Y1 to Pb/Pr delay		15		ns

Note:

1. 100% tested at 25°C

Absolute Maximum Ratings (beyond which the device may be damaged)

Parameter	Min	Max	Units
DC Supply Voltage	-0.3	6	V
Analog and Digital I/O	-0.3	$V_{\text{CC}} + 0.3$	V
Output Current Any One Channel, Do Not Exceed		50	mA

Reliability Information

Parameter	Min	Typ	Max	Units
Junction Temperature			150	°C
Storage Temperature Range	-65		150	°C
Lead Temperature (Soldering, 10s)			300	°C
Thermal Resistance (Θ_{JA}), JEDEC Standard Multi-layer Test Boards, Still Air		47		°C/W

Recommended Operating Conditions

Parameter	Min	Typ	Max	Units
Operating Temperature Range	0		70	°C
V_{CC} Range	4.75	5.0	5.25	V

Description

The FMS6366 offers comprehensive filtering for set top box or DVD applications. This part consists of triple 4:2:2 6th order filters with selectable 30/15MHz or 8/4MHz frequencies for YPbPr and a dual 8MHz filter for YC with a composite summer. Two-to-one multiplexers are provided on the triple filters as well as provisions for auxiliary input to the composite channel. The triple filters are intended for YPbPr signals. All channels accept DC coupled ground-referenced 1Vpp signals. The filters output 2Vpp signals into AC coupled terminated loads.

The FMS6366 is a next generation filter solution from Fairchild Semiconductor addressing the expanding filtering needs for set top boxes, and DVD players. The product provides selectable 4:2:2 HD/SD filtering on the YPbPr channels. Thus, the FMS6366 addresses the requirement for a single

set top box to be compatible with a variety of resolution standards. Additionally, the product provides additional filters for Y, C, and Composite Video (CV) outputs. Multiplexers on the YPbPr and CV channels provide further flexibility.

For DVD applications, the product provides filtering and output drive amplification for 6 channels of outputs. These include Y1, Pb, Pr, Y2, C, and CV outputs.

For Set top boxes, this product provides two channels of filtered video with the flexibility of selectable high order filtering for multiple resolution standards. Additional flexibility is provided by the Y (Luma) and C (Chroma) filters with a composite summer.

All channels provide 6dB gain, accept 1V ground referenced inputs, and drive AC coupled loads.

Functional Description

DC Levels

At any given time, the input signal's DC levels must be between 0.0V and 1.3V to utilize the optimal headroom and to avoid clipping at the outputs. The Y channels accept 1Vpp signals with the sync tip at ground. The Pb, Pr and C channels should be centered around 0.5V. This will ensure that the filter will utilize the optimal headroom and avoid clipping.

DC-Coupled Output Applications

The 220uF capacitor coupled with the 150Ω termination forms a high pass filter that blocks the DC while passing the video frequencies and avoiding tilt. Lower values such as 10uF cause unacceptable tilt in the output signal. By AC coupling, the average DC level is zero. Thus, the output voltages of all channels will be centered around zero.

DC coupling the output of the FMS6366 is allowable, but not recommended. There are several trade-offs: The average DC level on the outputs will be 2V. Each output will dissipate an additional 40mW nominally. The application will need to accommodate a 1V DC offset sync tip. Also, it is recommended to limit one 150Ω load per output.

The FMS6366 is specified to operate with output currents typically less than 50mA, more than sufficient for a dual (75Ω) video load. Internal amplifiers are current limited to a maximum of 100mA and should withstand brief duration short circuit conditions, however this capability is not guaranteed.

Driving Digital Pins

The FMS6366 digital inputs are compatible with most 3.3V and 5V logic. Verify that the V_{ih} and V_{il} are within the specified limits.

Applications

A typical application for the FMS6366 is shown in Figure 1.

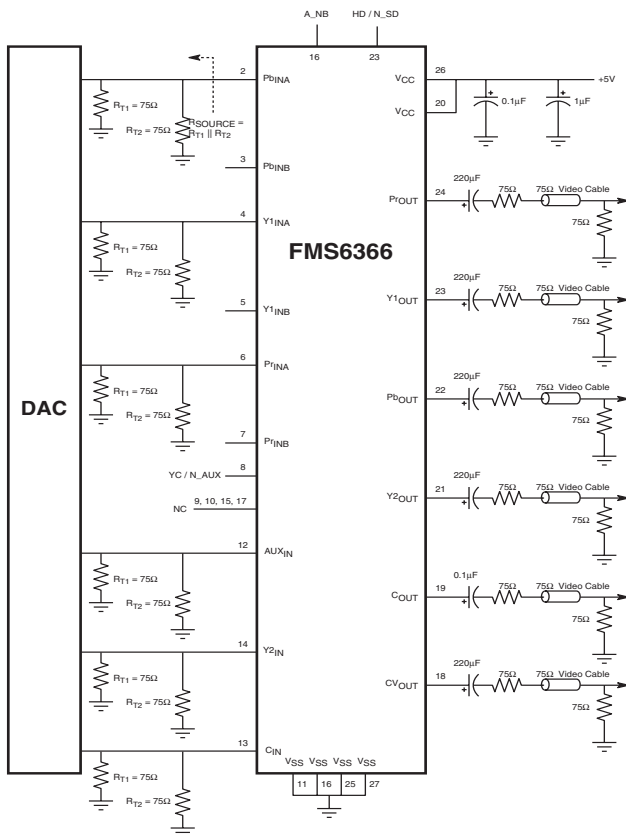

Figure 1: Typical Application Diagram

Digital Delay Compensation

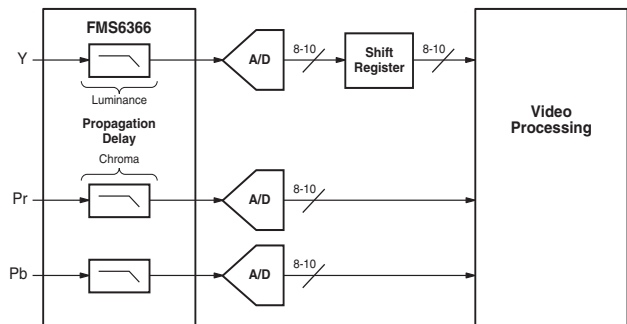

Figure 2: Digital Delay Compensation for anti-alias 4:2:2 filters

The Chroma filters are one half the bandwidth of the Luminance filter therefore the propagation delay time through the Chroma filter is longer than the Luminance filter. In the Standard Definition (SD) case, the Chroma filter propagation delay is typically 60 nanoseconds longer than the Luminance filter. This is three clock cycles at 54MHz so it is easily corrected by adding digital delay as shown in Figure 3 and illustrated as a shift register in Figure 2. In the High Definition (HD) setting the Chroma filter propagation delay is typically 15 nanoseconds longer than the Luminance filter. This is one clock cycle at 74.25MHz so it is also easily corrected by adding digital delay to the luminance path.

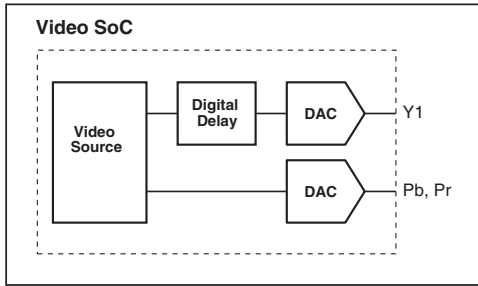
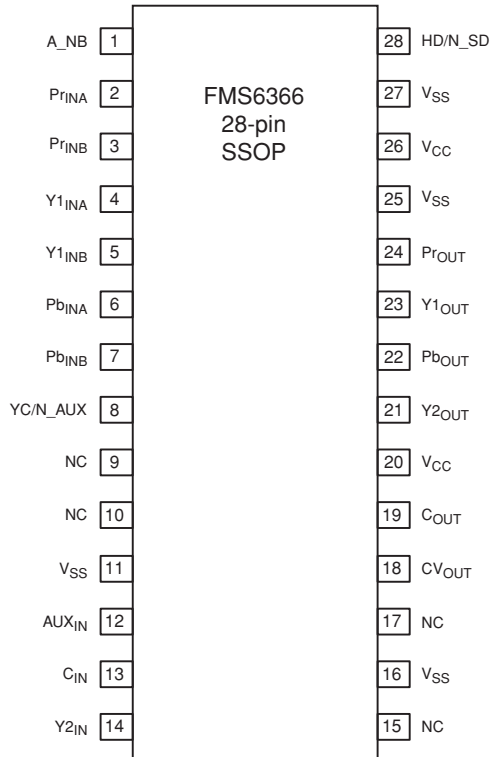

Figure 3: Digital Delay Compensation for 4:2:2 reconstruction filters

Pin Configuration



Pin Descriptions

Pin#	Pin	Type	Description
1	A_NB	INPUT	Logic input selects between channel <A> or . (1): A input, (0): B input
2	Pr_INA	INPUT	Pr input, channel A
3	Pr_INB	INPUT	Pr input, channel B
4	Y1_INA	INPUT	Y1 (Luminance) input, channel A. Must include sync.
5	Y1_INB	INPUT	Y1 (Luminance) input, channel B. Must include sync.
6	Pb_INA	INPUT	Pb input, channel A
7	Pb_INB	INPUT	Pb input, channel B
8	YC/N_AUX	INPUT	Logic input selects between YC and AUX. (1): YC input, (0): AUX input
9	NC		No Connect, leave floating
10	NC		No Connect, leave floating
11	VSS	INPUT	Must be tied to ground, do not float
12	AUX_IN	INPUT	Composite video input
13	C_IN	INPUT	Chrominance input
14	Y2_IN	INPUT	Y2 (Luminance) input. Must include sync.
15	NC		No Connect, leave floating
16	VSS	INPUT	Must be tied to ground, do not float
17	NC		No Connect, leave floating
18	CV_OUT	OUTPUT	Filtered composite video output
19	C_OUT	OUTPUT	Filtered chrominance output
20	VCC	INPUT	+5V supply, do not float
21	Y2_OUT	OUTPUT	Y2 output
22	Pb_OUT	OUTPUT	Pb output
23	Y1_OUT	OUTPUT	Y1 output
24	Pr_OUT	OUTPUT	Pr output
25	VSS	INPUT	Must be tied to ground, do not float
26	VCC	INPUT	+5V supply, do not float
27	VSS	INPUT	Must be tied to ground, do not float
28	HD/N_SD	INPUT	Logic input selects between HD and SD mode. (1): HD, (0): SD

Package Dimensions

SSOP-28

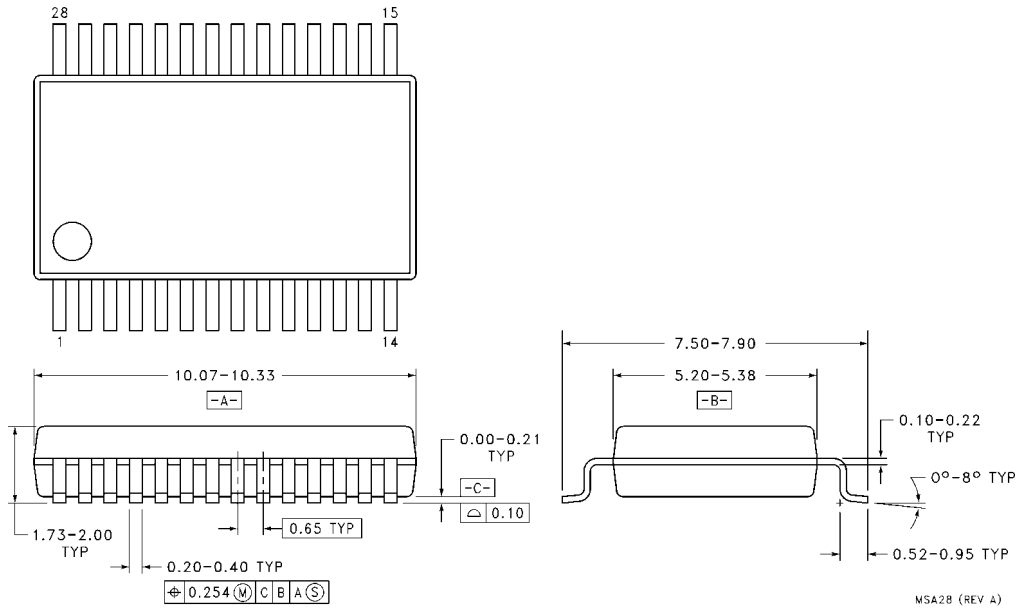

Ordering Information

Model	Part Number	Lead Free	Package	Container	Pack Qty
FMS6366	FMS6366MSA28_NL	Yes	SSOP-28	Rail	47
FMS6366	FMS6366MSA28X_NL	Yes	SSOP-28	Reel	2000

DISCLAIMER

FAIRCHILD SEMICONDUCTOR RESERVES THE RIGHT TO MAKE CHANGES WITHOUT FURTHER NOTICES TO ANY PRODUCTS HEREIN TO IMPROVE RELIABILITY, FUNCTION OR DESIGN. FAIRCHILD DOES NOT ASSUME ANY LIABILITY ARISING OUT OF THE APPLICATION OR USE OF ANY PRODUCT OR CIRCUIT DESCRIBED HEREIN; NEITHER DOES IT CONVEY ANY LICENSE UNDER ITS PATENT RIGHTS, NOR THE RIGHTS OF OTHERS.

LIFE SUPPORT POLICY

FAIRCHILD'S PRODUCTS ARE NOT AUTHORIZED FOR USE AS CRITICAL COMPONENTS IN LIFE SUPPORT DEVICES OR SYSTEMS WITHOUT THE EXPRESS WRITTEN

1. Life support devices or systems are devices or systems which, (a) are intended for surgical implant into the body, or (b) support or sustain life, and (c) whose failure to perform when properly used in accordance with instructions for use provided in the labeling, can be reasonably expected to result in a significant injury of the user.
2. A critical component in any component of a life support device or system whose failure to perform can be reasonably expected to cause the failure of the life support device or system, or to affect its safety or effectiveness.