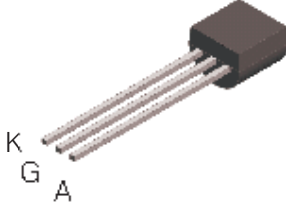
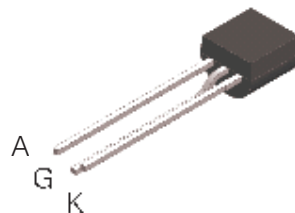
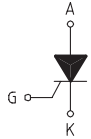

SENSITIVE GATE SCR

TO92 (Plastic)	RD26 (Plastic)	<table border="0" style="width: 100%;"> <tr> <td style="text-align: center;">On-State Current</td> <td style="text-align: center;">Gate Trigger Current</td> </tr> <tr> <td style="text-align: center;">1.25 Amp</td> <td style="text-align: center;">< 200 μA</td> </tr> <tr> <td colspan="2" style="text-align: center;">Off-State Voltage</td> </tr> <tr> <td colspan="2" style="text-align: center;">200 V \div 800 V</td> </tr> </table>	On-State Current	Gate Trigger Current	1.25 Amp	< 200 μ A	Off-State Voltage		200 V \div 800 V	
On-State Current	Gate Trigger Current									
1.25 Amp	< 200 μ A									
Off-State Voltage										
200 V \div 800 V										
 FS02...A	 FS02...B									
		<p>This series of Silicon Controlled Rectifiers uses a high performance PNPN technology.</p> <p>This part is intended for general purpose applications where high gate sensitivity is required.</p>								

Absolute Maximum Ratings, according to IEC publication No. 134

SYMBOL	PARAMETER	CONDITIONS	Value	Unit
$I_{T(RMS)}$	On-state Current	180° Conduction Angle, $T_c = 115\text{ }^\circ\text{C}$	1.25	A
$I_{T(AV)}$	Average On-state Current	Half Cycle, $\Theta = 180^\circ$, $T_c = 115\text{ }^\circ\text{C}$	0.8	A
I_{TSM}	Non-repetitive On-State Current	Half Cycle, 60 Hz	25	A
I_{TSM}	Non-repetitive On-State Current	Half Cycle, 50 Hz	22.5	A
I^2t	Fusing Current	$t_p = 10\text{ms}$, Half Cycle	2.5	A ² s
I_{GM}	Peak Gate Current	20 μ s max.	1.2	A
P_{GM}	Peak Gate Dissipation	20 μ s max.	3	W
$P_{G(AV)}$	Gate Dissipation	20ms max.	0.2	W
T_j	Operating Temperature		(-40 to +125)	$^\circ\text{C}$
T_{stg}	Storage Temperature		(-40 to +150)	$^\circ\text{C}$
T_{sld}	Soldering Temperature	10s max.	260	$^\circ\text{C}$

SYMBOL	PARAMETER	CONDITIONS	VOLTAGE					Unit
			B	D	M	S	N	
V_{DRM} V_{RRM}	Repetitive Peak Off State Voltage	$R_{GK} = 1\text{ k}\Omega$	200	400	600	700	800	V

SENSITIVE GATE SCR

Electrical Characteristics

SYMBOL	PARAMETER	CONDITIONS	SENSITIVITY				Uni	
			01	02	03	04		
I_{GT}	Gate Trigger Current	$V_D = 12 V_{DC}, R_L = 140\Omega, T_j = 25^\circ C$	MIN MAX	1 20	200 200	20 200	15 50	μA
V_{GT}	Gate Trigger Voltage	$V_D = 12 V_{DC}, R_L = 140\Omega, T_j = 25^\circ C$	MAX	0.8				V
V_{GD}	Gate Non Trigger Voltage	$V_D = V_{DRM}, R_L = 3.3k\Omega, R_{GK} = 220\Omega, T_j = 125^\circ C$	MIN	0.1				V
V_{RGM}	Reverse Gate Voltage	$I_{RG} = 10\mu A,$	MIN	8				V
I_H	Holding Current	$I_T = 50 mA, R_{GK} = 1k\Omega, T_j = 25^\circ C$	MAX	5				mA
I_L	Latching Current	$I_G = 1 mA, R_{GK} = 1k\Omega$	MAX	6				mA
dV / dt	Critical Rate of Voltage Rise	$V_D = 0.67 \times V_{DRM}, R_{GK} = 1k\Omega, T_j = 125^\circ C$	MIN	15	15	20	15	V/ μs
dI / dt	Critical Rate of Current Rise	$I_G = 2 \times I_{GT}, tr \leq 100 ns, f = 60 Hz, T_j = 125^\circ C$	MIN	50				A/ μs
V_{TM}	On-state Voltage	at $I_T = 2.5 Amp, tp = 380 \mu s, T_j = 25^\circ C$	MAX	1.45				V
V_{t0}	Threshold Voltage	$T_j = 125^\circ C$	MAX	0.95				V
r_d	Dynamic resistance	$T_j = 125^\circ C$	MAX	400				m Ω
I_{DRM} / I_{RRM}	Off-State Leakage Current	$V_D = V_{DRM}, R_{GK} = 1k\Omega, T_j = 125^\circ C$ $V_R = V_{RRM}, T_j = 25^\circ C$	MAX MAX	100 1				μA μA
$R_{th(j-c)}$	Thermal Resistance Junction-Case for DC	for AC 360° conduction angle		60				°C/W
$R_{th(j-a)}$	Thermal Resistance Junction-Amb for DC	$S = 1cm^2$		150				°C/W

PART NUMBER INFORMATION

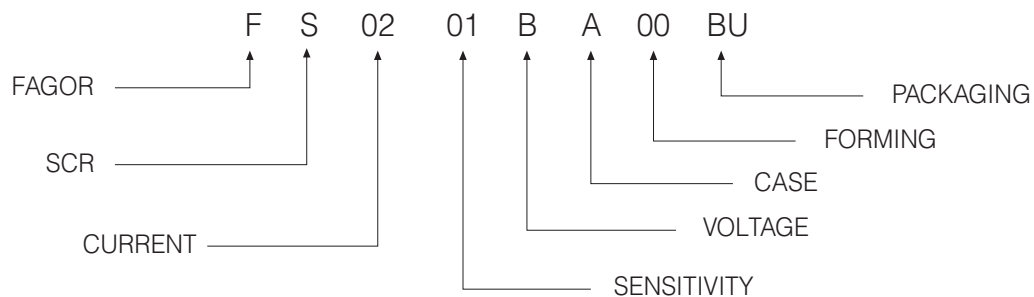

SENSITIVE GATE SCR

Fig. 1: Maximum average power dissipation versus average on-state current

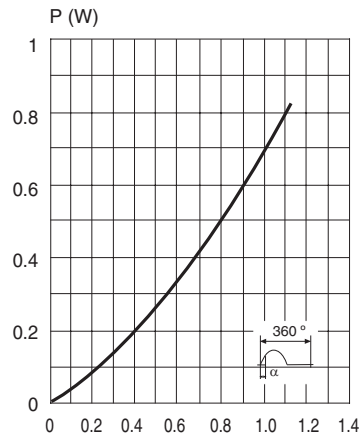

Fig. 3: Relative variation of thermal impedance junction to case versus pulse duration

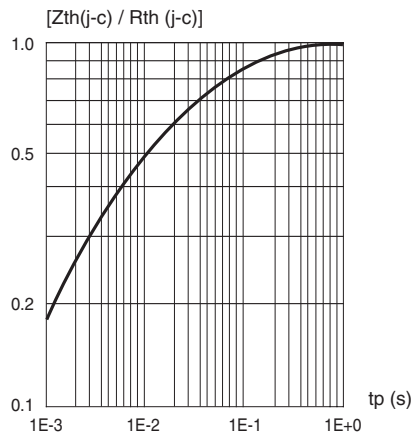

Fig. 5: Relative variation of holding current versus gate-cathode resistance (typical values).

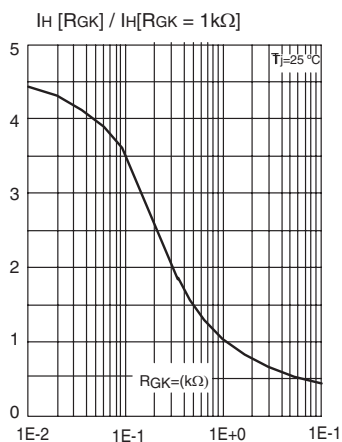

Fig. 2: Average and D.C. on-state current versus case temperature

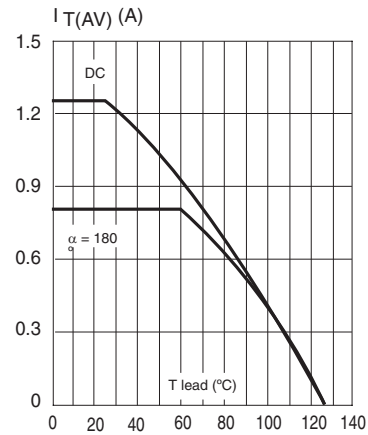

Fig. 4: Relative variation of gate trigger current, holding and latching current versus junction temperature

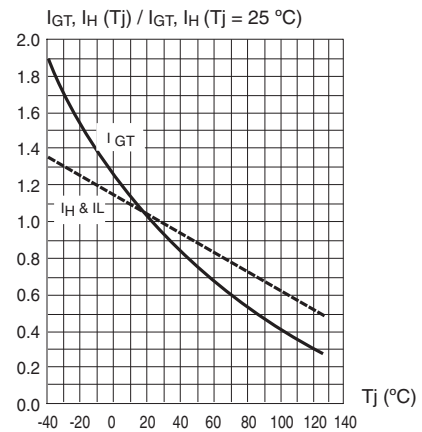
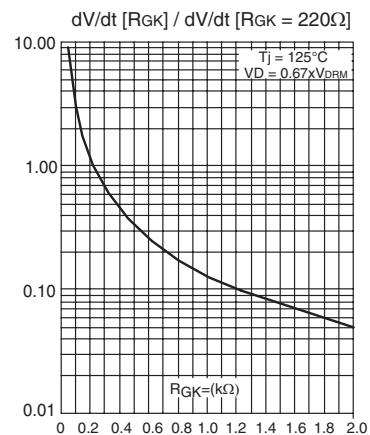

Fig. 6: Relative variation of dV/dt immunity versus gate-cathode resistance (typical values).



SENSITIVE GATE SCR

Fig. 7: Relative variation of dV/dt immunity versus gate-cathode resistance (typical values).

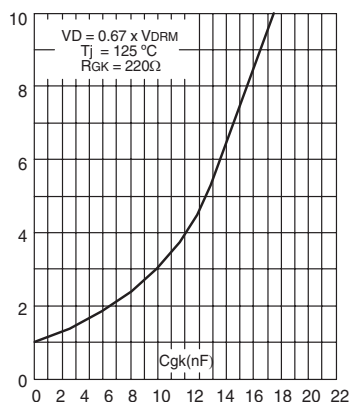

Fig. 8: Non repetitive surge peak on-state current versus number of cycles.

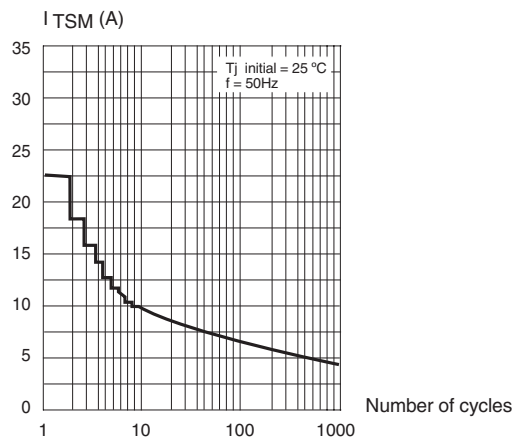

Fig. 9: Non repetitive surge peak on-state current for a sinusoidal pulse with width: $t_p < 10$ ms, and corresponding value of I^2t .

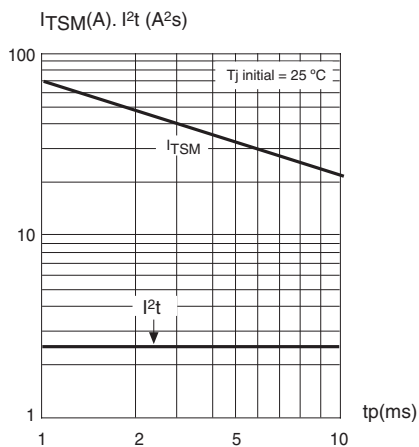
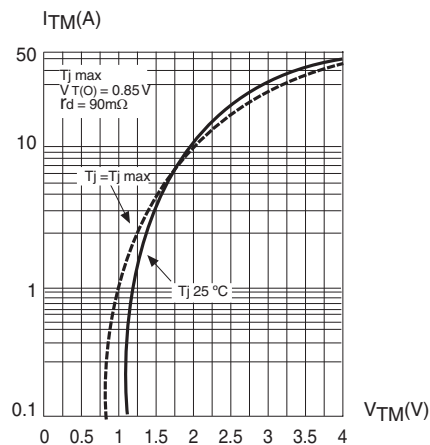

Fig. 10: On-state characteristics (maximum values)



SENSITIVE GATE SCR

PACKAGE MECHANICAL DATA

TO92

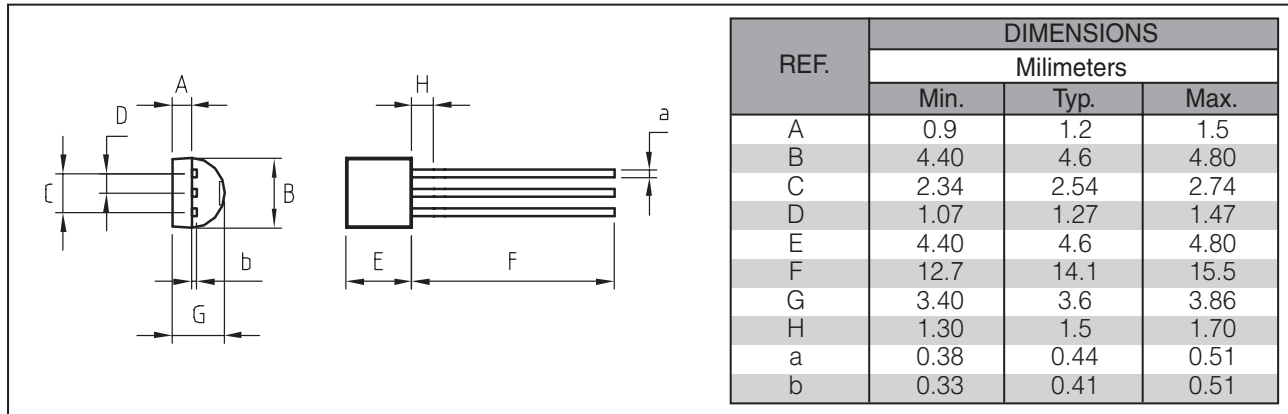

Marking: type number
Weight: 0.2 g

PACKAGE MECHANICAL DATA

TO92 (FORTAPE & REEL)

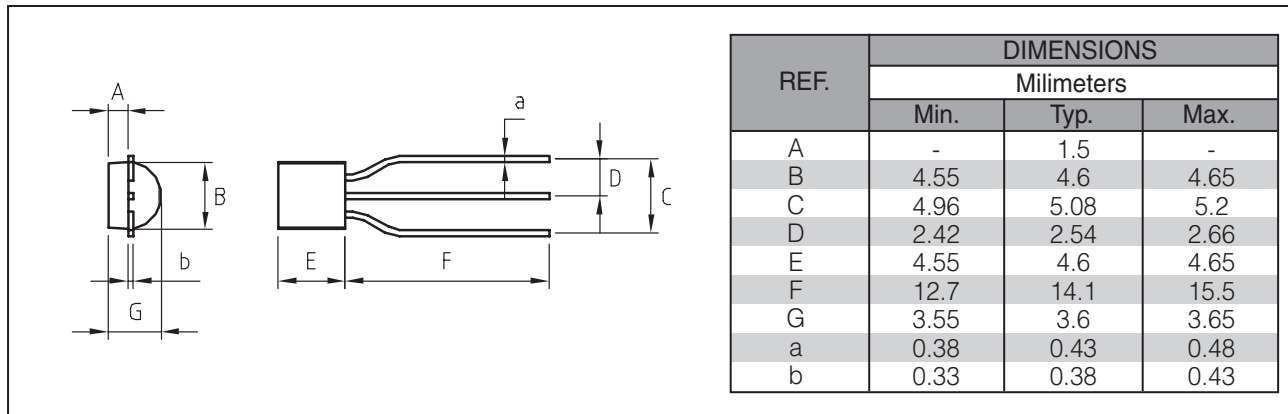

Marking: type number
Weight: 0.2 g

PACKAGE MECHANICAL DATA

RD26 (Plastic)

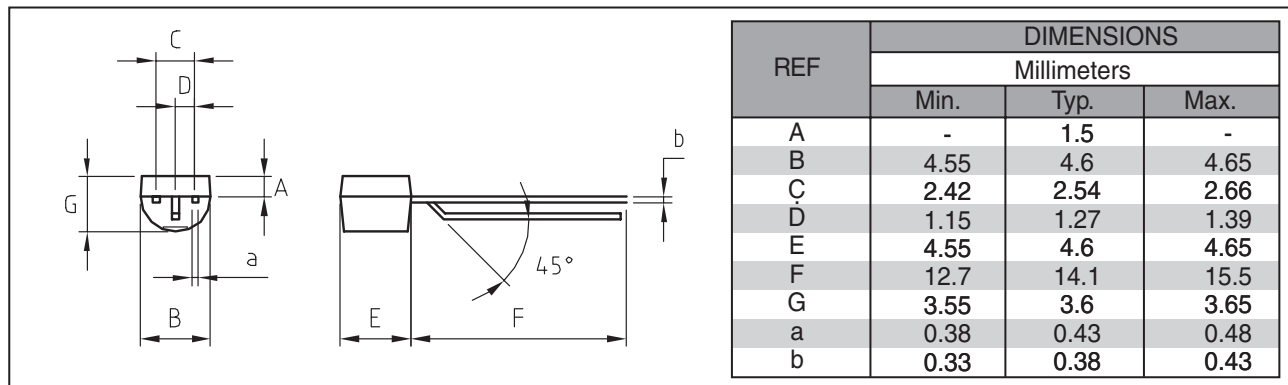

Marking: type number
Weight: 0.2 g