



FS8S0765RCB

Fairchild Power Switch(FPS)

Features

- Burst Mode Operation to Reduce the Power Consumption in the Standby Mode
- External pin for Synchronization and Soft Start
- Wide Operating Frequency Range up to 150kHz
- Low Start-up Current (Max:80uA)
- Low Operating Current (Max:15mA)
- Pulse by Pulse Current Limiting
- Over Voltage Protection (Auto Restart Mode)
- Over Load Protection (Auto Restart Mode)
- Abnormal Over Current Protection (Auto Restart Mode)
- Internal Thermal Shutdown (Auto Restart Mode)
- Under Voltage Lockout
- Internal High Voltage SenseFET

Application

- Monitor SMPS

Description

FS8S0765RCB is a Fairchild Power Switch (FPS) that is specially designed for off-line SMPS of CRT monitor with minimal external components. This device is a current mode PWM controller combined with a high voltage power SenseFET in a single package. The PWM controller features integrated oscillator to be synchronized with the external sync signal, under voltage lockout, optimized gate driver and temperature compensated precise current sources for the loop compensation. This device also includes various fault protection circuits such as over voltage protection, over load protection, abnormal over current protection and over temperature protection. Compared with discrete MOSFET and PWM controller solution, FPS can reduce total cost, component count, size and weight simultaneously increasing efficiency, productivity and system reliability. This device is well suited for the cost effective monitor power supply.



Internal Block Diagram

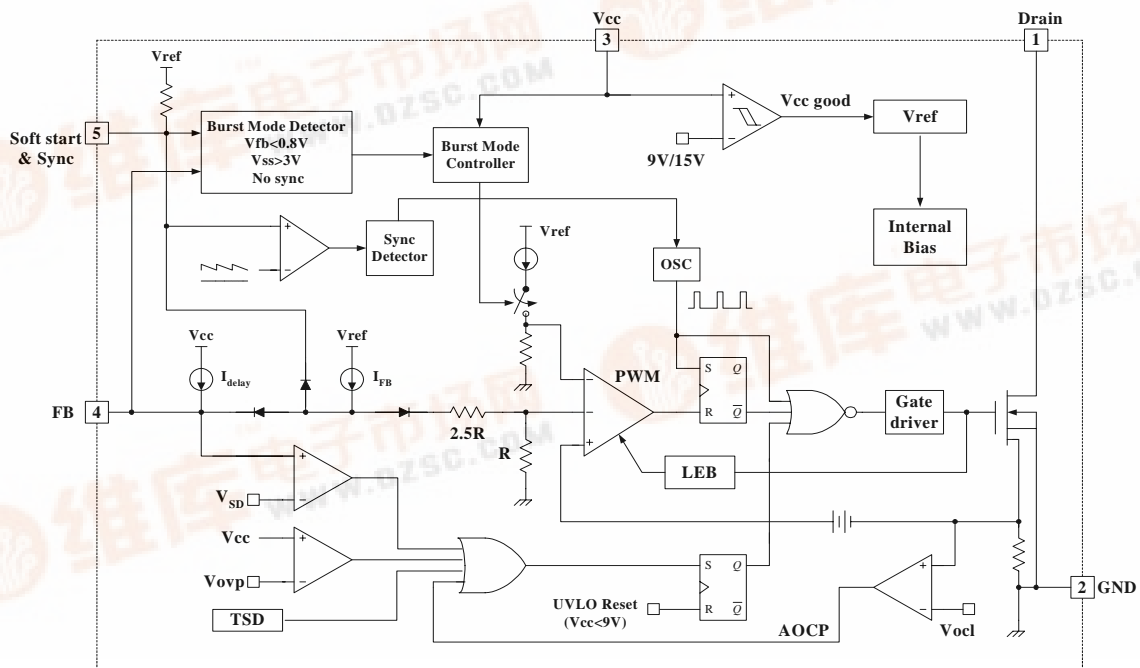

Pin Definitions

| Pin Number | Pin Name | Pin Function Description |
|------------|-------------------|--|
| 1 | Drain | High voltage power SenseFET drain connection. This pin is designed to drive the transformer directly. |
| 2 | GND | This pin is the control ground and the SenseFET source. |
| 3 | Vcc | This pin is the positive supply input. This pin provides internal operating current for both start-up and steady-state operation. |
| 4 | Feedback | This pin is internally connected to the inverting input of the PWM comparator. For stable operation, a capacitor should be placed between this pin and GND. If the voltage of this pin reaches 7.5V, the over load protection is activated resulting in shutdown of FPS. |
| 5 | Soft Start & Sync | This pin is for soft start and synchronization to the external sync signal. |

Absolute Maximum Ratings

(Ta=25°C, unless otherwise specified)

| Parameter | Symbol | Value | Unit |
|--|--------------|-------------|------|
| Drain-Gate Voltage (RGS=1MΩ) | VDGR | 650 | V |
| Gate-Source (GND) Voltage | VGS | ±30 | V |
| Drain Current Pulsed ⁽²⁾ | IDM | 28 | ADC |
| Single Pulsed Avalanche Energy ⁽³⁾ | EAS | 370 | mJ |
| Single Pulsed Avalanche Current ⁽⁴⁾ | IAS | 17 | A |
| Continuous Drain Current (Tc = 25°C) | ID | 7 | ADC |
| Continuous Drain Current (TC=100°C) | ID | 4.5 | ADC |
| Supply Voltage | VCC | 35 | V |
| Input Voltage Range | VFB | -0.3 to Vcc | V |
| | VS_S | -0.3 to 10 | V |
| Total Power Dissipation | PD(Watt H/S) | 145 | W |
| | Derating | 1.16 | W/°C |
| Operating Junction Temperature | Tj | +150 | °C |
| Operating Ambient Temperature | TA | -25 to +85 | °C |
| Storage Temperature Range | TSTG | -55 to +150 | °C |

Notes:

1. Tj=25°C to 150°C
2. Repetitive rating: Pulse width limited by maximum junction temperature
3. L=14mH, starting Tj=25°C
4. L=13uH, starting Tj=25°C

Electrical Characteristics (SenseFET part)

(Ta=25°C unless otherwise specified)

| Parameter | Symbol | Condition | Min. | Typ. | Max. | Unit |
|--|---------|--|------|------|------|------|
| Drain Source Breakdown Voltage | BVDSS | VGS=0V, ID=250μA | 650 | - | - | V |
| Zero Gate Voltage Drain Current | IDSS | VDS=650V, VGS=0V | - | - | 200 | μA |
| | | VDS=520V VGS=0V, TC=125°C | - | - | 300 | μA |
| Static Drain Source On Resistance ⁽¹⁾ | RDS(ON) | VGS=10V, ID=3.5A | - | 1.4 | 1.6 | Ω |
| Forward Transconductance | gfs | VDS=40V, ID=3.5A | - | 8 | - | mho |
| Input Capacitance | Ciss | VGS=0V, VDS=25V, f = 1MHz | - | 1415 | - | pF |
| Output Capacitance | Coss | | - | 100 | - | |
| Reverse Transfer Capacitance | Crss | | - | 15 | - | |
| Turn On Delay Time | td(on) | VDD=325V, ID=6.5A (MOSFET switching time is essentially independent of operating temperature) | - | 25 | - | nS |
| Rise Time | tr | | - | 60 | - | |
| Turn Off Delay Time | td(off) | | - | 115 | - | |
| Fall Time | tf | | - | 65 | - | |
| Total Gate Charge (Gate-Source+Gate-Drain) | Qg | VGS=10V, ID=6.5A, VDS=325V (MOSFET switching time is essentially independent of operating temperature) | - | 40 | - | nC |
| Gate-Source Charge | Qgs | | - | 7 | - | |
| Gate-Drain (Miller) Charge | Qgd | | - | 12 | - | |

Note:

(1) Pulse test : Pulse width ≤ 300μS, duty 2%

Electrical Characteristics (Continued)

(Ta=25°C unless otherwise specified)

| Parameter | Symbol | Condition | Min. | Typ. | Max. | Unit |
|-------------------------------------|---------|-------------------|------|------|------|------|
| UVLO SECTION | | | | | | |
| Start Threshold Voltage | VSTART | VFB=GND | 14 | 15 | 16 | V |
| Stop Threshold Voltage | VSTOP | VFB=GND | 8 | 9 | 10 | V |
| OSCILLATOR SECTION | | | | | | |
| Initial Frequency | FOSC | - | 18 | 20 | 22 | kHz |
| Voltage Stability | FSTABLE | 12V ≤ Vcc ≤ 23V | 0 | 1 | 3 | % |
| Temperature Stability (1) | ΔFOSC | -25°C ≤ Ta ≤ 85°C | 0 | ±5 | ±10 | % |
| Maximum Duty Cycle | DMAX | - | 92 | 95 | 98 | % |
| Minimum Duty Cycle | DMIN | - | - | - | 0 | % |
| FEEDBACK SECTION | | | | | | |
| Feedback Source Current | IFBSO | VFB=GND | 0.7 | 0.9 | 1.1 | mA |
| Feedback Sink Current | IFBSI | VFB=4V, VCC=19V | 2.4 | 3.0 | 3.6 | mA |
| Shutdown Feedback Voltage | VSD | Vfb ≥ 6.9V | 6.9 | 7.5 | 8.1 | V |
| Shutdown Delay Current | Idelay | VFB=5V | 1.6 | 2.0 | 2.4 | μA |
| PROTECTION SECTION | | | | | | |
| Over Voltage Protection | VOVP | Vcc ≥ 27V | 34 | 37 | - | V |
| Over Current Latch Voltage (2) | VOCL | - | 0.95 | 1.0 | 1.05 | V |
| Thermal Shutdown Temp.(1) | TSD | - | 140 | 160 | - | °C |
| SYNC & SOFTSTART SECTION | | | | | | |
| Softstart Voltage | VSS | Vfb=2 | 4.7 | 5.0 | 5.3 | V |
| Softstart Current | ISS | Vss=0V | 0.8 | 1.0 | 1.2 | mA |
| Sync High Threshold Voltage | VSH | Vcc=16V, Vfb=5V | 6.7 | 7.2 | 7.9 | V |
| Sync Low Threshold Voltage | VSL | Vcc=16V, Vfb=5V | 5.4 | 5.8 | 6.2 | V |

Note:

1. These parameters, although guaranteed at the design, are not tested in mass production.
2. These parameters, although guaranteed, are tested in EDS(wafer test) process.

Electrical Characteristics(Continued)

| Parameter | Symbol | Condition | Min. | Typ. | Max. | Unit |
|--|----------------------|---|------|------|------|------|
| BURST MODESECTION(DPMS MODE) | | | | | | |
| Burst Mode High Threshold Voltage | VBUH | Vfb=0V | 11.6 | 12 | 12.6 | V |
| Burst Mode Low Threshold Voltage | VBUL | Vfb=0V | 10.6 | 11 | 11.6 | V |
| Burst Mode Enable FB Voltage | VBUFB | Vcc=10.5V | 0.9 | 1.0 | 1.1 | V |
| Burst Mode Enable S_S Voltage | VBUSS | Vcc=10.5V,Vfb=0V | 2.5 | 3.0 | 3.5 | V |
| Burst Mode Enable Delay Time | TBU DT | Vcc=10.5V,Vfb=0V | - | 0.5 | - | ms |
| Burst Mode Frequency | FBU | Vcc=10.5V,Vfb=0V | 32 | 40 | 48 | kHz |
| CURRENT LIMIT(SELF-PROTECTION)SECTION | | | | | | |
| Peak Current Limit(1) | I _{OVER} | - | 3.52 | 4.0 | 4.48 | A |
| Burst Mode Peak Current Limit | I _{BU_PK} | - | 0.45 | 0.6 | 0.75 | A |
| TOTAL DEVICE SECTION | | | | | | |
| Start Up Current | I _{START} | V _{CC} =V _{start} -0.1V | - | 40 | 80 | uA |
| Operating Supply Current (2) | I _{OP} | Vfb=GND, V _{CC} =16V | - | 9 | 15 | mA |
| | I _{OP(MIN)} | Vfb=GND, V _{CC} =12V | | | | |
| | I _{OP(MAX)} | Vfb=GND, V _{CC} =27V | | | | |

Note:

1. These parameters indicate inductor current.
2. These parameters are the current flowing in the control IC.

Typical Performance Characteristics

(These characteristic graphs are normalized at Ta= 25°C)

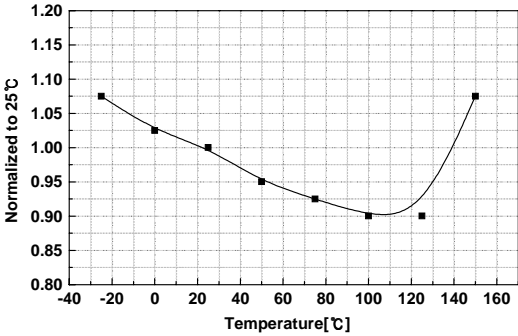

Figure 1. Start Up Current vs. Temp.

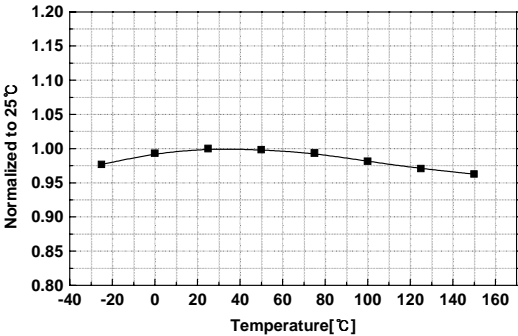

Figure 2. Operating Supply Current vs. Temp.

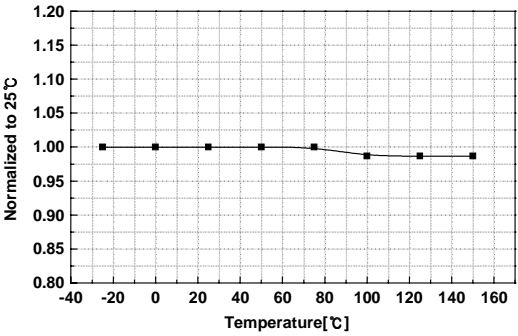

Figure 3. Start Threshold Voltage vs. Temp.

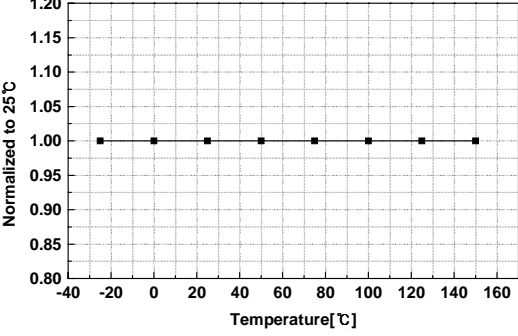

Figure 4. Stop Threshold Voltage vs. Temp.

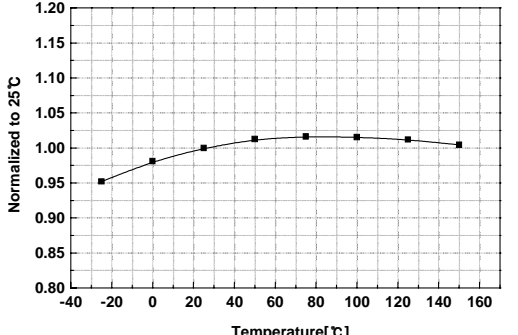

Figure 5. Initial Frequency vs. Temp.

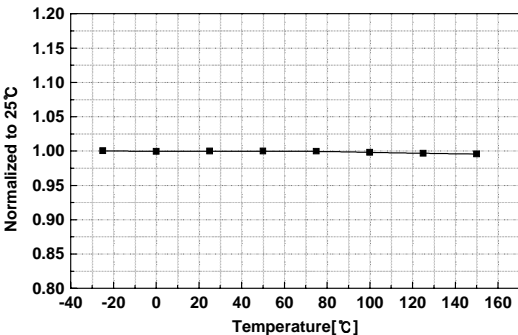

Figure 6. Maximum Duty Cycle vs. Temp.

Typical Performance Characteristics(Continued)

(These characteristic graphs are normalized at Ta= 25°C)

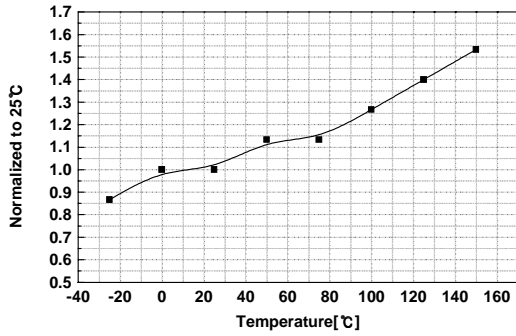

Figure 7. Feedback Offset Voltage vs. Temp.

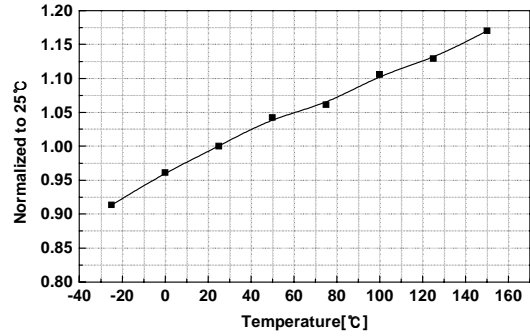

Figure 8. Feedback Sink Current vs. Temp.

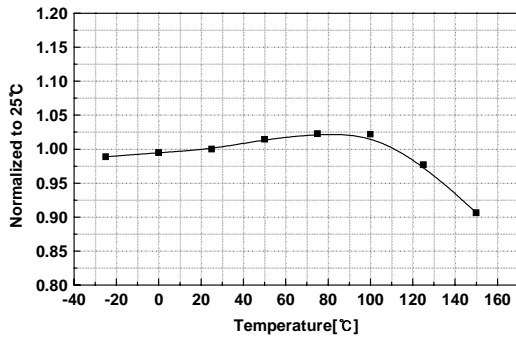

Figure 9. Shutdown Delay Current vs. Temp.

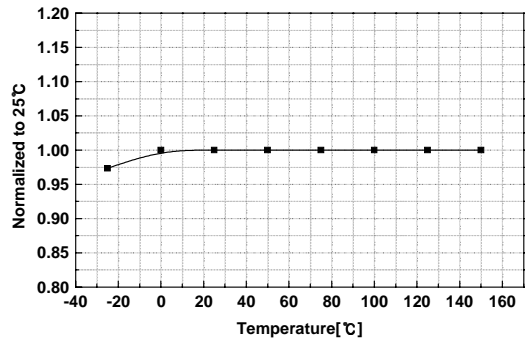

Figure 10. Shutdown Feedback Voltage vs. Temp.

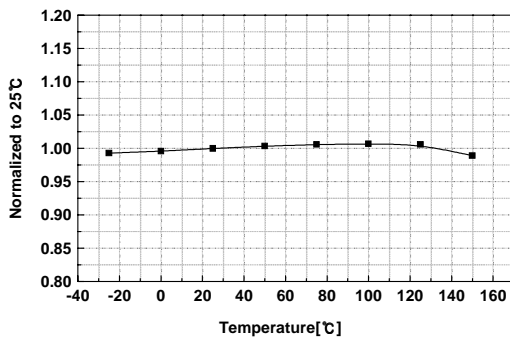

Figure 11. Soft Start Voltage vs. Temp.

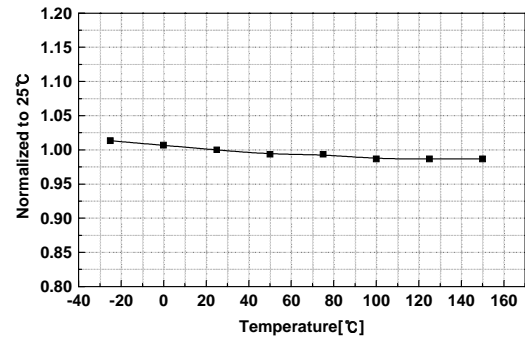

Figure 12. Over Voltage Protection vs. Temp.

Typical Performance Characteristics(Continued)

(These characteristic graphs are normalized at Ta= 25°C)

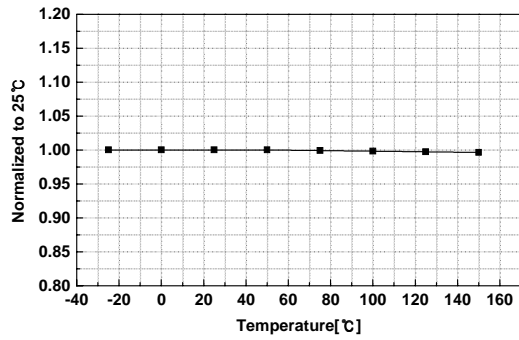

Figure 13. Normal Mode Regulation Voltage vs. Temp.

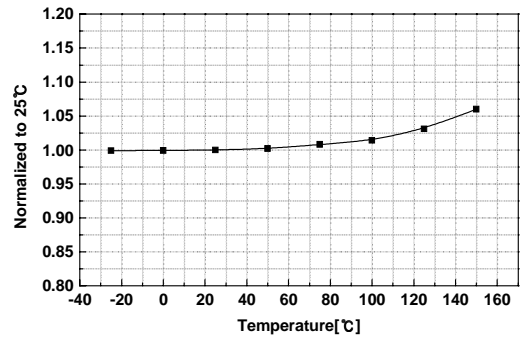

Figure 14. Peak Current vs. Temp.

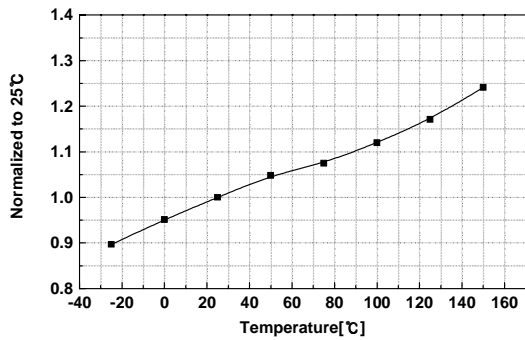

Figure 15. Feedback Sink Current vs. Temp.

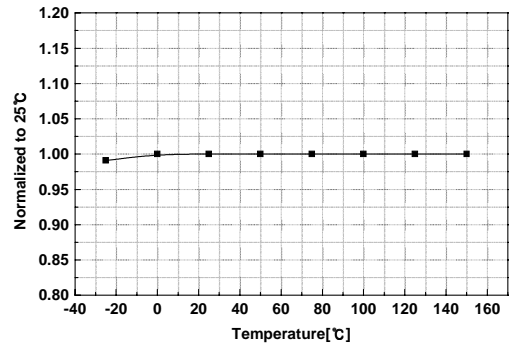

Figure 16. Burst Mode Low Threshold Voltage vs. Temp.

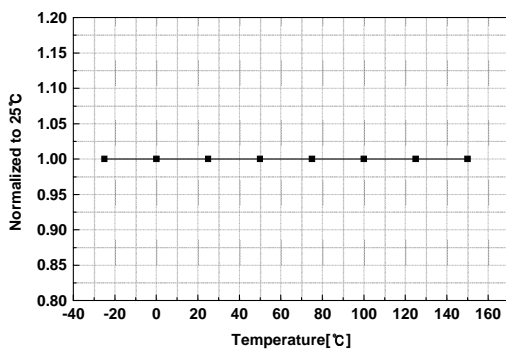

Figure 17. Burst Mode High Threshold Voltage vs. Temp.

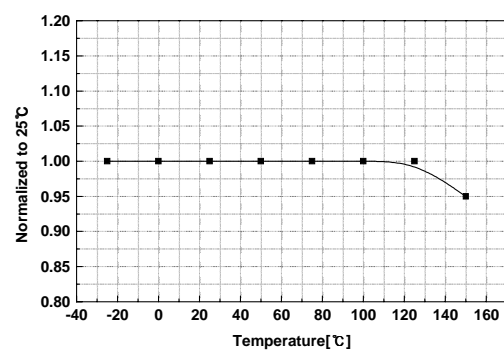

Figure 18. Burst Mode Enable Voltage vs. Temp.

Typical Performance Characteristics(Continued)

(These characteristic graphs are normalized at Ta= 25°C)

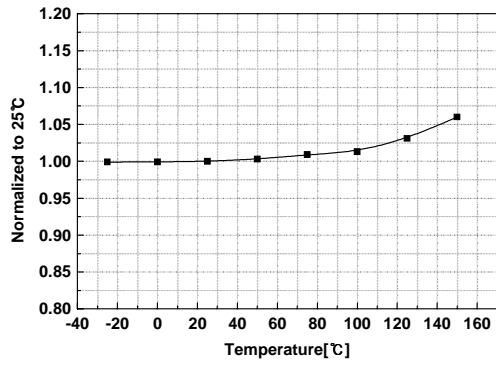

Figure 19. Burst Mode Peak Current vs. Temp.

Functional Description

1. Start up : To guarantee stable operation of the control IC, FS8S0765RCB has UVLO circuit with 6V hysteresis band. Figure 1 shows the relation between the supply current (I_{cc}) and the supply voltage (V_{cc}). Before V_{cc} reaches 15V, the FPS consumes only startup current of 80 μ A, which is usually provided by the DC link through start-up resistor. When V_{cc} reaches 15V, the FPS begins operation and the operating current increases to 15mA as shown. Once the control IC starts operation, it continues its normal operation until V_{cc} goes below the stop voltage of 9V

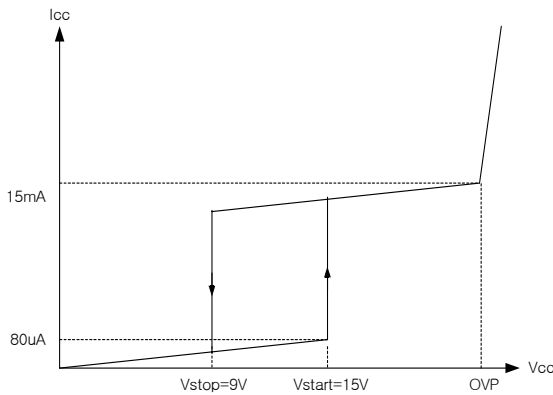

Figure 1. Start up with hysteresis

2. Feedback Control : FS8S0765RCB employs primary side regulation, which permits elimination of feedback circuit components in the secondary side such as opto coupler and TL431. Figure 2 shows the primary side control circuit. The primary side regulation voltage (V_{psr}) is controlled to the breakdown voltage of zener diode (D_z). Because current mode control is employed, the drain current of the power MOSFET is limited by the inverting input of PWM comparator (V_{fb}^*). When MOSFET turns on, usually there exists high current spike in the MOSFET current caused by primary-side capacitance and secondary-side rectifier reverse recovery. In order to prevent premature termination of the switching pulse due to the current spike, the FPS employs leading edge blanking (LEB). The leading edge blanking circuit inhibits the PWM comparator for a short time after the MOSFET is turned on.

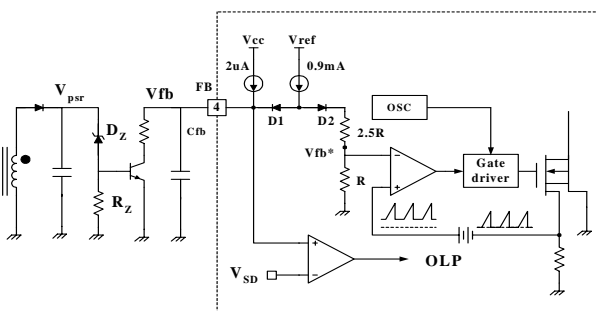

Figure 2. Primary side control circuit

3. Protection function : FS8S0765RCB has 4 self protective functions such as abnormal over current protection (AOCP), over load protection (OLP), over voltage protection (OVP) and thermal shutdown (TSD). Because these protection circuits are fully integrated into the IC without external components, the reliability can be improved without cost increase. In the event of these fault conditions, the FPS enters into auto-restart operation. Once the fault condition occurs, switching operation is terminated and MOSFET remains off, which forces V_{cc} to be reduced. When V_{cc} reaches 9V, the protection is reset and the supply current reduces to 80 uA. Then, V_{cc} begin to increase with the current provided through the start-up resistor. When V_{cc} reaches 15V, the FPS resumes its normal operation if the fault condition is removed. In this manner, the auto-restart alternately enables and disables the switching of the power MOSFET until the fault condition is eliminated as illustrated in figure 3.

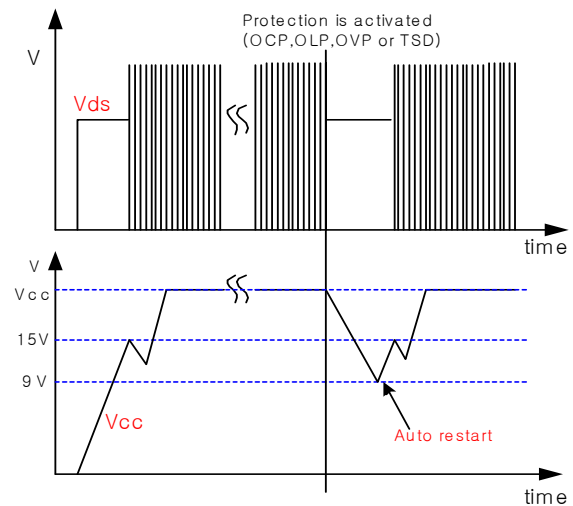

Figure 3. Auto restart operation after protection

3.1 Abnormal Over Current Protection (AOCP) : When the secondary rectifying diodes or the transformer pins are shorted, a steep current with extremely high di/dt can flow during the LEB time. Therefore, the abnormal over current protection (AOCP) block is added to ensure the reliability as shown in figure 4. It turns off the SenseFET within 300ns after the abnormal over current condition is sensed.

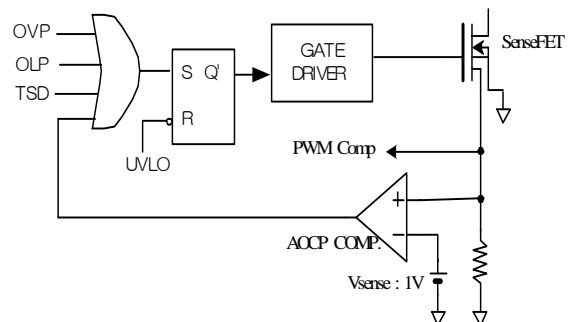

Figure 4. AOCP block

3.2 Over Load Protection (OLP) : When the load current exceeds a pre-set level for longer than pre-determined time, protection circuit should be activated in order to protect the SMPS. Because of the pulse-by-pulse current limit capability, the maximum peak current through the SMPS is limited, and therefore the maximum input power is restricted with a given input voltage. If the output consumes beyond this maximum power, the output voltage together with primary side regulation voltage decrease below the set voltage. This reduces the current through primary side regulation transistor, which increases feedback voltage (Vfb). If Vfb exceeds 2.7V, D1 is blocked and the 2uA current source starts to charge Cfb slowly compared to when the 0.9mA current source charges Cfb. In this condition, Vfb continues increasing until it reaches 7.5V, and the switching operation is terminated at that time as shown in figure 6. The delay time for shutdown is the time required to charge Cfb from 2.7V to 7.5V with 2uA.

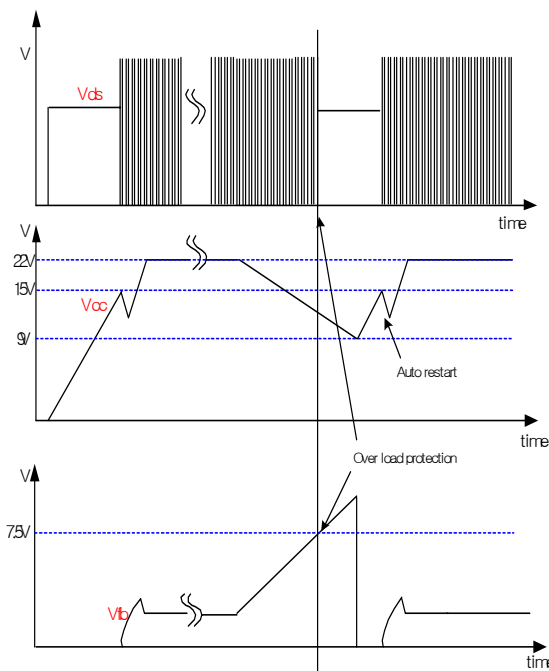

Figure 5. The waveforms at the OLP and auto restart

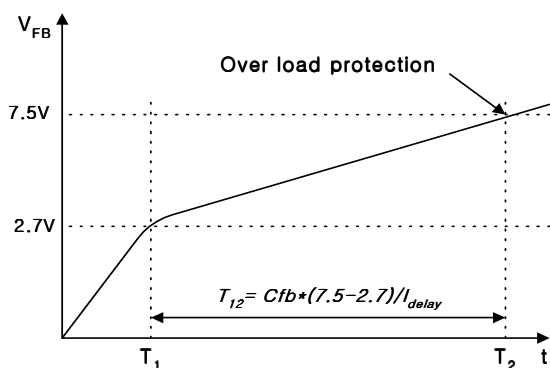

Figure 6. Over load protection

3.3 Over Voltage Protection (OVP) : In case of malfunction in the primary side feedback circuit, or feedback loop open caused by a defect of solder, the current through primary side control transistor becomes almost zero. Then, Vfb climbs up in a similar manner to the over load situation, forcing the preset maximum current to be supplied to the secondary side until the over load protection is activated. Because energy more than required is provided to the output, the output voltage may exceed the rated voltage before the over load protection is activated, resulting in the breakdown of the devices in the secondary side. In order to prevent this situation, an over voltage protection (OVP) circuit is employed. When the Vcc voltage touches 37V, the OVP block is activated.

3.4 Thermal Shutdown (TSD) : The SenseFET and the control IC are built in one package. This makes it easy for the control IC to detect the heat generation from the SenseFET. When the temperature exceeds approximately 160°C, the thermal shutdown is activated.

4. Soft Start : Figure 7 shows the soft start circuit. During the initial start up, the 0.9 mA current source leaks out through C_{SS} and R_{SS}. As C_{SS} is charged, the leakage current decreases. Therefore, by choosing much bigger C_{SS} than C_{fb}, it is possible to increase the feedback voltage slowly forcing the SenseFET current to increase slowly. After C_{SS} reaches its steady state value, D3 is blocked and the soft switching circuit is decoupled from the feedback circuit. If the value of C_{SS} is too large, there is possibility that Vfb increases to 7.5V activating the over load protection during soft start time. In order to avoid this situation, it is recommended that the value of C_{SS} should not exceed 100 times of C_{fb}.

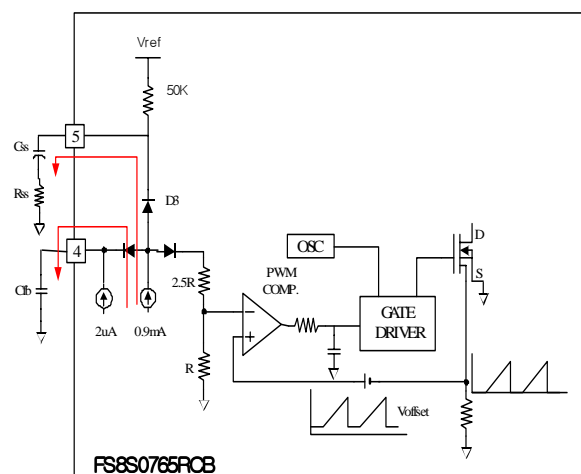

Figure 7. The circuit for the soft start

5. Synchronization : In order to reduce the effect of switching noise on the screen, the SMPS for monitor synchronizes its switching frequency to an external signal, typically the horizontal sync flyback signal. The switching frequency of the FPS can vary from 20 kHz to 150 kHz according to the

external sync signal. The internal sync comparator detects the sync signal and determines the SenseFET turn-on time. The SenseFET is turned on at the negative edge of the sync comparator output. The reference voltage of the sync comparator is an inverted saw tooth with a base frequency of 20kHz and a varying range between 5.8V and 7.2V, as shown in the figure 8. The inverted saw tooth reference gets rid of the excessive switching noise at the first synchronized turn-on. The external sync signal is recommended to have an amplitude higher than 4.2V.

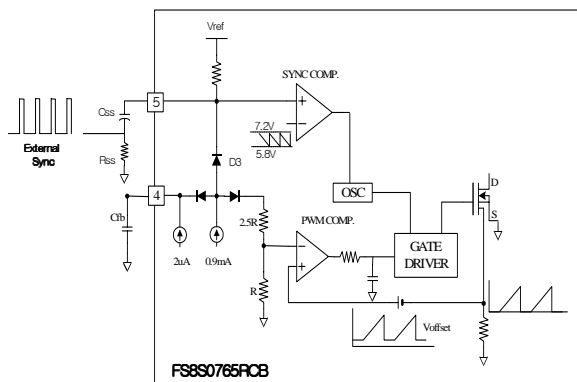

Figure 8. The circuit for the synchronization with external sync

6. Burst mode operation : In order to minimize the power dissipation at standby mode, FS8S0765RCB has a burst mode operation. In burst mode, the FPS reduces the effective switching frequency and output voltage. The FPS enters into burst mode when the voltage of the soft start pin is higher than 3V, no sync signal is applied and the feedback voltage is lower than 1V. During the burst mode operation, V_{cc} is hysteresis controlled between 11V and 12V. Once the FPS enters into burst mode, it stops switching operation until V_{cc} drops to 11V. When V_{cc} reaches 11V, the FPS starts switching with switching frequency of 40kHz and peak MOSFET current of 0.6 A until V_{cc} reaches 12V. When V_{cc} reaches 12V, the switching operation is terminated again until V_{cc} reduces to 11V. Figure 9 shows operating waveforms. The soft start during the initial start-up is shown in the section 1. During this period, there is no external sync signal and the switching frequency is 20kHz. The section 2 represents the normal mode operation. The switching frequency is synchronized with the external sync signal. In the section 3, the external sync signal is removed. However, the load still exists and thus the feedback voltage (V_{fb}) is higher than 1V. In this period, the FPS does the normal switching operation with switching frequency of 20kHz. The section 4 and 5 show the burst mode operation. At the end of the section 3, the load is eliminated and the feedback voltage (V_{fb}) drops below 1V forcing the FPS to stop switching operation. During the section 4, V_{cc} goes down to 11V. During section 5, V_{cc} is hysteresis controlled between 11V and 12V. When the external sync signal is applied on the pin 5, the FPS resumes its normal operation. In order to minimize the power con-

sumption in standby mode, it is recommended to set the value of V_{cc} during normal operation as high as possible (about 29V).

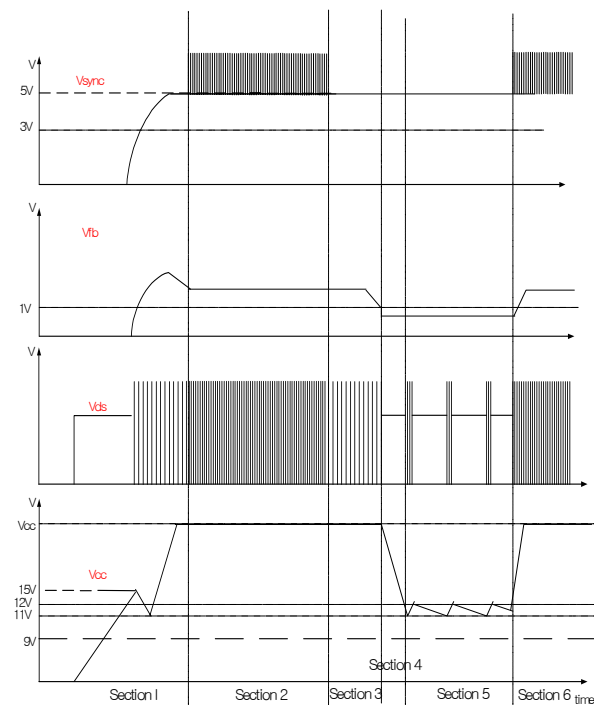
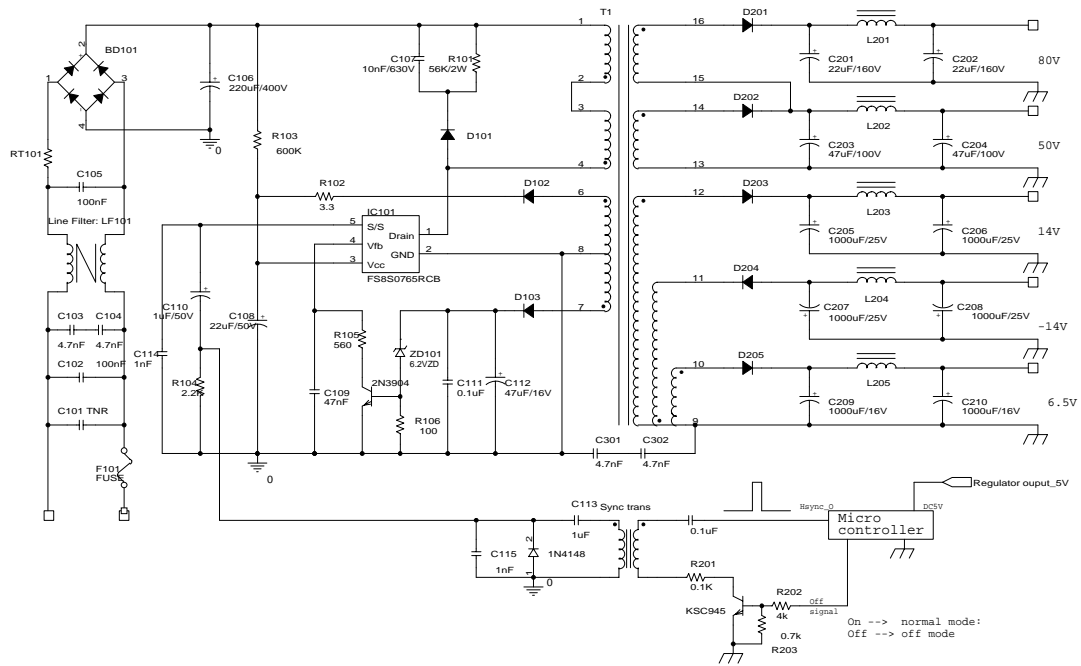

Figure 9. The operation of the FS8S0765RCB at the normal mode and the off mode

Typical application circuit

1. 80W Universal Input Power Supply For CRT Monitor



2. Transformer Schematic Diagram

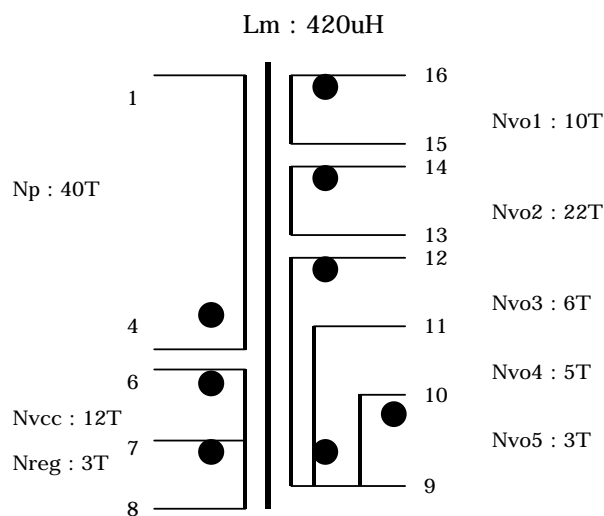

3.Winding Specification

| No | Pin (s→f) | Wire | Turns | Winding Method |
|---|-----------|----------------------|-------|------------------|
| Np1 | 4 → 1 | 0.3 ^φ × 1 | 40 | Solenoid Winding |
| Insulation: Polyester Tape t = 0.050mm, 2Layers | | | | |
| Nvo1 | 16 → 15 | 0.3 ^φ × 1 | 10 | Center Winding |
| Insulation: Polyester Tape t = 0.050mm, 2Layers | | | | |
| Nreg | 7 → 8 | 0.2 ^φ × 1 | 3 | Solenoid Winding |
| Insulation: Polyester Tape t = 0.050mm, 2Layers | | | | |
| Nvo2 | 14 → 13 | 0.3 ^φ × 3 | 22 | Center Winding |
| Insulation: Polyester Tape t = 0.050mm, 2Layers | | | | |
| Np2 | 4 → 1 | 0.3 ^φ × 1 | 40 | Solenoid Winding |
| Insulation: Polyester Tape t = 0.050mm, 2Layers | | | | |
| Nvo3 | 12 → 9 | 0.3 ^φ × 2 | 6 | Solenoid Winding |
| Insulation: Polyester Tape t = 0.050mm, 2Layers | | | | |
| Nvo4 | 9 → 11 | 0.3 ^φ × 1 | 5 | Solenoid Winding |
| Insulation: Polyester Tape t = 0.050mm, 2Layers | | | | |
| Nvo5 | 10 → 9 | 0.3 ^φ × 2 | 3 | Solenoid Winding |
| Insulation: Polyester Tape t = 0.050mm, 2Layers | | | | |
| Nvcc | 6 → 8 | 0.2 ^φ × 1 | 12 | Solenoid Winding |
| Outer Insulation: Polyester Tape t = 0.050mm, 2Layers | | | | |

4.Electrical Charateristics

| | Pin | Specification | Remarks |
|--------------------|-------|---------------|---------------------------|
| Inductance | 1 - 4 | 420uH ± 10% | 300kHz, 1V |
| Leakage Inductance | 1 - 4 | 5uH Max | 2 nd all short |

5. Core & Bobbin

Core : EER 3540
 Bobbin : EER3540
 Ae(mm²) : 107

6.Demo Circuit Part List

| Part | Value | Note | Part | Value | Note |
|------------------|------------|------------------------|--------------------|------------|------------------------|
| Fuse | | | C201 | 22nF/160V | Electorlytic Capacitor |
| F101 | 3A/250V | - | C202 | 22nF/160V | Electorlytic Capacitor |
| NTC | | | C203 | 47nF/100V | Electorlytic Capacitor |
| RT101 | 10D-9 | - | C204 | 47nF/100V | Electorlytic Capacitor |
| Resistor | | | C205 | 1000nF/25V | Electorlytic Capacitor |
| R101 | 56K | 2W | C206 | 1000nF/25V | Electorlytic Capacitor |
| R102 | 3.3 | 1/4W | C207 | 1000nF/25V | Electorlytic Capacitor |
| R103 | 600K | 1W | C208 | 1000nF/25V | Electorlytic Capacitor |
| R104 | 2.2K | 1/4W | C209 | 1000nF/25V | Electorlytic Capacitor |
| R105 | 0.56K | 1/4W | C210 | 1000nF/25V | Electorlytic Capacitor |
| R106 | 0.1K | 1/4W | C211 | 0.1uF/50V | Ceramic Capacitor |
| R201 | 0.1K | 1/4W | C301 | 4.7nF | AC Filter Capacitor |
| R202 | 4K | 1/4W | C302 | 4.7nF | AC Filter Capacitor |
| R203 | 0.7K | 1/4W | | | |
| | | | Sync trans | 22mH | |
| | | | | | |
| Inductor | | | | | |
| L201 ~ L205 | 13uH | | | | |
| | | | Diode | | |
| | | | D101 | UF4007 | |
| Capacitor | | | D102 | TVR10G | |
| C101 | 471D10 | TNR | D103 | TVR10G | |
| C102 | 100nF | Box Capacitor | D201 | UF4007 | |
| C103 | 4.7nF | AC Filter Capacitor | D202 | UF5404 | |
| C104 | 4.7nF | AC Filter Capacitor | D203 | UF5402 | |
| C105 | 100nF | Box Capacitor | D204 | UF5402 | |
| C106 | 220uF/400V | Electorlytic Capacitor | D205 | UF5401 | |
| C107 | 10nF/630V | Caramic Capacitor | | | |
| C108 | 22uF/50V | Electorlytic Capacitor | BD101 | KBL406 | Bridge Diode |
| C109 | 47nF/50V | Caramic Capacitor | Line Filter | | |
| C110 | 1uF/50V | Electorlytic Capacitor | LF101 | 24mH | |
| C111 | 0.1uF/50V | Caramic Capacitor | IC | | |
| C112 | 47uF/50V | Electorlytic Capacitor | IC101 | FS8S0765RC | (7A, 650V) |
| C113 | 1uF/50v | Electorlytic Capacitor | IC201 | KSC945 | NPN Transistor |
| C114 | 1nF/50V | Caramic Capacitor | | | |
| C115 | 1nF/50V | Caramic Capacitor | | | |
| | | | | | |
| | | | | | |
| | | | | | |

Package Dimensions

TO-220-5L

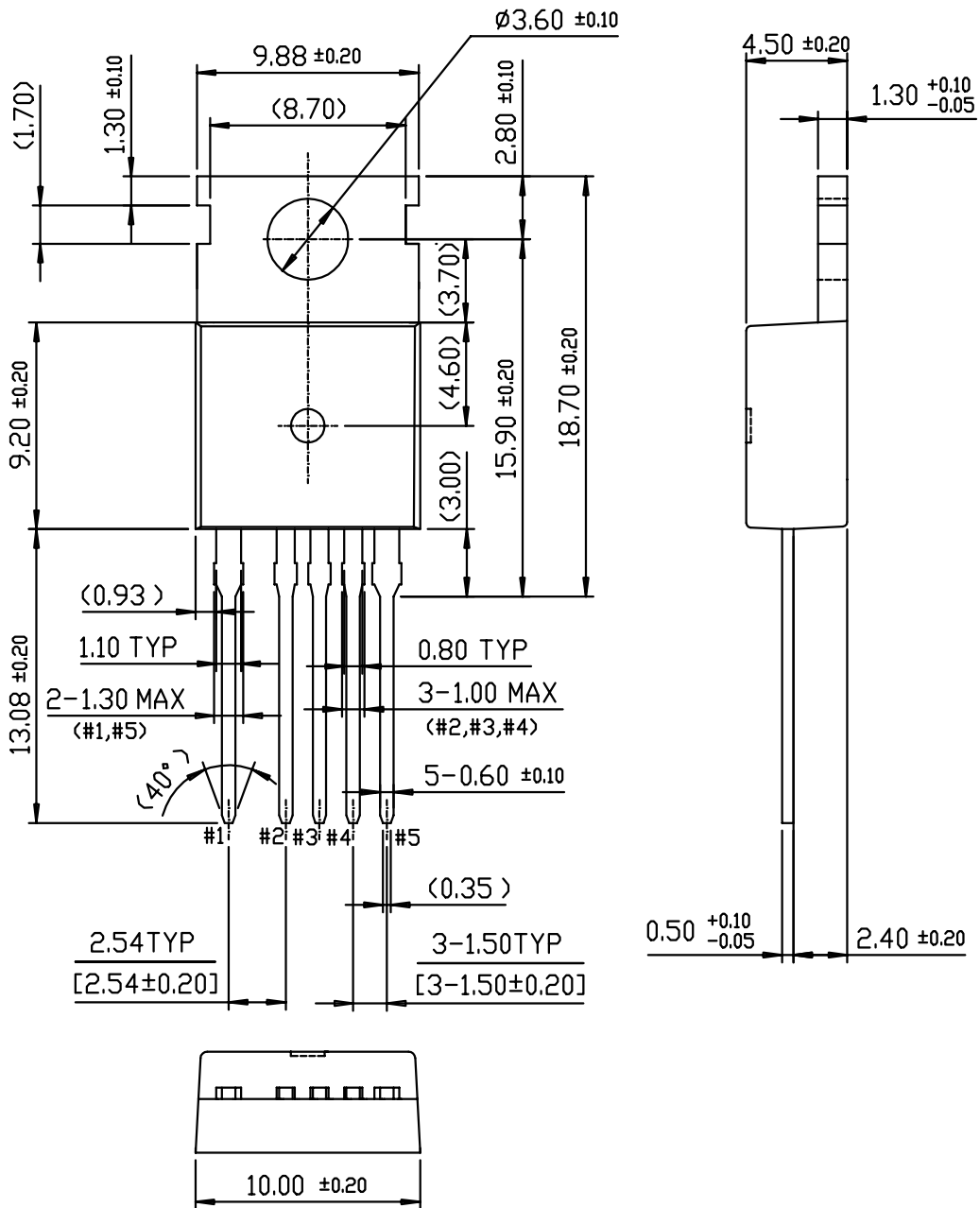

Package Dimensions (Continued)

TO-220-5L(Forming)

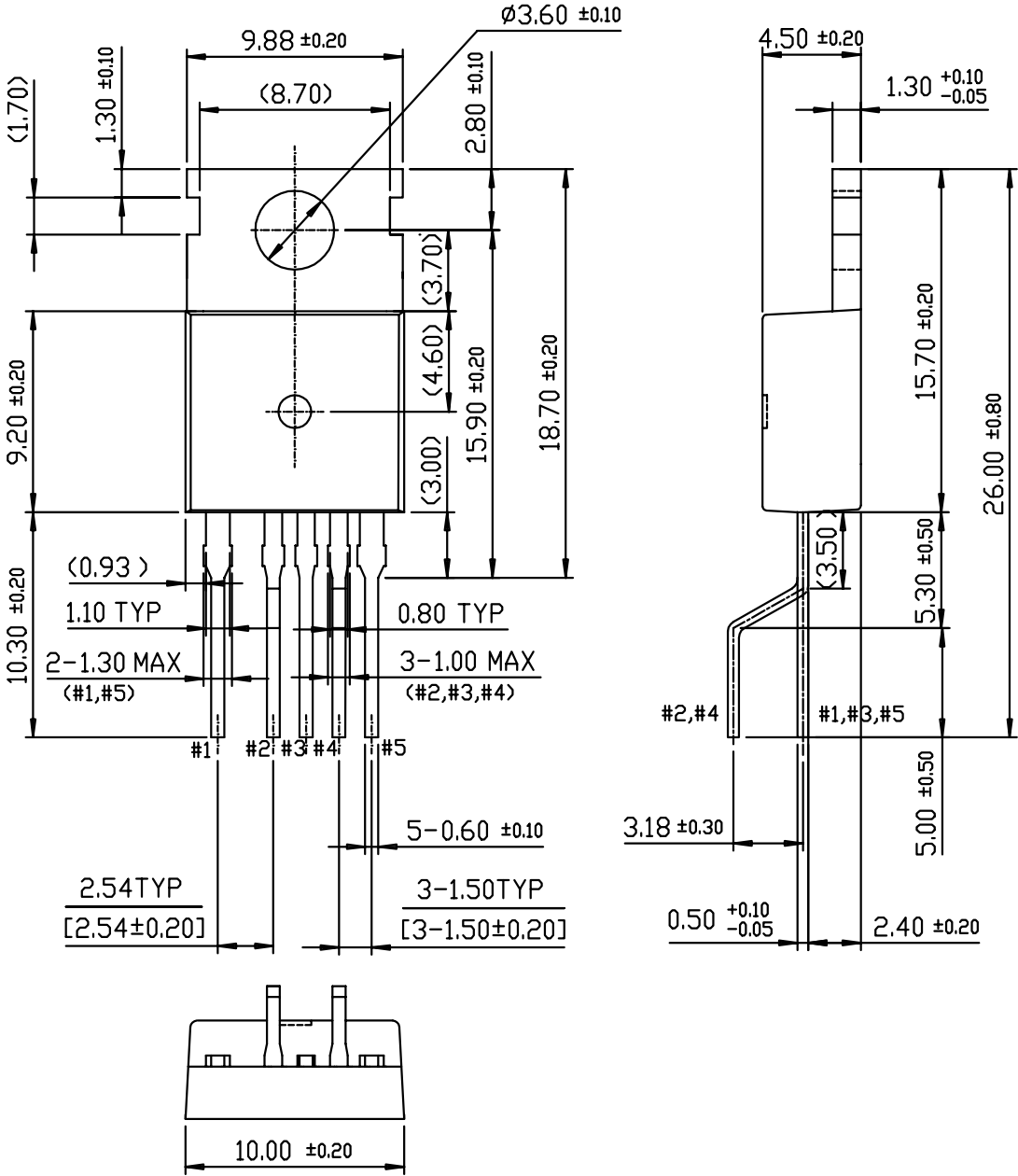

Ordering Information

| Product Number | Package | Marking Code | BVdss | Rds(on)Max. |
|-----------------|--------------------|--------------|-------|-------------|
| FS8S0765RCBTU | TO-220-5L | 8S0765RCB | 650V | 1.6 |
| FS8S0765RCBYDTU | TO-220-5L(Forming) | | | |

TU : Non Forming Type

YDTU : Forming Type

DISCLAIMER

FAIRCHILD SEMICONDUCTOR RESERVES THE RIGHT TO MAKE CHANGES WITHOUT FURTHER NOTICE TO ANY PRODUCTS HEREIN TO IMPROVE RELIABILITY, FUNCTION OR DESIGN. FAIRCHILD DOES NOT ASSUME ANY LIABILITY ARISING OUT OF THE APPLICATION OR USE OF ANY PRODUCT OR CIRCUIT DESCRIBED HEREIN; NEITHER DOES IT CONVEY ANY LICENSE UNDER ITS PATENT RIGHTS, NOR THE RIGHTS OF OTHERS.

LIFE SUPPORT POLICY

FAIRCHILD'S PRODUCTS ARE NOT AUTHORIZED FOR USE AS CRITICAL COMPONENTS IN LIFE SUPPORT DEVICES OR SYSTEMS WITHOUT THE EXPRESS WRITTEN APPROVAL OF THE PRESIDENT OF FAIRCHILD SEMICONDUCTOR CORPORATION. As used herein:

1. Life support devices or systems are devices or systems which, (a) are intended for surgical implant into the body, or (b) support or sustain life, and (c) whose failure to perform when properly used in accordance with instructions for use provided in the labeling, can be reasonably expected to result in a significant injury of the user.
2. A critical component in any component of a life support device or system whose failure to perform can be reasonably expected to cause the failure of the life support device or system, or to affect its safety or effectiveness.