

FAIRCHILD
SEMICONDUCTOR™

July 1997
Revised December 1999

FST16212 24-Bit Bus Exchange Switch

General Description

The Fairchild Switch FST16212 provides 24-bits of high-speed CMOS TTL-compatible bus switching or exchanging. The low on resistance of the switch allows inputs to be connected to outputs without adding propagation delay or generating additional ground bounce noise.

The device operates as a 24-bit bus switch or a 12-bit bus exchanger, which allows data exchange between the four signal ports via the data-select terminals.

Features

- 4Ω switch connection between two ports.
- Minimal propagation delay through the switch.
- Low I_{CC} .
- Zero bounce in flow-through mode.
- Control inputs compatible with TTL level.

Ordering Code:

| Order Number | Package Number | Package Description |
|--------------|----------------|---|
| FST16212MEA | MS56A | 56-Lead Shrink Small Outline Package (SSOP), JEDEC MO-118, 0.300 Wide |
| FST16212MTD | MTD56 | 56-Lead Thin Shrink Small Outline Package (TSSOP), JEDEC MO-153, 6.1mm Wide |

Devices also available in Tape and Reel. Specify by appending the suffix letter "X" to the ordering code.

Logic Diagram

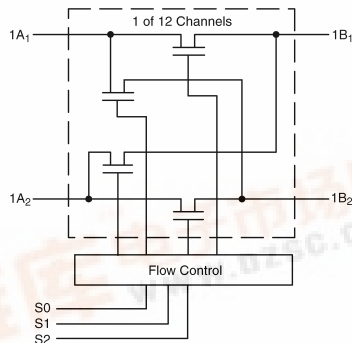

Connection Diagram

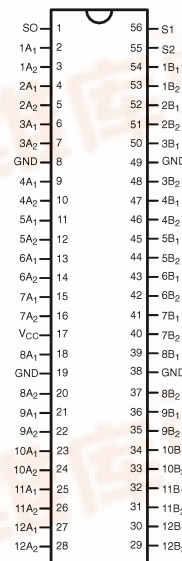

Truth Table

| S2 | S1 | S0 | A ₁ | A ₂ | Function |
|----|----|----|----------------|----------------|---|
| L | L | L | Z | Z | Disconnect |
| L | L | H | B ₁ | Z | A ₁ = B ₁ |
| L | H | L | B ₂ | Z | A ₁ = B ₂ |
| L | H | H | Z | B ₁ | A ₂ = B ₁ |
| H | L | L | Z | B ₂ | A ₂ = B ₂ |
| H | L | H | Z | Z | Disconnect |
| H | H | L | B ₁ | B ₂ | A ₁ = B ₁ , A ₂ = B ₂ |
| H | H | H | B ₂ | B ₁ | A ₁ = B ₂ , A ₂ = B ₁ |

Pin Descriptions

| Pin Name | Description |
|---------------------------------|--------------------|
| S2, S1, S0 | Data-select inputs |
| A ₁ , A ₂ | Bus A |
| B ₁ , B ₂ | Bus B |

FST16212 24-Bit Bus Exchange Switch



Absolute Maximum Ratings(Note 1)

| | |
|---|------------------|
| Supply Voltage (V_{CC}) | -0.5V to +7.0V |
| DC Switch Voltage (V_S) | -0.5V to +7.0V |
| DC Input Voltage (V_{IN}) (Note 2) | -0.5V to +7.0V |
| DC Input Diode Current (I_{IK}) $V_{IN} < 0V$ | -50mA |
| DC Output (I_{OUT}) Sink Current | 128mA |
| DC V_{CC}/GND Current (I_{CC}/I_{GND}) | +/- 100mA |
| Storage Temperature Range (T_{STG}) | -65°C to +150 °C |

Recommended Operating Conditions (Note 3)

| | |
|--|------------------|
| Power Supply Operating (V_{CC}) | 4.0V to 5.5V |
| Input Voltage (V_{IN}) | 0V to 5.5V |
| Output Voltage (V_{OUT}) | 0V to 5.5V |
| Input Rise and Fall Time (t_r, t_f) | |
| Switch Control Input | 0nS/V to 5nS/V |
| Switch I/O | 0nS/V to DC |
| Free Air Operating Temperature (T_A) | -40 °C to +85 °C |

Note 1: The "Absolute Maximum Ratings" are those values beyond which the safety of the device cannot be guaranteed. The device should not be operated at these limits. The parametric values defined in the Electrical Characteristics tables are not guaranteed at the absolute maximum rating. The "Recommended Operating Conditions" table will define the conditions for actual device operation.

Note 2: The input and output negative voltage ratings may be exceeded if the input and output diode current ratings are observed.

Note 3: Unused control inputs must be held high or low. They may not float.

DC Electrical Characteristics

| Symbol | Parameter | V_{CC} (V) | $T_A = -40\text{ °C to }+85\text{ °C}$ | | | Units | Conditions |
|-----------------|----------------------------------|-----------------|--|-----------------|-----------|----------|--|
| | | | Min | Typ (Note 4) | Max | | |
| V_{IK} | Clamp Diode Voltage | 4.5 | | | -1.2 | V | $I_{IN} = -18mA$ |
| V_{IH} | HIGH Level Input Voltage | 4.0-5.5 | 2.0 | | | V | |
| V_{IL} | LOW Level Input Voltage | 4.0-5.5 | | | 0.8 | V | |
| I_I | Input Leakage Current | 5.5 | | | ± 1.0 | μA | $0 \leq V_{IN} \leq 5.5V$ |
| | | 0 | | | 10 | μA | $V_{IN} = 5.5V$ |
| I_{OZ} | OFF-STATE Leakage Current | 5.5 | | | ± 1.0 | μA | $0 \leq A, B \leq V_{CC}$ |
| R_{ON} | Switch On Resistance (Note 5) | 4.5 | | 4 | 7 | Ω | $V_{IN} = 0V, I_{IN} = 64mA$ |
| | | 4.5 | | 4 | 7 | Ω | $V_{IN} = 0V, I_{IN} = 30mA$ |
| | | 4.5 | | 8 | 12 | Ω | $V_{IN} = 2.4V, I_{IN} = 15mA$ |
| | | 4.0 | | 14 | 20 | Ω | $V_{IN} = 2.4V, I_{IN} = 15mA$ |
| I_{CC} | Quiescent Supply Current | 5.5 | | | 3 | μA | $V_{IN} = V_{CC}$ or GND, $I_{OUT} = 0$ |
| ΔI_{CC} | Increase in I_{CC} per Input | 5.5 | | | 2.5 | mA | One input at 3.4V Other inputs at V_{CC} or GND |

Note 4: Typical values are at $V_{CC} = 5.0V$ and $T_A = +25\text{ °C}$

Note 5: Measured by the voltage drop between A and B pins at the indicated current through the switch. On resistance is determined by the lower of the voltages on the two (A or B) pins.

AC Electrical Characteristics

| Symbol | Parameter | $T_A = -40\text{ }^\circ\text{C to } +85\text{ }^\circ\text{C}$, $C_L = 50\text{ pF}$, $R_U = R_D = 500\Omega$ | | | | Units | Conditions | Figure No. |
|--------------------|---------------------------------|---|------|------------------------|------|-------|--|----------------------|
| | | $V_{CC} = 4.5 - 5.5\text{V}$ | | $V_{CC} = 4.0\text{V}$ | | | | |
| | | Min | Max | Min | Max | | | |
| t_{PHL}, t_{PLH} | Prop Delay Bus to Bus (Note 6) | | 0.25 | | 0.25 | ns | $V_I = \text{OPEN}$ | Figure 1 Figure 2 |
| t_{PHL}, t_{PLH} | Prop Delay S to Bus | 1.5 | 7.0 | | 7.5 | ns | $V_I = \text{OPEN}$ | Figure 1 Figure 2 |
| t_{PZH}, t_{PZL} | Output Enable Time, S to A or B | 1.5 | 7.5 | | 8.0 | ns | $V_I = 7\text{V}$ for t_{PZL} $V_I = \text{OPEN}$ for t_{PZH} | Figure 1 Figure 2 |
| t_{PHZ}, t_{PLZ} | Output Disable Time S to A or B | 1.0 | 8.5 | | 9.0 | ns | $V_I = 7\text{V}$ for t_{PLZ} $V_I = \text{OPEN}$ for t_{PHZ} | Figure 1 Figure 2 |

Note 6: This parameter is guaranteed by design but is not tested. The bus switch contributes no propagation delay other than the RC delay of the typical On resistance of the switch and the 50pF load capacitance, when driven by an ideal voltage source (zero output impedance).

Capacitance (Note 7)

| Symbol | Parameter | Typ | Max | Units | Conditions |
|----------|-------------------------------|-----|-----|-------|--|
| C_{IN} | Control pin Input Capacitance | 3 | | pF | $V_{CC} = 5.0\text{V}$ |
| C_{IO} | Input/Output Capacitance | 10 | | pF | $V_{CC} = 5.0\text{V}$, S0, S1, or S2 = GND |

Note 7: $T_A = +25\text{ }^\circ\text{C}$, $f = 1\text{ MHz}$. Capacitance is characterized but not tested.

AC Loading and Waveforms

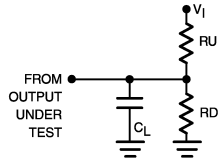

Note: Input driven by 50 Ω source terminated in 50 Ω

Note: C_L includes load and stray capacitance

Note Input PRR = 1.0 MHz, $t_W = 500\text{ ns}$

FIGURE 1. AC Test Circuit

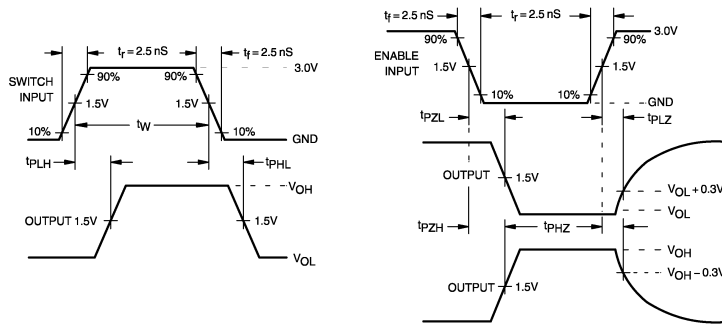
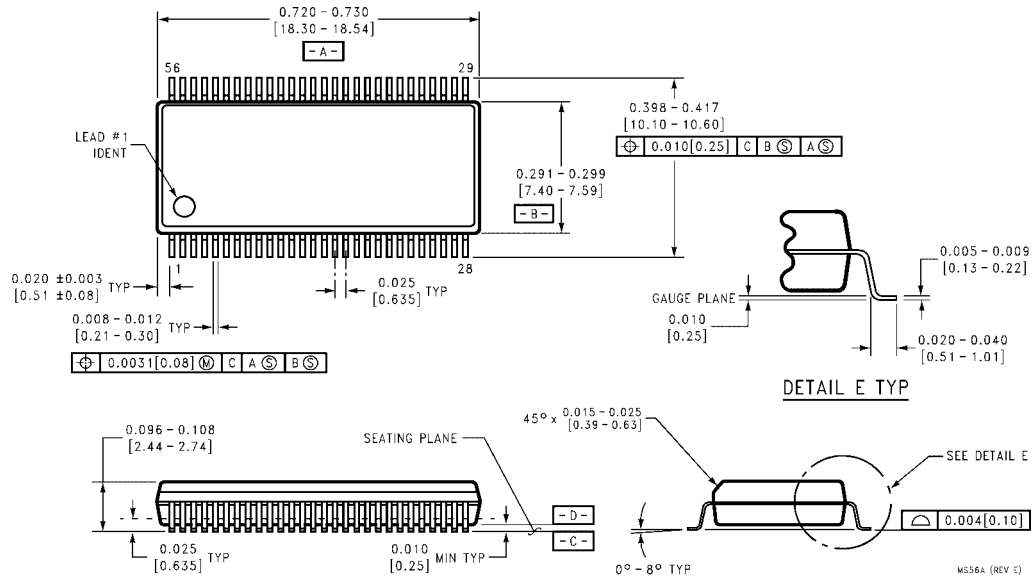

FIGURE 2. AC Waveforms

FST16212

Physical Dimensions inches (millimeters) unless otherwise noted



**56-Lead Shrink Small Outline Package (SSOP), JEDEC MO-118, 0.300 Wide
Package Number MS56A**

MS56A (REV 3)

