

1mm Pitch Connector for Vertical Connection

FX5 Series

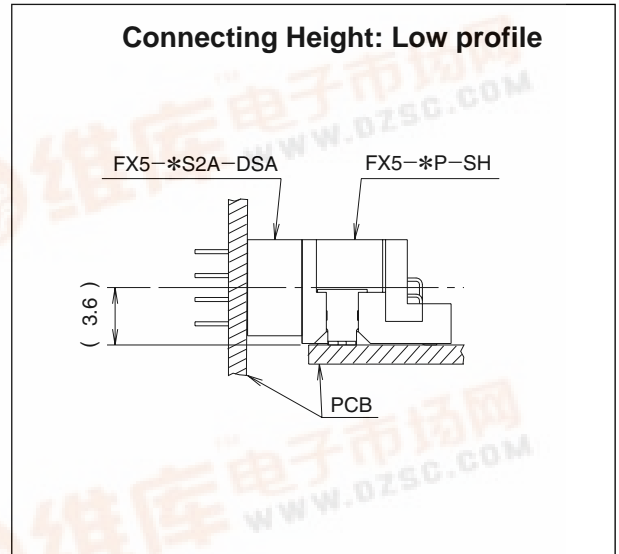
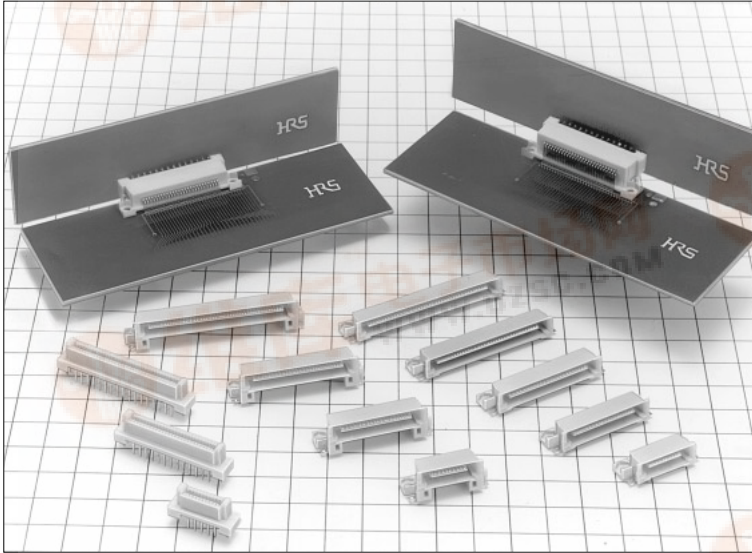

■Features

1. Header Side : 2 Types Available

Two header types, low profile and high profile, are prepared according to the contact number variation and the connecting height variation, considering unit connections of HDD, FDD, CD-ROM and so on.

2. Two-stages Sequential Structure

The connecting sequence is designed with 2 stages so that the end user side can maintain.

3. Mating Guide

In the connecting process, the self-alignment is ± 1 mm high sufficient to the guide level, and the guide rib is provided to achieve easy mating.

4. SMT Coplanarity

The coplanarity of SMT soldered area secures the high accuracy of 0.1mm.

5. Miniaturization

The connector is miniaturized about 30% in the mounting area, compared with the conventional half pitch connector (1.27mm).

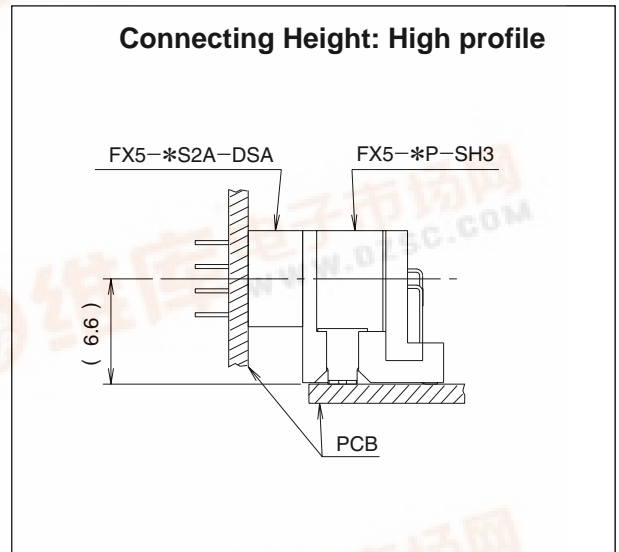

■Applications

Note PC , other business equipments

■Product Specifications

Rating	Current rating 0.5A	Operating Temperature Range -55°C to +85°C (Note 1)	Storage Temperature Range -10°C to +60°C (Note 2)
	Voltage rating 100V AC	Operating Humidity Range 40% to 80%	Storage Humidity Range 40% to 70%

Item	Specifications	Condition
1. Insulation Resistance	100M ohms min.	250V DC
2. Withstanding voltage	No flashover or insulation breakdown.	300V AC/1 minute
3. Contact Resistance	50m ohms max.	100mA
4. Vibration	No electrical discontinuity of 1μs or more	Frequency: 10 to 55 Hz, single amplitude of 0.75 mm, 2 hours in each of the 3 directions.
5. Moisture Resistance	Contact resistance: 60m ohms max. Insulation resistance: 100M ohms min.	96 hours at temperature of 40°C and humidity of 90% to 95%
6. Temperature Cycle	Contact resistance: 60m ohms max. Insulation resistance: 100M ohms min.	(-55°C: 30 minutes, 15 to 35°C: 2 to 3 minutes 85°C: 30 minutes, 15 to 35°C: 2 to 3minutes) 5 cycles
7. Durability (Mating/un-mating)	Contact resistance: 60m ohms max.	500 cycles
8. Resistance to Soldering heat	No deformation of components affecting performance.	Reflow: At the recommended temperature profile
		Manual soldering: 300°C for 3 seconds

Note 1: Includes temperature rise caused by current flow.

Note 2: The term "storage" refers to products stored for long period of time prior to mounting and use. Operating Temperature Range and Humidity range covers non conducting condition of installed connectors in storage, shipment or during transportation.

■Material

Part	Material	Finish	Remarks
Insulator	Polyamide	Beige	UL94V-0
Header Contact	Brass	Contact area : Gold plated	—————
Receptacle Contact	Phosphor bronze	Lead area : Tin-lead plated	—————

Note : The black dots on the insulator will not affect performance.

■Ordering Information

●Header

FX5 - * **P** - **SH** **3**

① ② ③ ④ ⑤

① Series Name : FX5	⑤ Connector Height Blank : 6.5mm 3 : 9.5mm
② Number of Contacts : 20, 40, 52, 56, 68, 80	
③ Connector Type P: Header	
④ Contact type SH : Right angle SMT type	

Note: The 56 contact header is for SH 3 type only.

●Receptacle

FX5 - * **S** **2** **A** - **DSA** **L**

① ② ③ ④ ⑤ ⑥ ⑦

① Series Name : FX5	⑥ Contact type DSA : Straight through hole type
② Number of Contacts : 20, 40, 52, 56, 68, 80	
③ Connector Type S: Receptacle	⑦ Board prefixed pin Blank : Without board prefixed pin L : With board Prefixed pin
④ Contact Sequence 2 : 2 Stages Sequence	
⑤ Serial No. : A	

Header **Low profile**

Header **High profile**

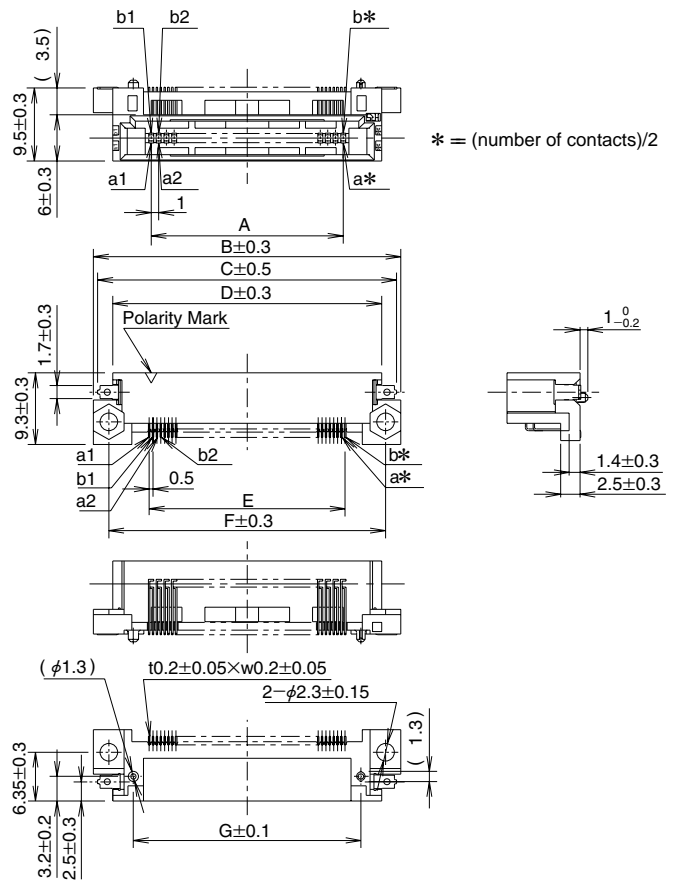
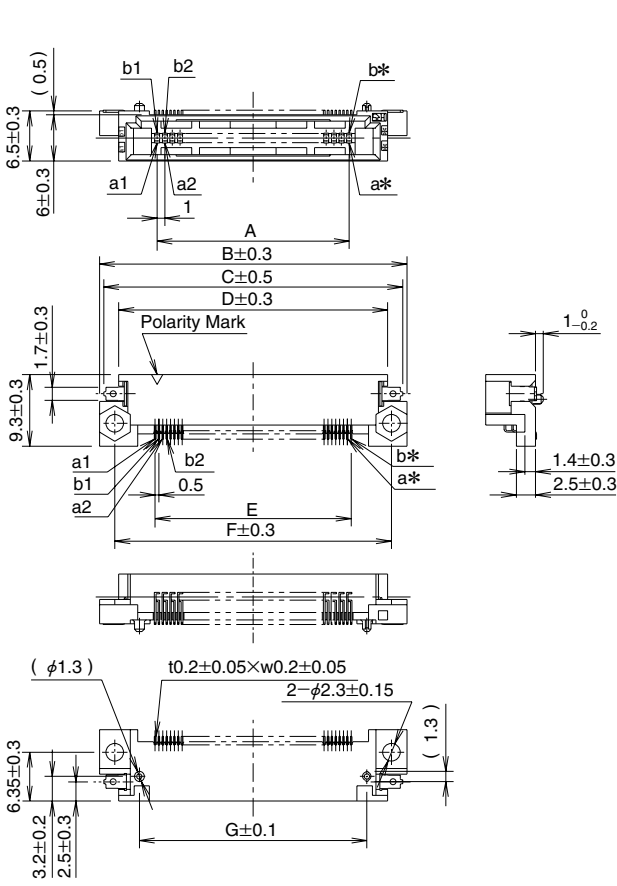

* = (number of contacts)/2

Unit: mm

Part Number	CL No.	Number of Contacts	A	B	C	D	E	F	G
FX5-20P-SH	575-0001-7	20	9	24	22.9	19	9.5	20	13.6
FX5-20P-SH3	575-0041-1								
FX5-40P-SH	575-0005-8	40	19	34	32.9	29	19.5	30	23.6
FX5-40P-SH3	575-0045-2								
FX5-52P-SH	575-0006-0	52	25	40	38.9	35	25.5	36	29.6
FX5-52P-SH3	575-0046-5								
FX5-56P-SH3	575-1001-2	56	27	42	40.9	37	27.5	38	31.6
FX5-68P-SH	575-0008-6	68	33	48	46.9	43	33.5	44	37.6
FX5-68P-SH3	575-0048-0								
FX5-80P-SH	575-0009-9	80	39	54	52.9	49	39.5	50	43.6
FX5-80P-SH3	575-0049-3								

■ Receptacle

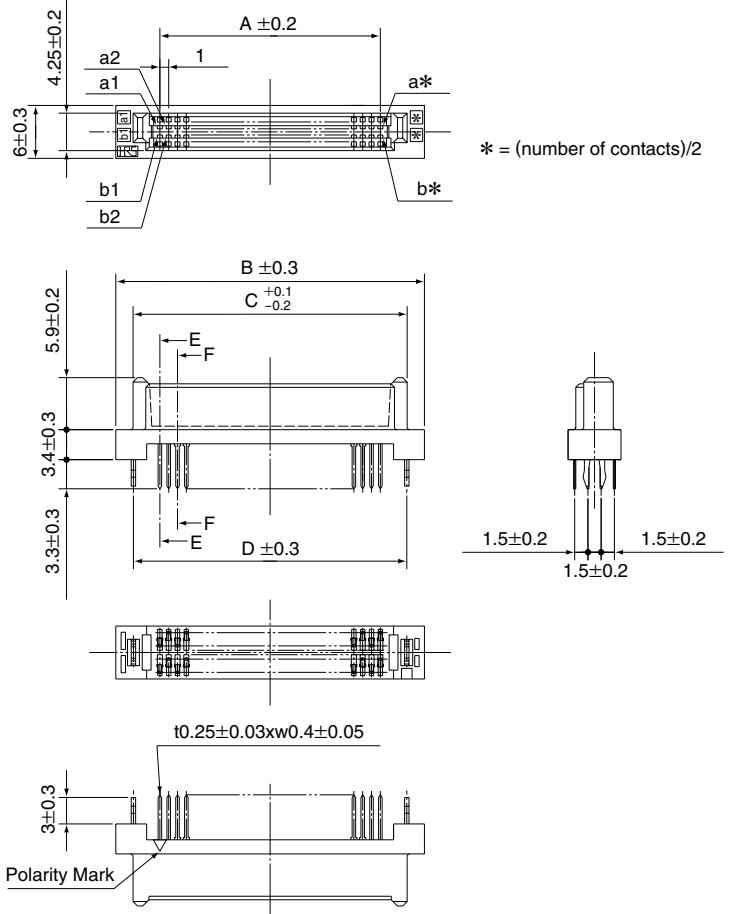
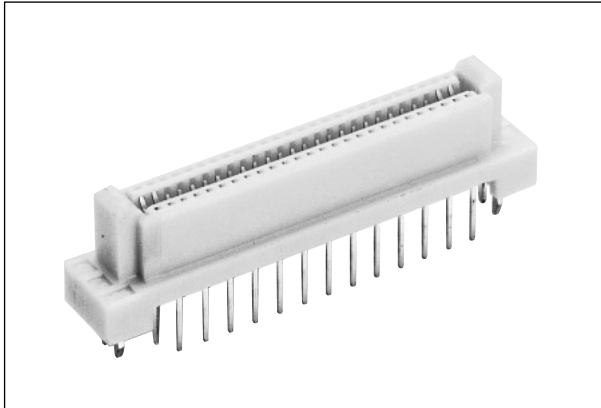

Unit: mm

Part Number	CL No.	Number of Contacts	A	B	C	D	Order of Contact Sequence(Contact No.)	
							1	2
FX5-20S2A-DSA	575-0101-1	20	9	19	15.08	—	a1,a2,a9,a10	a3 to a8
FX5-20S2A-DSAL	575-0121-9					15	b1,b2,b9,b10	b3 to b8
FX5-40S2A-DSA	575-0105-2	40	19	29	25.08	—	a1,a2,a19,a20	a3 to a18
FX5-40S2A-DSAL	575-0125-0					25	b1,b2,b19,b20	b3 to b18
FX5-52S2A-DSA	575-0106-5	52	25	35	31.08	—	a1,a2,a25,a26	a3 to a24
FX5-52S2A-DSAL	575-0126-2					31	b1,b2,b25,b26	b3 to b24
FX5-56S2A-DSA	575-0107-8	56	27	37	33.08	—	a1,a2,a27,a28	a3 to a26
FX5-56S2A-DSAL	575-0127-5					33	b1,b2,b27,b28	b3 to b26
FX5-68S2A-DSA	575-0108-0	68	33	43	39.08	—	a1,a2,a33,a34	a3 to a32
FX5-68S2A-DSAL	575-0128-8					39	b1,b2,b33,b34	b3 to b32
FX5-80S2A-DSA	575-0109-3	80	39	49	45.08	—	a1,a2,a39,a40	a3 to a38
FX5-80S2A-DSAL	575-0129-0					45	b1,b2,b39,b40	b3 to b38

◆PCB mounting pattern

●Header

FX5-*-SH, FX5-*-SH3

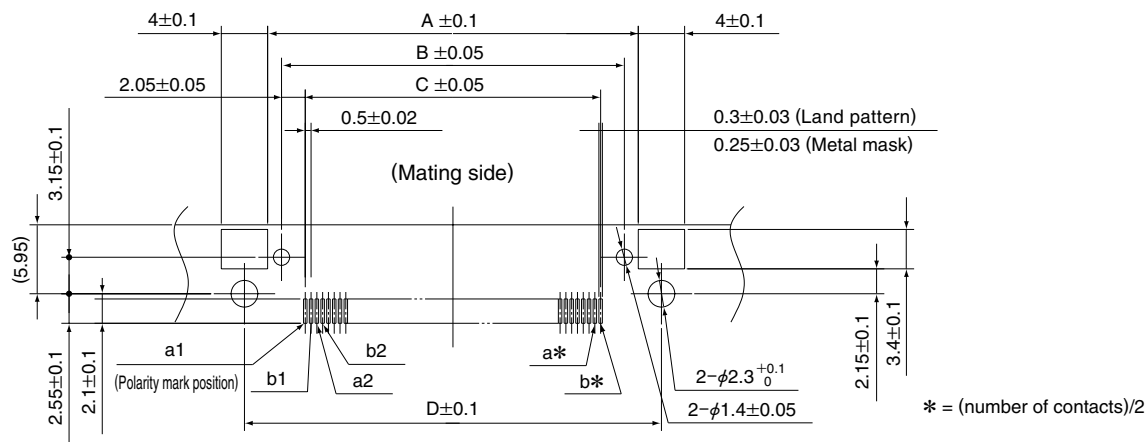

●Receptacle

FX5-*-S2A-DSA

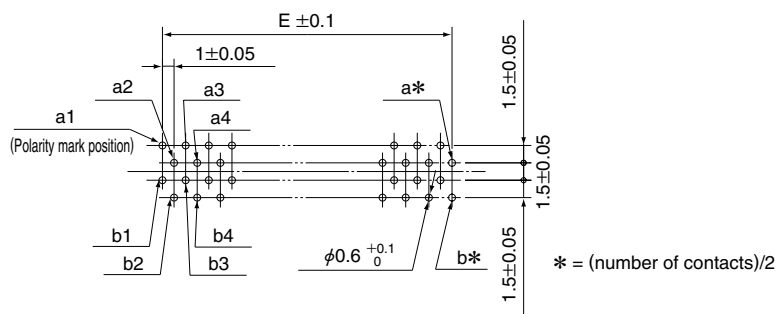

FX5-*-S2A-DSAL

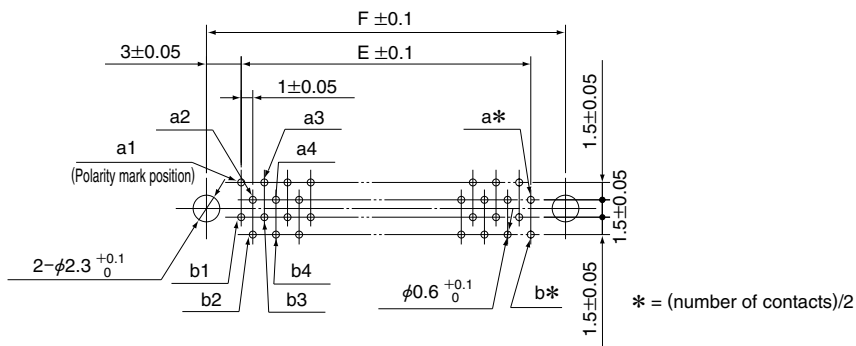

Unit: mm

Number of Contacts	A	B	C	D	E	F
20	16	13.6	9.5	20	9	15
40	26	23.6	19.5	30	19	25
52	32	29.6	25.5	36	25	31
56	34	31.6	27.5	38	27	33
68	40	37.6	33.5	44	33	39
80	46	43.6	39.5	50	39	45

Note: If the connector is installed in the board beyond the above recommended size, it may cause the connector to board mounting failure or the soldering failure. It is desirable to implement the board process on the recommended PCB mounting pattern.

◆ Recommended Temperature Profile

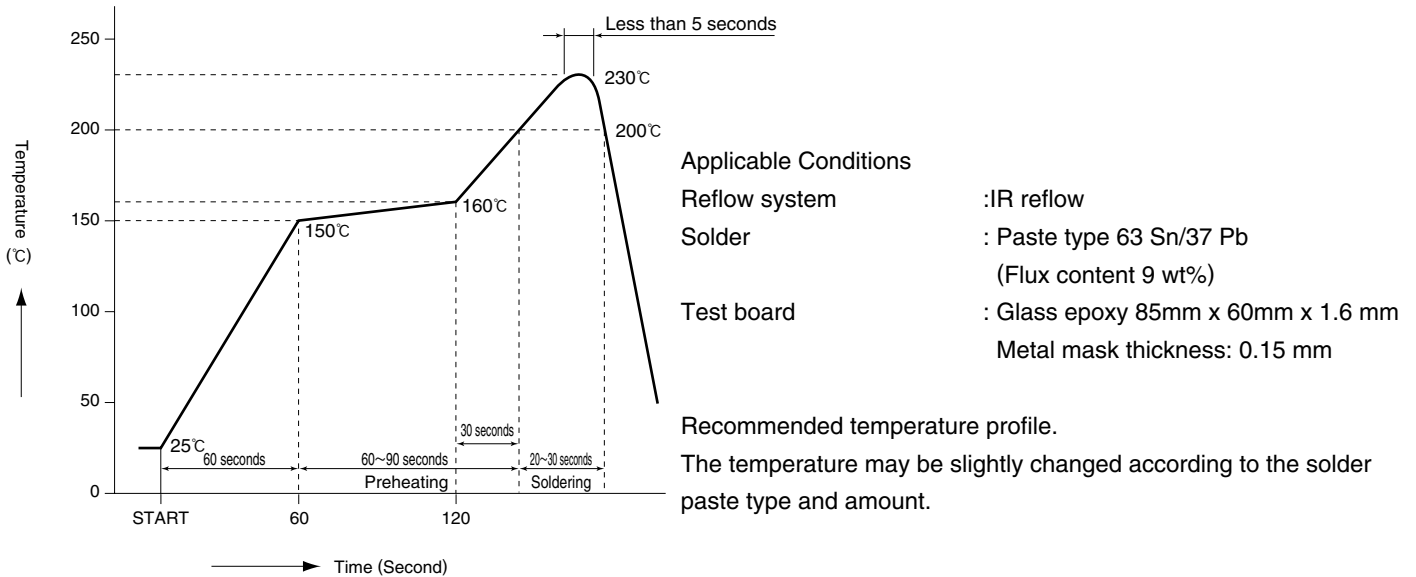

◆ Cleaning Conditions

1. Organic Solvent Cleaning

Solvent	Cold Cleaning	Heat Cleaning
IPA (Isopropyl alcohol)	○	○
HCFC (Hydrochlorophloro carbon)	○	○

*Methylene chloride isn't suitable for this product solvent.

2. Liquid Cleaning

When liquid detergents (such as terpene, alkali saponifier) are used, please select the cleaning detergent according to the influence table on metal or resin which is issued from each detergent manufacturer. In addition, please do not leave the connector outdoor, in which moisture remains.

3. Cautions for Cleaning

As for organic solvent or liquid cleaning, if flux or detergent remains on the connector, it can cause electrical performance degradation. Therefore, please make sure that the connector is thoroughly cleaned so that neither flux nor detergent is found on the connector.

◆ Connector Precautions

1. Tolerance Clearance on Mating Side

The effective connection clearance of the product is 1.6mm. Please use the product so as to specify within 1mm the clearance between the header and the receptacle in the connection process.

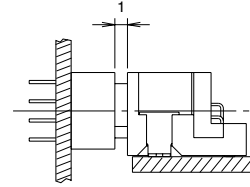

2. Header Connector Height

The SMT connector height doesn't include the solder paste thickness. Thus, please consider that the stacking height will slightly increase after the mounting process.

Mating Height: Low profile

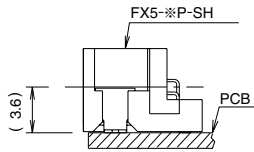

Mating Height: High profile

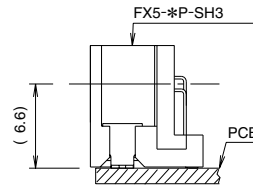

3. Screw Fastening Torque (SMT Type)

When the screw is fastened, please use the M2 screw. The recommended fastening torque is 0.15(N.m) max.

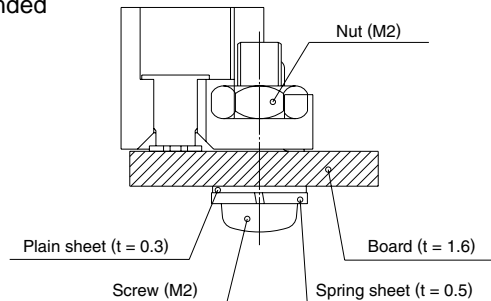

4. Prefixed Process to Board (Through hole Type)

If the prefixed process is required for board mounting, please use the prefixed pin type. (Applicable Thickness $t = 1.6 \pm 0.1$)

Note:

When the connector is mounted on the board, the dip post is guided into the board through-hole in order to prevent the dip post damage, and then insert the board in parallel to the connector so as to push in the prefixed pin.

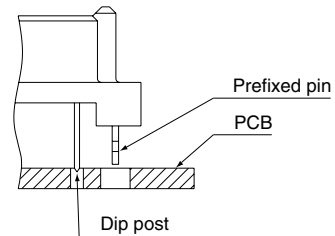

5. Plug and Play

When the connector is inserted or extracted in the active line state, please contact HRS company.

6. Others

- It is noted that the forced excessive insertion/extraction will result in damage.
- Avoid holding the board with the connector only, and fix the board by any other means except for the connector.
- The color phase of this product may be slightly different from that of the forming product according to the manufacturing lot, but the difference doesn't affect the performance.