

FAIRCHILD
SEMICONDUCTOR™

April 2003
Revised January 2004

FXLP34 Single Bit Uni-Directional Translator

General Description

The FXLP34 is a single translator with two separate supply voltages: V_{CC1} for input translation voltages and V_{CC} for output translation voltages. The FXLP34 is part of Fairchild's Ultra Low Power (ULP) series of products. This device operates with V_{CC} values from 1.0V to 3.6V, and is intended for use in portable applications that require ultra low power consumption.

The internal circuit is composed of a minimum of buffer stages, to enable ultra low dynamic power.

The FXLP34 is uniquely designed for optimized power and speed, and is fabricated with an advanced CMOS technology to achieve high-speed operation while maintaining low CMOS power dissipation.

Features

- 1.0V to 3.6V V_{CC} supply operation
- Converts any voltage (1.0V to 3.6V) to (1.0V to 3.6V)
- 4.6V tolerant inputs and outputs
- t_{PD}
 - 4 ns typ for 3.0V to 3.6V V_{CC}
 - 5 ns typ for 2.3V to 2.7V V_{CC}
 - 6 ns typ for 1.65V to 1.95V V_{CC}
 - 7 ns typ for 1.40V to 1.60V V_{CC}
 - 11 ns typ for 1.10V to 1.30V V_{CC}
 - 27 ns typ for 1.0V V_{CC}
- Power-Off high impedance inputs and outputs
- Static Drive (I_{OH}/I_{OL})
 - ±2.6 mA @ 3.00V V_{CC}
 - ±2.1 mA @ 2.30V V_{CC}
 - ±1.5 mA @ 1.65V V_{CC}
 - ±1.0 mA @ 1.40V V_{CC}
 - ±0.5 mA @ 1.10V V_{CC}
 - ±20 μ A @ 1.0V V_{CC}
- Uses patented Quiet Series™ noise/EMI reduction circuitry
- Ultra small MicroPak™ leadless package
- Ultra low dynamic power

Ordering Code:

Order Number	Package Number	Product Code Top Mark	Package Description	Supplied As
FXLP34P5X	MAA05A	X34	5-Lead SC70, EIAJ SC-88a, 1.25mm Wide	3k Units on Tape and Reel
FXLP34L6X	MAC06A	X3	6-Lead MicroPak, 1.0mm Wide	5k Units on Tape and Reel

MicroPak™ and Quiet Series™ are trademarks of Fairchild Semiconductor Corporation.

FXLP34 Single Bit Uni-Directional Translator



Pin Descriptions

Pin Names	Description
A	Input
Y	Output
NC	No Connect
V _{CC1}	Input Translation Voltage
V _{CC}	Output Translation Voltage

Function Table

$$Y = A$$

Inputs	Output
A	Y
L	L
H	H

H = HIGH Logic Level
L = LOW Logic Level

Connection Diagrams

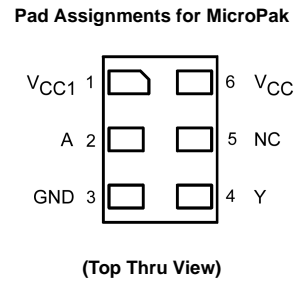
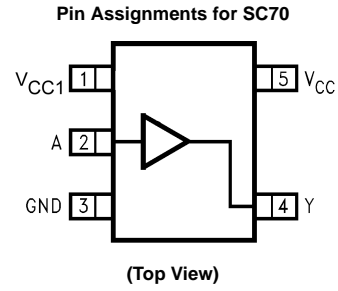

Absolute Maximum Ratings (Note 1)				Recommended Operating Conditions (Note 3)					
Supply Voltage (V_{CC}, V_{CC1})		-0.5V to +4.6V		Supply Voltage (V_{CC}, V_{CC1})		1.0V to 3.6V			
DC Input Voltage (V_{IN})		-0.5V to +4.6V		Input Voltage (V_{IN})		0.0V to 3.6V			
DC Output Voltage (V_{OUT})				Output Voltage (V_{OUT})					
HIGH or LOW State (Note 2)		-0.5V to $V_{CC} + 0.5V$		HIGH or LOW State		0V to V_{CC}			
$V_{CC} = 0V$		-0.5V to 4.6V		$V_{CC} = 0V$		0V to 3.6V			
DC Input Diode Current (I_{IK}) $V_{IN} < 0V$		± 50 mA		Output Current in I_{OH}/I_{OL}					
DC Output Diode Current (I_{OK})				$V_{CC} = 3.0V$ to 3.6V		± 2.6 mA			
$V_{OUT} < 0V$		-50 mA		$V_{CC} = 2.3V$ to 2.7V		± 2.1 mA			
$V_{OUT} < V_{CC}$		+50 mA		$V_{CC} = 1.65V$ to 1.95V		± 1.5 mA			
DC Output Source/Sink Current (I_{OH}/I_{OL})		± 50 mA		$V_{CC} = 1.40V$ to 1.60V		± 1.0 mA			
DC V_{CC} or Ground Current per				$V_{CC} = 1.10V$ to 1.30V		± 0.5 mA			
Supply Pin (I_{CC} or Ground)		± 100 mA		$V_{CC} = 1.0V$		± 20 μ A			
Storage Temperature Range (T_{STG})		-65°C to +150°C		Free Air Operating Temperature (T_A)		-40°C to +85°C			
				Minimum Input Edge Rate ($\Delta t/\Delta V$)					
				$V_{IN} = 0.8V$ to 2.0V, $V_{CC1} = 3.0V$		10 ns/V			
				Note 1: Absolute Maximum Ratings: are those values beyond which the safety of the device cannot be guaranteed. The device should not be operated at these limits. The parametric values defined in the Electrical Characteristics tables are not guaranteed at the absolute maximum ratings. The "Recommended Operating Conditions" table will define the conditions for actual device operation.					
				Note 2: I_O Absolute Maximum Rating must be observed.					
				Note 3: Unused inputs must be held HIGH or LOW. They may not float.					
DC Electrical Characteristics									
Symbol	Parameter	V_{CC} (V)	V_{CC1} (V)	$T_A = +25^\circ C$		$T_A = -40^\circ C$ to $+85^\circ C$		Units	Conditions
				Min	Max	Min	Max		
V_{IH}	HIGH Level Input Voltage (V_{CC1})	1.0 to 3.6	1.0	$0.65 \times V_{CC1}$	$0.65 \times V_{CC1}$	$0.65 \times V_{CC1}$	$0.65 \times V_{CC1}$	V	
			$1.10 \leq V_{CC1} \leq 1.30$	$0.65 \times V_{CC1}$	$0.65 \times V_{CC1}$	$0.65 \times V_{CC1}$			
			$1.40 \leq V_{CC1} \leq 1.60$	$0.65 \times V_{CC1}$	$0.65 \times V_{CC1}$	$0.65 \times V_{CC1}$			
			$1.65 \leq V_{CC1} \leq 1.95$	$0.65 \times V_{CC1}$	$0.65 \times V_{CC1}$	$0.65 \times V_{CC1}$			
			$2.30 \leq V_{CC1} \leq 2.70$	1.6	1.6	1.6			
			$3.00 \leq V_{CC1} \leq 3.60$	2.1	2.1	2.1			
V_{IL}	LOW Level Input Voltage	1.0 to 3.6	1.0	$0.35 \times V_{CC1}$	$0.35 \times V_{CC1}$	$0.35 \times V_{CC1}$	$0.35 \times V_{CC1}$	V	
			$1.10 \leq V_{CC1} \leq 1.30$	$0.35 \times V_{CC1}$	$0.35 \times V_{CC1}$	$0.35 \times V_{CC1}$			
			$1.40 \leq V_{CC1} \leq 1.60$	$0.35 \times V_{CC1}$	$0.35 \times V_{CC1}$	$0.35 \times V_{CC1}$			
			$1.65 \leq V_{CC1} \leq 1.95$	$0.35 \times V_{CC1}$	$0.35 \times V_{CC1}$	$0.35 \times V_{CC1}$			
			$2.30 \leq V_{CC1} \leq 2.70$	0.7	0.7	0.7			
			$3.00 \leq V_{CC1} \leq 3.60$	0.9	0.9	0.9			
V_{OH}	HIGH Level Output Voltage (V_{CC})	1.0		$V_{CC} - 0.1$	$V_{CC} - 0.1$	$V_{CC} - 0.1$	$V_{CC} - 0.1$	V	$I_{OH} = -20 \mu A$
		$1.10 \leq V_{CC} \leq 1.30$		$V_{CC} - 0.1$	$V_{CC} - 0.1$	$V_{CC} - 0.1$	$V_{CC} - 0.1$		
		$1.40 \leq V_{CC} \leq 1.60$		$V_{CC} - 0.1$	$V_{CC} - 0.1$	$V_{CC} - 0.1$	$V_{CC} - 0.1$		
		$1.65 \leq V_{CC} \leq 1.95$	1.0 to 3.6	$V_{CC} - 0.1$	$V_{CC} - 0.1$	$V_{CC} - 0.1$	$V_{CC} - 0.1$		
		$2.30 \leq V_{CC} \leq 2.70$		$V_{CC} - 0.1$	$V_{CC} - 0.1$	$V_{CC} - 0.1$	$V_{CC} - 0.1$		
		$3.00 \leq V_{CC} \leq 3.60$		$V_{CC} - 0.1$	$V_{CC} - 0.1$	$V_{CC} - 0.1$	$V_{CC} - 0.1$		
		$1.10 \leq V_{CC} \leq 1.30$	1.0 to 3.6	$0.75 \times V_{CC}$	$0.70 \times V_{CC}$	$0.70 \times V_{CC}$	$0.70 \times V_{CC}$		
$1.40 \leq V_{CC} \leq 1.60$	1.0 to 3.6	1.07	0.99	0.99	0.99				
$1.65 \leq V_{CC} \leq 1.95$	1.0 to 3.6	1.24	1.22	1.22	1.22				
$2.30 \leq V_{CC} \leq 2.70$	1.0 to 3.6	1.95	1.87	1.87	1.87				
$3.00 \leq V_{CC} \leq 3.60$	1.0 to 3.6	2.61	2.55	2.55	2.55				
								$I_{OH} = -0.5$ mA	
								$I_{OH} = -1.0$ mA	
								$I_{OH} = -1.5$ mA	
								$I_{OH} = -2.1$ mA	
								$I_{OH} = -2.6$ mA	

DC Electrical Characteristics (Continued)										
Symbol	Parameter	V _{CC} (V)	V _{CC1} (V)	T _A = +25°C		T _A = -40°C to +85°C		Units	Conditions	
				Min	Max	Min	Max			
V _{OL}	LOW Level	1.0	1.0 to 3.6		0.1		0.1	V	I _{OL} = 20 μA	
	Output Voltage	1.10 ≤ V _{CC} ≤ 1.30			0.1		0.1			
		1.40 ≤ V _{CC} ≤ 1.60			0.1		0.1			
		1.65 ≤ V _{CC} ≤ 1.95			0.1		0.1			
		2.30 ≤ V _{CC} ≤ 2.70			0.1		0.1			
		3.00 ≤ V _{CC} ≤ 3.60			0.1		0.1			
	1.10 ≤ V _{CC} ≤ 1.30	1.0 to 3.6		0.30 x V _{CC}		0.30 x V _{CC}				I _{OL} = 0.5 mA
	1.40 ≤ V _{CC} ≤ 1.60	1.0 to 3.6		0.31		0.37				I _{OL} = 1.0 mA
	1.65 ≤ V _{CC} ≤ 1.95	1.0 to 3.6		0.31		0.35				I _{OL} = 1.5 mA
2.30 ≤ V _{CC} ≤ 2.70	1.0 to 3.6	0.31		0.33		I _{OL} = 2.1 mA				
3.00 ≤ V _{CC} ≤ 3.60	1.0 to 3.6	0.31		0.33		I _{OL} = 2.6 mA				
I _{IN}	Input Leakage Current		1.0 to 3.60	±0.1		±1.0		μA	0 ≤ V _I ≤ 3.6V	
I _{OFF}	Power Off Leakage Current	0	0	1.0		5.0		μA	0 ≤ (V _I , V _O) ≤ 3.6V	
I _{CC}	Quiescent Supply Current	1.0 to 3.60	1.0 to 3.6	0.9		5.0		μA	V _I = V _{CC} or GND	
AC Electrical Characteristics										
Symbol	Parameter	V _{CC1} (V)	T _A = +25°C			T _A = -40°C to +85°C		Units	Conditions	Figure Number
			Min	Typ	Max	Min	Max			
t _{PHL}	Propagation Delay	1.0	26.0					ns	C _L = 10 pF R _L = 1 MΩ	Figures 1, 2
t _{PLH}	Output Translation V _{CC} (V) = 1.0	1.10 to 1.30	15.0	25.0	38.1	12.0	43.3			
		1.40 to 1.60	14.0	24.0	36.7	11.0	42.0			
		1.65 to 1.95	13.0	23.0	36.0	10.0	41.4			
		2.30 to 2.70	12.0	22.0	35.5	9.0	40.9			
		3.00 to 3.60	11.0	21.0	35.5	8.0	40.6			
t _{PHL}	Propagation Delay	1.0	18.0					ns	C _L = 10 pF R _L = 1 MΩ	Figures 1, 2
t _{PLH}	Output Translation V _{CC} (V) = 1.2	1.10 to 1.30	8.0	15.0	23.2	6.0	41.0			
		1.40 to 1.60	7.5	14.0	21.7	5.5	39.1			
		1.65 to 1.95	7.0	13.0	20.9	5.0	32.3			
		2.30 to 2.70	6.5	12.0	20.4	4.5	29.6			
		3.00 to 3.60	6.0	12.0	20.2	4.0	29.4			
t _{PHL}	Propagation Delay	1.0	14.0					ns	C _L = 10 pF R _L = 1 MΩ	Figures 1, 2
t _{PLH}	Output Translation V _{CC} (V) = 1.5	1.10 to 1.30	5.0	11.0	16.3	4.0	20.6			
		1.40 to 1.60	4.8	10.0	14.8	3.5	19.3			
		1.65 to 1.95	4.5	9.0	14.1	3.0	18.7			
		2.30 to 2.70	4.0	8.0	13.5	2.5	18.0			
		3.00 to 3.60	3.5	8.0	13.3	2.0	17.8			
t _{PHL}	Propagation Delay	1.0	13.0					ns	C _L = 10 pF R _L = 1 MΩ	Figures 1, 2
t _{PLH}	Output Translation V _{CC} (V) = 1.8	1.10 to 1.30	4.0	9.0	13.5	3.0	17.5			
		1.40 to 1.60	3.5	8.0	12.0	2.5	16.3			
		1.65 to 1.95	3.0	7.0	11.3	2.0	15.6			
		2.30 to 2.70	2.5	6.0	10.7	1.5	15.0			
		3.00 to 3.60	2.5	6.0	10.5	1.0	14.7			
t _{PHL}	Propagation Delay	1.0	12.0					ns	C _L = 10 pF R _L = 1 MΩ	Figures 1, 2
t _{PLH}	Output Translation V _{CC} (V) = 2.5	1.10 to 1.30	3.0	7.0	10.9	2.5	14.3			
		1.40 to 1.60	2.5	6.0	9.4	2.0	13.1			
		1.65 to 1.95	2.0	5.0	8.6	1.5	11.4			
		2.30 to 2.70	1.5	4.0	8.0	1.0	10.8			
		3.00 to 3.60	1.5	4.0	7.8	1.0	10.5			

AC Electrical Characteristics (Continued)										
Symbol	Parameter	V _{CC1} (V)	T _A = +25°C			T _A = -40°C to +85°C		Units	Conditions	Figure Number
			Min	Typ	Max	Min	Max			
t _{PHL} t _{PLH}	Propagation Delay Output Translation V _{CC} (V) = 3.3	1.0 1.10 to 1.30 1.40 to 1.60 1.65 to 1.95 2.30 to 2.70 3.00 to 3.60		11.0			2.0 13.8 1.5 10.5 1.0 9.9 1.0 9.2 1.0 9.0	ns	C _L = 10 pF R _L = 1 MΩ	Figures 1, 2
t _{PHL} t _{PLH}	Propagation Delay Output Translation V _{CC} (V) = 1.0	1.0 1.10 to 1.30 1.40 to 1.60 1.65 to 1.95 2.30 to 2.70 3.00 to 3.60		28.0			12.0 44.8 11.0 43.6 10.0 47.9 9.0 47.5 8.0 41.4	ns	C _L = 15 pF R _L = 1 MΩ	Figures 1, 2
t _{PHL} t _{PLH}	Propagation Delay Output Translation V _{CC} (V) = 1.2	1.0 1.10 to 1.30 1.40 to 1.60 1.65 to 1.95 2.30 to 2.70 3.00 to 3.60		19.0			8.0 43.1 7.5 42.2 7.0 31.4 6.5 30.7 6.0 30.5	ns	C _L = 15 pF R _L = 1 MΩ	Figures 1, 2
t _{PHL} t _{PLH}	Propagation Delay Output Translation V _{CC} (V) = 1.5	1.0 1.10 to 1.30 1.40 to 1.60 1.65 to 1.95 2.30 to 2.70 3.00 to 3.60		15.0			5.5 21.5 5.0 20.3 4.5 19.6 4.0 18.9 3.5 18.7	ns	C _L = 15 pF R _L = 1 MΩ	Figures 1, 2
t _{PHL} t _{PLH}	Propagation Delay Output Translation V _{CC} (V) = 1.8	1.0 1.10 to 1.30 1.40 to 1.60 1.65 to 1.95 2.30 to 2.70 3.00 to 3.60		14.0			5.5 18.2 4.0 17.0 3.5 16.3 3.0 15.7 2.5 14.4	ns	C _L = 15 pF R _L = 1 MΩ	Figures 1, 2
t _{PHL} t _{PLH}	Propagation Delay Output Translation V _{CC} (V) = 2.5	1.0 1.10 to 1.30 1.40 to 1.60 1.65 to 1.95 2.30 to 2.70 3.00 to 3.60		12.0			3.5 14.9 3.0 13.6 2.5 12.0 2.0 11.3 2.0 11.1	ns	C _L = 15 pF R _L = 1 MΩ	Figures 1, 2
t _{PHL} t _{PLH}	Propagation Delay Output Translation V _{CC} (V) = 3.3	1.0 1.10 to 1.30 1.40 to 1.60 1.65 to 1.95 2.30 to 2.70 3.00 to 3.60		11.0			2.0 14.2 1.5 11.0 1.0 10.3 1.0 9.7 1.0 9.4	ns	C _L = 15 pF R _L = 1 MΩ	Figures 1, 2
t _{PHL} t _{PLH}	Propagation Delay Output Translation V _{CC} (V) = 1.0	1.0 1.10 to 1.30 1.40 to 1.60 1.65 to 1.95 2.30 to 2.70 3.00 to 3.60		34.0			15.0 55.5 14.0 52.3 13.0 50.6 12.0 49.2 10.0 49.1	ns	C _L = 30 pF R _L = 1 MΩ	Figures 1, 2

AC Electrical Characteristics (Continued)										
Symbol	Parameter	V _{CC1} (V)	T _A = +25°C			T _A = -40°C to +85°C		Units	Conditions	Figure Number
			Min	Typ	Max	Min	Max			
t _{PHL}	Propagation Delay	1.0		22.0						
t _{PLH}	Output Translation	1.10 to 1.30	11.0	19.0	29.0	10.0	46.5	ns	C _L = 30 pF R _L = 1 MΩ	Figures 1, 2
	V _{CC} (V) = 1.2	1.40 to 1.60	10.0	18.0	27.5	9.0	42.6			
		1.65 to 1.95	9.0	17.0	26.7	8.0	36.7			
		2.30 to 2.70	8.5	16.0	26.1	7.0	36.0			
		3.00 to 3.60	8.0	16.0	26.0	6.0	35.9			
t _{PHL}	Propagation Delay	1.0		16.0						
t _{PLH}	Output Translation	1.10 to 1.30	6.0	13.0	19.8	5.5	25.3	ns	C _L = 30 pF R _L = 1 MΩ	Figures 1, 2
	V _{CC} (V) = 1.5	1.40 to 1.60	5.8	12.0	18.3	5.0	23.0			
		1.65 to 1.95	5.5	11.0	17.6	4.5	22.4			
		2.30 to 2.70	5.0	10.0	17.0	4.0	21.7			
		3.00 to 3.60	4.5	9.0	16.8	3.5	21.5			
t _{PHL}	Propagation Delay	1.0		15.0						
t _{PLH}	Output Translation	1.10 to 1.30	5.0	11.0	16.2	5.5	20.4	ns	C _L = 30 pF R _L = 1 MΩ	Figures 1, 2
	V _{CC} (V) = 1.8	1.40 to 1.60	4.5	10.0	14.7	4.0	19.2			
		1.65 to 1.95	4.0	9.0	13.9	3.5	18.5			
		2.30 to 2.70	3.5	8.0	13.3	3.0	17.9			
		3.00 to 3.60	3.5	8.0	13.1	2.5	17.6			
t _{PHL}	Propagation Delay	1.0		13.0						
t _{PLH}	Output Translation	1.10 to 1.30	4.0	8.0	12.7	3.5	15.9	ns	C _L = 30 pF R _L = 1 MΩ	Figures 1, 2
	V _{CC} (V) = 2.5	1.40 to 1.60	3.5	7.0	11.2	3.0	14.3			
		1.65 to 1.95	3.0	6.0	10.5	2.5	13.6			
		2.30 to 2.70	2.5	5.0	9.9	2.0	12.8			
		3.00 to 3.60	2.5	5.0	9.7	2.0	12.5			
t _{PHL}	Propagation Delay	1.0		12.0						
t _{PLH}	Output Translation	1.10 to 1.30	3.0	8.0	11.7	2.0	15.0	ns	C _L = 30 pF R _L = 1 MΩ	Figures 1, 2
	V _{CC} (V) = 3.3	1.40 to 1.60	2.5	7.0	9.8	1.5	12.2			
		1.65 to 1.95	2.0	6.0	8.9	1.0	11.5			
		2.30 to 2.70	1.5	5.0	8.3	1.0	10.7			
		3.00 to 3.60	1.5	5.0	8.1	1.0	10.4			
C _{IN}	Input Capacitance	0		2.0				pF		
C _{OUT}	Output Capacitance	0		4.0				pF		
C _{PD}	Power Dissipation Capacitance	V _{CC} /V _{CC1} = (1.0 to 3.60)		8.0				pF	V _I = 0V or V _{CC1} f = 10 MHz V _{CC} /V _{CC1} = 3.6	

Translator Power Up Sequence Recommendations

To insure that the system does not experience unnecessary I_{CC} current draw, bus contention or oscillations during power up, the following guidelines should be adhered to. This device is designed with the Output pin(s) is supplied by V_{CC} and the Input pin(s) is supplied by V_{CC1}. Therefore the first recommendation is to begin by powering up the input side of the device, V_{CC1}. The Input pin(s) should be ramped with or ahead of V_{CC1} or held LOW. This will guard against bus contentions and oscillations as all Inputs and

the Input V_{CC1} will be powered at the same time. The Output V_{CC} can then be powered to the voltage level that the device will be used to translate to. The Output pin(s) will then translate to logic levels dictated by the Output V_{CC} levels.

Upon completion of these steps the device can then be configured for the users desired operation. Following these steps will help to prevent possible damage to the translator device as well as other system components.

AC Loading and Waveforms

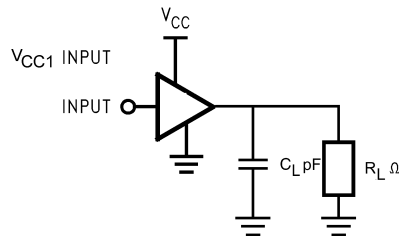

FIGURE 1. AC Test Circuit

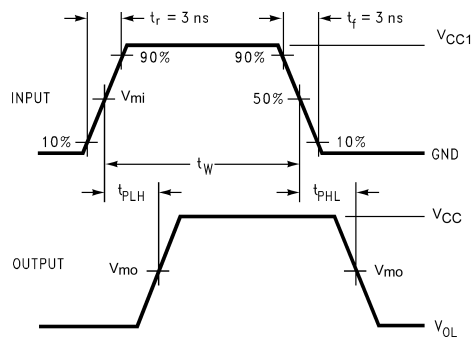

FIGURE 2. Waveform for Inverting and Non-Inverting Functions

Symbol	V_{CC}					
	$3.3V \pm 0.3V$	$2.5V \pm 0.2V$	$1.8V \pm 0.15V$	$1.5V \pm 0.10V$	$1.2V \pm 0.10V$	$1.0V$
V_{mi}	1.5V	$V_{CC1}/2$	$V_{CC1}/2$	$V_{CC1}/2$	$V_{CC1}/2$	$V_{CC1}/2$
V_{mo}	1.5V	$V_{CC}/2$	$V_{CC}/2$	$V_{CC}/2$	$V_{CC}/2$	$V_{CC}/2$

Tape and Reel Specification (Continued)

TAPE FORMAT for MicroPak

Package Designator	Tape Section	Number Cavities	Cavity Status	Cover Tape Status
L6X	Leader (Start End)	125 (typ)	Empty	Sealed
	Carrier	5000	Filled	Sealed
	Trailer (Hub End)	75 (typ)	Empty	Sealed

TAPE DIMENSIONS inches (millimeters)

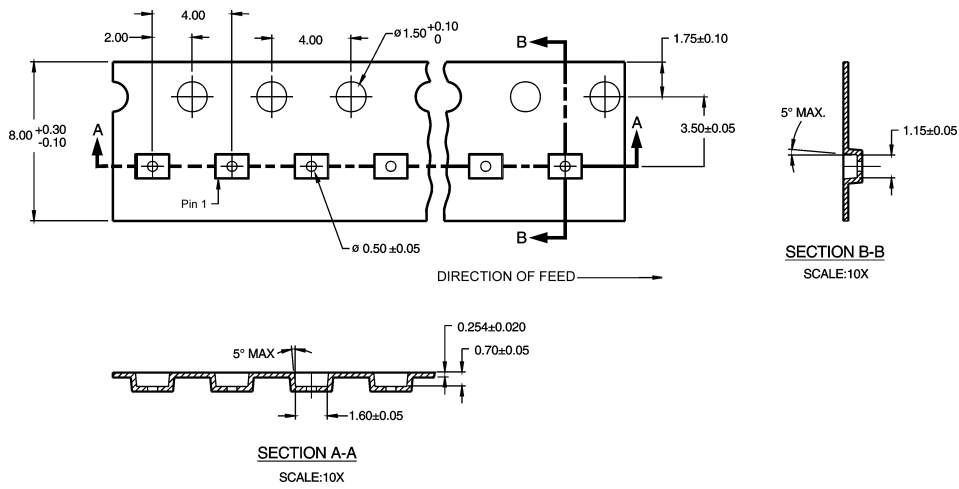

REEL DIMENSIONS inches (millimeters)

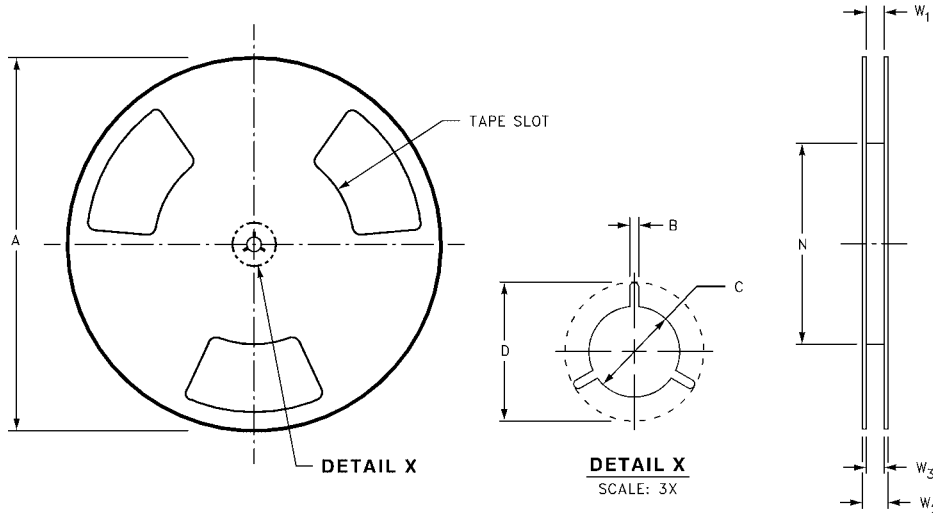

Tape Size	A	B	C	D	N	W1	W2	W3
8 mm	7.0 (177.8)	0.059 (1.50)	0.512 (13.00)	0.795 (20.20)	2.165 (55.00)	$0.331 + 0.059/-0.000$ (8.40 + 1.50/-0.00)	0.567 (14.40)	$W1 + 0.078/-0.039$ (W1 + 2.00/-1.00)

Physical Dimensions inches (millimeters) unless otherwise noted

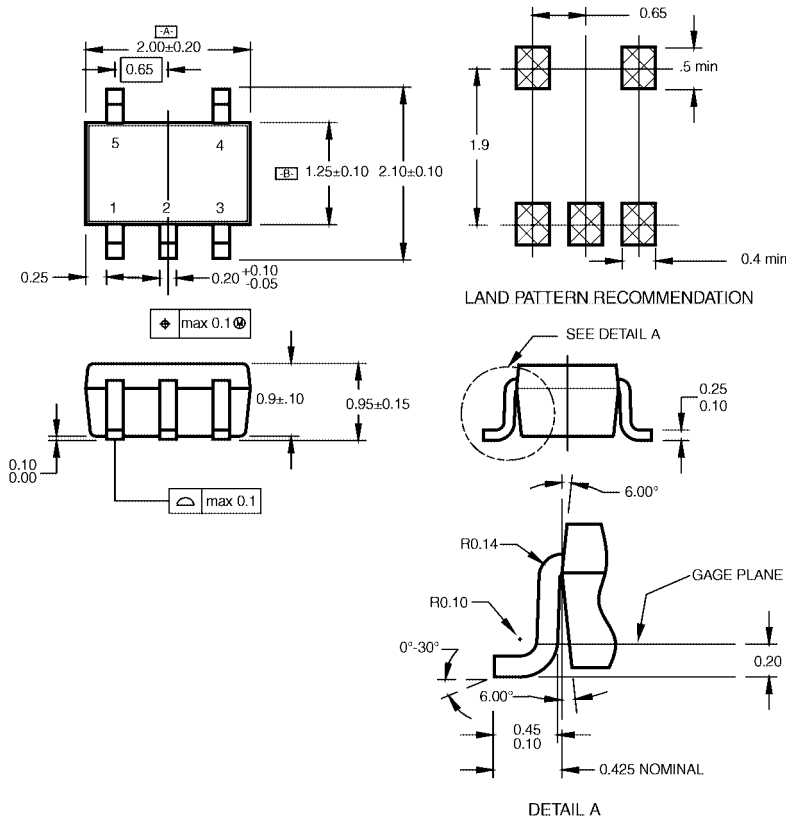

NOTES:
 A. CONFORMS TO EIAJ REGISTERED OUTLINE DRAWING SC88A.
 B. DIMENSIONS DO NOT INCLUDE BURRS OR MOLD FLASH.
 C. DIMENSIONS ARE IN MILLIMETERS.

MAA05ARevC

**5-Lead SC70, EIAJ SC-88a, 1.25mm Wide
 Package Number MAA05A**

Physical Dimensions inches (millimeters) unless otherwise noted (Continued)

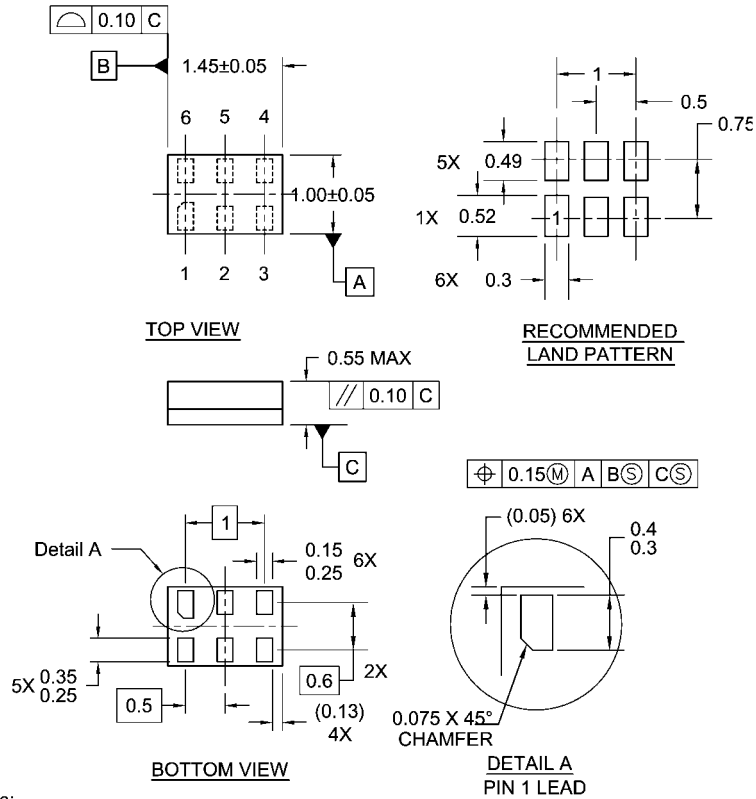

- Notes:
1. JEDEC PACKAGE REGISTRATION IS ANTICIPATED
 2. DIMENSIONS ARE IN MILLIMETERS
 3. DRAWING CONFORMS TO ASME Y14.5M-1994

MAC06ARevB

**6-Lead MicroPak, 1.0mm Wide
Package Number MAC06A**

Fairchild does not assume any responsibility for use of any circuitry described, no circuit patent licenses are implied and Fairchild reserves the right at any time without notice to change said circuitry and specifications.

LIFE SUPPORT POLICY

FAIRCHILD'S PRODUCTS ARE NOT AUTHORIZED FOR USE AS CRITICAL COMPONENTS IN LIFE SUPPORT DEVICES OR SYSTEMS WITHOUT THE EXPRESS WRITTEN APPROVAL OF THE PRESIDENT OF FAIRCHILD SEMICONDUCTOR CORPORATION. As used herein:

1. Life support devices or systems are devices or systems which, (a) are intended for surgical implant into the body, or (b) support or sustain life, and (c) whose failure to perform when properly used in accordance with instructions for use provided in the labeling, can be reasonably expected to result in a significant injury to the user.
2. A critical component in any component of a life support device or system whose failure to perform can be reasonably expected to cause the failure of the life support device or system, or to affect its safety or effectiveness.

www.fairchildsemi.com