



PRELIMINARY INFORMATION

**ICS548-05A
MP3 Audio Clock**

Description

The ICS548-05 is a low cost, low jitter, high performance clock synthesizer designed to produce audio sampling rates for MP3 systems. Using ICS' patented analog/digital Phase-Locked Loop (PLL) techniques, the device uses an inexpensive 3.6864 MHz crystal or clock input to exactly produce all of the popular audio sampling frequencies. Power down modes allow the chip to be turned off completely, or the PLL and audio clock output to be turned off separately.

ICS manufactures the largest variety of multimedia clock synthesizers for all applications. Consult ICS to eliminate VCXOs, crystals and oscillators from your board.

Features

- Packaged in 16 pin TSSOP
- Ideal for Cirrus Logic's MP3 chips
- Replaces multiple oscillators
- 3.3V (will work down to 2.7V) or 5V operation
- Uses an inexpensive 3.6864 MHz crystal or clock input
- Supports 32 kHz, 44.1 kHz, 48 kHz, and 96 kHz audio sampling rates
- Provides 128fs and 256fs clocks
- Zero ppm synthesis error
- Includes Power Down features
- Advanced, low power, sub-micron CMOS process

Block Diagram

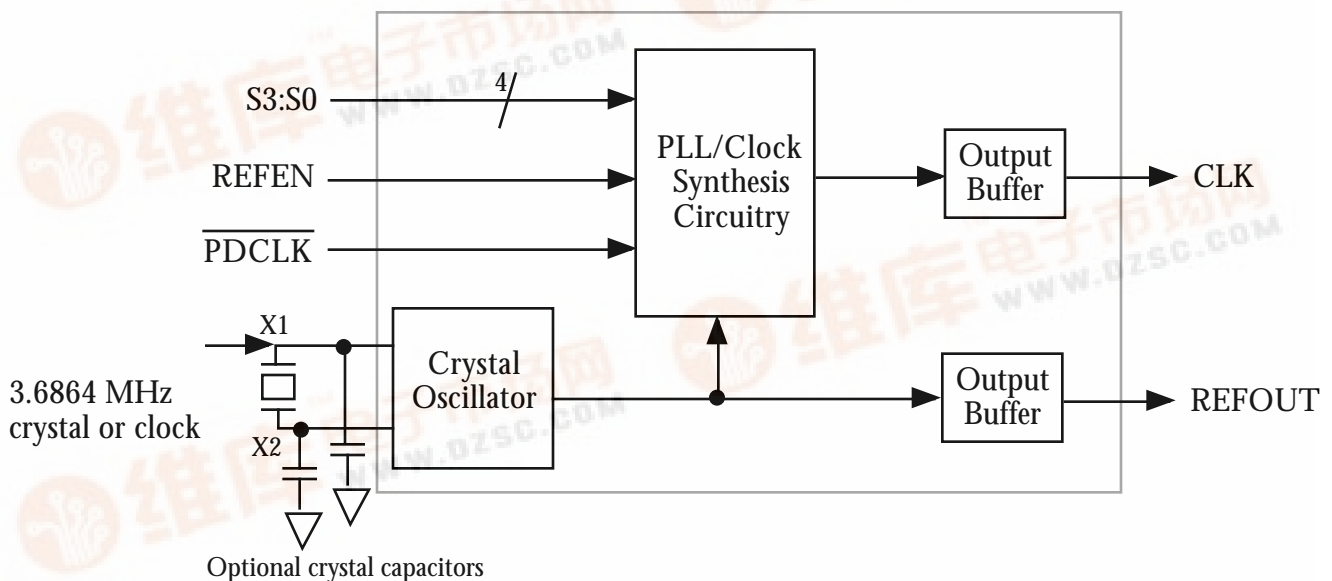



Pin Assignment

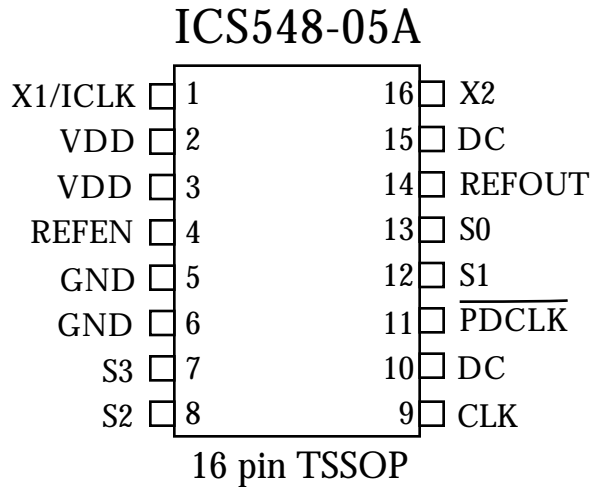

Output Clock Select Table

S3	S2	S1	S0	Input (MHz)	CLK (MHz)
Pin 7	Pin 8	Pin 12	Pin 13	Pins 1, (16)	Pin 9
0	0	1	0	3.6864	2.8224
0	0	1	1	3.6864	3.072
1	0	0	0	3.6864	4.096
1	0	0	1	3.6864	5.6448
1	0	1	0	3.6864	6.144
1	0	1	1	Turns off PLL and stops CLK low	
1	1	0	0	3.6864	8.192
1	1	0	1	3.6864	11.2896
1	1	1	0	3.6864	12.288
1	1	1	1	3.6864	2.048

Power Down Clock Select Table

REFEN	$\overline{\text{PDCLK}}$	Power Down Selection Mode
Pin 4	Pin 11	
0	0	The entire chip is off.
0	1	PLL and CLK output run, REFOUT low.
1	0	REFOUT running, PLL off, CLK low.
1	1	All running.

Key: 0 = connect directly to GND
1 = connect directly to VDD

Pin Descriptions

Number	Name	Type	Description
1	X1/ICLK	XI	Crystal connection. Connect to a 3.6864 MHz crystal, or input clock.
2, 3	VDD	P	Connect to +3.3V or +5V. All VDDs must be same.
4	REFEN	I	Reference Clock Enable. See above table.
5, 6	GND	P	Connect to ground.
7	S3	I	Frequency select pin 3. Determines clock outputs per table above.
8	S2	I	Frequency select pin 2. Determines clock outputs per table above.
9	CLK	O	Audio clock output set by status of S0-S3. See table above.
10, 15	DC	-	Don't Connect. Do not connect anything to these pins.
11	$\overline{\text{PDCLK}}$	I	Power Down Clock. See above table.
12	S1	I	Frequency select pin 1. Determines clock outputs per table above.
13	S0	I	Frequency select pin 0. Determines clock outputs per table above.
14	REFOUT	O	Buffered 3.6864 MHz oscillator output clock. Controlled by REFEN.
16	X2	XO	Crystal connection. Connect to a 3.6864 MHz crystal, or leave unconnected for clock.

Key: I = Input; O = output; P = power supply connection; XI, XO = crystal connections
The input pins S3:S0 lack pull-ups, so they cannot be left floating. Tie directly to VDD or GND. For a clock input, connect the input to X1, and leave X2 unconnected (floating).

**Electrical Specifications**

Parameter	Conditions	Minimum	Typical	Maximum	Units
ABSOLUTE MAXIMUM RATINGS (note 1)					
Supply voltage, VDD	Referenced to GND			7	V
Inputs and Clock Outputs	Referenced to GND	-0.5		VDD+0.5	V
Ambient Operating Temperature		0		70	°C
Soldering Temperature	Max of 10 seconds			260	°C
Storage temperature		-65		150	°C
DC CHARACTERISTICS (VDD = 3.3V unless noted)					
Core Operating Voltage, VDD		2.7		5.5	V
Input High Voltage, VIH, X1/ICLK pin	Clock input only	(VDD/2)+1	VDD/2		V
Input Low Voltage, VIL, X1/ICLK pin	Clock input only		VDD/2	(VDD/2)-1	V
Input High Voltage, VIH		2			V
Input Low Voltage, VIL				0.8	V
Output High Voltage, VOH	IOH=-12mA	2.4			V
Output Low Voltage, VOL	IOL=12mA			0.4	V
Output High Voltage, VOH, CMOS level	IOH=-4mA	VDD-0.4			V
Operating Supply Current, IDD	No Load		4		mA
Power Down Supply Current, IDDPD	No Load		5		µA
Short Circuit Current	CLK output		±50		mA
Input Capacitance	S0, S1, S2, S3, PDCLK		7		pF
Frequency synthesis error	All selections			0	ppm
AC CHARACTERISTICS (VDD = 3.3V unless noted)					
Input Crystal or Clock Frequency			3.6864		MHz
Output Clock Rise Time	0.8 to 2.0V			2	ns
Output Clock Fall Time	2.0 to 0.8V			2	ns
Output Clock Duty Cycle	At VDD/2	40	50	60	%
Start-up Time	VDD=3V to CLK stable			10	ms
Maximum Absolute Jitter, short term			±250		ps
One sigma jitter			70		ps

Note: 1. Stresses beyond those listed under Absolute Maximum Ratings could cause permanent damage to the device. Prolonged exposure to levels above the operating limits but below the Absolute Maximums may affect device reliability.

External Components/ Application Information

The ICS548-05 requires a minimum number of external components for proper operation. A decoupling capacitor of 0.01µF should be connected between VDD and GND on pins 3 and 5, as close to the ICS548-05 as possible. Other VDDs can be connected to pin 3. A series termination resistor of 33 Ω may be used for each clock output. If REFOUT is not used, then REFEN should be connected to ground. The input crystal must be connected as close to the chip as possible. The input crystal should be fundamental mode, parallel resonant. For exact accuracy of the output frequencies, the crystal can be tuned with two identical capacitors to ground, as shown on the block diagram. The value of these two crystal caps should be equal to $(C_L - 6) * 2$, where C_L is the crystal load (or correlation) capacitance.

**Package Outline and Package Dimensions**

(For current dimensional specifications, see JEDEC publication no. 95.)

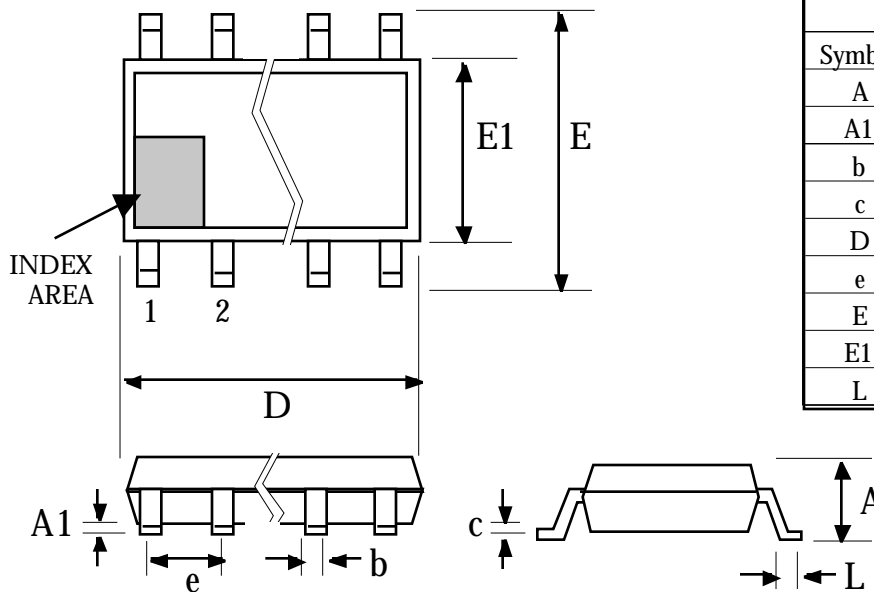
16 pin TSSOP

Symbol	Inches		Millimeters	
	Min	Max	Min	Max
A	--	0.047	--	1.19
A1	0.002	0.006	0.05	0.15
b	0.007	0.012	0.18	0.30
c	0.0035	0.008	0.09	0.20
D	0.193	0.201	4.90	5.11
e	.025 BSC		0.65 BSC	
E	.252 BSC		6.40 BSC	
E1	0.169	0.177	4.29	4.50
L	0.018	0.030	0.46	0.76

Ordering Information

Part/Order Number	Marking	Shipping packaging	Package	Temperature
ICS548G-05	548G-05	tubes	16 pin TSSOP	0-70 °C
ICS548G-05T	548G-05	tape and reel	16 pin TSSOP	0-70 °C

While the information presented herein has been checked for both accuracy and reliability, Integrated Circuit Systems, Incorporated (ICS) assumes no responsibility for either its use or for the infringement of any patents or other rights of third parties, which would result from its use. No other circuits, patents, or licenses are implied. This product is intended for use in normal commercial applications. Any other applications such as those requiring extended temperature range, high reliability, or other extraordinary environmental requirements are not recommended without additional processing by ICS. ICS reserves the right to change any circuitry or specifications without notice. ICS does not authorize or warrant any ICS product for use in life support devices or critical medical instruments.