

Product Information

ISO 9001 CERTIFIED

TAG-1030 5.725 to 5.825 GHz GaAs MMIC U-NII Band Power Amplifier

Features:

- ◆ 25 dBm Minimum Linear Output Power
- ◆ 20 dB Small Signal Gain
- ◆ 35 dBm 3rd Order Intercept Point
- ◆ Surface Mount Thermally Efficient Moly-Copper Package

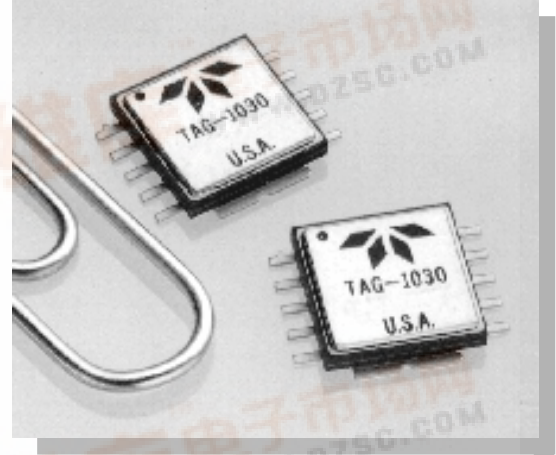

Product Description

The TAG-1030 GaAs MMIC power amplifier is designed to operate in the ETSI approved Unlicensed band of 5.725 to 5.825 GHz. It provides a minimum of 20 dB gain, a minimum of +25 dBm linear output power when measured at 1 dB GCP, and has an IP3 of +35 dBm. It is housed in a thermally efficient moly-copper surface mount package and is capable of performing within typical commercial system operating temperature ranges.

Electrical Specifications (All Specifications at 25°C, $V_d = +7.0V$, $I_d = 500$ to 700 mA)

Parameter	Symbol	Frequency	Min	Max	Typical	Units
Small Signal Gain	S_{21}	5.7 to 5.9 GHz	20.0	-	23.0	dB
Input Return Loss	S_{11}	5.7 to 5.9 GHz	-	-	-10.0	dB
Reverse Isolation	S_{12}	5.7 to 5.9 GHz	-	-	52.0	dB
Output Power @ 1dB Gain Compression	P_{-1dB}	5.7 GHz	25.0	-	26.0	dBm
		5.8 GHz	25.0	-	26.3	dBm
		5.9 GHz	25.0	-	26.8	dBm
Temperature Coefficient of Gain	ΔS_{21}	5.7 to 5.9 GHz	-	-	-0.045	dB/°C

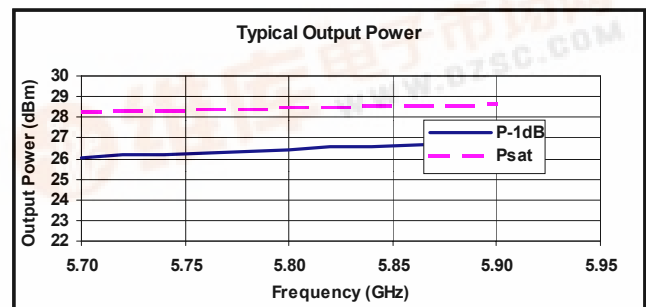
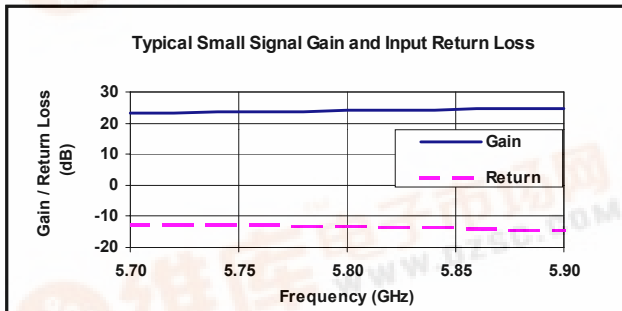

TAG-1030

5.725 to 5.825 GHz GaAs MMIC Power Amplifier for U-NII Applications

Package Outline

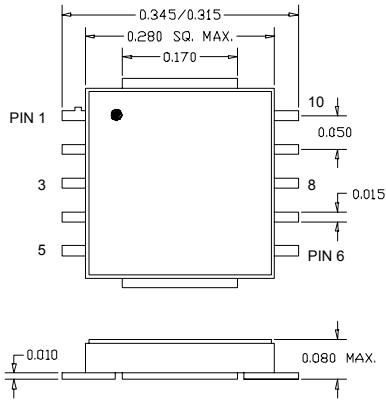

Pin 3: RF Input
Pin 5: V_g
Pin 8: RF Output
Pin 10: V_d

Tolerance: .XXX ± 0.005

Typical Biasing Configuration

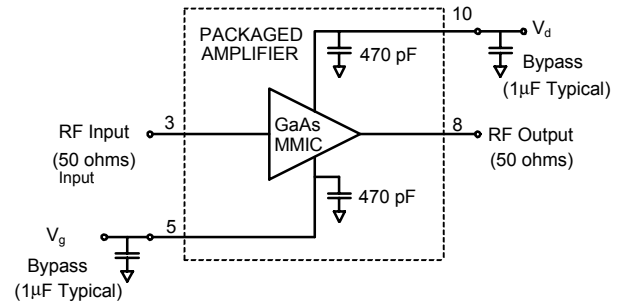

External Components Required:
Bypass Capacitors: 1 μ F, typical
50 Ohm microstrip interface

Evaluation Circuit

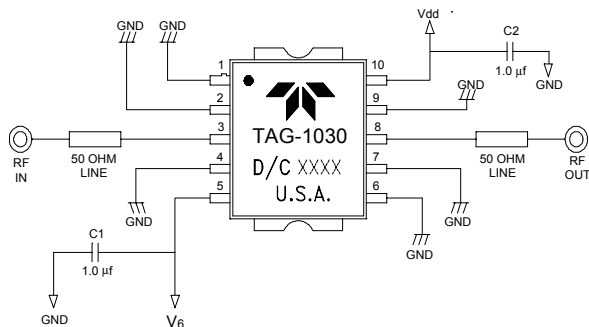

Evaluation Board

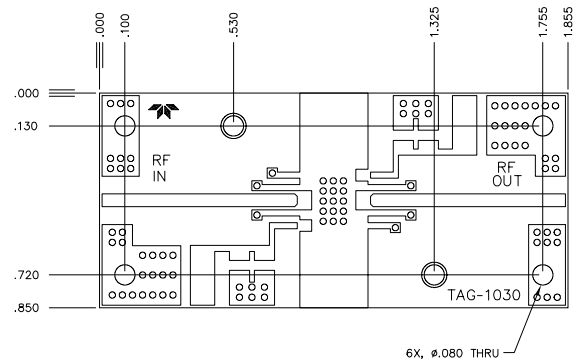

Notes

1. Dual bias supply required.
2. DC supply sequencing or protection circuitry not included. See Amplifier Biasing Procedure
3. A 360 pF DC supply line decoupling capacitor is included on both V_d and V_g lines. (See typical biasing configuration shown above).
4. The last fixture or circuit should incorporate additional bypass capacity (25 μ f) on the drain and gate bias terminals to prevent oscillations caused by feedback signals.
5. Supply (drain and gate) wire/leads should be as short as possible.
6. Close placement of external components to the power amplifier is essential for stability purposes.
7. TET recommends the unit be soldered to DC and RF ground for best results.
8. Pin numbers indicated on outline drawing are for user information only. Units are not labeled with pin numbers.
9. MASK drawing for circuit board available on the Teledyne Wireless website at www.teledynewireless.com.

Teledyne reserves the right to make changes without further notice to any specification herein. "Typical" parameters can and do vary.