

Product Information

ISO 9001 CERTIFIED

TAG-1035 5.8 to 6.4 GHz GaAs MMIC VSAT (C-BAND) Power Amplifier

Features

- ◆ 26 dBm Minimum Linear Output Power
- ◆ 18 dB Small Signal Gain
- ◆ Thermally Efficient Moly-Copper Package
- ◆ C-Band VSAT Application

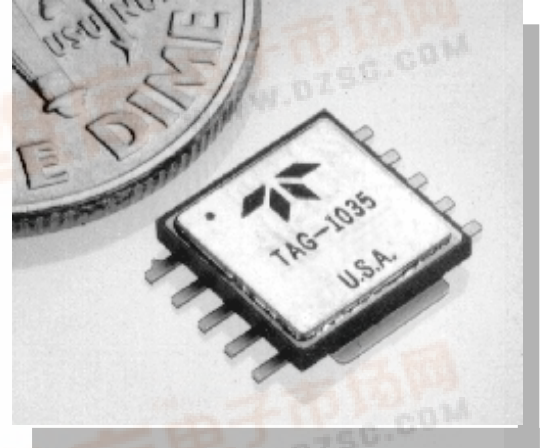

Product Description

The TAG-1035 amplifier is ideally suited to provide linear power amplification for C-Band VSAT satellite applications. Typical uses are as a driver amplifier for VSAT power modules and C-Band SATCOM transmitters. The amplifier provides a minimum of +26 dBm linear power output. Typical DC power consumption is 600 mA at +7.0V and 10 mA at -1.0V.

Electrical Specifications (All Specifications at 25°C, $V_d = +7.0V$, $I_d = 600\text{ mA}$)

Parameter	Symbol	Frequency	Min	Max	Typical	Units
Small Signal Gain	S_{21}	5.8 to 6.4 GHz	18	-	23	dB
Input Return Loss	S_{11}	5.8 to 6.4 GHz	-	-	-10	dB
Reverse Isolation	S_{12}	5.8 to 6.4 GHz	30	-	48	dB
Output Power @ 1dB Gain Compression	P_{-1dB}	5.8 GHz	26	-	27.5	dBm
		6.1 GHz	28	-	29.2	dBm
Temperature Coefficient of Gain	ΔS_{21}	6.4 GHz	28	-	29.2	dBm
		5.8 to 6.4 GHz	-	-	-0.045	dB/°C

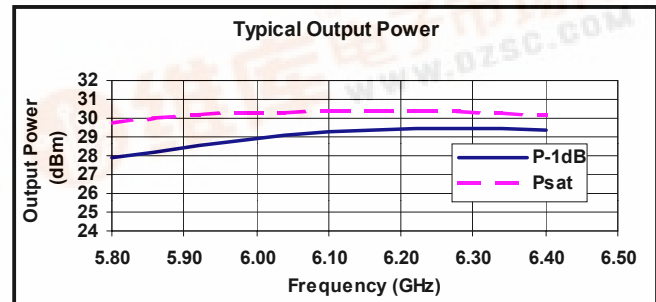
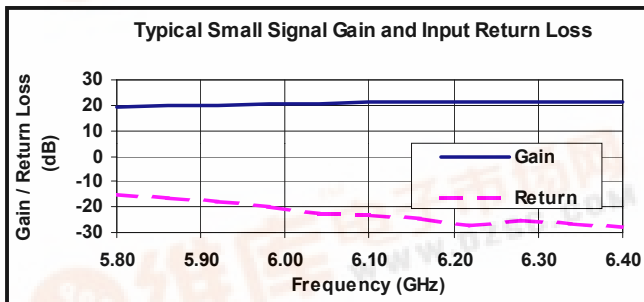

TAG-1035

5.8 to 6.4 GHz GaAs MMIC Power Amplifier for VSAT (C-Band) Applications

Package Outline

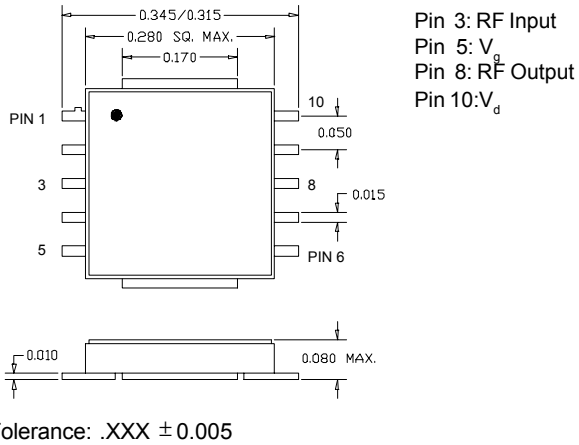

Typical Biasing Configuration

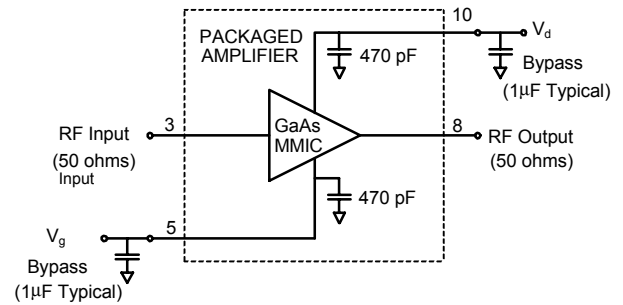

Evaluation Circuit

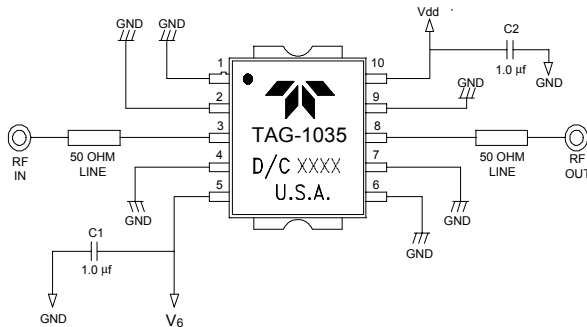

Evaluation Board

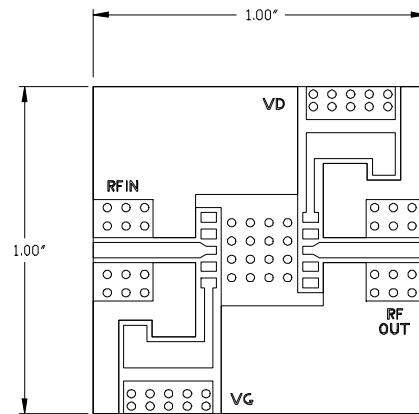

Notes

1. Dual bias supply required.
2. DC supply sequencing or protection circuitry not included. See Amplifier Biasing Procedure
3. A 360 pF DC supply line decoupling capacitor is included on both V_d and V_g lines. (See typical biasing configuration shown above).
4. The last fixture or circuit should incorporate additional bypass capacity (25ufd) on the drain and gate bias terminals to prevent oscillations caused by feedback signals.
5. Supply (drain and gate) wire/leads should be as short as possible.
6. Close placement of external components to the power amplifier is essential for stability purposes.
7. TET recommends the unit be soldered to DC and RF ground for best results.
8. Pin numbers indicated on outline drawing are for user information only. Units are not labeled with pin numbers.
9. MASK drawing for circuit board available on the Teledyne Wireless website at www.teledynewireless.com.

Teledyne reserves the right to make changes without further notice to any specification herein. "Typical" parameters can and do vary.