



Stereo Headphone Power Amplifier

Features

- Class AB amplifier
- High performance
- High signal-to-noise ratio
- Low distortion
- Low power consumption
- Large output voltage swing
- Excellent power supply ripple rejection
- 3.0V to 7.0V supply voltage range
- Surface-Mount package-SOP 8

Applications

- CD-ROM
- DVD-ROM
- CD-R/W
- MP3
- Portable Stereo
- Earphone for cellular phone

General Description

The G1401 is a stereo audio power amplifier housed in a 8-pin SOP package capable of delivering 135mW of continuous power per channel into 16Ω loads.

Amplifier gain is externally configured by means of two resistors per input channel.

The G1401 is a dual channel, low voltage, low power, performance OP amps that can be designed into a wide range of headphone driving applications, at an economical price.

Ordering Information

PART	TEMP. RANGE	PIN-PACKAGE
G1401P1	0°C to +70°C	8 SOP

Pin Configuration

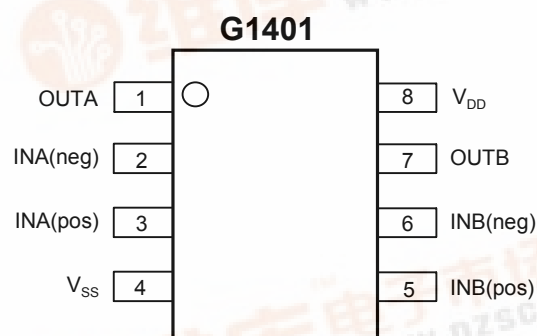

Pinning

SYMBOL	PIN	DESCRIPTION
OUTA	1	output A
INA(neg)	2	inverting input A
INA(pos)	3	non-inverting input A
V _{SS}	4	negative supply
INB(pos)	5	non-inverting input B
INB(neg)	6	inverting input B
OUTB	7	output B
V _{DD}	8	positive supply



Block Diagram

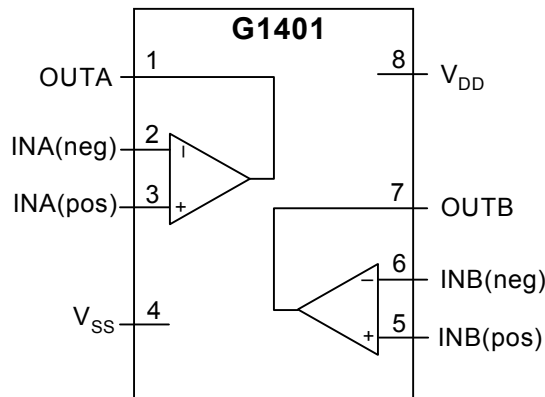

Absolute Maximum Ratings (Note1)

SYMBOL	PARAMETER	CONDITIONS	MIN.	MAX.	UNIT
V_{DD}	Supply voltage		0	7.0	V
T_{stg}	Storage temperature		-65	+150	°C
T_{amb}	Operating ambient temperature		0	+70	°C
ESD	ESD voltage	HBM	-	2	KV

Notes:

1. Absolute Maximum Ratings are limits beyond which damage to the device may occur.

Thermal Characteristics

SYMBOL	PARAMETER	VALUE	UNIT
$R_{th\ j-a}$	Thermal resistance from junction to ambient in free air SO8	210	°C/W

Test and Application Information

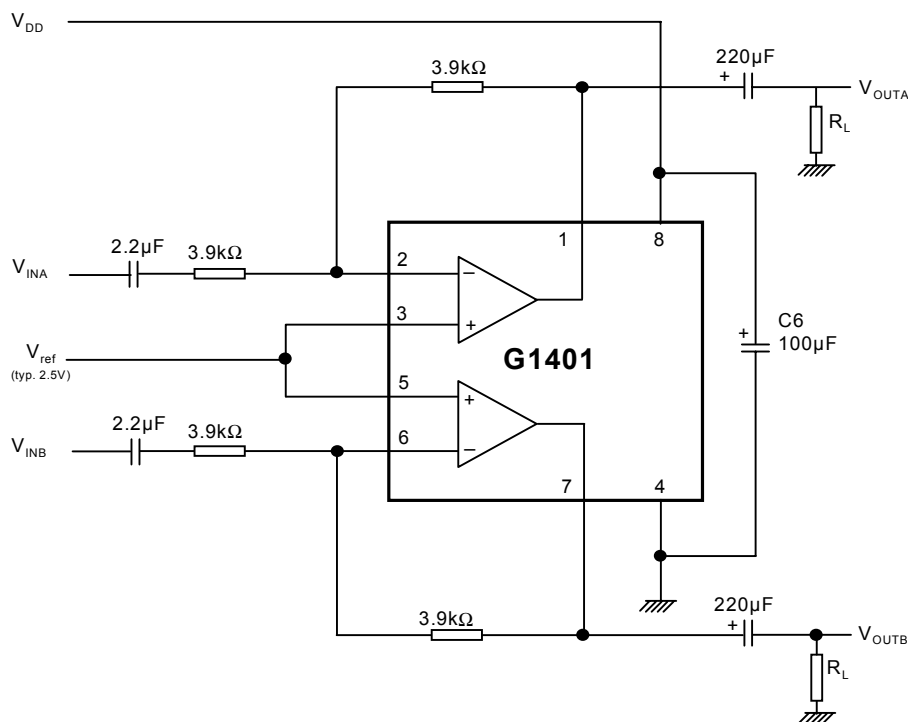

Fig.1 Measurement circuit for inverting application

**Electrical Characteristics** $V_{DD} = 5V$; $V_{SS} = 0V$; $T_{amb} = 25^{\circ}C$; $f_i = 1kHz$; $R_L = 32\Omega$; unless otherwise specified.

SYMBOL	PARAMETER	CONDITIONS	MIN.	TYP.	MAX.	UNIT
Supplies						
V_{DD}	Supply voltage		3.0	5.0	7.0	V
	Single		3.0	5.0	7.0	V
	Dual		1.5	2.5	3.5	V
V_{SS}	Negative supply voltage		-1.5	-2.5	-3.5	V
I_{DD}	Supply current	no load	-	3.0	5.5	mA
P_{tot}	Total power dissipation	no load	-	15	28	mW
DC Characteristics						
$V_{I(OS)}$	Input offset voltage		-15	-	15	mV
V_{CM}	Common mode voltage		0	-	4.0	V
CMRR	Common-Mode Rejection Ratio	$V_{CM} = 0V$ to $5V$	40	60		dB
G_V	Open-loop voltage gain	$R_L = 5k\Omega$	70	90	-	dB
I_O	Maximum output current	THD<0.1%	-	100	-	mA
R_O	Output resistance	open-loop $R_L = 20\Omega$	-	1.78	-	Ω
V_O	Output voltage swing	$R_L = 32\Omega$ note 1	1.0	-	4.0	V
		$R_L = 5k\Omega$ note 1	0.1	-	4.9	V
PSRR	Power supply rejection ratio	$f_i = 1kHz$; $V_{ripple(peak)} = 1V$	50	62	-	dB
α_{cs}	Channel separation		-	70	-	dB
AC Characteristics						
THD	Total harmonic distortion	note 2	-	< 0.1	-	%
		$R_L = 5k\Omega$ note 2	-	< 0.1	-	%
f_G	Unity gain frequency	open-loop; $R_L = 5k\Omega$	2.5	3.7	5.0	MHz
P_O	Maximum output power	note 1; $R_L = 16\Omega$	-	135	-	mW
B	Power bandwidth	unity gain inverting	-	30	-	kHz

Notes:

1. Values are proportional to V_{DD} ; THD < 0.1%
2. $V_{DD} = 5.0V$; $V_{O(P-P)} = 4.0V$ (at 0 dB)



Output Swing Range Voltage Figure

Test Condition : $T_A = 25^\circ\text{C}$, $A_V = -1$

$V_+ = 2.5\text{V}$, $V_- = -2.5\text{V}$, $R_L = 5\text{k}\Omega$

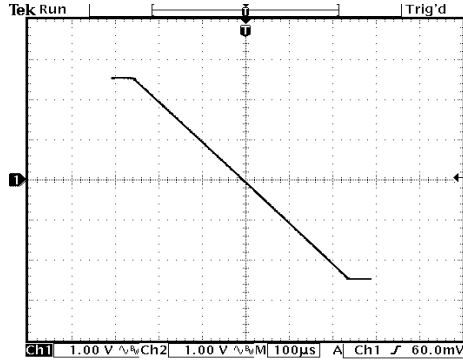

$V_+ = 1.5\text{V}$, $V_- = -1.5\text{V}$, $R_L = 5\text{k}\Omega$

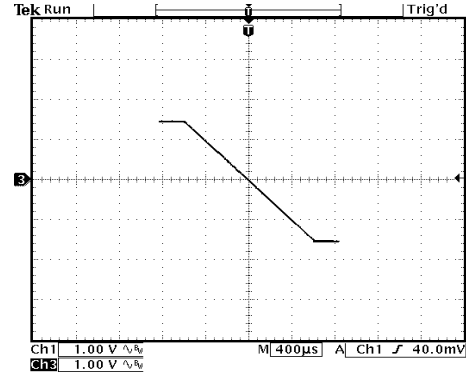

$V_+ = 2.5\text{V}$, $V_- = -2.5\text{V}$, $R_L = 2\text{k}\Omega$

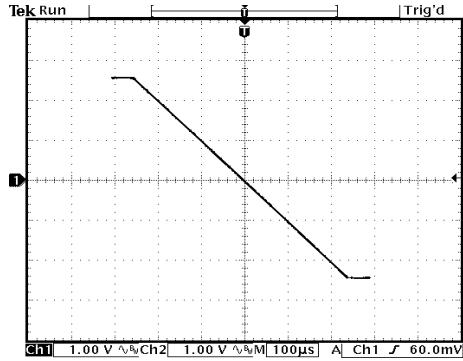

$V_+ = 1.5\text{V}$, $V_- = -1.5\text{V}$, $R_L = 2\text{k}\Omega$

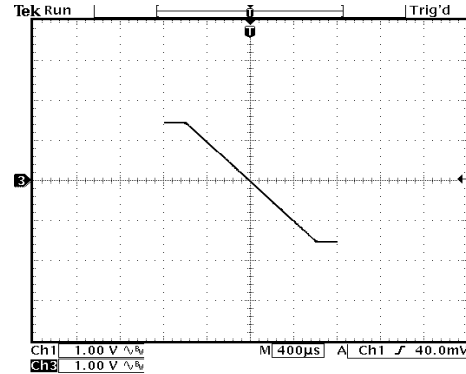

$V_+ = 2.5\text{V}$, $V_- = -2.5\text{V}$, $R_L = 32\Omega$

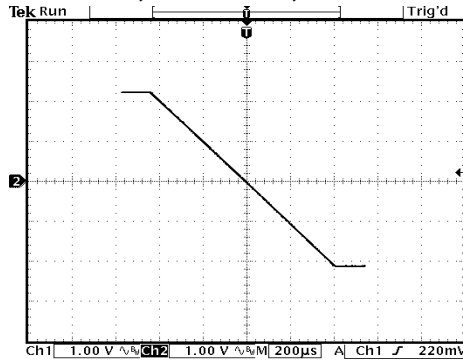

$V_+ = 1.5\text{V}$, $V_- = -1.5\text{V}$, $R_L = 32\Omega$

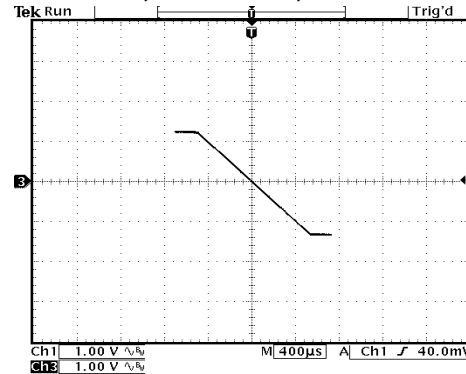

$V_+ = 2.5\text{V}$, $V_- = -2.5\text{V}$, $R_L = 16\Omega$

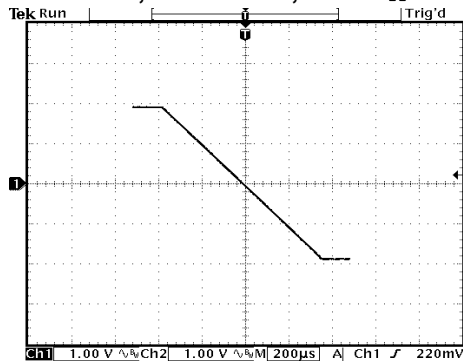

$V_+ = 1.5\text{V}$, $V_- = -1.5\text{V}$, $R_L = 16\Omega$

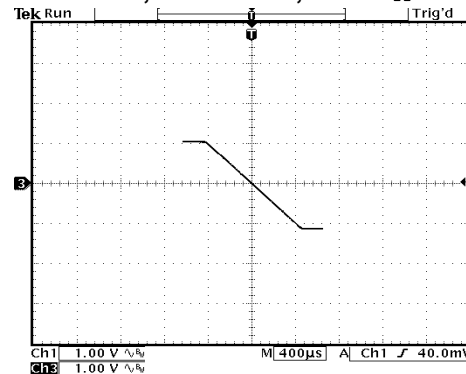



Input Common Mode Voltage Range Figure

Test Condition : $T_A = 25^\circ\text{C}$, $A_V = 1$

$V_+ = 5\text{V}$, $V_- = 0\text{V}$, $R_L = 5\text{k}\Omega$

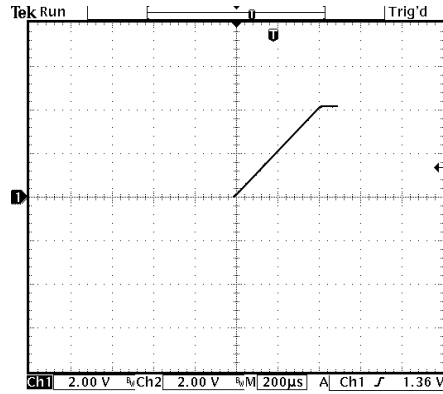
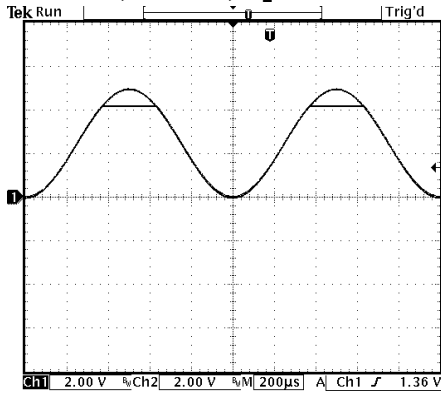

$V_+ = 3\text{V}$, $V_- = 0\text{V}$, $R_L = 5\text{k}\Omega$

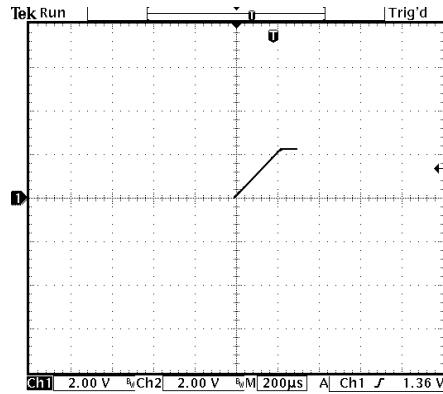
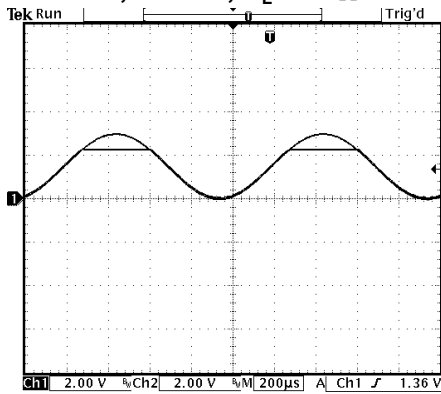

Test Condition: $V_s = \pm 2.5\text{V}$, $T_A = 25^\circ\text{C}$

Open-Loop Gain & Phase vs. Frequency

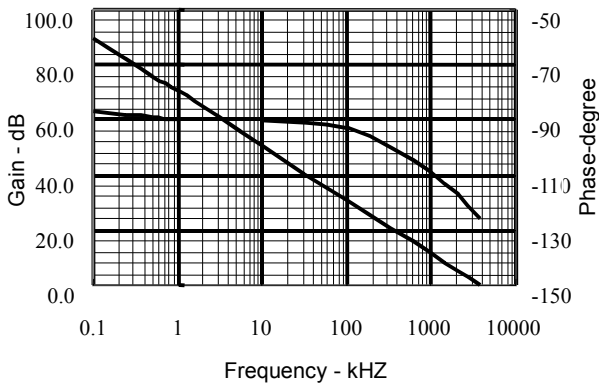

Test Condition: $V_s = \pm 2.5\text{V}$, $T_A = 25^\circ\text{C}$

PSRR

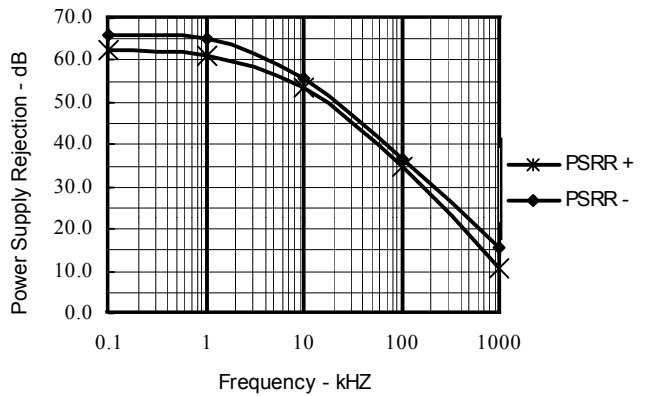



Package Information

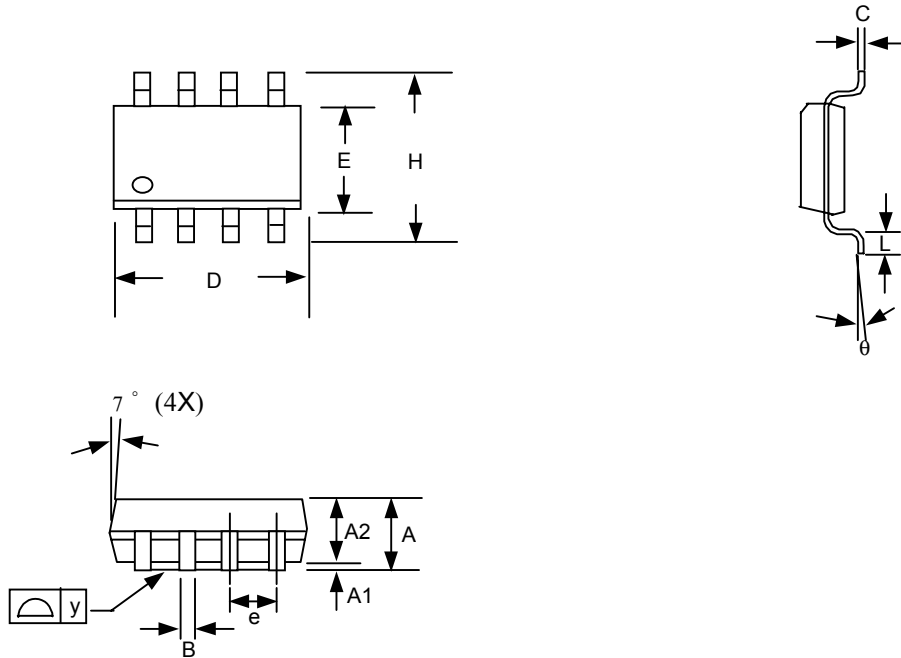

1. Package body sizes exclude mold flash and gate burrs
2. Dimension L is measured in gage plane
3. Tolerance 0.10mm unless otherwise specified
4. Controlling dimension is millimeter converted inch dimensions are not necessarily exact.

SYMBOL	DIMENSION IN MM			DIMENSION IN INCH		
	MIN.	NOM.	MAX.	MIN.	NOM.	MAX.
A	1.35	1.60	1.75	0.053	0.063	0.069
A1	0.10	----	0.25	0.004	----	0.010
A2	----	1.45	----	----	0.057	----
B	0.33	----	0.51	0.013	----	0.020
C	0.19	----	0.25	0.007	----	0.010
D	4.80	----	5.00	0.189	----	0.197
E	3.80	----	4.00	0.150	----	0.157
e	----	1.27	----	----	0.050	----
H	5.80	----	6.20	0.228	----	0.244
L	0.40	----	1.27	0.016	----	0.050
y	----	----	0.10	----	----	0.004
θ	0°	----	8°	0°	----	8°

Taping Specification

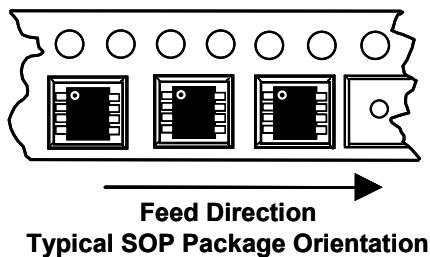

GMT Inc. does not assume any responsibility for use of any circuitry described, no circuit patent licenses are implied and GMT Inc. reserves the right at any time without notice to change said circuitry and specifications.