

POWER SUPPLY OUTPUT SUPERVISORY CIRCUIT

DESCRIPTION

This monolithic integrated circuit contains all the functions necessary to monitor and control the output of a sophisticated power supply system. Over-voltage (O.V.) sensing with provision to trigger an external SCR "crowbar" shutdown; an under-voltage (U.V.) circuit which can be used to monitor either the output or to sample the input line voltage; and a third op amp/comparator usable for current sensing (C.L.) are all included in this IC, together with an independent, accurate reference generator.

Both over and under-voltage sensing circuits can be externally programmed for minimum time duration of fault before triggering. All functions contain open collector outputs which can be used independently or wire-ORed together; and although the SCR trigger is directly connected only to the over-voltage sensing circuit, it may be optionally activated by any of the other outputs, or from an external signal. The O.V. circuit also includes an optional latch and external reset capability.

The current sense circuit may be used with external compensation as a linear amplifier or as a high gain comparator. Although nominally set for zero input offset, a fixed threshold may be added with an external resistor. Instead of current limiting, this circuit may also be used as an additional voltage monitor.

The reference generator circuit is internally trimmed to eliminate the need for external potentiometers and the entire circuit may be powered directly from either the output being monitored or from a separate bias voltage.

FEATURES

- Over-voltage, under-voltage, and current sensing circuits all included
- Reference voltage trimmed to 1% accuracy
- SCR "Crowbar" drive of 300mA
- Programmable time delays
- Open-collector outputs and remote activation capability
- Total standby current less than 10mA

HIGH RELIABILITY FEATURES - SG1543

- ◆ Available to MIL-STD-883 and DESC SMD
- ◆ LMI level "S" processing available

BLOCK DIAGRAM

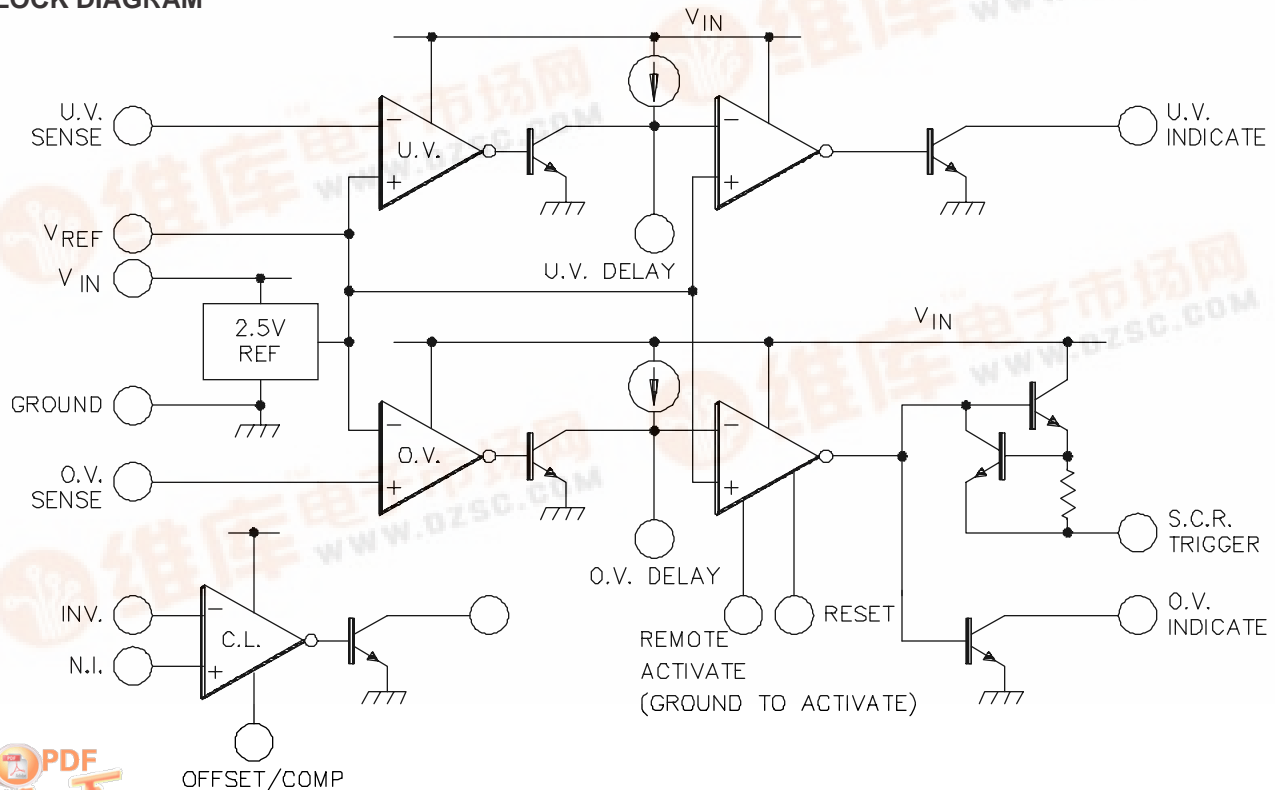

SG1543/SG2543/SG3543

ABSOLUTE MAXIMUM RATINGS (Note 1)

Input Supply Voltage (+V _{IN}).....	40V	Indicator Output Sink Current	50mA
Sense Inputs	+V _{IN}	Operating Junction Temperature	
SCR Trigger Current (Note 2)	300mA	Hermetic (J, L Packages)	150°C
Indicator Output Voltage	40V	Plastic (N, DW Packages)	150°C
		Storage Temperature Range	-65°C to 150°C

Note 1. Values beyond which damage may occur.

Note 2. At higher input voltages, a dissipation limiting resistor, R_G, is required. See Figure 1.

THERMAL DATA

J Package:

Thermal Resistance-Junction to Case, θ _{JC}	30°C/W
Thermal Resistance-Junction to Ambient, θ _{JA}	80°C/W

N Package:

Thermal Resistance-Junction to Case, θ _{JC}	40°C/W
Thermal Resistance-Junction to Ambient, θ _{JA}	65°C/W

DW Package:

Thermal Resistance-Junction to Case, θ _{JC}	40°C/W
Thermal Resistance-Junction to Ambient, θ _{JA}	95°C/W

L Package:

Thermal Resistance-Junction to Case, θ _{JC}	35°C/W
Thermal Resistance-Junction to Ambient, θ _{JA}	120°C/W

Note A. Junction Temperature Calculation: $T_J = T_A + (P_D \times \theta_{JA})$.

Note B. The above numbers for θ_{JC} are maximums for the limiting thermal resistance of the package in a standard mounting configuration. The θ_{JA} numbers are meant to be guidelines for the thermal performance of the device/pc-board system. All of the above assume no ambient airflow.

RECOMMENDED OPERATING CONDITIONS (Note 3)

Input Supply Voltage (+V _{IN})	4.7V to 40V	Delay Timing Capacitor (Note 4)	0 to 1μF
Current Limit Common Mode		Operating Ambient Temperature Range	
Input Voltage Range	0V to +V _{IN} -3V	SG1543	-55°C to 125°C
Reference Load Current	0 to 10mA	SG2543	-25°C to 85°C
Indicator Output Voltage	4.7V to 40V	SG3543	0°C to 70°C
Indicator Output Current	0 to 10mA		

Note 3: Range over which the device is functional.

Note 4: Larger value capacitor may be used with peak current limiting. See Figure 7.

ELECTRICAL CHARACTERISTICS

(Unless otherwise specified, these specifications apply over the operating ambient temperatures for SG1543 with -55°C ≤ T_A ≤ 125°C, SG2543 with -25°C ≤ T_A ≤ 85°C, SG3543 with 0°C ≤ T_A ≤ 70°C, and +V_{IN} = 10V. Indicator outputs have 2KΩ pull-up resistor. Low duty cycle testing techniques are used which maintains junction and case temperatures equal to the ambient temperature.)

Parameter	Test Conditions	SG1543/2543			SG3543			Units
		Min.	Typ.	Max.	Min.	Typ.	Max.	
Supply Section								
Input Voltage Range	T _J = 25°C to T _{MAX}	4.5		40	4.5		40	V
		4.7		40	4.7		40	V
Supply Current	+V _{IN} = 40V, Outputs open, T _J = 25°C		7	10		7	10	mA
Reference Section								
Output Voltage	T _J = 25°C	2.48	2.50	2.52	2.45	2.50	2.55	V
		2.45		2.55	2.40		2.60	V
Line Regulation	+V _{IN} = 5 to 30V		1	5		1	5	mV
Load Regulation	I _{REF} = 0 to 10mA		1	10		1	10	mV
Short Circuit Current	V _{REF} = 0V	12	25	40	12	25	40	mA
Temperature Stability			.005			.005		%/°C

ELECTRICAL CHARACTERISTICS (continued)

Parameter	Test Conditions	SG1543/2543			SG3543			Units
		Min.	Typ.	Max.	Min.	Typ.	Max.	
Comparator Section								
Input Threshold (Note 5)	$T_J = 25^\circ\text{C}$	2.45	2.50	2.55	2.40	2.50	2.60	V
		2.40		2.60	2.35		2.65	V
Input Hysteresis			25			25		mV
Input Bias Current	Sense input = 0V		0.3	1.0		0.3	1.0	μA
Delay Saturation			0.2	0.5		0.2	0.5	V
Delay High Level			6	8		6	8	V
Delay Charging Current	$V_D = 0\text{V}$	200	250	300	200	250	300	μA
Indicate Saturation	$I_L = 10\text{mA}$		0.2	0.5		0.2	0.5	V
Indicate Leakage	$V_{IND} = 40\text{V}$.01	1.0		0.1	1.0	μA
Propagation Delay	$V_{O.V. INPUT} = 2.7\text{V}, V_{U.V. INPUT} = 2.3\text{V}, T_J = 25^\circ\text{C}$							
	$C_D = 0$		400			400		ns
	$C_D = 1\mu\text{F}$		10			10		ms
SCR Trigger Section								
Peak Output Current	$+V_{IN} = 5\text{V}, R_G = 0, V_O = 0$	100	200	400	100	200	400	mA
Peak Output Voltage	$+V_{IN} = 15\text{V}, I_O = 100\text{mA}$	12	13		12	13		V
Output Off Voltage	$+V_{IN} = 40\text{V}, R_L = 1\text{k}\Omega$		0	0.1		0	0.1	V
Remote Activate Current	REM. ACT. pin = Gnd		0.4	0.8		0.4	0.8	mA
Remote Activate Voltage	REM. ACT pin open		2	6		2	6	V
Reset Current	RESET pin = Gnd, REM. ACT. = Gnd		0.4	0.8		0.4	0.8	mA
Reset Voltage	RESET pin open, REM. ACT. = Gnd		2	6		2	6	V
Output Current Rise Time	$R_L = 50\Omega, T_J = 25^\circ\text{C}, C_D = 0$		400			400		mA/ μs
Prop. Delay from REM. ACT. Pin	$V_{REM. ACT.} = 0.4\text{V}$		300			300		ns
Prop. Delay fom O.V. INPUT Pin	$V_{O.V. INPUT} = 2.7\text{V}$		500			500		ns
Current Limit Section								
Input Voltage Range		0		$V_{IN} - 3\text{V}$	0		$V_{IN} - 3\text{V}$	V
Input Bias Current	OFFSET/COMP pin open, $V_{CM} = 0\text{V}$		0.3	1.0		0.3	1.0	μA
Input Offset Voltage	OFFSET/COMP pin open, $V_{CM} = 0\text{V}$, 10k Ω from OFFSET/COMP pin to Gnd, $T_J = 25^\circ\text{C}$	80	100	120	70	100	130	mV
CMRR	$0 \leq V_{CM} \leq 12\text{V}, V_{IN} = 15\text{V}$	60	70		60	70		dB
AVOL	OFFSET/COMP pin open, $V_{CM} = 0\text{V}$	72	80		72	80		dB
Output Saturation	$I_L = 10\text{mA}$		0.2	0.5		0.2	0.5	V
Output Leakage	$V_{IND} = 40\text{V}$.01	1.0		.01	1.0	μA
Small Signal Bandwidth	$A_V = 0\text{dB}, T_J = 25^\circ\text{C}$		5			5		MHz
Propagation Delay	$V_{OVERDRIVE} = 100\text{mV}, T_J = 25^\circ\text{C}$		200			200		ns

Note 5. Input voltage rising on O.V. Input and falling on U.V. Input.

CHARACTERISTIC CURVES

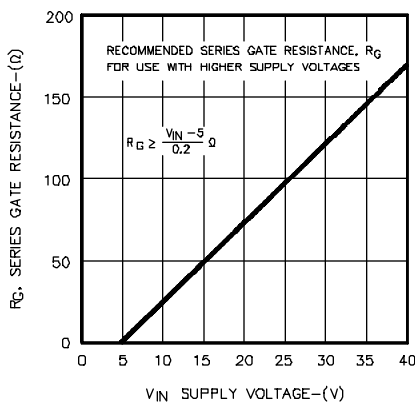

FIGURE 1.
SCR TRIGGER POWER LIMITING

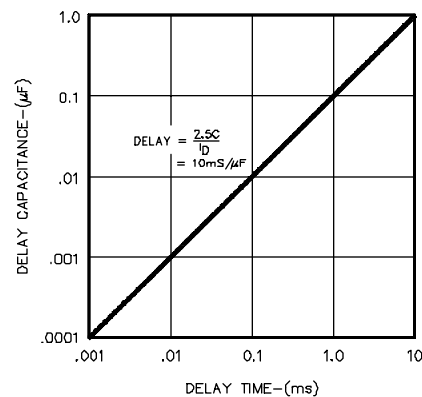

FIGURE 2 .
ACTIVATION DELAY VS. CAPACITOR VALUE

CHARACTERISTIC CURVES (continued)

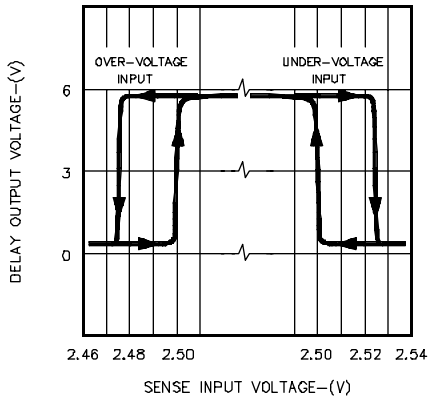

FIGURE 3. COMPARATOR INPUT HYSTERESIS

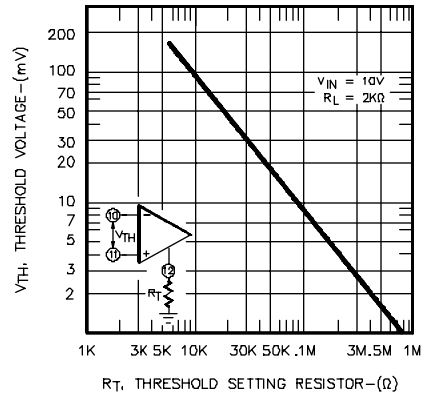

FIGURE 4. CURRENT LIMIT INPUT THRESHOLD

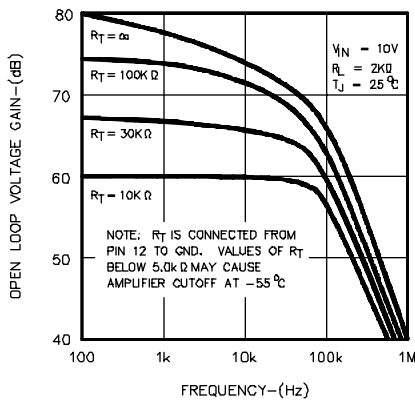

FIGURE 5. CURRENT LIMIT AMPLIFIER GAIN

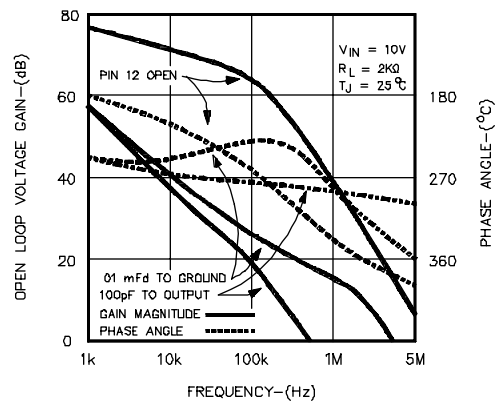

FIGURE 6. CURRENT LIMIT AMPLIFIER FREQUENCY RESPONSE

APPLICATION INFORMATION

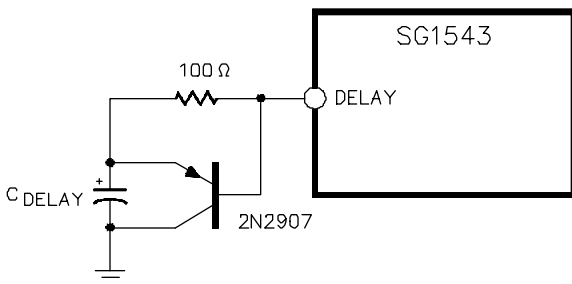

FIGURE 7 - SURGE LIMIT CIRCUIT FOR LARGE DELAY CAPACITORS

The 100 ohm resistor limits the peak discharge current into the SG1543 while the external PNP transistor provides a high peak-current discharge path for the delay capacitor.

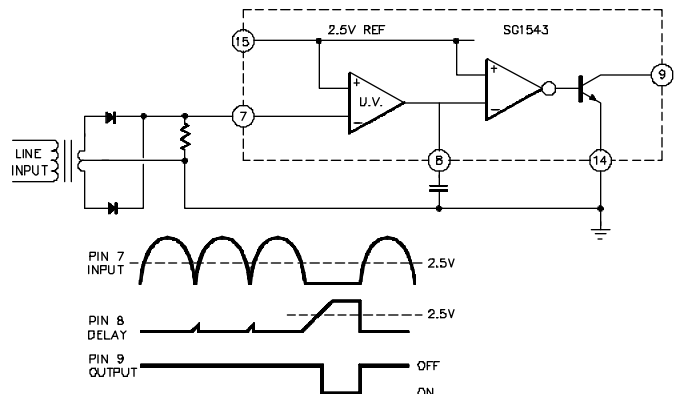

FIGURE 8 - INPUT LINE MONITOR

APPLICATION INFORMATION (continued)

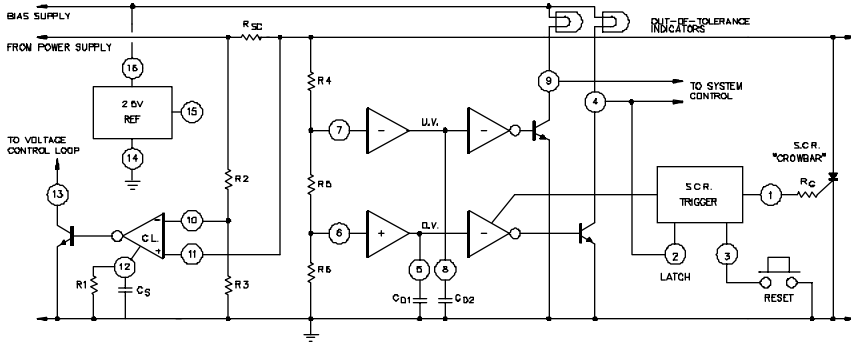

FIGURE 9 - TYPICAL APPLICATION CIRCUIT

The values for the external components are determined as follows:

$$\text{Current limit input threshold, } V_{TH} \approx \frac{1000}{R_1}$$

C_S is determined by the current loop dynamics

$$\text{Peak current to load, } I_p \approx \frac{V_{TH}}{R_{SC}} + \frac{V_o}{R_{SC}} \left(\frac{R_2}{R_2 + R_3} \right)$$

$$\text{Short circuit current, } I_{SC} = \frac{V_{TH}}{R_{SC}}$$

$$\text{Low output voltage limit, } V_o (\text{Low}) = \frac{2.5 (R_4 + R_5 + R_6)}{R_5 + R_6}$$

$$\text{High output voltage limit, } V_o (\text{High}) = \frac{2.5 (R_4 + R_5 + R_6)}{R_6}$$

$$\text{Voltage sensing delay, } t_D = 10,000 C_D$$

$$\text{SCR trigger power limiting resistor, } R_G > \frac{V_{IN} - 5}{0.2}$$

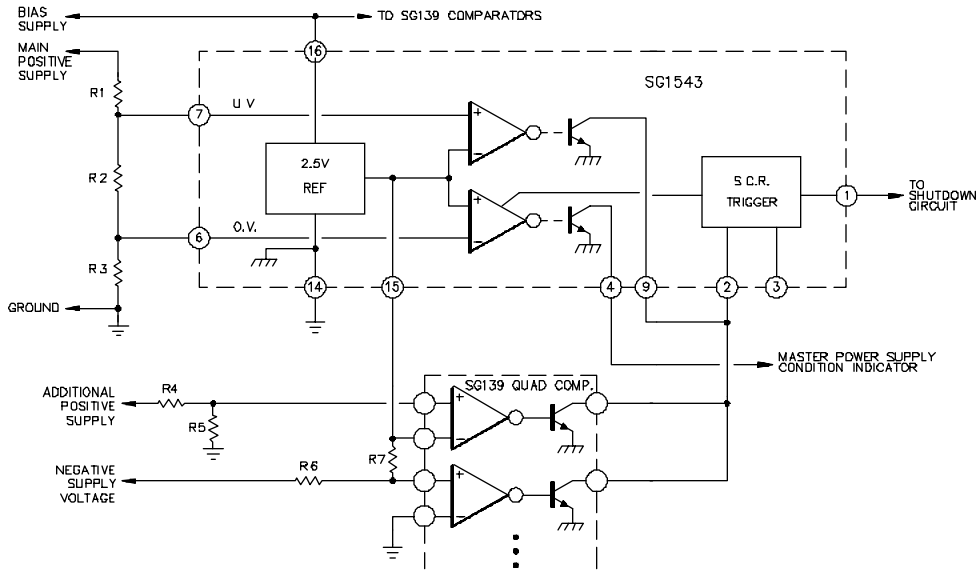

FIGURE 10 - SENSING MULTIPLE SUPPLY VOLTAGES

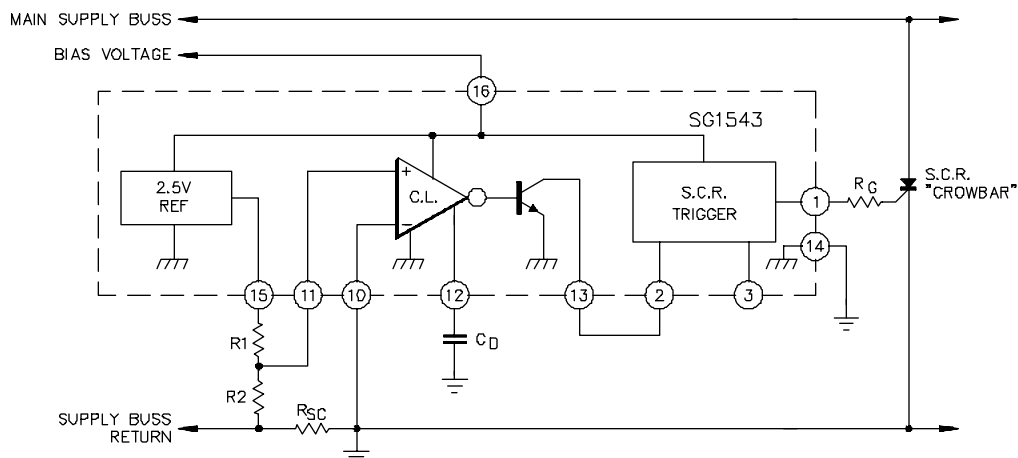

FIGURE 11 - OVERCURRENT SHUTDOWN

SG1543/SG2543/SG3543

CONNECTION DIAGRAMS & ORDERING INFORMATION (See Notes Below)

Package	Part No.	Ambient Temperature Range	Connection Diagram
16-PIN CERAMIC DIP J - PACKAGE 16-PIN PLASTIC DIP N - PACKAGE	SG1543J/883B SG1543J/DESC SG1543J SG2543J SG3543J SG2543N SG3543N	-55°C to 125°C -55°C to 125°C -55°C to 125°C -25°C to 85°C 0°C to 70°C -25°C to 85°C 0°C to 70°C	
16-PIN WIDE BODY PLASTIC S.O.I.C. DW - PACKAGE	SG2543DW SG3543DW	-25°C to 85°C 0°C to 70°C	
20-PIN CERAMIC LEADLESS CHIP CARRIER L - PACKAGE (Note 3)	SG1543L/883B SG1543L	-55°C to 125°C -55°C to 125°C	

Note 1. Contact factory for JAN and DESC product availability.
 2. All packages are viewed from the top.
 3. Consult factory for product availability.