



Dual-Slot PCMCIA/CardBus Power Controller

Features

- Fully Integrated V_{CC} and V_{PP} Switching for Dual Slot PC Card™ Interface
- 3-Lead Serial Interface Compatible With CardBus™ Controllers
- 3.3V Low Voltage Mode
- Meets PC Card Standards
- RESET for System Initialization of PC Cards
- 12V Supply Can Be Disabled Except During 12V Flash Programming
- Short Circuit and Thermal Protection
- 28 Pin and 30 Pin SSOP
- Compatible With 3.3V, 5V and 12V PC Cards
- Low $R_{DS(on)}$ (225-m Ω 5V V_{CC} Switch; 200 m Ω 3.3V V_{CC} Switch)
- Break-Before-Make Switching
- Internal power-On Reset

Application

- Notebook PC
- Electronic Dictionary
- Personal Digital Assistance
- Digital still Camera

Description

The G570 PC Card power-interface switch provides an integrated power-management solution for two PC Cards. All of the discrete power MOSFETs, a logic section, current limiting, and thermal protection for PC Card control are combined on a single integrated circuit (IC). The circuit allows the distribution of 3.3V, 5V, and/or 12V card power by means of the Serial interface. The current-limiting feature eliminates the need for fuses, which reduces component count and improves reliability.

The G570 features a 3.3V low voltage mode that allows for 3.3V switching without the need for 5V supply. This facilitates low power system designs such as sleep mode and pager mode where only 3.3V is available.

The G570 incorporates a reset function, selectable by one of two inputs, to help alleviate system errors. The reset function enables PC card initialization concurrent with host platform initialization, allowing a system reset. Reset is accomplished by grounding the V_{CC} and V_{PP} (flash-memory programming voltage) outputs, which discharges residual card voltage.

End equipment for the G570 includes notebook computers, desktop computers, personal digital assistants (PDAs), digital cameras and bar-code scanners.

Ordering Information

PART NUMBER	TEMP. RANGE	PACKAGE
G570S4	-40°C to +85°C	28 SSOP
G570SA	-40°C to +85°C	30 SSOP

Pin Information

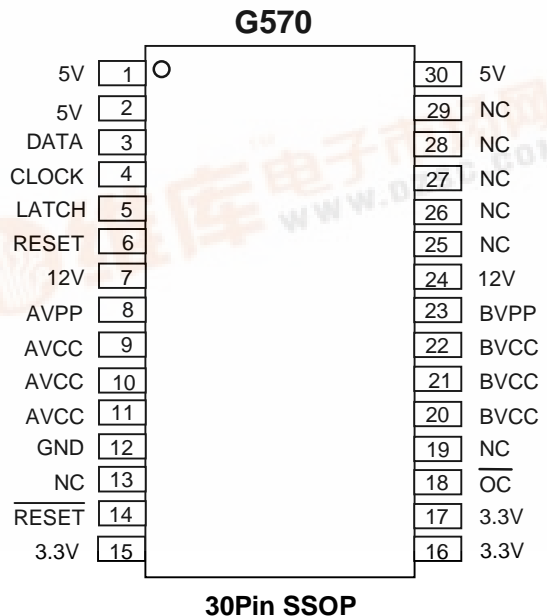
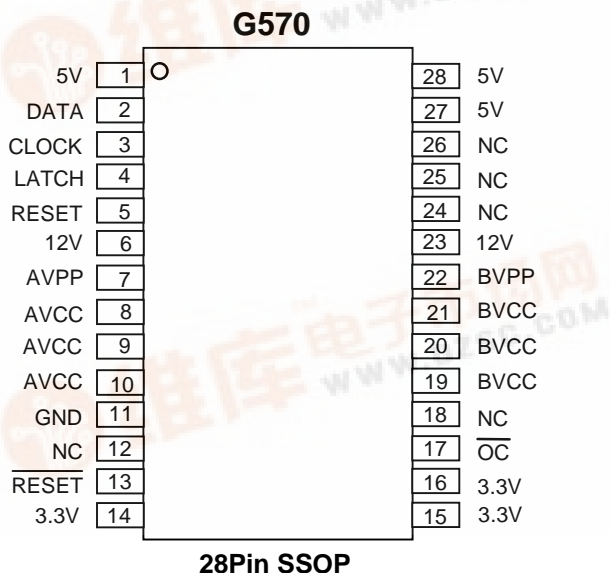

Absolute maximum ratings over operating free-air temperature (unless otherwise noted)*

Input voltage range for card power:
 $V_{I(3.3V)}$-0.3V to 7V
 $V_{I(5V)}$-0.3V to 7V
 $V_{I(12V)}$ -0.3V to 14V
 Logic input voltage.....-0.3V to 7V

Output current (each card):

$I_{O(xVCC)}$internally limited
 $I_{O(xVPP)}$ internally limited
 Operating virtual junction temperature range, T_J
-40°C to 150°C
 Operating free-air temperature range, T_A
-40°C to 85°C
 Storage temperature range, T_{STG}-55°C to 150°C

*Stresses beyond those listed under "absolute maximum ratings" may cause permanent damage to the device. These are stress rating only, and functional operation of the device at these or any other conditions beyond those indicated under "recommended operating conditions" is not implied. Exposure to absolute-maximum-rated conditions for extended periods may affect device reliability.

Recommended Operating Conditions

		Min	Max	Unit
Input voltage range, V_I	$V_{I(5V)}$	0	5.25	V
	$V_{I(3.3V)}$	0	5.25	V
	$V_{I(12V)}$	0	13.5	V
Output current	$I_{O(xVCC)}$ at 25°C		1	A
	$I_{O(xVPP)}$ at 25°C		150	mA
Clock frequency		0	2.5	MHz
Operating virtual junction temperature, T_J		-40	125	°C

Typical PC Card Power-Distribution Application

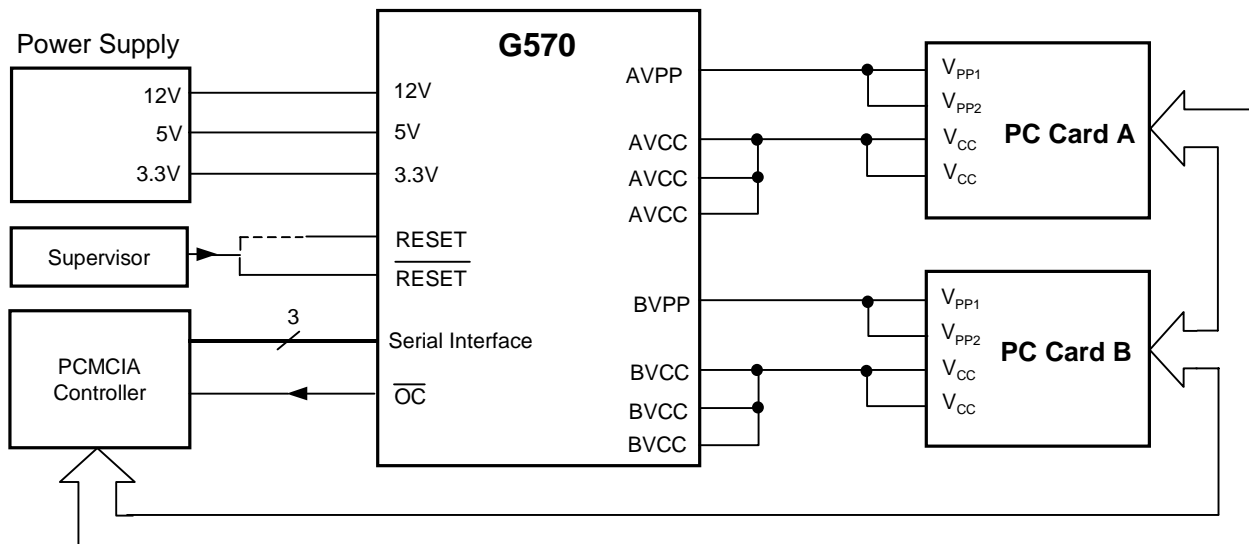

Terminal Functions
28 Pin

TERMINAL		I/O	DESCRIPTION
NAME	NO.		
3.3V	14,15,16	I	3.3V V _{CC} input for card power
5V	1,27,28	I	5V V _{CC} input for card power and/or chip power
12V	6,23	I	12V V _{PP} input for card power
AVCC	8,9,10	O	Switched output that delivers 0V,3.3V,5V or high impedance to card
AVPP	7	O	Switched output that delivers 0V,3.3V,5V,12V or high impedance to card
BVCC	19,20,21	O	Switched output that delivers 0V, 3.3V, 5V or high impedance
BVPP	22	O	Switch output that delivers 0V, 3.3V, 5V, 12V or high impedance
CLOCK	3	I	Logic-level clock for serial data word
DATA	2	I	Logic-level serial data word
GND	11		Ground
LATCH	4	I	Logic level latch for serial data word
NC	12,18,24,25,26		No internal connection
$\overline{\text{OC}}$	17	O	Logic-level overcurrent. $\overline{\text{OC}}$ reports output that goes low when an overcurrent condition exists
RESET	5	I	Logic-level RESET input active high. Do not connect if terminal 13 is used.
$\overline{\text{RESET}}$	13	I	Logic-level $\overline{\text{RESET}}$ input active low. Do not connect if terminal 5 is used.

30 Pin

TERMINAL		I/O	DESCRIPTION
NAME	NO.		
3.3V	15,16,17	I	3.3V V _{CC} input for card power
5V	1,2,30	I	5V V _{CC} input for card power and/or chip power
12V	7,24	I	12V V _{PP} input for card power
AVCC	9,10,11	O	Switched output that delivers 0V,3.3V,5V or high impedance to card
AVPP	8	O	Switched output that delivers 0V,3.3V,5V,12V or high impedance to card
BVCC	20,21,22	O	Switched output that delivers 0V, 3.3V, 5V or high impedance
BVPP	23	O	Switch output that delivers 0V, 3.3V, 5V, 12V or high impedance
CLOCK	4	I	Logic level clock for serial data word
DATA	3	I	Logic level serial data word
GND	12		Ground
LATCH	5	I	Logic level latch for serial data word
NC	13,19,25,26, 27,28,29		No internal connection
$\overline{\text{OC}}$	18	O	Logic-level overcurrent. $\overline{\text{OC}}$ reports output that goes low when an overcurrent condition exists
RESET	6	I	Logic-level RESET input active high. Do not connect if terminal 14 is used.
$\overline{\text{RESET}}$	14	I	Logic-level $\overline{\text{RESET}}$ input active low. Do not connect if terminal 6 is used.



Electrical Characteristics ($T_A = 25^\circ\text{C}$, $V_{I(5V)} = 5\text{V}$; unless otherwise noted)

DC Characteristics

PARAMETER		TEST CONDITIONS	MIN	TYP	MAX	UNIT
Switch resistance*	5V to x VCC			170	225	mΩ
	3.3V to x VCC	$V_{I(5V)} = 5\text{V}$, $V_{I(3.3V)} = 3.3\text{V}$		140	200	
	3.3V to x VCC	$V_{I(5V)} = 0\text{V}$, $V_{I(3.3V)} = 3.3\text{V}$		150	200	
	5V to x VPP				6	Ω
	3.3V to x VPP				6	
	12V to x VPP				6	
$V_{O(xVPP)}$ Clamp low voltage		I_{PP} at 10mA			0.8	V
$V_{O(xVCC)}$ Clamp low voltage		I_{CC} at 10mA			0.8	V
I_{IKG} Leakage current	I_{PP} high impedance State	$T_A = 25^\circ\text{C}$		1	10	μA
	I_{CC} high-impedance State	$T_A = 25^\circ\text{C}$		1	10	
I_I Input current	$V_{I(5V)} = 5\text{V}$	$V_{O(AVCC)} = V_{O(BVCC)} = 5\text{V}$ $V_{O(AVPP)} = V_{O(BVPP)} = 12\text{V}$		115	150	μA
	$V_{I(5V)} = 0\text{V}$ $V_{I(3.3V)} = 3.3\text{V}$	$V_{O(AVCC)} = V_{O(BVCC)} = 3.3\text{V}$ $V_{O(AVPP)} = V_{O(BVPP)} = 0\text{V}$		131	150	
	Shutdown mode	$V_{O(BVCC)} = V_{O(AVCC)}$ $= V_{O(AVPP)} = V_{O(BVPP)} = \text{Hi-Z}$		2		
I_{OS} Short-circuit Output current Limit	$I_{O(xVCC)}$	Output powered up into a short to GND	0.8		2.2	A
	$I_{O(xVPP)}$		120		400	mA

*Pulse-testing techniques are used to maintain junction temperature close to ambient temperatures; thermal effects must be taken into account separately.

Logic Section

PARAMETER	TEST CONDITION	MIN	MAX	UNIT
Logic input current			1	μA
Logic input high level		2		V
Logic input low level			0.8	V
Logic output high level	$V_{I(5V)} = 5\text{V}$, $I_O = 1\text{mA}$	$V_{I(5V)} - 0.4$		V
	$V_{I(5V)} = 0\text{V}$, $I_O = 1\text{mA}$	$V_{I(3.3V)} - 0.4$		
	$V_{I(3.3V)} = 3.3\text{V}$			
Logic output low level	$I_O = 1\text{mA}$		0.4	V

Switching Characteristics * , **

PARAMETER	TEST CONDITION	MIN	TYP	MAX	UNIT
t_r Output rise time	$V_{O(xVCC)}$		2		ms
	$V_{O(xVPP)}$		10		
t_f Output fall time	$V_{O(xVCC)}$		16		
	$V_{O(xVPP)}$		45		
t_{pd} Propagation delay (see Figure 1)	LATCH ↑ to $V_{O(xVPP)}$	t_{on}	7		ms
		t_{off}	30		ms
	LATCH ↑ to $V_{O(xVCC)}$ (3.3V), $V_{I(5V)} = 5\text{V}$	t_{on}	5		ms
		t_{off}	16		ms
	LATCH ↑ to $V_{O(xVCC)}$ (5V)	t_{on}	3.2		ms
		t_{off}	25		ms
	LATCH ↑ to $V_{O(xVCC)}$ (3.3V), $V_{I(5V)} = 0\text{V}$	t_{on}	6		ms
		t_{off}	21		ms

* Refer to Parameter Measurement Information

**Switching Characteristics are with $C_L = 147\mu\text{F}$

Parameter Measurement Information

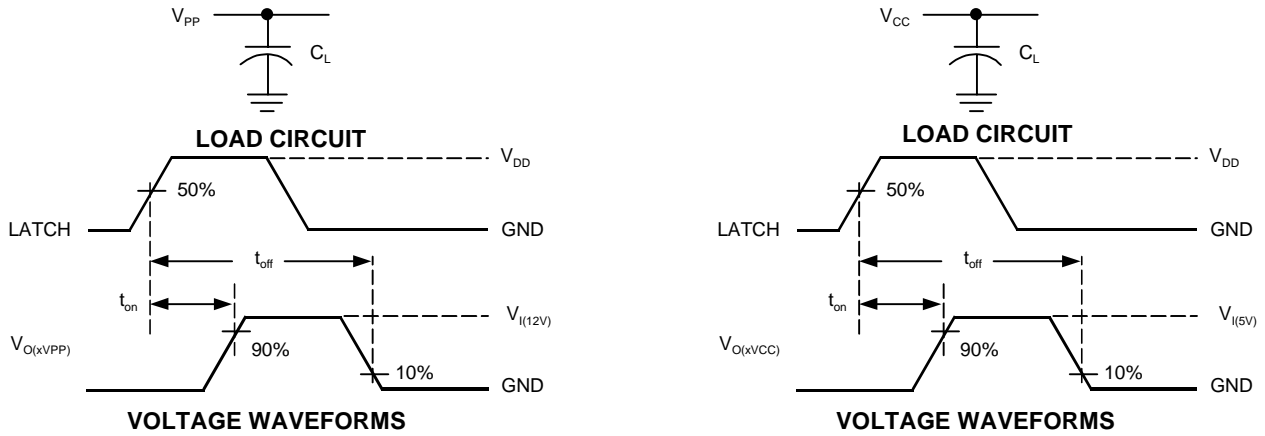
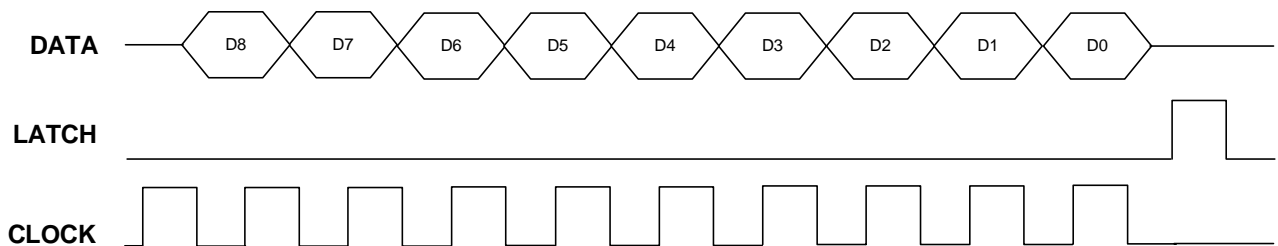

Figure 1. Test Circuits and Voltage Waveforms

Table of Timing Diagrams



Note: Data is clocked in on the positive leading edge of the clock. The latch should occur before the next positive leading edge of the clock. For definition of D0 to D8, see the control logic table.

Figure 2. Serial-Interface Timing



Switching Characteristics

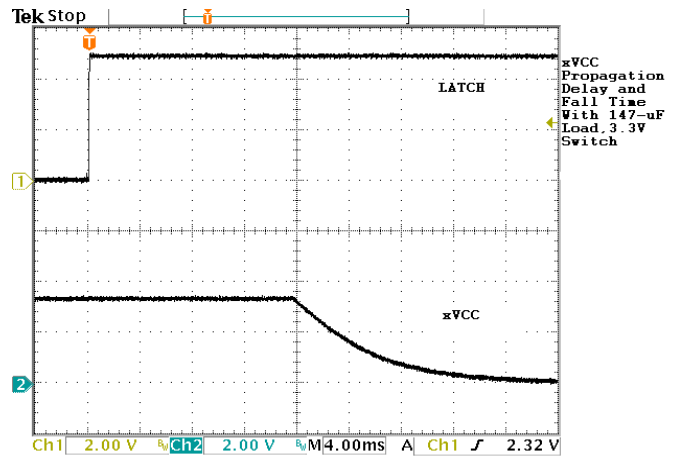
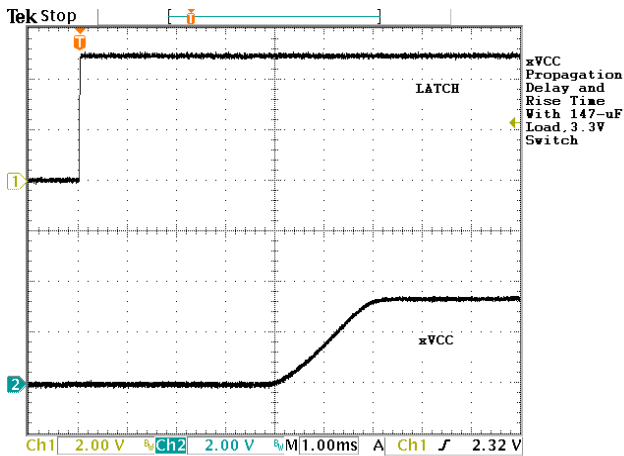
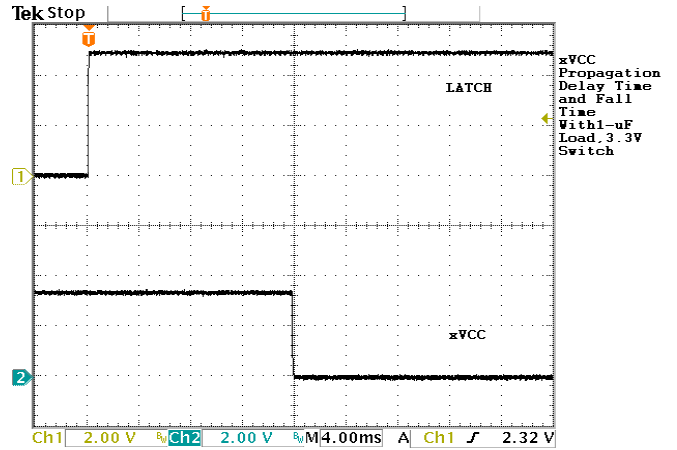
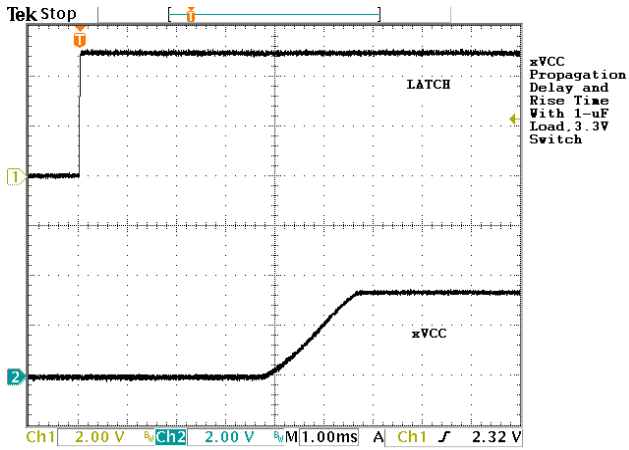

Switching Characteristics

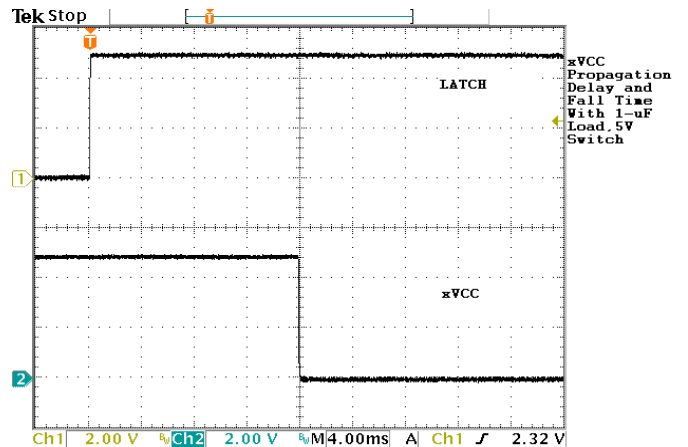
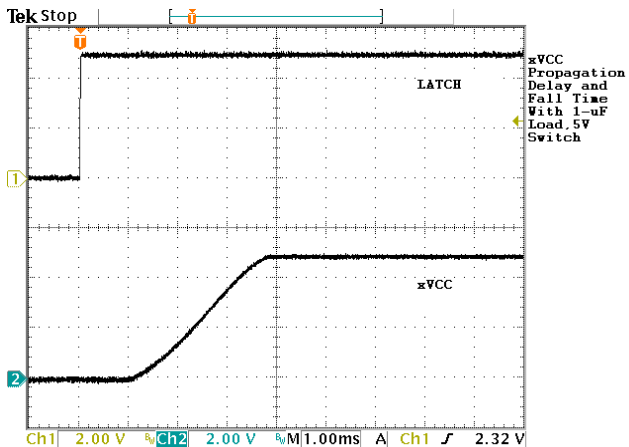

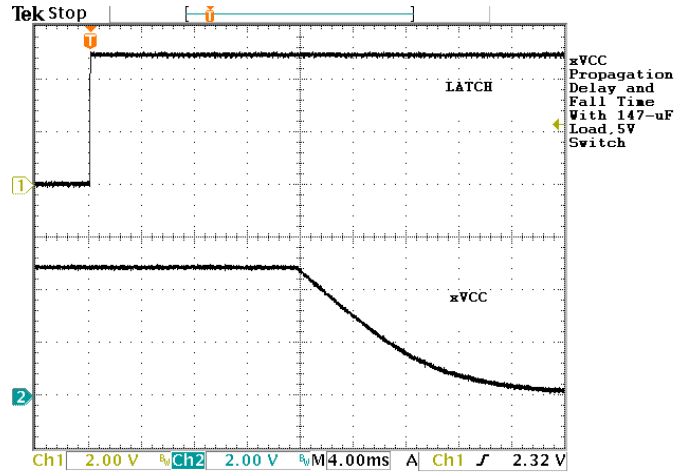
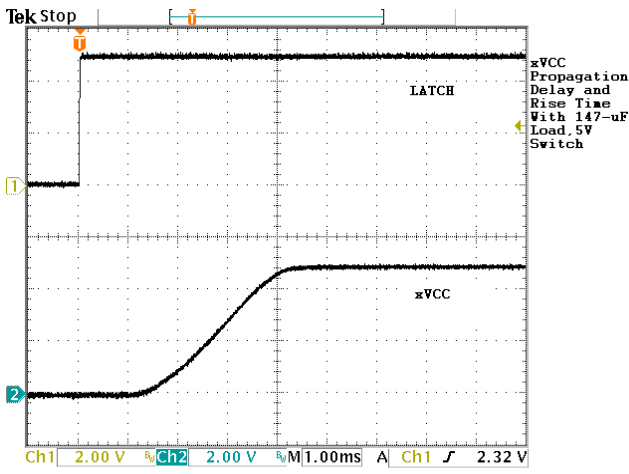

Switching Characteristics

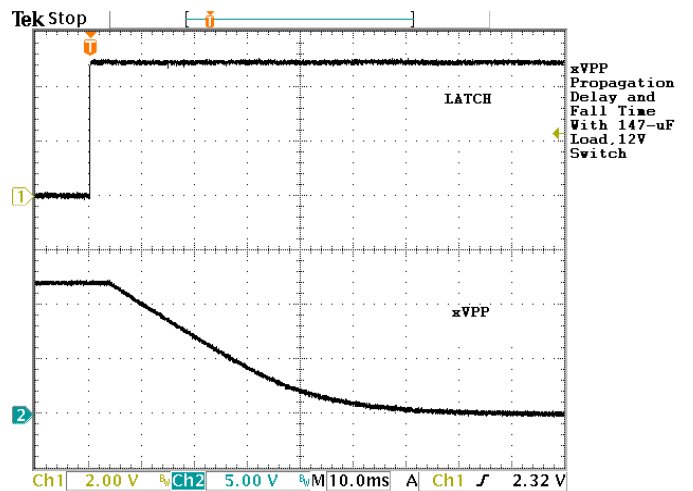
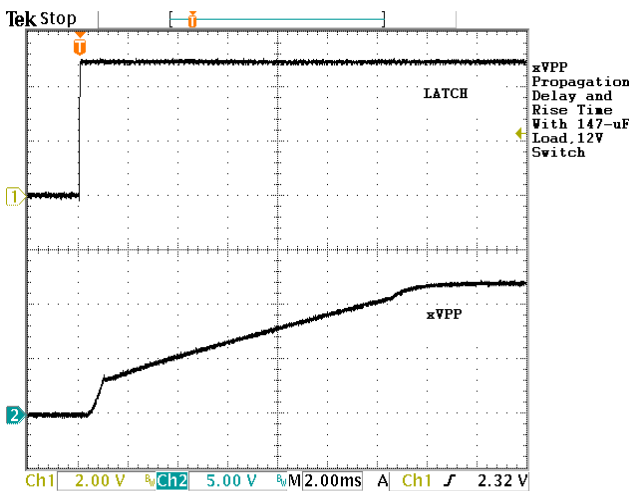
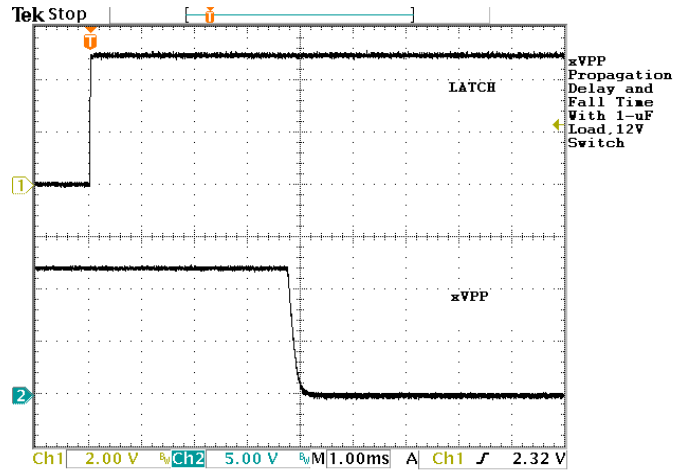
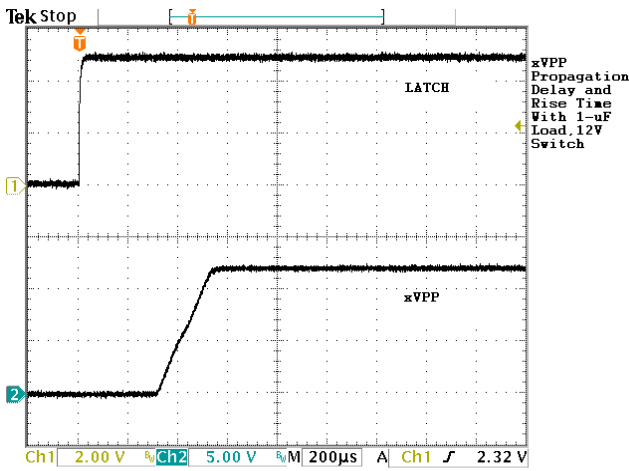



Application Information

Overview

PC Cards were initially introduced as a means to add EEPROM (flash memory) to portable computers with limited on-board memory. The idea of add-in cards quickly took hold; modems, wireless LANs, Global Positioning Satellite (GPS), multimedia, and hard-disk versions were soon available. As the number of PC Card applications grew, the engineering community quickly recognized the need for a standard to ensure compatibility across platforms. To this end, the PCMCIA was established, comprised of members from leading computer, software, PC Card, and semiconductor manufactures. One key goal was to realize the “plug-and play” concept. Cards and hosts from different vendors should be compatible—able to communicate with one another transparently.

PC Card Power Specification

System compatibility also means power compatibility. The most current set of specifications (PC Card Standard) set forth by the PCMCIA committee states that power is to be transferred between the host and the card through eight of the 68 terminals of the PC Card connector. This power interface consists of two V_{CC} , two V_{PP} , and four ground terminals. Multiple V_{CC} and ground terminals minimize connector-terminal and line resistance. The two V_{PP} terminals were originally specified as separate signals but are commonly tied together in the host to form a single node to minimize voltage losses. Card primary power is supplied through the V_{CC} terminals; flash-memory programming and erase voltage is supplied through the V_{PP} terminals.

Overcurrent and Over-Temperature Protection

PC Cards are inherently subject to damage that can result from mishandling. Host systems require protection against short-circuited cards that could lead to power supply or PCB-trace damage. Even systems robust enough to withstand a short circuit would still undergo rapid battery discharge into the damaged PC Card, resulting in the rather sudden and unacceptable loss of system power. Most hosts include fuses for protection. However, the reliability of fused systems is poor, as blown fuses require troubleshooting and repair, usually by the manufacturer.

The G570 takes a two-pronged approach to overcurrent protection. First, instead of fuses, sense FETs monitor each of the power outputs. Excessive current generates an error signal that linearly limits the output current, preventing host damage or failure. Sense FETs, unlike sense resistors or polyfuses, have an added advantage in that they do not add to the series

resistance of the switch and thus produce no additional voltage losses. Second, when an overcurrent condition is detected, the G570 asserts a signal at \overline{OC} that can be monitored by the microprocessor to initiate diagnostics and/or send the user a warning message. In the event that an overcurrent condition persists, causing the IC to exceed its maximum junction temperature, thermal-protection circuitry activates, shutting down all power outputs until the device cools to within a safe operating region.

12V Supply Not Required

Most PC Card switches use the externally supplied 12V V_{PP} power for switch-gate drive and other chip functions, which requires that power be present at all times. The G570 offers considerable power savings by using an internal charge pump to generate the required higher voltages from 5V or 3.3V input; therefore, the external 12V supply can be disabled except when needed for flash-memory functions, thereby extending battery lifetime. Do not ground the 12V input if the 12V input is not used. Additional power savings are realized by the G570 during a software shutdown in which quiescent current drops to a typical of 2 μ A.

3.3V Low Voltage Mode

The G570 operates in 3.3V low voltage mode when 3.3V is the only available input voltage ($V_{I(5V)}=0$). This allows host and PC Cards to be operated in low power 3.3V only modes such as sleep modes or pager modes. Note that in this operation mode, the G570 derives its bias current from the 3.3V input pin and only 3.3V can be delivered to the Card. The 3.3V switch resistance increases, but the added switch resistance should not be critical, because only a small amount of current is delivered in this mode.

Voltage Transitioning Requirement

PC Cards, like portables, are migrating from 5V to 3.3V to minimize power consumption, optimize board space, and increase logic speeds. The G570 is designed to meet all combinations of power delivery as currently defined in the PCMCIA standard. The latest protocol accommodates mixed 3.3V/5V systems by first powering the card with 5V, then polling it to determine its 3.3V compatibility. The PCMCIA specification requires that the capacitors on 3.3V compatible cards be discharged to below 0.8 V before applying 3.3V power. This ensures that sensitive 3.3V circuitry is not subjected to any residual 5V charge and functions as a power reset. The G570 offer a selectable V_{CC} and V_{PP} ground state, in accordance with PCMCIA 3.3V/5V switching specifications, to fully discharge the card capacitors while switching between V_{CC} voltage.

**Output Ground Switches**

Several PCMCIA power distribution switches on the market do not have an active grounding FET switch. These devices do not meet the PC Card specification requiring a discharge of V_{CC} within 100ms. PC Card resistance can not be relied on to provide a discharge path for voltages stored on PC Card capacitance because of possible high impedance isolation by power management schemes. A method commonly shown to alleviate this problem is to add to the switch output an external $100k\Omega$ resistor in parallel with the PC Card. Considering that this is the only discharge path to ground, a timing analysis show that the RC time constant delays the required discharge time to more than 2 seconds. The only way to ensure timing compatibility with PC Card standards is to use a power-distribution switch that has an internal ground switch, like that of the G570, or add an external ground FET to each of the output lines with the control logic necessary to select it.

In summary, the G570 is a complete single-chip dual-slot PC Card power interface. It meets all currently defined PCMCIA specifications for power delivery in 5V, 3.3V, and mixed systems, and offers a serial control interface. The G570 offers functionality, power savings, overcurrent and thermal protection, and fault reporting in one 30 pin SSOP surface-mount package for maximum value added to new portable designs.

Power Supply Considerations

The G570 has multiple pins for each of its 3.3V, 5V, and 12V power inputs and for switched V_{CC} outputs. Any individual pin can conduct the rated input or output current. Unless all pins are connected in parallel, the series resistance is significantly higher than that specified, resulting in increased voltage drops and lost power. Both 12V inputs must be connected for proper V_{PP} switching; it is recommended that all input and output power pins be paralleled for optimum operation.

Although the G570 is fairly immune to power input fluctuations and noise, it is generally considered good design practice to bypass power supplies typically with a $1\mu F$ electrolytic or tantalum capacitor paralleled by a $0.047\mu F$ to $0.1\mu F$ ceramic capacitor. It is strongly recommended that the switched V_{CC} and V_{PP} outputs be bypassed with a $0.1\mu F$ or larger capacitor; doing so improves the immunity of the G570 to electrostatic discharge (ESD). Care should be taken to minimize the inductance of PCB traces between the G570 and the load. High switching currents can produce large negative-voltage transients, which forward biases substrate diodes, resulting in unpredictable performance. Similarly, no pin should be taken below $-0.3V$.

RESET or \overline{RESET} Inputs

To ensure that cards are in a known state after power brownouts or system initialization, the PC Cards should be reset at the same time as the host by applying a low impedance to the V_{CC} and V_{PP} terminals. A low impedance output state allows discharging of residual voltage remaining on PC Card filter capacitance, permitting the system (host and PC Cards) to be powered up concurrently. The RESET or \overline{RESET} input closes internal switches S1, S4, S7, and S10 with all other switches left open (see G570 control logic table). The G570 remains in the low impedance output state until the signal is deasserted and further data is clocked in and latched. RESET or \overline{RESET} is provided for direct compatibility with systems that use either an active-low or active-high reset voltage supervisor. The unused pin is internally pulled up or down and should be left unconnected.

Overcurrent and Thermal Protection

The G570 uses sense FETs to check for overcurrent conditions in each of the V_{CC} and V_{PP} outputs. Unlike sense resistors or polyfuses, these FETs do not add to the series resistance of the switch; therefore, voltage and power losses are reduced. Overcurrent sensing is applied to each output separately. When an overcurrent condition is detected, only the power output affected is limited; all other power outputs continue to function normally. The OC indicator, normally a logic high, is a logic low when any overcurrent condition is detected, providing for initiation of system diagnostics and/or sending a warning message to the user.

During power up, the G570 controls the rise time of the V_{CC} and V_{PP} outputs and limits the current into a faulty card or connector. If a short circuit is applied after power is established (e.g., hot insertion of a bad card), current is initially limited only by the impedance between the short and the power supply. In extreme cases, as much as 10A to 15A may flow into the short before the current limiting of the G570 engages. If the V_{CC} or V_{PP} outputs are driven below ground, the G570 may latch nondestructively in an off state. Cycling power will reestablish normal operation.

Overcurrent limiting for the V_{CC} outputs is designed to activate, if powered up, into a short in the range of 0.8A to 2.2A. The V_{PP} outputs limit from 120mA to 400mA. The protection circuitry acts by linearly limiting the current passing through the switch rather than initiating a full shutdown of the supply. Shutdown occurs only during thermal limiting.

Thermal limiting prevents destruction of the IC from overheating if the package power-dissipation ratings are exceeded. Thermal limiting disables all power outputs (both A and B slots) until the device has cooled.

Logic Input and Outputs

The serial interface consists of DATA, CLOCK, and LATCH leads. The data is clocked in on the positive leading edge of the clock (see Figure 2). The 9-bit (D0 through D8) serial data word is loaded during the positive edge of the latch signal. The latch signal should occur before the next positive leading edge of the block.

The shutdown bit of the data word places all V_{CC} and V_{PP} outputs in a high-impedance state and reduces chip quiescent current to $2\mu A$ to conserve battery power.

The G570 serial interface is designed to be compatible with serial-interface PCMCIA controllers and current PCMCIA and Japan Electronic Industry Development Association (JEIDA) standards.

An overcurrent output (\overline{OC}) is provided to indicate an overcurrent condition in any of the V_{CC} or V_{PP} outputs as previously discussed.

An overcurrent output (\overline{OC}) is provided to indicate an overcurrent condition in any of the V_{CC} or V_{PP} outputs as previously discussed.

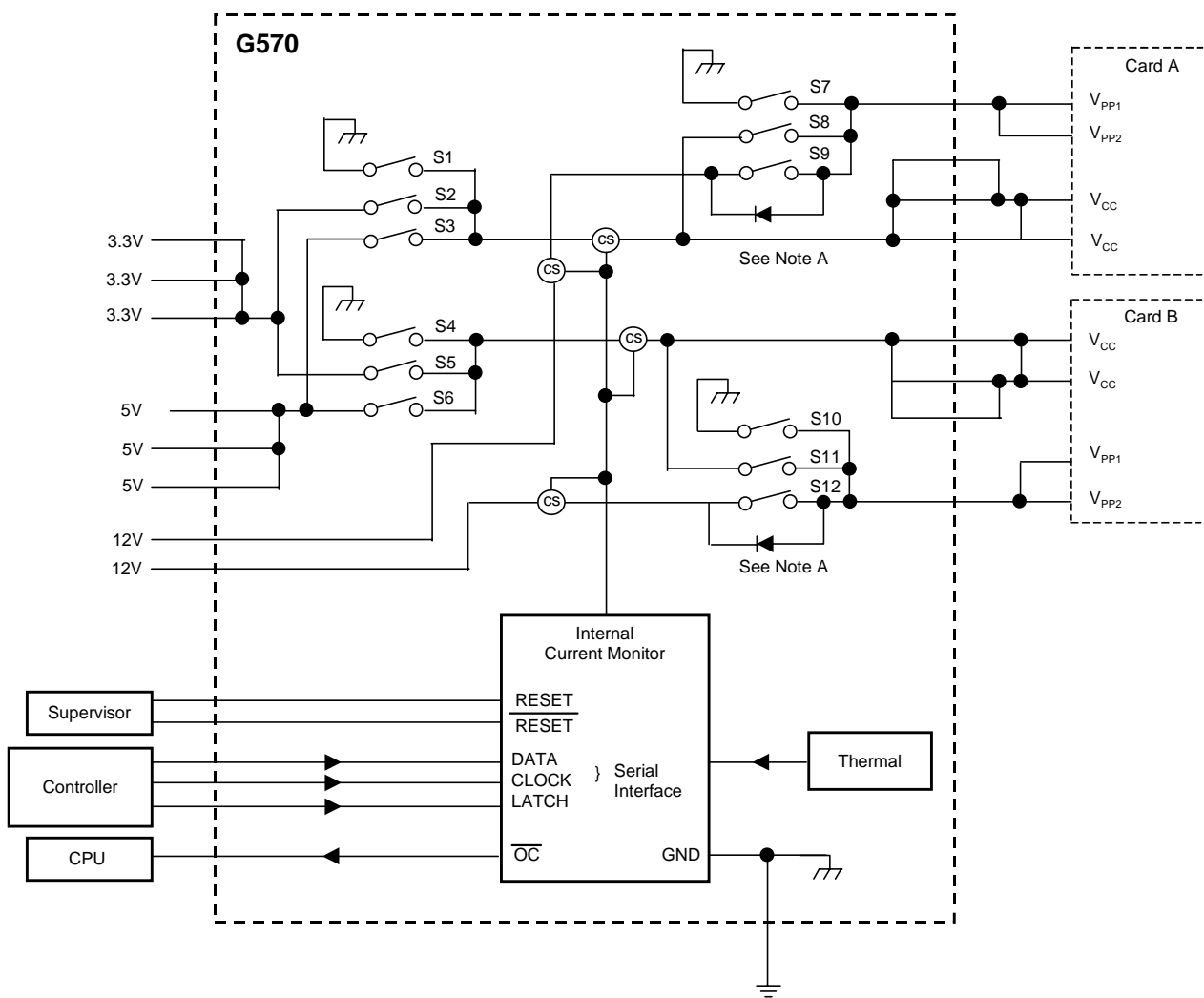

NOTE: MOSFET switches S9 and S12 have a back-gate diode from the source to the drain. Unused switch inputs should never be grounded.

Figure 3 Internal Switching Matrix

G570 control logic
AVPP

CONTROL SIGNALS			INTERNAL SWITCH SETTING			OUTPUT
D8 $\overline{\text{SHDN}}$	D0 A_VPP_PGM	D1 A_VPP_VCC	S7	S8	S9	VAVPP
1	0	0	CLOSED	OPEN	OPEN	0V
1	0	1	OPEN	CLOSED	OPEN	VCC*
1	1	0	OPEN	OPEN	CLOSED	VPP(12V)
1	1	1	OPEN	OPEN	OPEN	Hi-Z
0	x	x	OPEN	OPEN	OPEN	Hi-Z

BVPP

CONTROL SIGNALS			INTERNAL SWITCH SETTING			OUTPUT
D8 $\overline{\text{SHDN}}$	D4 B_VPP_PGM	D5 B_VPP_VCC	S10	S11	S12	VBVPP
1	0	0	CLOSED	OPEN	OPEN	0V
1	0	1	OPEN	CLOSED	OPEN	VCC**
1	1	0	OPEN	OPEN	CLOSED	VPP(12V)
1	1	1	OPEN	OPEN	OPEN	Hi-Z
0	x	x	OPEN	OPEN	OPEN	Hi-Z

AVCC

CONTROL SIGNALS			INTERNAL SWITCH SETTING			OUTPUT
D8 $\overline{\text{SHDN}}$	D3 A_VCC3	D2 A_VCC5	S1	S2	S3	VAVCC
1	0	0	CLOSED	OPEN	OPEN	0V
1	0	1	OPEN	CLOSED	OPEN	3.3V
1	1	0	OPEN	OPEN	CLOSED	5V
1	1	1	CLOSED	OPEN	OPEN	0V
0	x	x	OPEN	OPEN	OPEN	Hi-Z

BVCC

CONTROL SIGNALS			INTERNAL SWITCH SETTING			OUTPUT
D8 $\overline{\text{SHDN}}$	D6 B_VCC3	D7 B_VCC5	S4	S5	S6	VBVCC
1	0	0	CLOSED	OPEN	OPEN	0V
1	0	1	OPEN	CLOSED	OPEN	3.3V
1	1	0	OPEN	OPEN	CLOSED	5V
1	1	1	CLOSED	OPEN	OPEN	0V
0	x	x	OPEN	OPEN	OPEN	Hi-Z

*Output depends on AVCC

**Output depends on BVCC

ESD Protection

All G570 inputs and outputs incorporate ESD-protection circuitry designed to withstand a 2kV human-body-model discharge as defined in MIL-STD-883C, Method 3015. The V_{CC} and V_{PP} out-

puts can be exposed to potentially higher discharges from the external environment through the PC Card connector. Bypassing the outputs with $0.1\mu F$ capacitors protects the devices from discharges up to 10 kV.

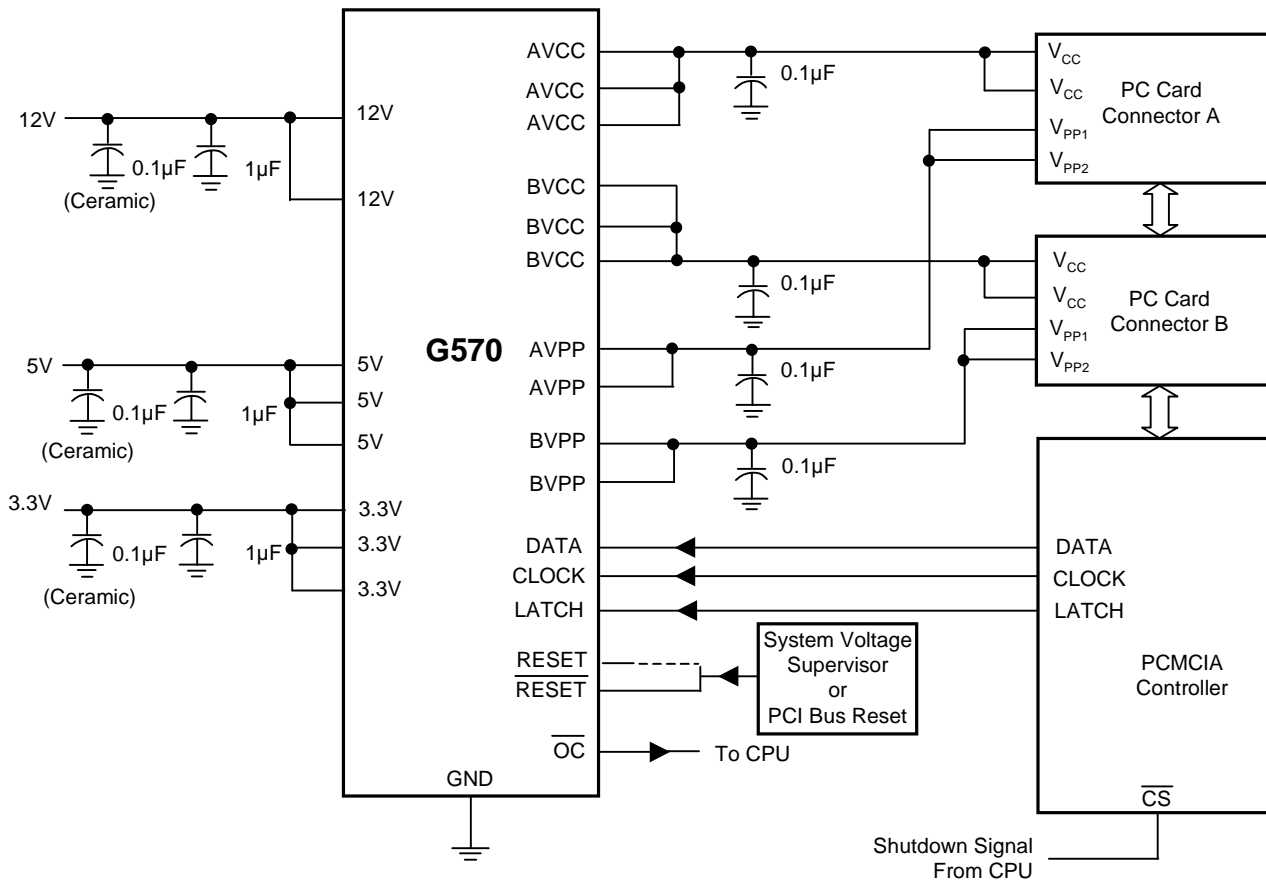
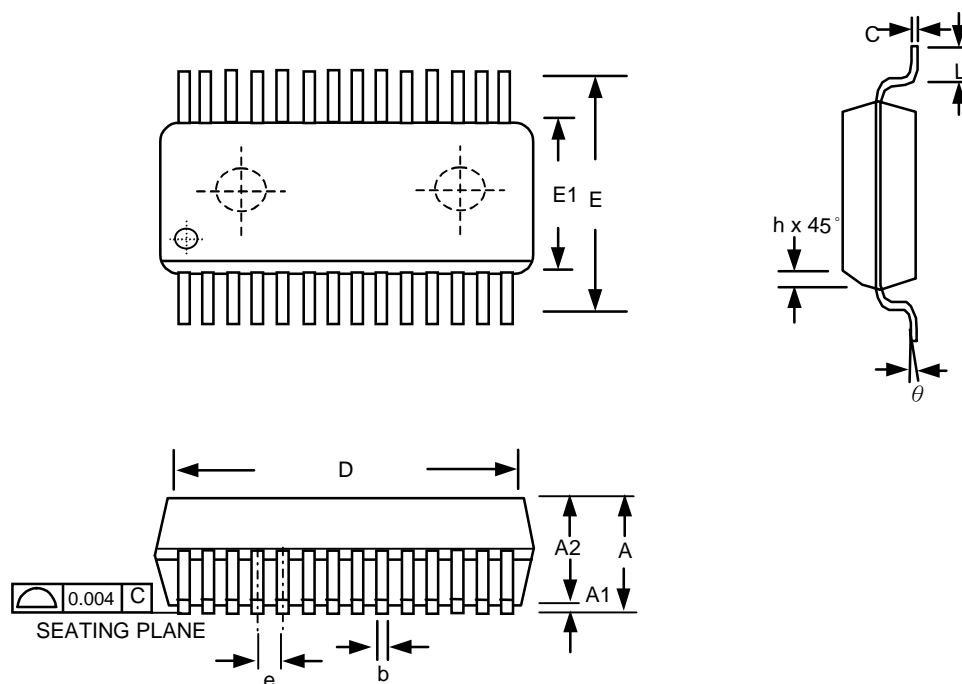

Figure 4. Detailed Interconnections and Capacitor Recommendations

G570 28Pin Package



SYMBOL	DIMENSION IN MM			DIMENSION IN INCH		
	MIN.	NOM.	MAX.	MIN.	NOM.	MAX.
A			2.0			0.079
A1	0.05			0.002		
A2	1.65	1.75	1.85	0.065	0.069	0.073
b	0.22	0.30	0.33	0.009	0.012	0.013
c	0.09	0.15	0.21	0.004	0.006	0.008
e	0.65 BASIC			0.026 BASIC		
D	9.90	10.20	10.50	0.390	0.402	0.413
E	7.40	7.80	8.20	0.291	0.307	0.323
E1	5.00	5.30	5.60	0.197	0.209	0.220
L	0.55	0.75	0.95	0.022	0.030	0.038
θ	0	4	8	0	4	8
JEDEC	MO-150 (AH)					



G570 30Pin Package

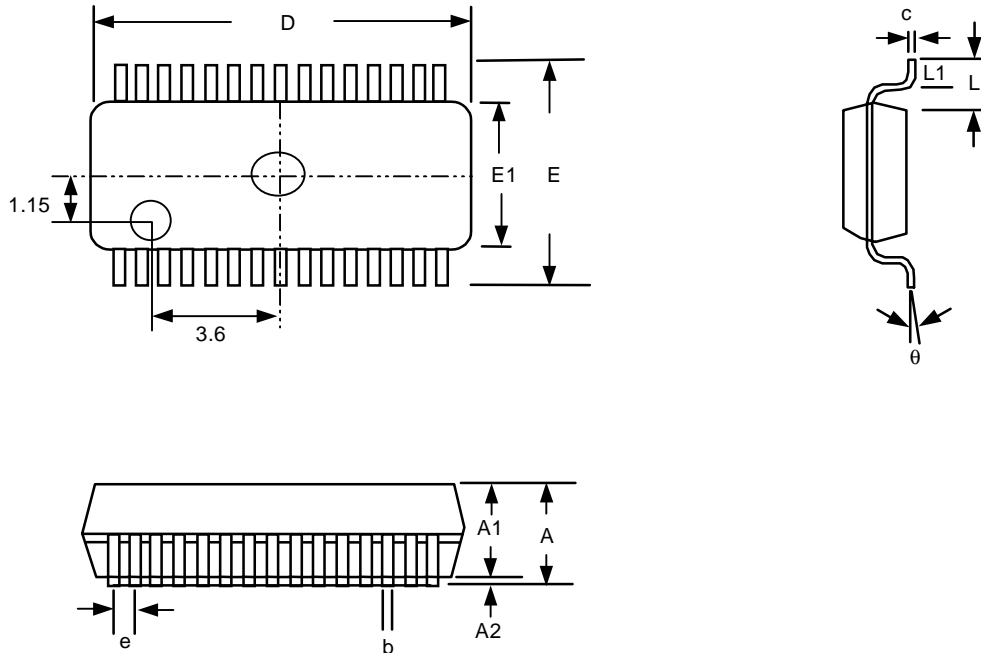

Note:

1. Dimensional tolerance $\pm 0.10\text{mm}$
2. Plating thickness $5\sim 15\mu\text{m}$
3. Dimensions "D" does not include burrs, however dimension including protrusions or gate burrs Shall be MAX. 0.20mm
4. Dimension "E1" does not include inter-lead flash or protrusion. Inter-lead flash or protrusion shall not exceed 0.25 per side.

SYMBOL	DIMENSION IN MM			DIMENSION IN INCH		
	MIN.	NOM.	MAX.	MIN.	NOM.	MAX.
A	1.80	1.90	2.00	0.071	0.075	0.079
A1	0.05	0.10	0.15	0.002	0.004	.006
A2	1.75	1.80	1.85	0.069	0.071	0.073
b	0.25	0.30	0.35	0.010	0.012	0.014
C	0.10	0.15	0.20	0.004	0.006	0.008
D	10.10	10.15	10.20	0.398	0.400	.402
E	7.50	-----	7.90	0.295	-----	0.311
E1	5.20	5.25	5.30	0.205	0.207	0.209
L1	0.53	0.68	0.83	0.021	0.027	0.033
L	1.10	1.20	1.30	0.043	0.047	0.051
e	0.65 BSC			0.026BSC		
θ	1°	4°	7°	1°	4°	7°