



Digital Temperature Sensor and Thermal Watchdog with Two-Wire Interface

Features

- SMBus interface
- Programmable Trip Point (T_{OS}) and Hysteresis (T_{HYST})
- Separate open-drain output pin operates as interrupt or comparator at output
- Register readback capability
- Power up defaults permit stand-alone operation as thermostat
- Shutdown mode to minimize power consumption
- Up to 8 G751s can be connected to a single bus

Key Specifications

- Supply Voltage 3.0V to 5.5V
- Supply Current

operating	280 μ A (typ)
	1mA (max)
shutdown	2 μ A(typ)
- Temperature Accuracy

-25 $^{\circ}$ C to 100 $^{\circ}$ C	$\pm 2^{\circ}$ C (max)
-55 $^{\circ}$ C to 125 $^{\circ}$ C	$\pm 3^{\circ}$ C (max)

Applications

- System Thermal Management
- Personal Computers
- Office Electronics
- Electronic Test Equipment

General Description

The G751 is a temperature sensor, Delta-Sigma analog-to-digital converter, and digital over-temperature detector with SMBus interface. The host can query the G751 at any time to read temperature. The open-drain Over temperature Shutdown (O.S.) output becomes active when the temperature exceeds a programmable limit. This pin can operate in either "Comparator" or "Interrupt" mode.

The host can program both the temperature alarm threshold (T_{OS}) and the temperature at which the alarm condition goes away (T_{HYST}). In addition, the host can read back the contents of the G751's T_{OS} and T_{HYST} registers. The sensor powers up in Comparator mode with default thresholds of 50 $^{\circ}$ C T_{OS} 45 $^{\circ}$ C T_{HYST} . for G751-1 and 80 $^{\circ}$ C T_{OS} , 75 $^{\circ}$ C T_{HYST} for G751-2.

Ordering Information

PART	T_{OS} T_{HYST}	Transport Media	PACKAGE
G751-1	50 $^{\circ}$ C/45 $^{\circ}$ C	2500 Units on Tape and Reel	8 SOP
G751-2	80 $^{\circ}$ C /75 $^{\circ}$ C	2500 Units on Tape and Reel	8 SOP

Pin Configuration

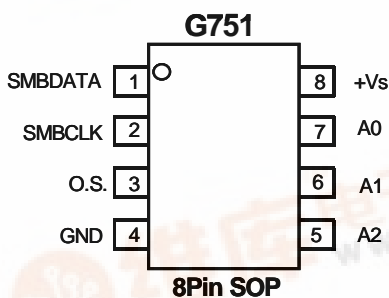

Typical Application

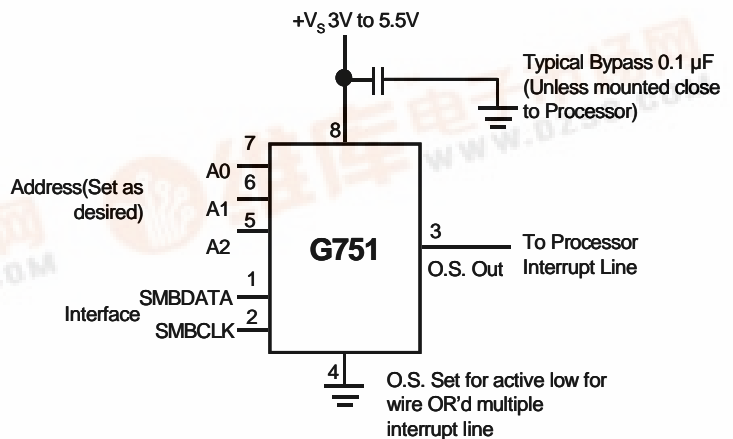

Absolute Maximum Ratings.

Supply Voltage.....	-0.3V to 6.5V
Voltage at any Pin.....	-0.3V to +Vs +0.3V
Input Current at any Pin.....	5mA
Package Input Current.....	20mA
O.S. Output Sink Current.....	10mA
O.S. Output Voltage.....	6.5V
Storage Temperature.....	-65°C to +150°C
Soldering Information, Lead Temperature	
SOP Package	
Vapor Phase (60 seconds).....	215°C
Infrared (15 seconds).....	220°C
ESD Susceptibility	
Human Body Model.....	2000V
Machine	
Model.....	200V

Operating Ratings

Specified Temperature Range.....	T _{MIN} to T _{MAX}
	-55°C to +125°C
Supply Voltage Range (+Vs).....	+3.0V to +5.5V

Temperature-to-Digital Converter Characteristics

Unless otherwise noted, these specifications apply for +Vs=+3.3V Vdc. **Boldface limits apply for T_A=T_J=T_{MIN} to T_{MAX}**; all other limits T_A=T_J= +25°C, unless otherwise noted.

PARAMETER	CONDITIONS	TYPICAL	LIMITS	UNITS
Accuracy	TA=-25°C to +100°C		±2.0	°C (max)
	TA=-55°C to +125°C		±3.0	
Resolution		9		Bits
Temperature Conversion Time		100		Ms
Quiescent Current	SMBus Inactive	0.25	1.0	Ma
	SMBus Active			mA (max)
	Shutdown Mode	1		µA
O.S. Output Saturation Voltage	I _{OUT} = 4.0mA		0.8	V (max)
O.S. Delay			1	Conversions (min)
			6	Conversions (max)
T _{OS} Default Temperature G751-1/G751-2		50/80		°C
T _{HYST} Default Temperature G751-1/G751-2		45/75		°C

Block Diagram

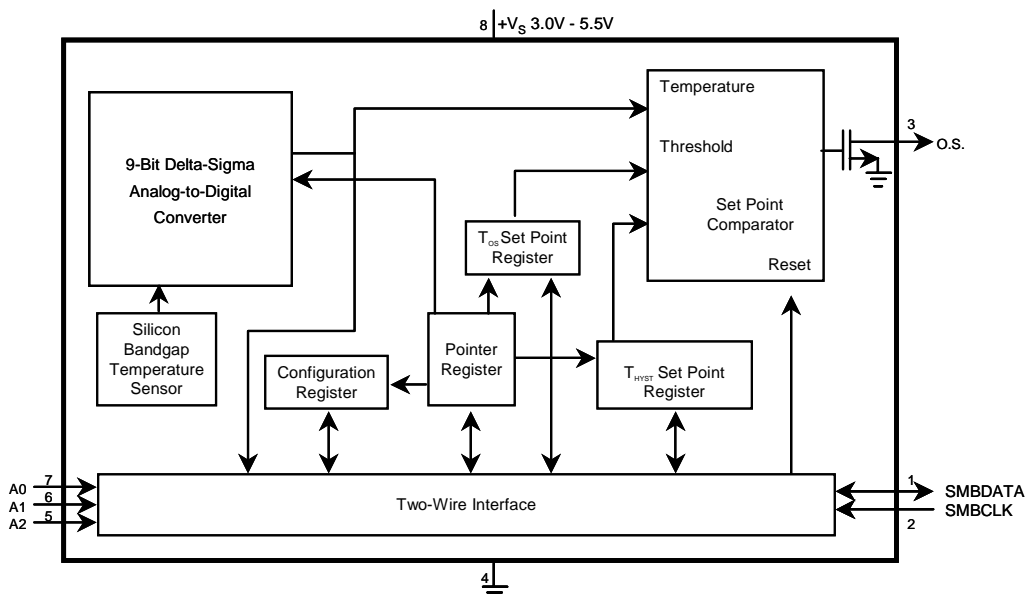



Logic Electrical Characteristics

Digital DC Characteristics

Unless otherwise noted, these specifications apply for +Vs=+3.3 Vdc. **Boldface limits apply for $T_A=T_J=T_{MIN}$ to T_{MAX}** ; all other limits $T_A=T_J=+25^{\circ}C$, unless otherwise noted.

SYMBOL	PARAMETER	CONDITIONS	TYPICAL	LIMITS	UNITS
$V_{IN(1)}$	Logical "1" Input Voltage			+Vs x 0.7 +Vs + 0.5	V (min) V (max)
$V_{IN(0)}$	Logical "0" Input Voltage			-0.3 +Vs x 0.3	V (min) V (max)
$I_{IN(1)}$	Logical "1" Input Current	$V_{IN}=5V$	0.005	1.0	μA
$I_{IN(0)}$	Logical "0" Input Current	$V_{IN}=0V$	-0.005	-1.0	μA
C_{IN}	All Digital Inputs		20		PF
I_{OH}	High Level Output Current	$V_{OH}=5V$		100	μA (max)
V_{OL}	Low Level Output Voltage	$I_{OL}=3ma$		0.4	V (max)
t_{OF}	Output Fall Time	$C_L=400pF, I_O=3ma$		250	ns (max)

SMBus Digital Switching Characteristics

Unless otherwise noted, these specifications apply for +Vs = +3.3 Vdc and C_L (load capacitance) on output lines = 80pF unless otherwise specified. **Boldface limits apply for $T_A = T_J = T_{MIN}$ to T_{MAX}** ; all other limits $T_A = T_J = +25^{\circ}C$, unless otherwise noted.

The switching characteristics of the G751 fully meet or exceed the published specifications of the SMBus. The following parameters are the timing relationships between SMBCLK and SMBDATA signals related to the G751. They are not the SMBus specifications.

SYMBOL	PARAMETER	CONDITIONS	TYPICAL	LIMITS	UNITS
t_1	SMBCLK (Clock) Period			2.5	μs (min)
t_2	Data in Set-Up Time to SMBCLK High			100	ns (min)
t_3	Data Out Stable after SMBCLK Low			0	ns (min)
t_4	SMBDATA Low Set-Up Time to SMBCLK Low (Start Condition)			100	ns (min)
t_5	SMBDATA High Hold Time after SMBCLK High (Stop Condition)			100	ns (min)

Pin Description

PIN	LABEL	FUNCTION	TYPICAL CONNECTION
1	SMBDATA	SMBus Serial Bi-Directional Data Line	From Controller
2	SMBCLK	SMBus Clock Input	From Controller
3	O.S.	Overtemperature Shutdown Open Drain Output	Pull Up Resistor, Controller Interrupt Line
4	GND	Power Supply Ground	Ground
5,6,7	A0-A2	User-Set SMBus Address Inputs	Ground (Low, "0") or +Vs (High, "1")
8	+Vs	Positive Supply Voltage Input	DC Voltage from 3V to 5.5V

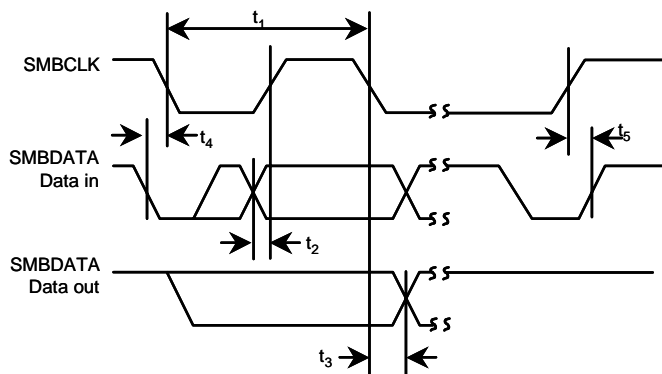

Logic Electrical Characteristics

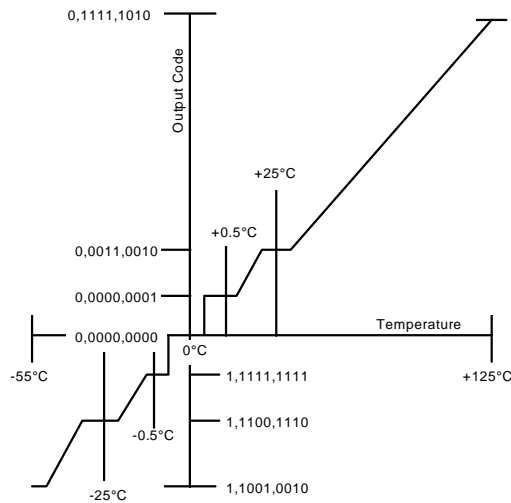

Temperature-to-Digital Transfer Function (Non-linear scale for clarity)

Functional Description

The G751 temperature sensor incorporates a band-gap type temperature sensor and 9-bit ADC (Delta-Sigma Analog- to-Digital Converter). The temperature data output of the G751 is available at all times via the SMBus. If a conversion is in progress, it will be stopped and restarted after the read. A digital comparator is also incorporated that compares a series of readings, the number of which is user-selectable, to user-programmable setpoint and hysteresis values. The comparator trips the O.S. output line, which is programmable for mode and polarity.

O.S. Output, T_{OS} and T_{HYST} Limits

In Comparator mode the O.S. Output behaves like a thermostat. The output becomes active when temperature exceeds the T_{OS} limit, and leaves the active state when the temperature drops below the T_{HYST} limit. In this mode the O.S. output can be used to turn a cooling fan on, initiate an emergency system shutdown, or reduce system clock speed. Shutdown mode does not reset O.S. state in a comparator mode.

In interrupt mode exceeding T_{OS} also makes O.S. active but O.S. will remain active indefinitely until reset by reading any register via the SMBus interface. Once O.S. has been activated by crossing T_{OS}, then reset, it can be activated again only by Temperature going below T_{HYST}. Again, it will remain active indefinitely until being reset by a read. Placing the G751 in shutdown mode also resets the O.S. output.

Default Modes

G751 always powers up in a known state. G751 power up default conditions are:

1. Comparator mode
2. T_{OS} set to 50°C for G751-1, to 80°C for G751-2
3. T_{HYST} set to 45°C for G751-1, to 75°C for G751-2
4. O.S. active low
5. Pointer set to "00"; Temperature Register

With these operating conditions G751 can act as a stand-alone thermostat with the above temperature settings. Connection to an SMBus is not required.

SMBus Interface

The G751 operates as a slave on the SMBus, so the SMBCLK line is an input (no clock is generated by the G751) and the SMBDATA line is a bi-directional serial data path. According to SMBus specifications, the G751 has a 7-bit slave address. The four most significant bits of the slave address are hard wired inside the G751 and are "1001". The three least significant bits of the address are assigned to pins A2-A0, and are set by connecting these pins to ground for a low, (0); or to +Vs for a high, (1).

Therefore, the complete slave address is:

1	0	0	1	A2	A1	A0
MSB				LSB		

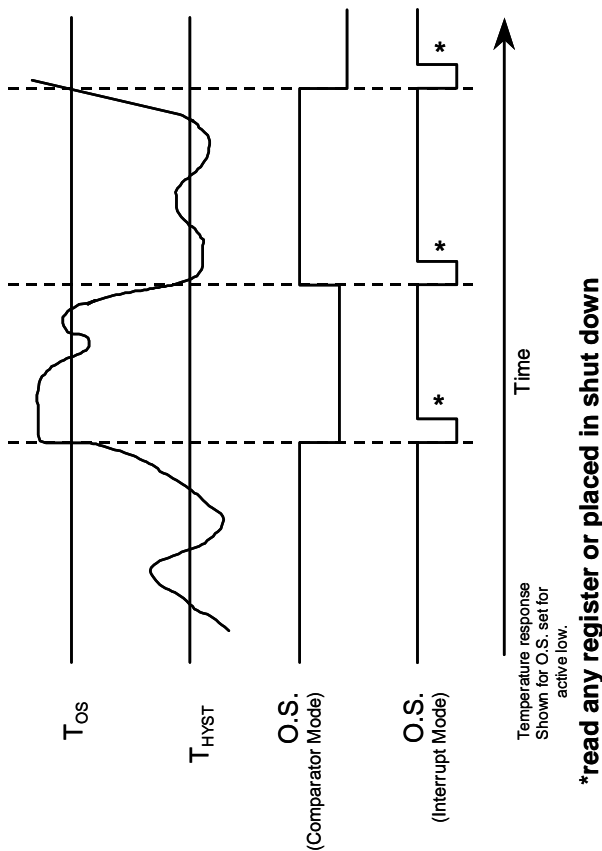

Figure1 O.S. Output Temperature Response Diagram

Temperature Data Format

Temperature data can be read from the Temperature, T_{OS} Set Point, and T_{HYST} Set Point registers; and written to the T_{OS} Set Point, and T_{HYST} Set Point registers. Temperature data is represented by a 9-bit, two's complement word with an LSB (Least Significant Bit) equal to 0.5°C:

TEMPERATURE	DIGITAL OUTPUT	
	BINARY	HEX
+125°C	0 1111 1010	0FAh
+25°C	0 0011 0010	032h
+0.5°C	0 0000 0001	001h
0°C	0 0000 0000	000h
-0.5°C	1 1111 1111	1FFh
-25°C	1 1100 1110	1CEh
-55°C	1 1001 0010	192h

Shutdown Mode

Shutdown mode is enabled by setting the shutdown bit in the Configuration register via the SMBus. Shutdown mode reduces power supply current to 1 μ A typical. In interrupt mode O.S. is reset if previously set and is undefined in Comparator mode during shutdown. The SMBus interface remains active. Activity on the clock and data lines of the SMBus may slightly increase shutdown mode quiescent current. T_{OS} , T_{HYST} , and Configuration registers can be read from and written to in shutdown mode.

Fault Queue

A fault queue of up to 6 faults is provided to prevent false tripping of O.S. when the G751 is used in noisy environments. The number of faults set in the queue must occur consecutively to set the O.S. output.

Comparator/Interrupt Mode

As indicated in the O.S. Output Temperature Response Diagram, Figure 1, the events that trigger O.S. are identical for either Comparator or Interrupt mode. The most important difference is that in Interrupt mode the O.S. will remain set indefinitely once it has been set. To reset O.S. while in Interrupt mode, perform a read from any register in the G751.

O.S. Output

The O.S. output is an open-drain output and does not have an internal pull-up. A "high" level will not be observed on this pin until pull-up current is provided from some external source, typically a pull-up resistor. Choice of resistor value depends on many system factors but, in general, the pull-up resistor should be as large as possible. This will minimize any errors due to internal heating of the G751. The maximum resistance of the pull up, based on G751 specification for High Level Output Current, to provide a 2V high level, is 30k Ω .

O.S. Polarity

The O.S. output can be programmed via the configuration register to be either active low (default mode), or active high. In active low mode the O.S. output goes low when triggered exactly as shown on the O.S. Output Temperature Response Diagram, Figure 1. Active high simply inverts the polarity of the O.S. output.

Internal Register Structure

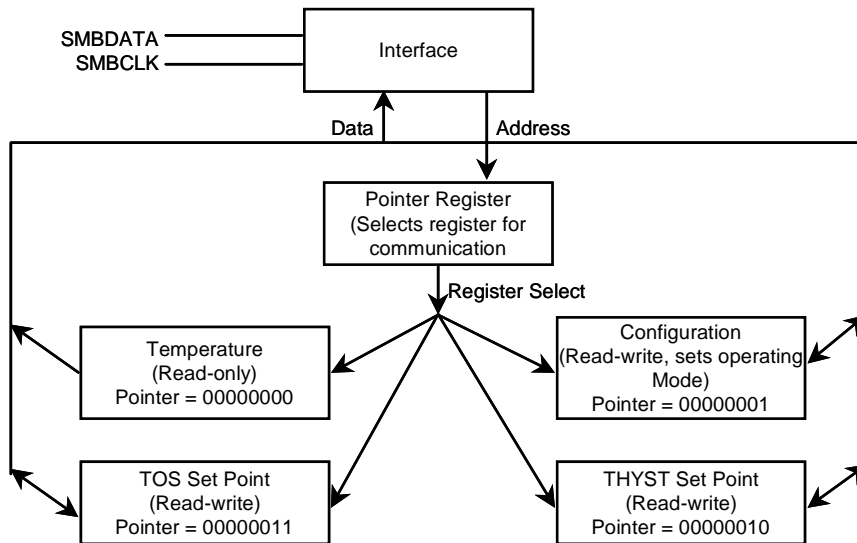

There are four data registers in the G751, selected by the Pointer register. At power-up the Pointer is set to "00"; the location for the Temperature Register. The Pointer register latches whatever the last location it was set to. In Interrupt Mode, a read from the G751, or placing the device in shutdown mode, resets the O.S. output. All registers are read and write, except the Temperature register which is read only.

A write to the G751 will always include the address byte and the Pointer byte. A write to the Configuration register requires one data byte, and the T_{OS} and T_{HYST} registers require two data bytes.

Reading the G751 can take place either of two ways: If the location latched in the Pointer is correct (most of the time it is expected that the Pointer will point to Temperature register because it will be the data most frequently read from the G751), then the read can simply consist of an address byte, followed by retrieving the corresponding number of data bytes. If the Pointer needs to be set, than an address byte, pointer byte, repeat start, and another address byte will accomplish a read.

The first data byte is the most significant byte with most signification bit first, permitting only as much data as necessary to be read to determine temperature condition. For instance, if the first four bits of the temperature data indicates an overtemperature condition, the host processor could immediately take action to remedy the excessive temperatures. At the end of a read, the G751 can accept either Acknowledge or No Acknowledge from the Master (No Acknowledge is typically used as a signal for the slave that the Master has read its last byte).

An inadvertent 8-bit read from a 16-bit register, with the D7 bit low, can cause the G751 to stop in a state where the SDA line is held low as shown in Figure 2. This can prevent any further bus communication until at least 9 additional clock cycles have occurred. Alternatively, the master can issue clock cycles until SDA goes high, at which time issuing a "Stop" condition will reset the G751.

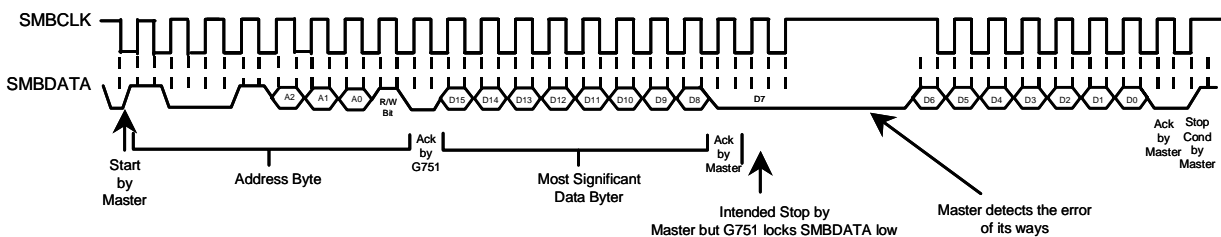

Figure 2. Inadvertent 8-Bit Read from 16-Bit Register where D7 is Zero

**Pointer Register**

(Selects which registers will be read from or written to):

P7	P6	P5	P4	P3	P2	P1	P0
0	0	0	0	0	0	Register Select	

P0-P1 :Register Select:

P1	P0	REGISTER
0	0	Temperature (Read only) (Power-up default)
0	1	Configuration (Read/Write)
1	0	T _{HYST} (Read/Write)
1	1	T _{OS} (Read/Write)

P2-P7 :Must be kept zero.

Temperature Register

(Read Only):

D15	D14	D13	D12	D11	D10	D9	D8	D7	D6	D5	D4	D3	D2	D1	D0
MSB	Bit 7	Bit 6	Bit 5	Bit 4	Bit 3	Bit 2	Bit 1	LSB	X	X	X	X	X	X	X

D0-D6 :Undefined

D7-D15 :Temperature Data. One LSB = 0.5°C. Two's complement format.

Configuration Register

(Read/Write):

D7	D6	D5	D4	D3	D2	D1	D0
0	0	0	Fault Queue		O.S. Polarity	Cmp/Int	Shutdown

Power up default is with all bits "0" (zero).

D0 :Shutdown : When set to 1 the G751 goes to low power shutdown mode.

D1 :Comparator / Interrupt mode : 0 is Comparator mode, 1 is Interrupt mode.

D2 :O.S. Polarity : 0 is active low, 1 is active high. O.S. is an open-drain output under all conditions.

D3-D4 :Fault Queue : Number of faults necessary to detect before setting O.S. output to avoid false tripping due to noise :

D4	D3	NUMBER OF FAULTS
0	0	1 (Power-up default)
0	1	2
1	0	4
1	1	6

D5-D7 :These bits are used for production testing and must be kept zero for normal operation.

T_{HYST} and T_{OS} Register

(Read/Write):

D15	D14	D13	D12	D11	D10	D9	D8	D7	D6	D5	D4	D3	D2	D1	D0
MSB	Bit 7	Bit 6	Bit 5	Bit 4	Bit 3	Bit 2	Bit 1	LSB	X	X	X	X	X	X	X

D0-D6 :Undefined

D7-D15 :T_{HYST} Or T_{OS} Trip Temperature Data. Power up default is T_{OS} = 50°C /80°C for G751-1/G751-2, T_{HYST} = 45°C /75°C for G751-1/G751-2.



SMBus Timing Diagrams

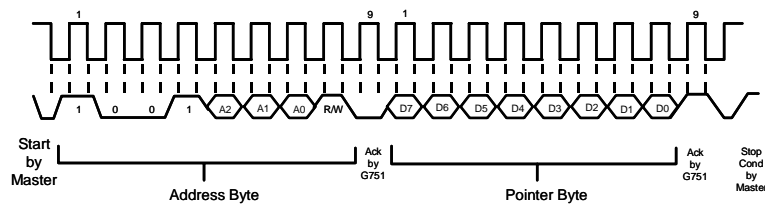
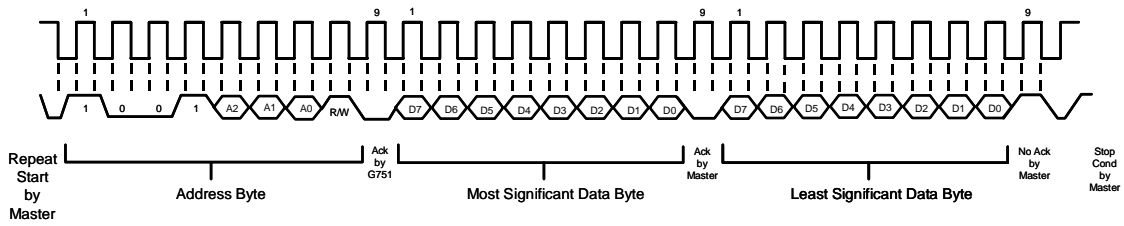
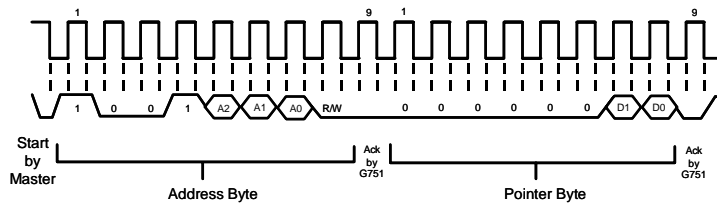
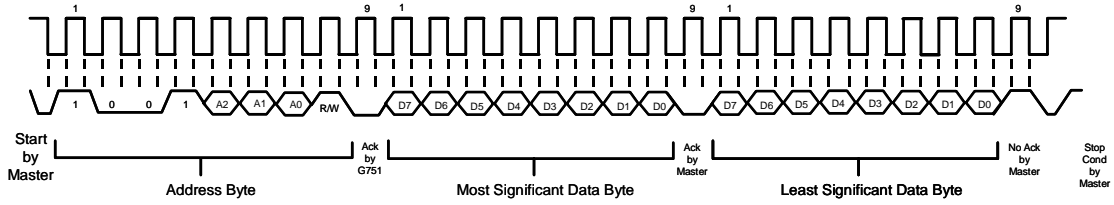



Timing Diagrams (Continued)

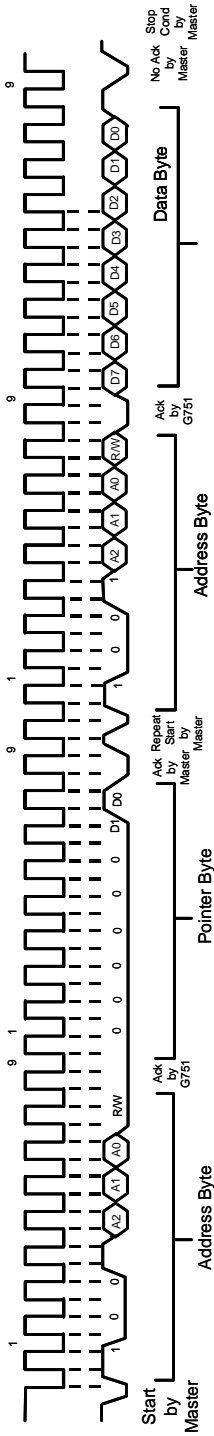

(a) Typical Pointer Set followed by Immediate Read from Configuration Register

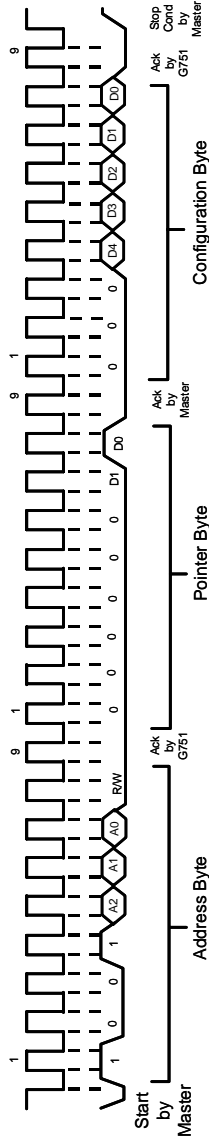

(b) Configuration Register Write

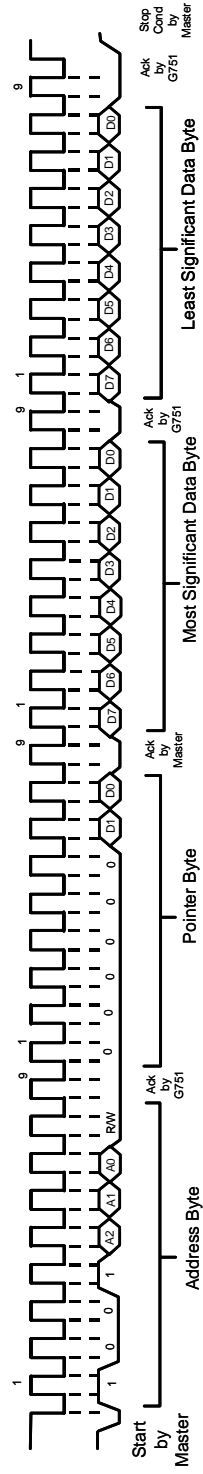

(c) T_{OS} and T_{HYST} Write

Package Information

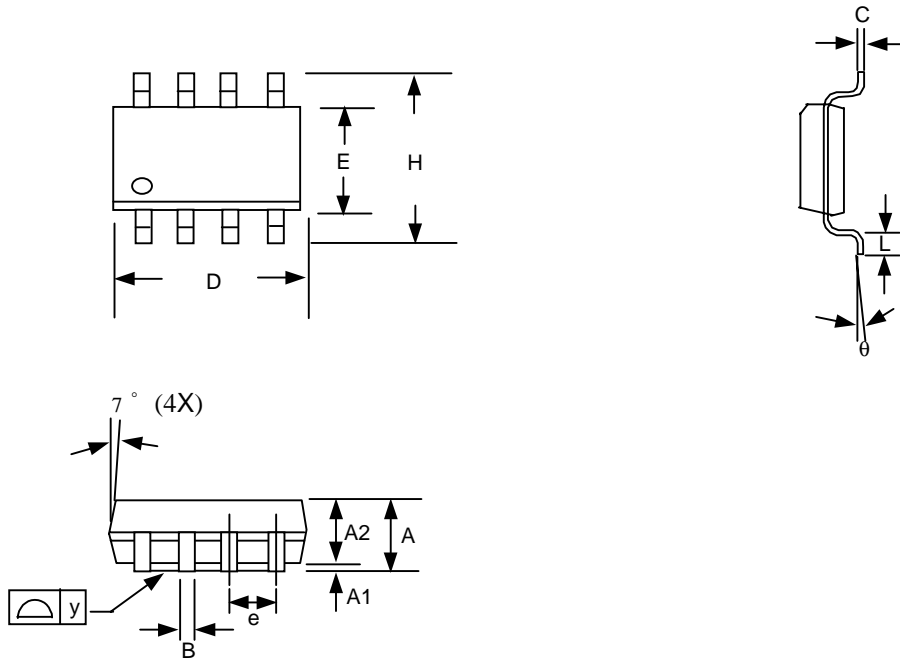

Note:

1. Package body sizes exclude mold flash and gate burrs
2. Dimension L is measured in gage plane
3. Tolerance 0.10mm unless otherwise specified
4. Controlling dimension is millimeter converted inch dimensions are not necessarily exact.

SYMBOL	DIMENSION IN MM			DIMENSION IN INCH		
	MIN.	NOM.	MAX.	MIN.	NOM.	MAX.
A	1.35	1.60	1.75	0.053	0.063	0.069
A1	0.10	-----	0.25	0.004	-----	0.010
A2	-----	1.45	-----	-----	0.057	-----
B	0.33	-----	0.51	0.013	-----	0.020
C	0.19	-----	0.25	0.007	-----	0.010
D	4.80	-----	5.00	0.189	-----	0.197
E	3.80	-----	4.00	0.150	-----	0.157
e	-----	1.27	-----	-----	0.050	-----
H	5.80	-----	6.20	0.228	-----	0.244
L	0.40	-----	1.27	0.016	-----	0.050
y	-----	-----	0.10	-----	-----	0.004
θ	0°	-----	8°	0°	-----	8°

Taping Specification

