

**FEATURES**

- accurate sync tip clamping ( $\pm 2$  mV typical)
- less than 1 mV clamping distortion
- variable clamping voltage ( $V_{EE} + 3$  V to  $V_{CC} - 4.5$  V)
- ultra low differential gain and differential phase
- less than  $\pm 0.15^\circ$  phase delay variation at 3.58 MHz
- $\pm 0.1$  dB flatness to 80 MHz
- $\pm 4.5$  to  $\pm 13.2$  V supply voltage range

**DESCRIPTION**

The GB4570 is a high performance video buffer/clamp used primarily for sync tip clamping of video signals. Key features include operation from  $\pm 4.5$  to  $\pm 13.2$  V supply voltages,  $\pm 0.1$  dB flatness to 80 MHz and availability of industry standard DIP and SOIC packages.

In a typical video application, the GB4570 clamps the sync tip to a known voltage. The clamping level can be set for normal sync tip clamping by connecting pin 3 to - 0.286 volts. For applications requiring non-standard sync tip clamping, the clamping voltage applied to pin 3 may be varied.

The GB4570 features a tight delay spread of only  $\pm 0.15^\circ$  at color burst frequencies and less than  $\pm 1$  millivolts clamping distortion.

**PIN CONNECTIONS**

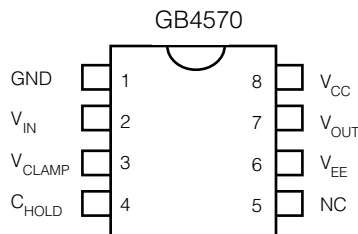

**APPLICATIONS**

- Sync tip clamping of NTSC, PAL, SECAM and RGB Video Signals
- Input buffering and clamping
- Inter-system video signal clamping

**AVAILABLE PACKAGING**

- 8 pin PDIP
- 8 pin SOIC

**SIMPLIFIED CIRCUIT DIAGRAM**

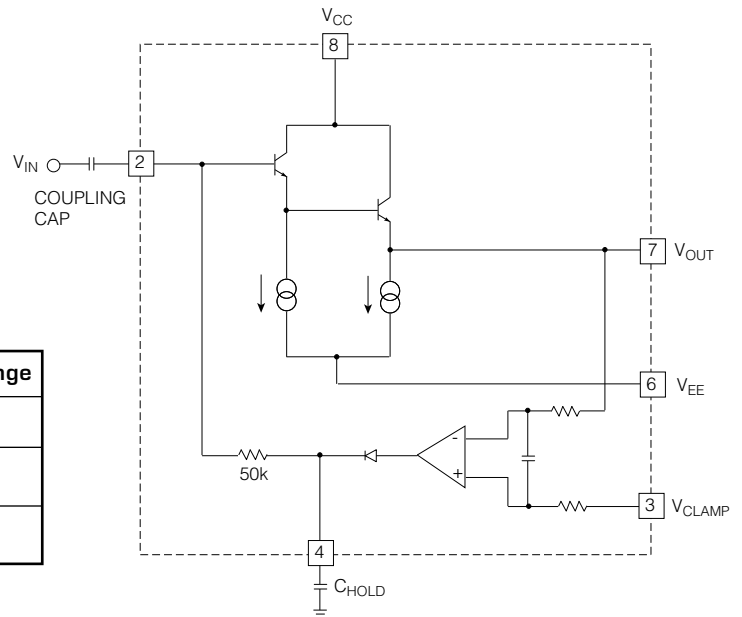

**ORDERING INFORMATION**

Part Number	Package	Temperature Range
GB4570-CDA	8 pin PDIP	0° to 70°C
GB4570-CKA	8 pin SOIC	0° to 70°C
GB4570-CTA	8 pin SOIC Tape	0° to 70°C

## ABSOLUTE MAXIMUM RATINGS

PARAMETER	VALUE/UNITS
Supply Voltage	$\pm 13.5$ V
Operating Temperature Range	$0^{\circ}\text{C} \leq T_A \leq 70^{\circ}\text{C}$
Storage Temperature Range	$-65^{\circ}\text{C} \leq T_S \leq 150^{\circ}\text{C}$
Lead Temperature (soldering, 10 seconds)	$260^{\circ}\text{C}$
Differential Video Input Voltage	$\pm 5$ V
Strobe Input Voltage	$-V_S \leq V_{\text{STROBE}} \leq +V_S$

**CAUTION**  
ELECTROSTATIC  
SENSITIVE DEVICES  
DO NOT OPEN PACKAGES OR HANDLE  
EXCEPT AT A STATIC-FREE WORKSTATION



## ELECTRICAL CHARACTERISTICS $V_S = \pm 5$ V, $T_A = 0^{\circ}$ to $70^{\circ}\text{C}$ , $R_L = 10\text{k}\Omega$ , $C_L = 10$ pF, unless otherwise shown.

	PARAMETER	SYMBOL	CONDITIONS	MIN	TYP	MAX	UNITS
POWER SUPPLIES	Supply Voltage	$\pm V_S$		$\pm 4.5$	$\pm 5$	$\pm 13.2$	V
	+ Supply Current	I+		-	9	14	mA
	- Supply Current	I-		-	9	14	mA
SIGNAL PATH	Small Signal B.W. (flattened response)	B.W.	$\pm 0.1$ dB after insertion loss, $V_{\text{IN}} = 100$ mV p-p	80	-	-	MHz
	Phase Delay	$\phi_d$	at 3.58 MHz and 4.43 MHz	-1.85	-2.0	-2.15	deg
	Differential Gain	$\partial g$	at 3.58 MHz and 4.43 MHz	-	0.01	0.02	%
	Differential Phase	$\partial p$	at 3.58 MHz and 4.43 MHz	-	0.01	0.02	deg
	Input Voltage	$V_{\text{IN}}$		$V_{\text{EE}} + 3\text{V}$	-	$V_{\text{CC}} - 3\text{V}$	V
	Input Resistance	$R_{\text{IN}}$		25	-	-	k $\Omega$
	Input Capacitance	$C_{\text{IN}}$		-	2.0	-	pF
	Output Resistance	$R_{\text{OUT}}$	$f = 0$ to $1$ MHz $f = 100$ MHz	- -	8.6 20	10 40	$\Omega$ $\Omega$
	Insertion Loss	I.L.	$f = 100$ kHz	-	0.03	0.05	dB
	Power Supply Rejection Ratio	PSRR	$f = 1$ kHz $f = 10$ MHz	50 30	- -	- -	dB dB
	PP Signal / RMS Noise	S/N	$V_{\text{SIG}} = 1$ Vp-p	75	-	-	dB
	Clamp Voltage Range	$V_{\text{CLAMP}}$	$V_{\text{IN}} = 1$ Vp-p,	$V_{\text{EE}} + 3.0$	-	$V_{\text{CC}} - 4.5$	V
	Accuracy		$V_{\text{IN}} = 0.5\text{V}$ to $2\text{Vp-p}$	-	$\pm 2$	$\pm 7$	mV
Clamping Distortion		Amplitude during sync	-	-	$\pm 1$	mV	

## DETAILED DESCRIPTION

The GB4570 is intended for video applications requiring DC restoration. The GB4570 signal path consists of a wideband Darlington emitter follower for maximum bandwidth performance. With this configuration, the GB4570's small signal frequency response remains within  $\pm 0.1$  dB of 0 dB out to 80 MHz.

Optimal frequency response for the GB4570 occurs with load capacitance in the range of 15 pF. For smaller loads, an external capacitor can be added to maximize the bandwidth of the device. As shown in Figure 1, a small resistor,  $R_{OUT}$ , should be included in series with the GB4570 output to obtain optimal response flatness. For a nominal load of 15 pF,  $R_{OUT}$  should be chosen to be approximately 40  $\Omega$ .

The DC restoration function is achieved through the use of a simple comparator. The non-inverting input of the comparator is connected to the clamp reference voltage, while the inverting input is connected to the GB4570 output. For output signals more positive than the clamp reference voltage, the comparator output is essentially open-circuit, while signal voltages more negative than the clamp reference voltage result in the charging of  $C_{HOLD}$ , an external non-polar capacitor connected to pin 4. The action of the comparator is to provide a positive current which is fed back to the input under conditions where the device output is more negative than the clamp reference voltage. This negative feedback raises the DC level of the input signal to the point where all signal fluctuations occur at voltages above the clamp reference voltage.

With this automatic adjustment system, the need for an external sync separator circuit to enable the clamping action is eliminated.

The input to the GB4570 must be AC coupled using an appropriately sized capacitor. This capacitor acts as a DC reservoir for corrective level shifts. Under equilibrium conditions, the average current supplied by the comparator output is just sufficient to balance the current discharging the input coupling capacitor. Under dynamic conditions, where the system is correcting for a change in the signal level, the charging current may be in the milliamp range. Since the corrective current is small under equilibrium conditions, the error voltage at the comparator input is also small making clamping to within  $\pm 2$  mV achievable.

The circuit makes use of a 'peak hold' capacitor,  $C_{HOLD}$ , at the output of the comparator. This gives rise to a more constant voltage at the comparator output. This constant voltage is translated to a more constant corrective current by an internal 50 k $\Omega$  resistor between the comparator output and the signal input.

To avoid excessive phase shifts and consequent instability of the clamp feedback loop, the peak hold capacitor should be considerably smaller (eg. 1000 times smaller) than the input coupling capacitor. If faster clamping is desirable, the peak hold capacitor can be removed and a smaller input coupling capacitor employed. In this application, some distortion of the signal tip will occur.

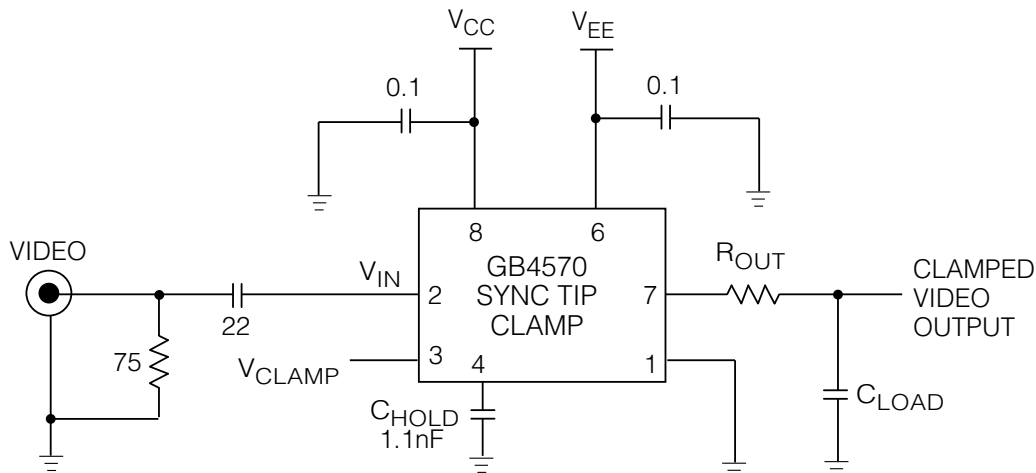

All resistors are in ohms, all capacitors in microfarads unless otherwise stated

Fig. 1 Typical Application Circuit

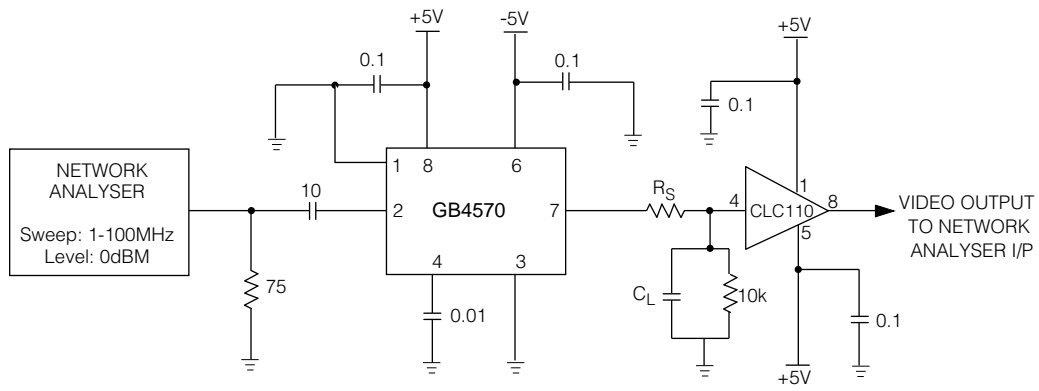

All resistors are in ohms, all capacitors in microfarads unless otherwise stated

Fig. 2 Frequency Response Test Circuit

**TYPICAL PERFORMANCE CURVES**

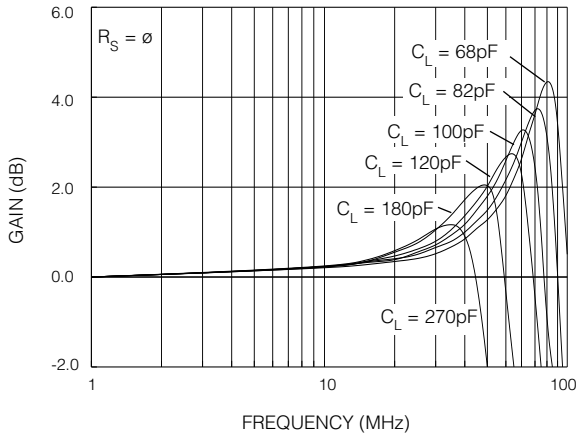

Fig. 3 GB4570 Frequency Response

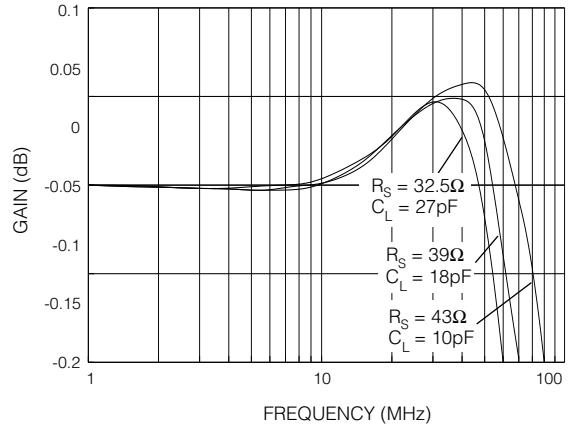

Fig. 4 Flattened Frequency Response

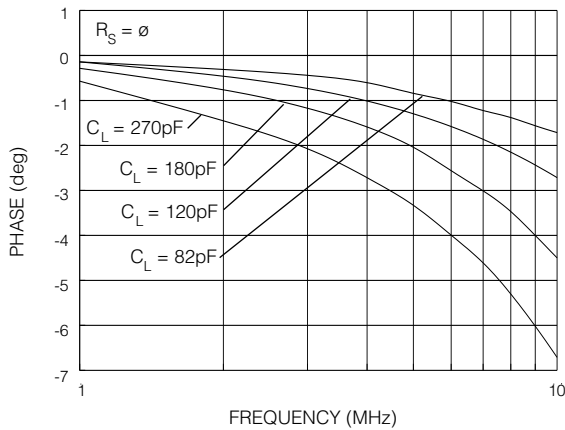

Fig. 5 Phase vs Frequency

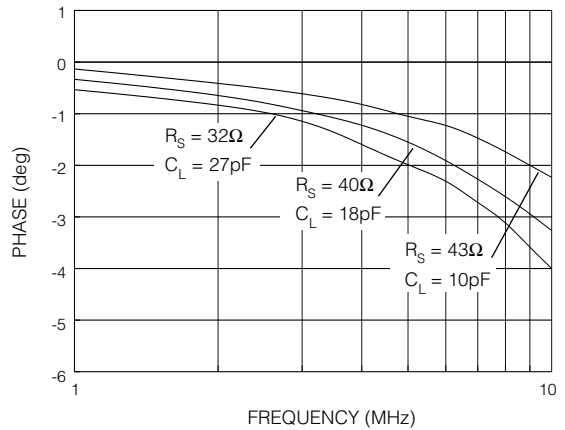

Fig. 6 Phase vs Frequency

**DOCUMENT  
IDENTIFICATION**

**PRODUCT PROPOSAL**

This data has been compiled for market investigation purposes only, and does not constitute an offer for sale.

**ADVANCE INFORMATION NOTE**

This product is in development phase and specifications are subject to change without notice. Gennum reserves the right to remove the product at any time. Listing the product does not constitute an offer for sale.

**PRELIMINARY DATA SHEET**

The product is in a preproduction phase and specifications are subject to change without notice.

**DATA SHEET**

The product is in production. Gennum reserves the right to make changes at any time to improve reliability, function or design, in order to provide the best product possible.