

# 50 kPa Uncompensated Silicon Pressure Sensors

The MPX53/MPXV53GC series silicon piezoresistive pressure sensors provide a very accurate and linear voltage output — directly proportional to the applied pressure. These standard, low cost, uncompensated sensors permit manufacturers to design and add their own external temperature compensating and signal conditioning networks. Compensation techniques are simplified because of the predictability of Motorola's single element strain gauge design.

**Features**

- Low Cost
- Patented Silicon Shear Stress Strain Gauge Design
- Ratiometric to Supply Voltage
- Easy to Use Chip Carrier Package Options
- 60 mV Span (Typ)
- Differential and Gauge Options

**Application Examples**

- Air Movement Control
- Environmental Control Systems
- Level Indicators
- Leak Detection
- Medical Instrumentation
- Industrial Controls
- Pneumatic Control Systems
- Robotics

Figure 1 shows a schematic of the internal circuitry on the stand-alone pressure sensor chip.

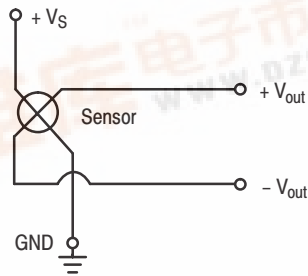

**Figure 1. Uncompensated Pressure Sensor Schematic**

**VOLTAGE OUTPUT versus APPLIED DIFFERENTIAL PRESSURE**

The differential voltage output of the sensor is directly proportional to the differential pressure applied.

The output voltage of the differential or gauge sensor increases with increasing pressure applied to the pressure side (P1) relative to the vacuum side (P2). Similarly, output voltage increases as increasing vacuum is applied to the vacuum side (P2) relative to the pressure side (P1).

Replaces MPX50/D

## MPX53 MPXV53GC SERIES

0 to 50 kPa (0–7.25 psi)  
 60 mV FULL SCALE SPAN  
 (TYPICAL)

**SMALL OUTLINE  
PACKAGE**

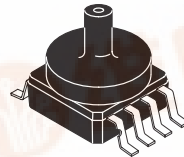

**MPXV53GC6U  
CASE 482A**

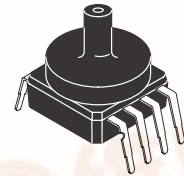

**MPXV53GC7U  
CASE 482C**

NOTE: Pin 1 is the notched pin.

PIN NUMBER			
1	Gnd	5	N/C
2	+V <sub>out</sub>	6	N/C
3	V <sub>S</sub>	7	N/C
4	-V <sub>out</sub>	8	N/C

**UNIBODY PACKAGE**

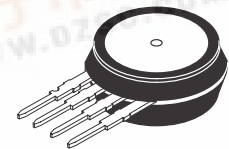

**MPX53D  
CASE 344**

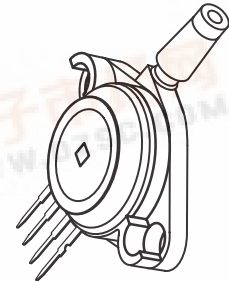

**MPX53GP  
CASE 344B**

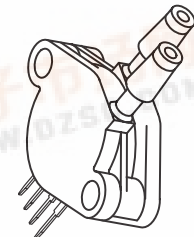

**MPX53DP  
CASE 344C**

NOTE: Pin 1 is the notched pin.

PIN NUMBER			
1	Gnd	3	V <sub>S</sub>
2	+V <sub>out</sub>	4	-V <sub>out</sub>

## MPX53 MPXV53GC SERIES

### MAXIMUM RATINGS(NOTE)

Rating	Symbol	Value	Unit
Maximum Pressure (P1 > P2)	$P_{max}$	200	kPa
Storage Temperature	$T_{stg}$	-40 to +125	°C
Operating Temperature	$T_A$	-40 to +125	°C

NOTE: Exposure beyond the specified limits may cause permanent damage or degradation to the device.

### OPERATING CHARACTERISTICS ( $V_S = 3.0$ Vdc, $T_A = 25^\circ\text{C}$ unless otherwise noted, P1 > P2)

Characteristic	Symbol	Min	Typ	Max	Unit
Pressure Range <sup>(1)</sup>	$P_{OP}$	0	—	50	kPa
Supply Voltage <sup>(2)</sup>	$V_S$	—	3.0	6.0	Vdc
Supply Current	$I_o$	—	6.0	—	mAdc
Full Scale Span <sup>(3)</sup>	$V_{FSS}$	45	60	90	mV
Offset <sup>(4)</sup>	$V_{off}$	0	20	35	mV
Sensitivity	$\Delta V/\Delta P$	—	1.2	—	mV/kPa
Linearity <sup>(5)</sup>	—	-0.6	—	0.4	% $V_{FSS}$
Pressure Hysteresis <sup>(5)</sup> (0 to 50 kPa)	—	—	$\pm 0.1$	—	% $V_{FSS}$
Temperature Hysteresis <sup>(5)</sup> (-40°C to +125°C)	—	—	$\pm 0.5$	—	% $V_{FSS}$
Temperature Coefficient of Full Scale Span <sup>(5)</sup>	$TCV_{FSS}$	-0.22	—	-0.16	% $V_{FSS}/^\circ\text{C}$
Temperature Coefficient of Offset <sup>(5)</sup>	$TCV_{off}$	—	$\pm 15$	—	$\mu\text{V}/^\circ\text{C}$
Temperature Coefficient of Resistance <sup>(5)</sup>	$TCR$	0.31	—	0.37	% $Z_{in}/^\circ\text{C}$
Input Impedance	$Z_{in}$	355	—	505	$\Omega$
Output Impedance	$Z_{out}$	750	—	1875	$\Omega$
Response Time <sup>(6)</sup> (10% to 90%)	$t_R$	—	1.0	—	ms
Warm-Up	—	—	20	—	ms
Offset Stability <sup>(7)</sup>	—	—	$\pm 0.5$	—	% $V_{FSS}$

#### NOTES:

- 1.0 kPa (kiloPascal) equals 0.145 psi.
- Device is ratiometric within this specified excitation range. Operating the device above the specified excitation range may induce additional error due to device self-heating.
- Full Scale Span ( $V_{FSS}$ ) is defined as the algebraic difference between the output voltage at full rated pressure and the output voltage at the minimum rated pressure.
- Offset ( $V_{off}$ ) is defined as the output voltage at the minimum rated pressure.
- Accuracy (error budget) consists of the following:
  - Linearity: Output deviation from a straight line relationship with pressure, using end point method, over the specified pressure range.
  - Temperature Hysteresis: Output deviation at any temperature within the operating temperature range, after the temperature is cycled to and from the minimum or maximum operating temperature points, with zero differential pressure applied.
  - Pressure Hysteresis: Output deviation at any pressure within the specified range, when this pressure is cycled to and from the minimum or maximum rated pressure, at 25°C.
  - TcSpan: Output deviation at full rated pressure over the temperature range of 0 to 85°C, relative to 25°C.
  - TcOffset: Output deviation with minimum rated pressure applied, over the temperature range of 0 to 85°C, relative to 25°C.
  - TCR:  $Z_{in}$  deviation with minimum rated pressure applied, over the temperature range of -40°C to +125°C, relative to 25°C.
- Response Time is defined as the time for the incremental change in the output to go from 10% to 90% of its final value when subjected to a specified step change in pressure.
- Offset stability is the product's output deviation when subjected to 1000 hours of Pulsed Pressure, Temperature Cycling with Bias Test.

## MPX53 MPXV53GC SERIES

### TEMPERATURE COMPENSATION

Figure 2 shows the typical output characteristics of the MPX53/MPXV53GC series over temperature.

The piezoresistive pressure sensor element is a semiconductor device which gives an electrical output signal proportional to the pressure applied to the device. This device uses a unique transverse voltage diffused semiconductor strain gauge which is sensitive to stresses produced in a thin silicon diaphragm by the applied pressure.

Because this strain gauge is an integral part of the silicon diaphragm, there are no temperature effects due to differences in the thermal expansion of the strain gauge and the diaphragm, as are often encountered in bonded strain gauge pressure sensors. However, the properties of the strain gauge itself are temperature dependent, requiring that the device be temperature compensated if it is to be used over an extensive temperature range.

Temperature compensation and offset calibration can be achieved rather simply with additional resistive components,

or by designing your system using the MPX2053 series sensors.

Several approaches to external temperature compensation over both  $-40$  to  $+125^{\circ}\text{C}$  and  $0$  to  $+80^{\circ}\text{C}$  ranges are presented in Motorola Applications Note AN840.

### LINEARITY

Linearity refers to how well a transducer's output follows the equation:  $V_{\text{out}} = V_{\text{off}} + \text{sensitivity} \times P$  over the operating pressure range (see Figure 3). There are two basic methods for calculating nonlinearity: (1) end point straight line fit or (2) a least squares best line fit. While a least squares fit gives the "best case" linearity error (lower numerical value), the calculations required are burdensome.

Conversely, an end point fit will give the "worst case" error (often more desirable in error budget calculations) and the calculations are more straightforward for the user. Motorola's specified pressure sensor linearities are based on the end point straight line method measured at the midrange pressure.

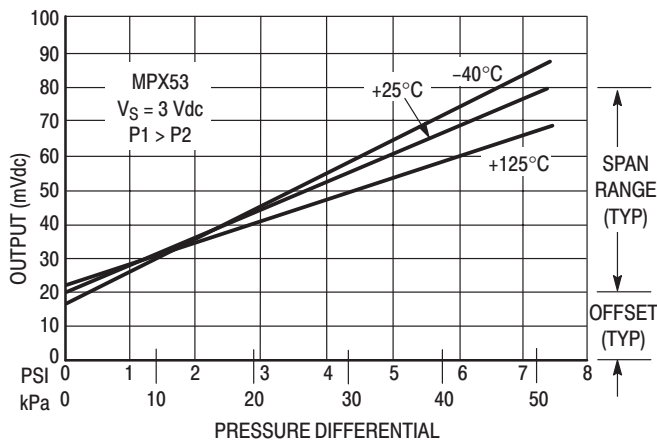

Figure 2. Output versus Pressure Differential

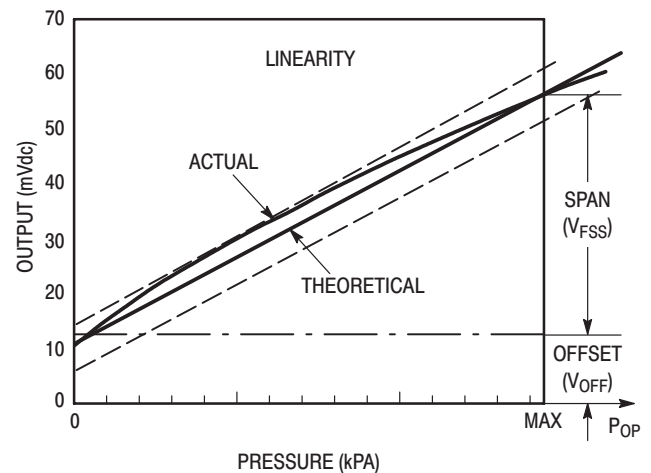

Figure 3. Linearity Specification Comparison

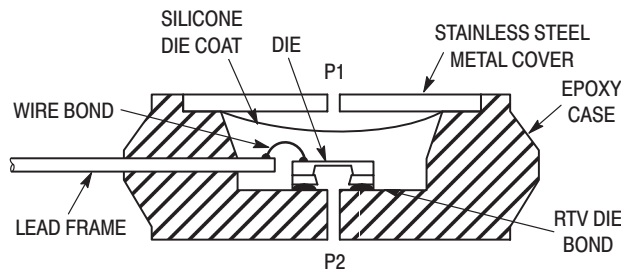

Figure 4. Cross-Sectional Diagram (not to scale)

Figure 4 illustrates the differential or gauge configuration in the unibody chip carrier (Case 344). A silicone gel isolates the die surface and wire bonds from the environment, while allowing the pressure signal to be transmitted to the silicon diaphragm.

The MPX53/MPXV53GC series pressure sensor operating

characteristics and internal reliability and qualification tests are based on use of dry air as the pressure media. Media other than dry air may have adverse effects on sensor performance and long term reliability. Contact the factory for information regarding media compatibility in your application.

## MPX53 MPXV53GC SERIES

### PRESSURE (P1)/VACUUM (P2) SIDE IDENTIFICATION TABLE

Motorola designates the two sides of the pressure sensor as the Pressure (P1) side and the Vacuum (P2) side. The Pressure (P1) side is the side containing silicone gel which isolates the die from the environment. The Motorola pres-

sure sensor is designed to operate with positive differential pressure applied,  $P1 > P2$ .

The Pressure (P1) side may be identified by using the table below:

Part Number	Case Type	Pressure (P1) Side Identifier
MPX53D	344	Stainless Steel Cap
MPX53DP	344C	Side with Port Marking
MPX53GP	344B	Side with Port Attached
MPXV53GC series	482A, 482C	Sides with Port Attached

### ORDERING INFORMATION – UNIBODY PACKAGE

MPX53 series pressure sensors are available in differential and gauge configurations. Devices are available with basic element package or with pressure port fittings which provide printed circuit board mounting ease and barbed hose pressure connections.

Device Type	Options	Case Type	MPX Series	
			Order Number	Device Marking
Basic Element	Differential	Case 344	MPX53D	MPX53D
Ported Elements	Differential	Case 344C	MPX53DP	MPX53DP
	Gauge	Case 344B	MPX53GP	MPX53GP

### ORDERING INFORMATION — SMALL OUTLINE PACKAGE

The MPXV53GC series pressure sensors are available with a pressure port, surface mount or DIP leadforms, and two packing options.

Device Order No.	Case No.	Packing Options	Marking
MPXV53GC6T1	482A	Tape & Rail	MPXV53G
MPXV53GC6U	482A	Rails	MPXV53G
MPXV53GC7U	482C	Rails	MPXV53G

# MPX53 MPXV53GC SERIES

## PACKAGE DIMENSIONS

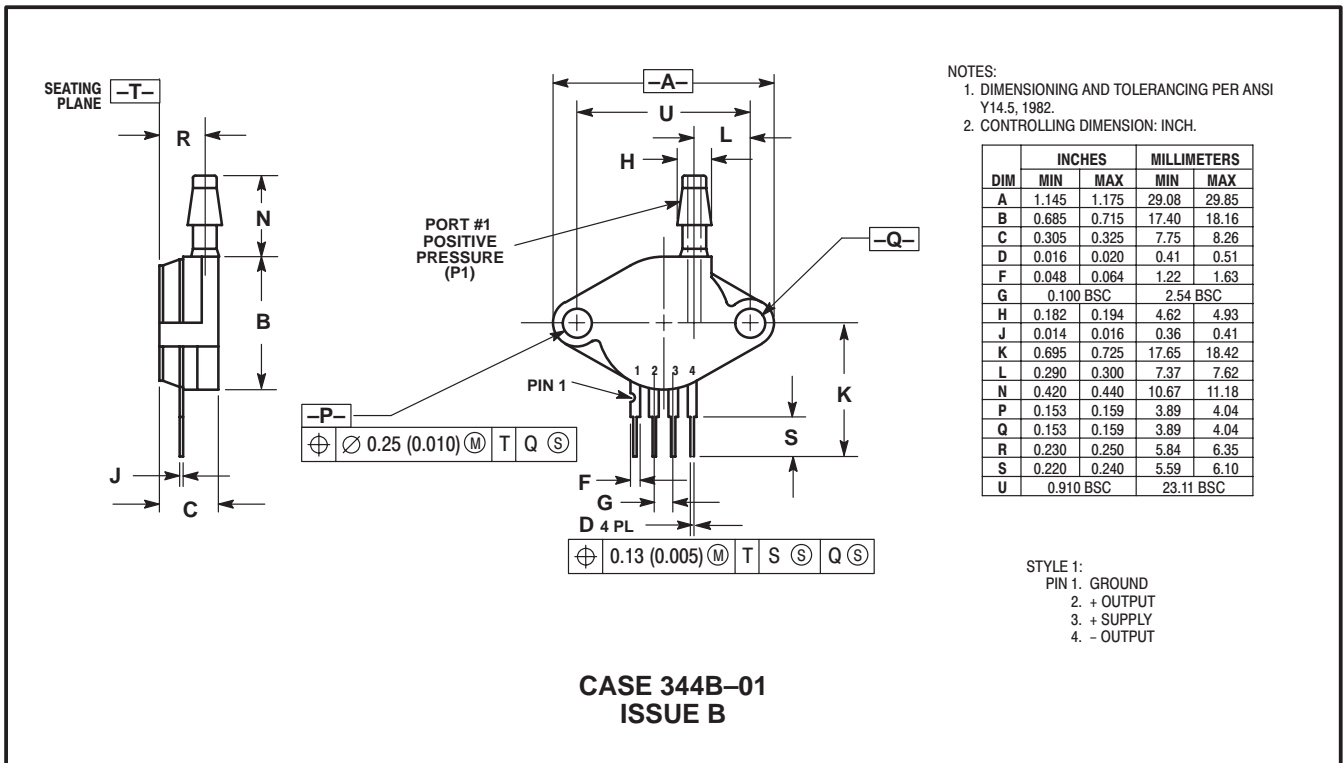
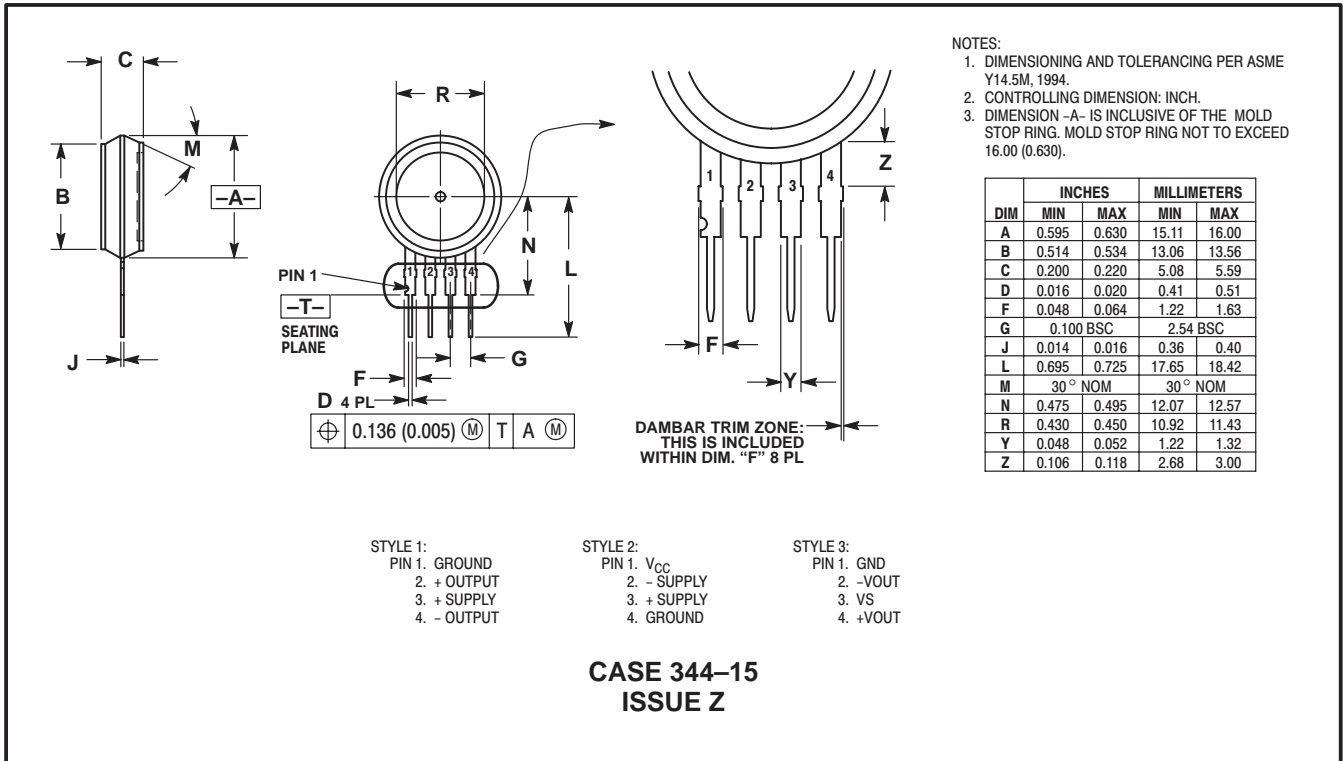

**MPX53 MPXV53GC SERIES**

**PACKAGE DIMENSIONS — CONTINUED**

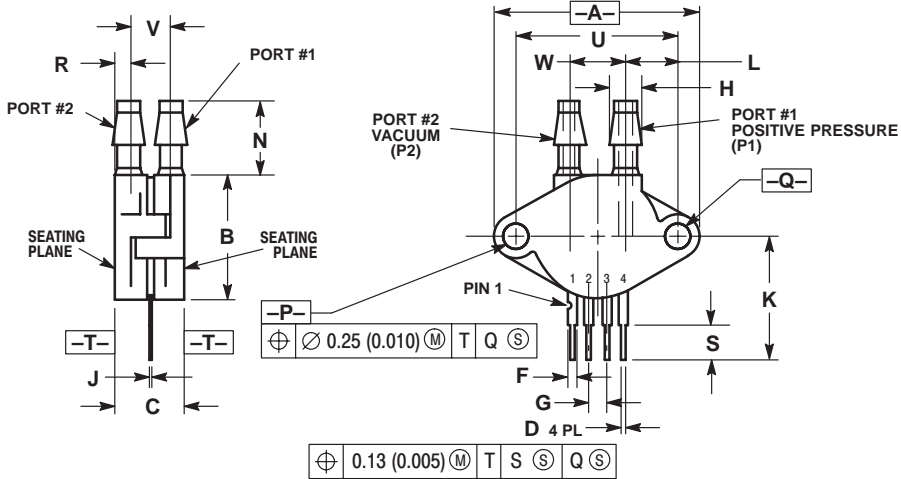

- NOTES:  
 1. DIMENSIONING AND TOLERANCING PER ANSI Y14.5M, 1982.  
 2. CONTROLLING DIMENSION: INCH.

DIM	INCHES		MILLIMETERS	
	MIN	MAX	MIN	MAX
A	1.145	1.175	29.08	29.85
B	0.685	0.715	17.40	18.16
C	0.405	0.435	10.29	11.05
D	0.016	0.020	0.41	0.51
F	0.048	0.064	1.22	1.63
G	0.100 BSC		2.54 BSC	
H	0.182	0.194	4.62	4.93
J	0.014	0.016	0.36	0.41
K	0.695	0.725	17.65	18.42
L	0.290	0.300	7.37	7.62
N	0.420	0.440	10.67	11.18
P	0.153	0.159	3.89	4.04
Q	0.153	0.159	3.89	4.04
R	0.063	0.083	1.60	2.11
S	0.220	0.240	5.59	6.10
U	0.910 BSC		23.11 BSC	
V	0.248	0.278	6.30	7.06
W	0.310	0.330	7.87	8.38

- STYLE 1:  
 PIN 1. GROUND  
 2. + OUTPUT  
 3. + SUPPLY  
 4. - OUTPUT

**CASE 344C-01  
 ISSUE B**

# MPX53 MPXV53GC SERIES

## SMALL OUTLINE PACKAGE DIMENSIONS

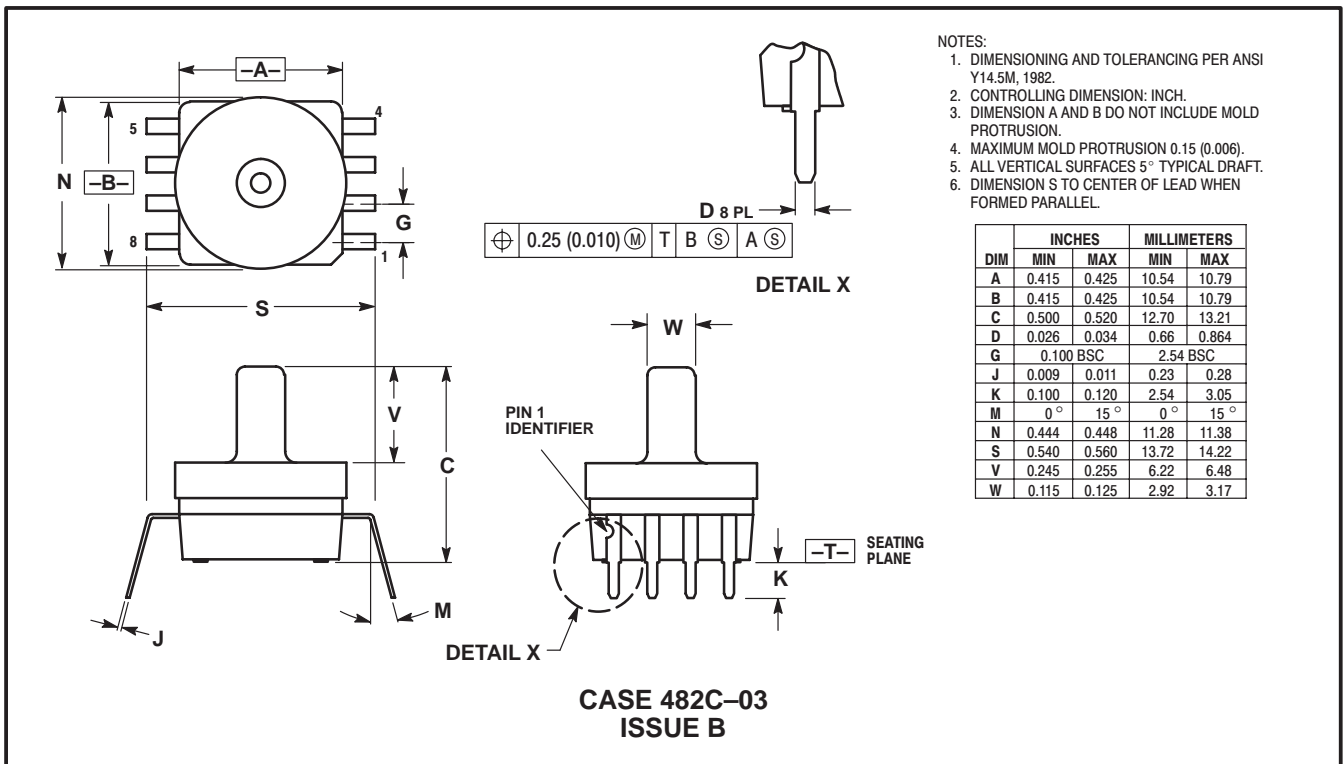
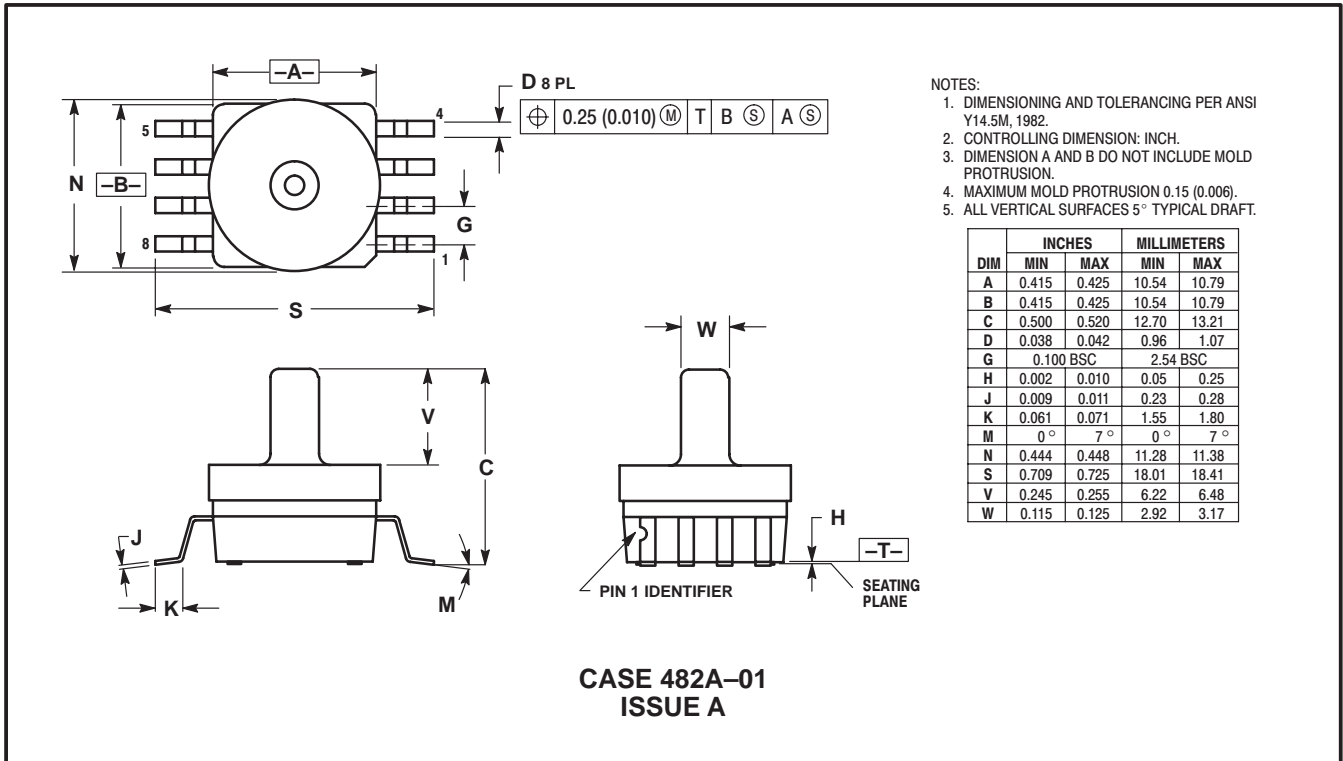

## MPX53 MPXV53GC SERIES

Motorola reserves the right to make changes without further notice to any products herein. Motorola makes no warranty, representation or guarantee regarding the suitability of its products for any particular purpose, nor does Motorola assume any liability arising out of the application or use of any product or circuit, and specifically disclaims any and all liability, including without limitation consequential or incidental damages. "Typical" parameters which may be provided in Motorola data sheets and/or specifications can and do vary in different applications and actual performance may vary over time. All operating parameters, including "Typicals" must be validated for each customer application by customer's technical experts. Motorola does not convey any license under its patent rights nor the rights of others. Motorola products are not designed, intended, or authorized for use as components in systems intended for surgical implant into the body, or other applications intended to support or sustain life, or for any other application in which the failure of the Motorola product could create a situation where personal injury or death may occur. Should Buyer purchase or use Motorola products for any such unintended or unauthorized application, Buyer shall indemnify and hold Motorola and its officers, employees, subsidiaries, affiliates, and distributors harmless against all claims, costs, damages, and expenses, and reasonable attorney fees arising out of, directly or indirectly, any claim of personal injury or death associated with such unintended or unauthorized use, even if such claim alleges that Motorola was negligent regarding the design or manufacture of the part. Motorola, Inc. Motorola, Inc. is an Equal Opportunity/Affirmative Action Employer. MOTOROLA and the  logo are registered in the US Patent & Trademark Office. All other product or service names are the property of their respective owners.

© Motorola, Inc. 2001.

### How to reach us:

**USA/EUROPE/Locations Not Listed:** Motorola Literature Distribution; P.O. Box 5405, Denver, Colorado 80217. 1-303-675-2140 or 1-800-441-2447

**JAPAN:** Motorola Japan Ltd.; SPS, Technical Information Center, 3-20-1, Minami-Azabu. Minato-ku, Tokyo 106-8573 Japan. 81-3-3440-3569

**ASIA/PACIFIC:** Motorola Semiconductors H.K. Ltd.; Silicon Harbour Centre, 2 Dai King Street, Tai Po Industrial Estate, Tai Po, N.T., Hong Kong. 852-26668334

**Technical Information Center: 1-800-521-6274**

**HOME PAGE:** <http://www.motorola.com/semiconductors/>

