

# M37902FCCHP, M37902FGCHP, M37902FJCHP

SINGLE-CHIP 16-BIT CMOS MICROCOMPUTER

## DESCRIPTION

These are single-chip microcomputers designed with high-performance CMOS silicon gate technology, including the internal flash memory. These microcomputers support the 7900 Series instruction set, which are enhanced and expanded instruction set and are up-per-compatible with the 7700/7751 Series instruction set.

The CPU of these microcomputers is a 16-bit parallel processor that can also be switched to perform 8-bit parallel processing. Also, the bus interface unit of these microcomputers enhances the memory access efficiency to execute instructions fast. Therefore, these microcomputers are suitable for office, business, and industrial equipment controller that require high-speed processing of large data.

For the internal flash memory, single-power-supply programming and erasure, using a PROM programmer or the control by the central processing unit (CPU), is supported. Also, each of these microcomputers has the memory area dedicated for storing a certain software which controls programming and erasure (reprogramming control software). Therefore, on these microcomputers, the program can easily be changed even after they are mounted on the board.

- Programming/Erase control by software command
- Maximum number of reprograms ..... 100

## APPLICATION

Control devices for personal computer peripheral equipment such as CD-ROM drives, DVD-ROM drives, hard disk drives, high density FDD, printers

## DISTINCTIVE FEATURES

<Microcomputer mode>

- Number of basic machine instructions ..... 203
- Memory
  - [M37902FCCHP]
    - Flash memory (User ROM area) ..... 120 Kbytes
    - RAM ..... 4096 bytes
  - [M37902FGCHP]
    - Flash memory (User ROM area) ..... 248 Kbytes
    - RAM ..... 6144 bytes
  - [M37902FJCHP]
    - Flash memory (User ROM area) ..... 498 Kbytes
    - RAM ..... 12288 bytes
- [All of the above computers]
  - Flash memory (Boot ROM area) ..... 16 Kbytes
- Instruction execution time
  - The fastest instruction at 26 MHz frequency ..... 38 ns
- Single power supply ..... 5 V ± 0.5 V
- Interrupts ..... 6 external sources, 16 internal sources, 7 levels
- Multi-functional 16-bit timer ..... 5 + 3
- Serial I/O (UART or Clock synchronous) ..... 2
- 10-bit A-D converter ..... 8-channel inputs
- 8-bit D-A converter ..... 3-channel outputs
- Real-time output
  - .... 4 bits × 2 channels, or 6 bits × 1 channel + 2 bits × 1 channel
- 12-bit watchdog timer
- Programmable input/output (ports P0-P8, P10, P11) ..... 84

<Flash memory mode>

- Power supply voltage ..... 5 V ± 0.5 V
  - Programming/Erase voltage ..... 5 V ± 0.5 V
  - Programming method ..... Programming in a unit of 256 bytes
  - Erase method ..... Block erase or Total erase
- (Data protection per block is enabled.)



MITSUBISHI MICROCOMPUTERS  
**M37902FCCHP, M37902FGCHP, M37902FJCHP**

SINGLE-CHIP 16-BIT CMOS MICROCOMPUTER

**M37902FxCHP PIN CONFIGURATION (TOP VIEW)**

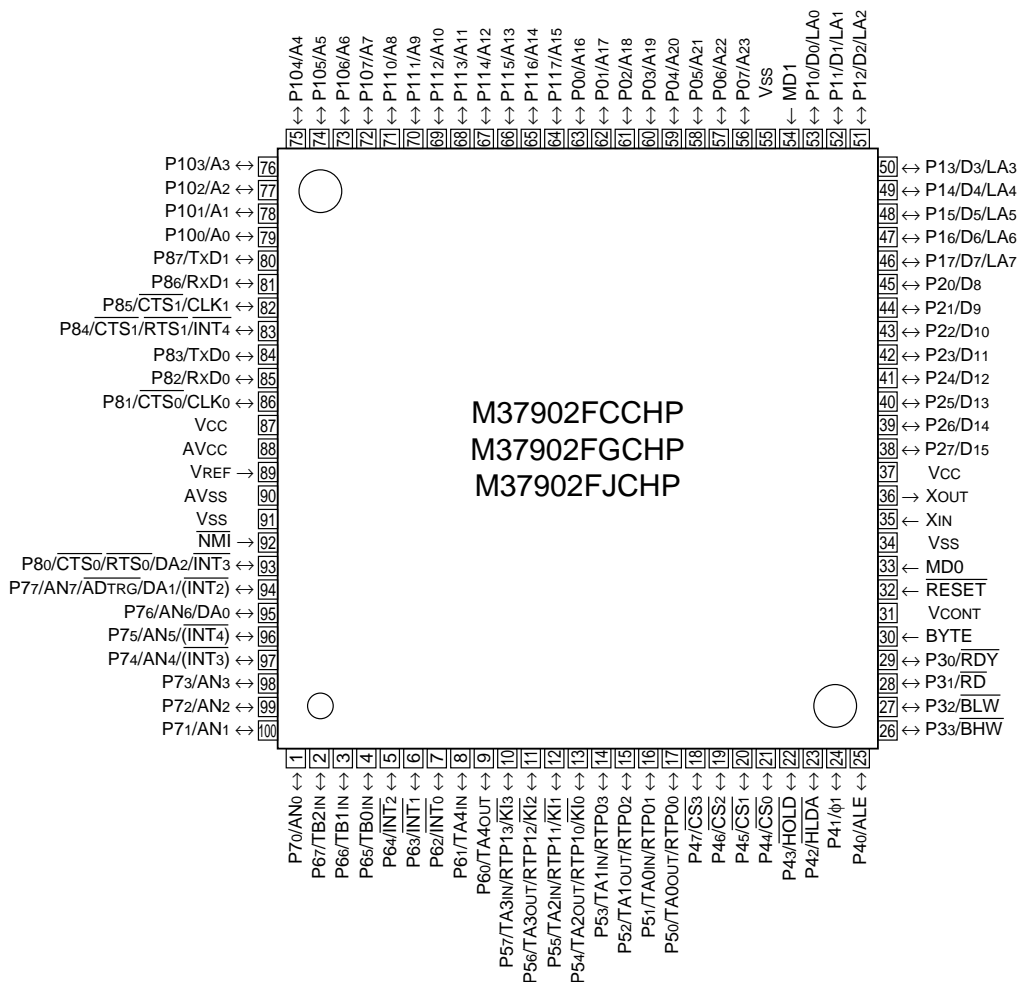

**Outline 100P6Q-A**



MITSUBISHI MICROCOMPUTERS

# M37902FCCHP, M37902FGCHP, M37902FJCHP

SINGLE-CHIP 16-BIT CMOS MICROCOMPUTER

## FUNCTIONS (Microcomputer mode)

Parameter		Functions
Number of basic machine instructions		203
Instruction execution time		38 ns (the fastest instruction at $f(f_{sys}) = 26$ MHz)
External clock input frequency $f(X_{IN})$		26 MHz (Max.)
System clock frequency $f(f_{sys})$		26 MHz (Max.)
Memory size	Flash memory (User ROM area)	<b>(Note)</b>
	RAM	<b>(Note)</b>
	Flash memory (Boot ROM area)	16 Kbytes
Programmable input/output ports	P0–P2, P4–P8, P10, P11	8-bit X 10
	P3	4-bit X 1
Multi-functional timers	TA0–TA4	16-bit X 5
	TB0–TB2	16-bit X 3
Serial I/O	UART0 and UART1	(UART or Clock synchronous serial I/O) X 2
A-D converter		10-bit successive approximation method X 1 (8 channels)
D-A converter		8-bit X 3
Watchdog timer		12-bit X 1
Chip-select wait control		Chip select area X 4 ( $\overline{CS_0}$ – $\overline{CS_3}$ ). A bus cycle type and bus width can be set for each chip select area.
Real-time output		4 bits X 2 channels; or 6 bits X 1 channel + 2 bits X 1 channel
Interrupts	Maskable interrupts	5 external types, 13 internal types. Each interrupt can be set to a priority level within the range of 0–7 by software.
	Non-maskable interrupts	1 external type, 3 internal types.
Clock generating circuit		Built-in (externally connected to a ceramic resonator or quartz crystal resonator).
PLL frequency multiplier		The following multiplication methods are available: double, triple, and quadruple.
Power supply voltage		5 V $\pm$ 0.5 V
Power dissipation		150 mW (at $f(f_{sys}) = 26$ MHz, Typ., PLL frequency multiplier stopped)
Ports' input/output characteristics	Input/Output withstand voltage	5 V
	Output current	5 mA
Memory expansion		Up to 16 Mbytes. Note that bank FF <sub>16</sub> is a reserved area.
Operating ambient temperature range		–20 to 85 °C
Device structure		CMOS high-performance silicon gate process
Package		100-pin plastic molded QFP

**Note:**

Flash memory (User ROM area)	M37902FCCHP	120 Kbytes
	M37902FGCHP	248 Kbytes
	M37902FJCHP	498 Kbytes
RAM	M37902FCCHP	4096 bytes
	M37902FGCHP	6144 bytes
	M37902FJCHP	12288 bytes

MITSUBISHI MICROCOMPUTERS

# M37902FCCHP, M37902FGCHP, M37902FJCHP

SINGLE-CHIP 16-BIT CMOS MICROCOMPUTER

## FUNCTIONS (Flash memory mode)

Parameter		Functions
Power supply voltage		5 V±0.5 V (in the flash memory parallel I/O mode, 3.3 V±0.3 V)
Programming/Erase voltage		5 V±0.5 V (in the flash memory parallel I/O mode, 3.3 V±0.3 V)
Flash memory mode		3 modes: parallel I/O, serial I/O, and CPU reprogramming modes
Block division for erasure	User ROM area	<b>(Note 1)</b>
	Boot ROM area	1 block (16 Kbytes × 1) <b>(Note 2)</b>
Programming method	Programmed per page (in a unit of 256 Kbytes)	
	Flash memory parallel I/O mode	User ROM area + Boot ROM area
	Flash memory serial I/O mode	User ROM area
	Flash memory CPU reprogramming mode	User ROM area
Erase method	Total erase/Block erase	
	Flash memory parallel I/O mode	User ROM area + Boot ROM area
	Flash memory serial I/O mode	User ROM area
	Flash memory CPU reprogramming mode	User ROM area
Programming/Erase control		Programming/Erase control by software commands
Data protection method		Protected per block, by using a lock bit.
Number of commands		8 commands
Maximum number of reprograms		100

**Notes 1:**

User ROM area	M37902FCCHP	5 blocks (8 Kbytes × 3, 32 Kbytes × 1, 64 Kbytes × 1), total 120 Kbytes
	M37902FGCHP	7 blocks (8 Kbytes × 3, 32 Kbytes × 1, 64 Kbytes × 3), total 248 Kbytes
	M37902FJCHP	11 blocks (2 Kbytes × 1, 8 Kbytes × 2, 32 Kbytes × 1, 64 Kbytes × 7), total 498 Kbytes

**2:** On shipment, our reprogramming control firmware for the flash memory serial I/O mode has been stored into the boot ROM area. Note that the boot ROM area can be erased/programmed only in the flash memory parallel I/O mode.

MITSUBISHI MICROCOMPUTERS

# M37902FCCHP, M37902FGCHP, M37902FJCHP

SINGLE-CHIP 16-BIT CMOS MICROCOMPUTER

## PIN DESCRIPTION (MICROCOMPUTER MODE)

Pin	Name	Input/ Output	Functions
Vcc, Vss	Power supply input	—	Apply 5 V±0.5 V to Vcc, and 0 V to Vss.
MD0	MD0	Input	This pin controls the processor mode. Connect this pin to Vss for the single-chip mode or memory expansion mode, and VCC for the microprocessor mode.
MD1	MD1	Input	Connect this pin to Vss.
$\overline{\text{RESET}}$	Reset input	Input	The microcomputer is reset when "L" level is applied to this pin.
XIN	Clock input	Input	These are input and output pins of the internal clock generating circuit. Connect a ceramic or quartz- crystal resonator between the XIN and XOUT pins. When an external clock is used, the clock source should be connected to the XIN pin, and the XOUT pin should be left open.
XOUT	Clock output	Output	
BYTE	External data bus width select input	Input	This pin determines whether the external data bus has an 8-bit width or 16-bit width for the memory expansion mode or microprocessor mode. The width is 16 bits when "L" signal is input, and 8 bits when "H" signal is input. When BYTE = Vss level, by the register setting, the external data bus for each of areas CS <sub>1</sub> to CS <sub>3</sub> can have a width of 8 bits.
VCONT	Filter circuit connection	—	When using the PLL frequency multiplier, connect this pin to the filter circuit. When not using, this pin should be left open.
AVcc, AVss	Analog power supply input	—	Power supply input pins for the A-D converter and the D-A converter. Connect AVcc to Vcc, and AVss to Vss externally.
VREF	Reference voltage input	Input	This is the reference voltage input pin for the A-D converter and the D-A converter.
P00–P07	I/O port P0	I/O	<ul style="list-style-type: none"> <li>■ In single-chip mode Port P0 is an 8-bit I/O port. This port has an I/O direction register, and each pin can be programmed for input or output. These pins enter the input mode at reset.</li> <li>■ In memory expansion and microprocessor modes Address (A<sub>16</sub>–A<sub>23</sub>) is output. These pins also function as I/O port pins according to the register setting.</li> </ul>
P10–P17	I/O port P1	I/O	<ul style="list-style-type: none"> <li>■ In single-chip mode These pins have the same functions as port P0.</li> <li>■ In memory expansion and microprocessor modes The low-order 8 bits of data (D<sub>0</sub>–D<sub>7</sub>) are input/output. When the external data bus has an 8-bit width, address (LA<sub>0</sub>–LA<sub>7</sub>) output and data (D<sub>0</sub>–D<sub>7</sub>) input/output can be performed with the time-sharing method, according to the register setting.</li> </ul>
P20–P27	I/O port P2	I/O	<ul style="list-style-type: none"> <li>■ In single-chip mode or When 8-bit external data bus is used in memory expansion mode and microprocessor mode These pins have the same functions as port P0.</li> <li>■ When the 16-bit external data bus is used in memory expansion or microprocessor mode The high-order 8 bits of data (D<sub>8</sub>–D<sub>15</sub>) are input or output.</li> </ul>
P30–P33	I/O port P3	I/O	<ul style="list-style-type: none"> <li>■ In single-chip mode These pins have the same functions as port P0.</li> <li>■ In memory expansion mode P30 functions as an I/O port pin; and P31, P32, and P33 function as the output pins of RD, BLW, BHW, respectively. P30 also functions as an output pin of RDY according to the register setting. When the external data bus has a width of 8 bits, the BHW pin functions as an I/O port pin (P33).</li> <li>■ In microprocessor mode P30 functions as an input pin of <math>\overline{\text{RDY}}</math>; and P31, P32, P33 function as the output pins of RD, BLW, BHW, respectively. P30 also functions as an I/O port pin according to the register setting. When the external data bus has a width of 8 bits, the BHW pin functions as an I/O port pin (P33).</li> </ul>
P40–P47	I/O port P4	I/O	<ul style="list-style-type: none"> <li>■ In single-chip mode These pins have the same functions as port P0.</li> <li>■ In memory expansion mode P40–P47 function as I/O port pins. According to the register setting, these pins function as output pins or input pins of ALE, <math>\phi_1</math>, HLDA, HOLD, CS<sub>0</sub>–CS<sub>3</sub>, respectively.</li> <li>■ In microprocessor mode P40–P44 function as output or input pins of ALE, <math>\phi_1</math>, <math>\overline{\text{HLDA}}</math>, <math>\overline{\text{HOLD}}</math>, <math>\overline{\text{CS}}_0</math>, and P45–P47 as I/O port pins, respectively. According to the register setting, P40–P43 also function as I/O port pins, and P45–P47 as output pins of CS<sub>1</sub>–CS<sub>3</sub>.</li> </ul>

MITSUBISHI MICROCOMPUTERS

# M37902FCCHP, M37902FGCHP, M37902FJCHP

SINGLE-CHIP 16-BIT CMOS MICROCOMPUTER

Pin	Name	Input/ Output	Functions
P50–P57	I/O port P5	I/O	In addition to having the same functions as port P0 in the single-chip mode, these pins also function as I/O pins for timers A0–A3, output pins for the real-time output, and input pins for the key-input interrupt.
P60–P67	I/O port P6	I/O	In addition to having the same functions as port P0 in the single-chip mode, these pins also function as I/O pins for timer A4, input pins for external interrupt inputs $\overline{\text{INT}}_0$ – $\overline{\text{INT}}_2$ , and input pins for timers B0–B2.
P70–P77	I/O port P7	I/O	In addition to having the same functions as port P0 in the single-chip mode, these pins also function as input pins for the A-D converter, output pins for the D-A converter, and input pins for $\overline{\text{INT}}_2$ , $\overline{\text{INT}}_3$ , and $\overline{\text{INT}}_4$ .
P80–P87	I/O port P8	I/O	In addition to having the same functions as port P0 in the single-chip mode, these pins also function as I/O pins for UART0, UART1, output pins for D-A converter, and input pins for $\overline{\text{INT}}_3$ and $\overline{\text{INT}}_4$ .
P100–P107	I/O port P10	I/O	<ul style="list-style-type: none"> <li>■ In single-chip mode These pins have the same functions as port P0.</li> <li>■ In memory expansion and microprocessor modes Address (A0–A7) is output.</li> </ul>
P110–P117	I/O port P11	I/O	<ul style="list-style-type: none"> <li>■ In single-chip mode These pins have the same functions as port P0.</li> <li>■ In memory expansion and microprocessor modes Address (A8–A15) is output. Also, these pins function as I/O port pins according to the register setting.</li> </ul>
$\overline{\text{NMI}}$	Non-maskable interrupt	Input	This pin is for a non-maskable interrupt.

MITSUBISHI MICROCOMPUTERS

# M37902FCCHP, M37902FGCHP, M37902FJCHP

SINGLE-CHIP 16-BIT CMOS MICROCOMPUTER

## PIN DESCRIPTION (FLASH MEMORY SERIAL I/O MODE)

Pin	Name	Input /Output	Functions
Vcc, Vss	Power supply input	—	Apply 5 V $\pm$ 0.5 V to Vcc, and 0 V to Vss.
MD0	MD0	Input	Connect this pin to Vss.
MD1	MD1	Input	Connect this pin to Vss via a resistor of 10 k $\Omega$ to 100 k $\Omega$ .
RESET	Reset input	Input	The reset input pin.
XIN	Clock input	Input	Connect a ceramic resonator between the XIN and XOUT pins, or input an external clock from the XIN pin with the XOUT pin left open.
XOUT	Clock output	Output	
BYTE	BYTE	Input	Connect this pin to Vcc or Vss. (This is not used in the flash memory serial I/O mode.)
VCONT	Filter circuit connection	—	Connect this pin to the filter circuit, or leave this pin open. (This is not used in the flash memory serial I/O mode.)
AVcc, AVss	Analog supply input	—	Connect AVcc to Vcc, and AVss to Vss.
VREF	Reference voltage input	Input	Input an arbitrary level within the range of Vss–Vcc. (This is not used in the flash memory serial I/O mode.)
P00–P07	Input port P0	Input	Input “H” or “L”, or leave them open. (This is not used in the flash memory serial I/O mode.)
P10–P17	Input port P1	Input	Input “H” or “L”, or leave them open. (This is not used in the flash memory serial I/O mode.)
P20–P27	Input port P2	Input	Input “H” or “L”, or leave them open. (This is not used in the flash memory serial I/O mode.)
P30–P33	Input port P3	Input	Input “H” or “L”, or leave them open. (This is not used in the flash memory serial I/O mode.)
P40, P44– P47	Input port P4	Input	Input “H” or “L”, or leave them open. (This is not used in the flash memory serial I/O mode.)
P41	SCLK input	Input	This is an input pin for a serial clock.
P42	SDA I/O	I/O	This is an I/O pin for serial data. Connect this pin to Vcc via a resistor (about 1 k $\Omega$ ).
P43	BUSY output	Output	This is an output pin for the BUSY signal.
P50–P57	Input port P5	Input	Input “H” or “L”, or leave them open. (This is not used in the flash memory serial I/O mode.)
P60–P67	Input port P6	Input	Input “H” or “L”, or leave them open. (This is not used in the flash memory serial I/O mode.)
P70–P77	Input port P7	Input	Input “H” or “L”, or leave them open. (This is not used in the flash memory serial I/O mode.)
P80–P87	Input port P8	Input	Input “H” or “L”, or leave them open. (This is not used in the flash memory serial I/O mode.)
P100–P107	Input port P10	Input	Input “H” or “L”, or leave them open. (This is not used in the flash memory serial I/O mode.)
P110–P117	Input port P11	Input	Input “H” or “L”, or leave them open. (This is not used in the flash memory serial I/O mode.)
NMI	Non-maskable interrupt	Input	Input “H”, or leave this pin open.



# MITSUBISHI MICROCOMPUTERS

## M37902FCCHP, M37902FGCHP, M37902FJCHP

SINGLE-CHIP 16-BIT CMOS MICROCOMPUTER

### BASIC FUNCTION BLOCKS

These microcomputers contain the following devices on the single chip: the flash memory, RAM, CPU, bus interface unit, and peripheral devices such as the interrupt control circuit, timers, serial I/O, A-D converter, D-A converter, I/O ports, clock generating circuit, etc.

### MEMORY

Figures 1 to 3 show the memory maps. The address space is 16 Mbytes from addresses 0<sub>16</sub> to FFFFFFF<sub>16</sub>. The address space is divided into 64-Kbyte units called banks. The banks are numbered from 0<sub>16</sub> to FF<sub>16</sub>. Bank FF<sub>16</sub> is a reserved area for the development support tool. Therefore, do not use bank FF<sub>16</sub>.

Internal flash memory and internal RAM are assigned as shown in Figures 1 to 3.

Addresses FFC0<sub>16</sub> to FFFF<sub>16</sub> contain the RESET and the interrupt vector addresses, and the interrupt vectors are stored there.

For details, refer to the section on interrupts.

Assigned to addresses 0<sub>16</sub> to FF<sub>16</sub> are peripheral devices such as I/O ports, A-D converter, D-A converter, UART, timers, interrupt control registers, etc. Figures 7 and 8 show the location of SFRs.

For the flash memory in the boot ROM area, refer to the section on the flash memory mode.

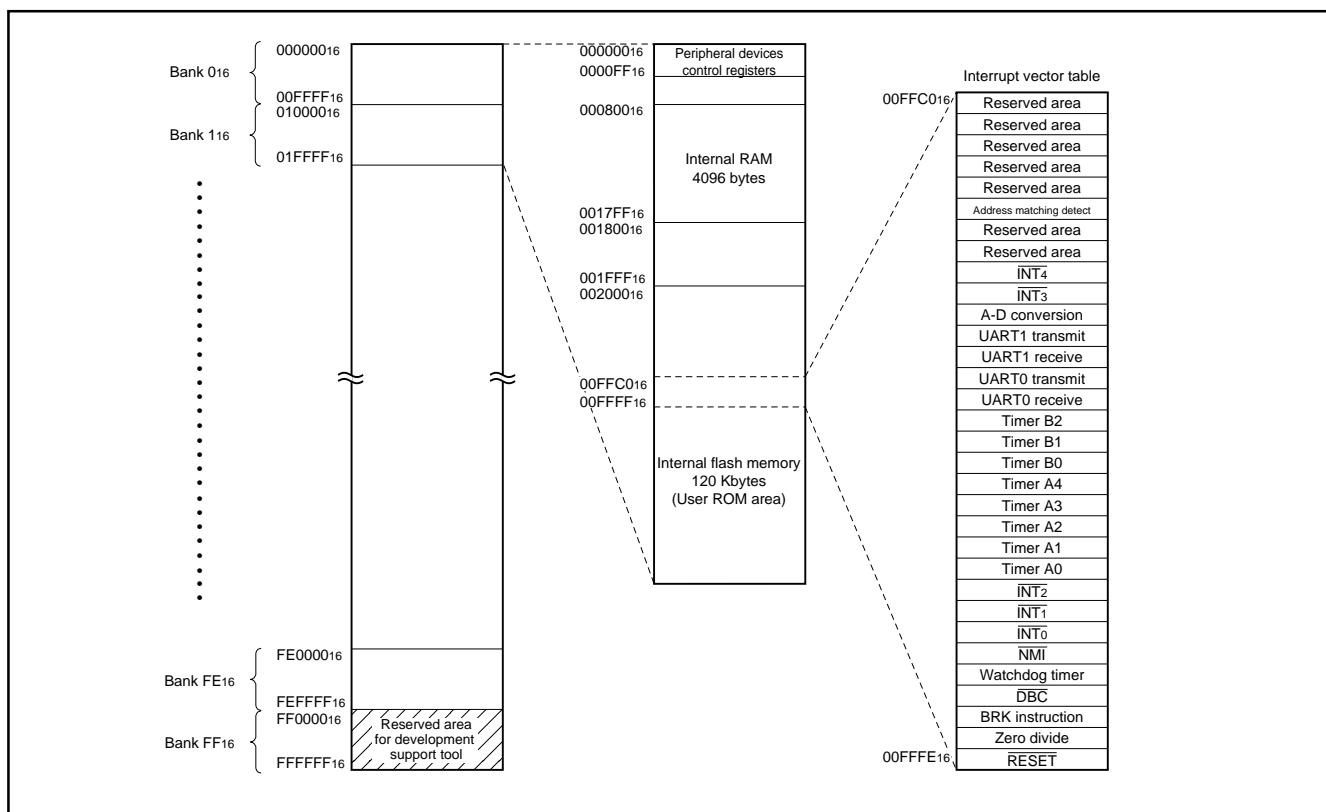

Fig. 1 Memory map of M37902FCCHP (Single-chip mode)

# MITSUBISHI MICROCOMPUTERS

## M37902FCCHP, M37902FGCHP, M37902FJCHP

SINGLE-CHIP 16-BIT CMOS MICROCOMPUTER

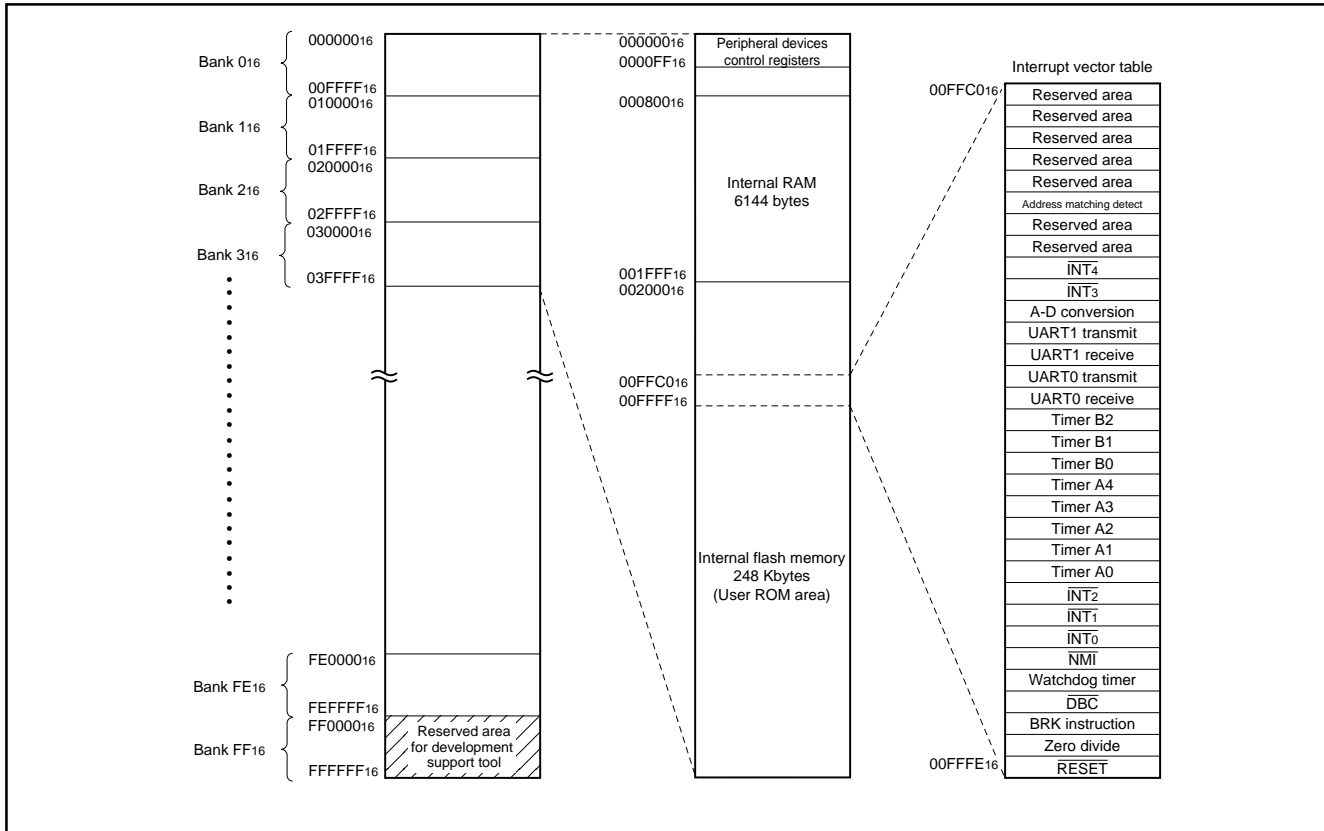

Fig. 2 Memory map of M37902FGCHP (Single-chip mode)

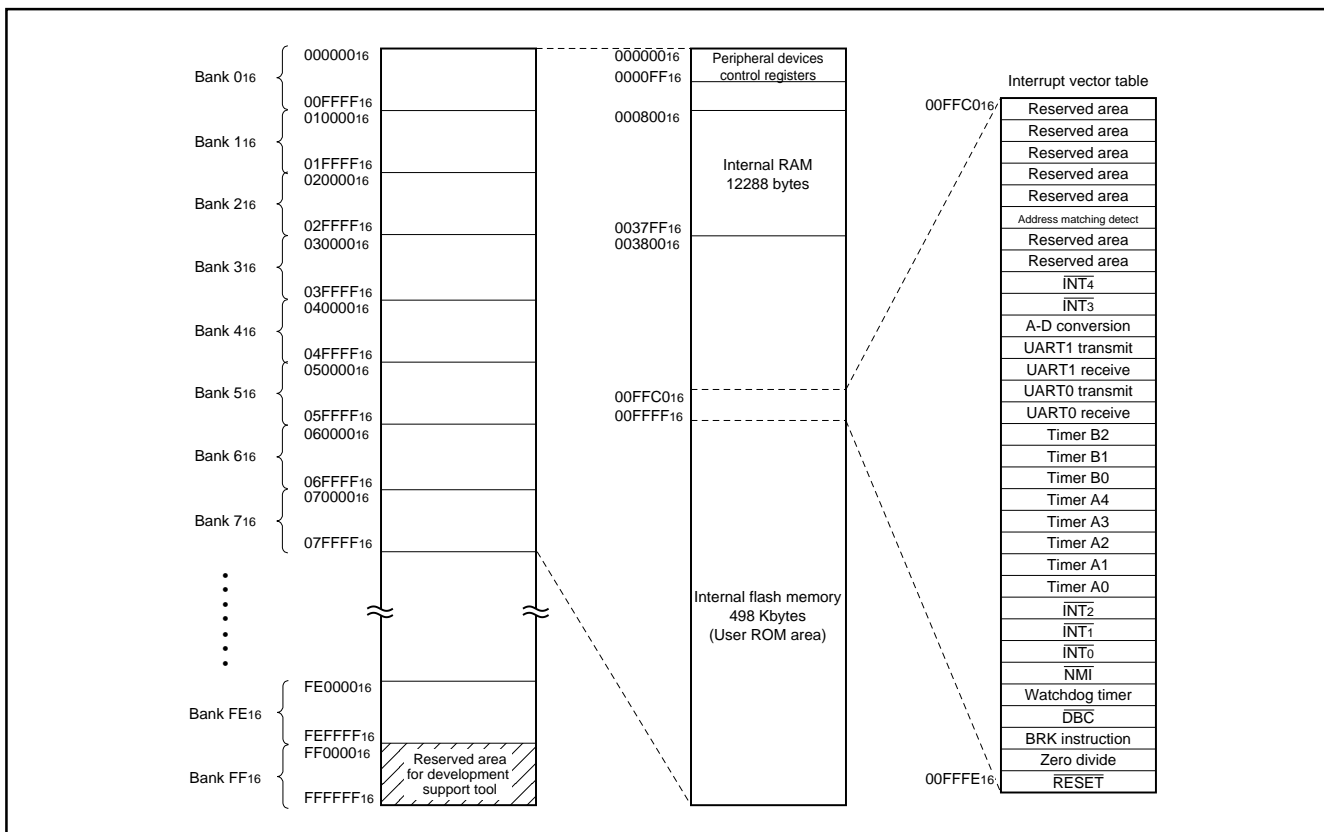

Fig. 3 Memory map of M37902FJCHP (Single-chip mode)

MITSUBISHI MICROCOMPUTERS

# M37902FCCHP, M37902FGCHP, M37902FJCHP

SINGLE-CHIP 16-BIT CMOS MICROCOMPUTER

Address (Hexadecimal notation)		Address (Hexadecimal notation)	
000000 <sup>16</sup>	Reserved area ( <b>Note</b> )	000040 <sup>16</sup>	Count start register
000001 <sup>16</sup>	Reserved area ( <b>Note</b> )	000041 <sup>16</sup>	
000002 <sup>16</sup>	Port P0 register	000042 <sup>16</sup>	One-shot start register
000003 <sup>16</sup>	Port P1 register	000043 <sup>16</sup>	
000004 <sup>16</sup>	Port P0 direction register	000044 <sup>16</sup>	Up-down register
000005 <sup>16</sup>	Port P1 direction register	000045 <sup>16</sup>	Timer A clock division select register
000006 <sup>16</sup>	Port P2 register	000046 <sup>16</sup>	Timer A0 register
000007 <sup>16</sup>	Port P3 register	000047 <sup>16</sup>	
000008 <sup>16</sup>	Port P2 direction register	000048 <sup>16</sup>	Timer A1 register
000009 <sup>16</sup>	Port P3 direction register	000049 <sup>16</sup>	
00000A <sup>16</sup>	Port P4 register	00004A <sup>16</sup>	Timer A2 register
00000B <sup>16</sup>	Port P5 register	00004B <sup>16</sup>	
00000C <sup>16</sup>	Port P4 direction register	00004C <sup>16</sup>	Timer A3 register
00000D <sup>16</sup>	Port P5 direction register	00004D <sup>16</sup>	
00000E <sup>16</sup>	Port P6 register	00004E <sup>16</sup>	Timer A4 register
00000F <sup>16</sup>	Port P7 register	00004F <sup>16</sup>	
000010 <sup>16</sup>	Port P6 direction register	000050 <sup>16</sup>	Timer B0 register
000011 <sup>16</sup>	Port P7 direction register	000051 <sup>16</sup>	
000012 <sup>16</sup>	Port P8 register	000052 <sup>16</sup>	Timer B1 register
000013 <sup>16</sup>		000053 <sup>16</sup>	
000014 <sup>16</sup>	Port P8 direction register	000054 <sup>16</sup>	Timer B2 register
000015 <sup>16</sup>		000055 <sup>16</sup>	
000016 <sup>16</sup>	Port P10 register	000056 <sup>16</sup>	Timer A0 mode register
000017 <sup>16</sup>	Port P11 register	000057 <sup>16</sup>	Timer A1 mode register
000018 <sup>16</sup>	Port P10 direction register	000058 <sup>16</sup>	Timer A2 mode register
000019 <sup>16</sup>	Port P11 direction register	000059 <sup>16</sup>	Timer A3 mode register
00001A <sup>16</sup>		00005A <sup>16</sup>	Timer A4 mode register
00001B <sup>16</sup>		00005B <sup>16</sup>	Timer B0 mode register
00001C <sup>16</sup>		00005C <sup>16</sup>	Timer B1 mode register
00001D <sup>16</sup>		00005D <sup>16</sup>	Timer B2 mode register
00001E <sup>16</sup>	A-D control register 0	00005E <sup>16</sup>	Processor mode register 0
00001F <sup>16</sup>	A-D control register 1	00005F <sup>16</sup>	Processor mode register 1
000020 <sup>16</sup>	A-D register 0	000060 <sup>16</sup>	Watchdog timer register
000021 <sup>16</sup>		000061 <sup>16</sup>	Watchdog timer frequency select register
000022 <sup>16</sup>	A-D register 1	000062 <sup>16</sup>	Particular function select register 0
000023 <sup>16</sup>		000063 <sup>16</sup>	Particular function select register 1
000024 <sup>16</sup>	A-D register 2	000064 <sup>16</sup>	Particular function select register 2
000025 <sup>16</sup>		000065 <sup>16</sup>	Reserved area ( <b>Note</b> )
000026 <sup>16</sup>	A-D register 3	000066 <sup>16</sup>	Debug control register 0
000027 <sup>16</sup>		000067 <sup>16</sup>	Debug control register 1
000028 <sup>16</sup>	A-D register 4	000068 <sup>16</sup>	
000029 <sup>16</sup>		000069 <sup>16</sup>	Address comparison register 0
00002A <sup>16</sup>	A-D register 5	00006A <sup>16</sup>	
00002B <sup>16</sup>		00006B <sup>16</sup>	
00002C <sup>16</sup>	A-D register 6	00006C <sup>16</sup>	Address comparison register 1
00002D <sup>16</sup>		00006D <sup>16</sup>	
00002E <sup>16</sup>	A-D register 7	00006E <sup>16</sup>	INT3 interrupt control register
00002F <sup>16</sup>		00006F <sup>16</sup>	INT4 interrupt control register
000030 <sup>16</sup>	UART0 transmit/receive mode register	000070 <sup>16</sup>	A-D conversion interrupt control register
000031 <sup>16</sup>	UART0 baud rate register (BRG0)	000071 <sup>16</sup>	UART0 transmit interrupt control register
000032 <sup>16</sup>	UART0 transmit buffer register	000072 <sup>16</sup>	UART0 receive interrupt control register
000033 <sup>16</sup>		000073 <sup>16</sup>	UART1 transmit interrupt control register
000034 <sup>16</sup>	UART0 transmit/receive control register 0	000074 <sup>16</sup>	UART1 receive interrupt control register
000035 <sup>16</sup>	UART0 transmit/receive control register 1	000075 <sup>16</sup>	Timer A0 interrupt control register
000036 <sup>16</sup>	UART0 receive buffer register	000076 <sup>16</sup>	Timer A1 interrupt control register
000037 <sup>16</sup>		000077 <sup>16</sup>	Timer A2 interrupt control register
000038 <sup>16</sup>	UART1 transmit/receive mode register	000078 <sup>16</sup>	Timer A3 interrupt control register
000039 <sup>16</sup>	UART1 baud rate register (BRG1)	000079 <sup>16</sup>	Timer A4 interrupt control register
00003A <sup>16</sup>	UART1 transmit buffer register	00007A <sup>16</sup>	Timer B0 interrupt control register
00003B <sup>16</sup>		00007B <sup>16</sup>	Timer B1 interrupt control register
00003C <sup>16</sup>	UART1 transmit/receive control register 0	00007C <sup>16</sup>	Timer B2 interrupt control register
00003D <sup>16</sup>	UART1 transmit/receive control register 1	00007D <sup>16</sup>	INT0 interrupt control register
00003E <sup>16</sup>	UART1 receive buffer register	00007E <sup>16</sup>	INT1 interrupt control register
00003F <sup>16</sup>		00007F <sup>16</sup>	INT2 interrupt control register

**Note:** Do not write to this address.

Fig. 7 Location of SFRs (1)

MITSUBISHI MICROCOMPUTERS

# M37902FCCHP, M37902FGCHP, M37902FJCHP

SINGLE-CHIP 16-BIT CMOS MICROCOMPUTER

Address (Hexadecimal notation)	Address (Hexadecimal notation)		
000080 <sub>16</sub>	CS <sub>0</sub> control register L	0000C0 <sub>16</sub>	
000081 <sub>16</sub>	CS <sub>0</sub> control register H	0000C1 <sub>16</sub>	
000082 <sub>16</sub>	CS <sub>1</sub> control register L	0000C2 <sub>16</sub>	
000083 <sub>16</sub>	CS <sub>1</sub> control register H	0000C3 <sub>16</sub>	
000084 <sub>16</sub>	CS <sub>2</sub> control register L	0000C4 <sub>16</sub>	
000085 <sub>16</sub>	CS <sub>2</sub> control register H	0000C5 <sub>16</sub>	
000086 <sub>16</sub>	CS <sub>3</sub> control register L	0000C6 <sub>16</sub>	
000087 <sub>16</sub>	CS <sub>3</sub> control register H	0000C7 <sub>16</sub>	
000088 <sub>16</sub>		0000C8 <sub>16</sub>	
000089 <sub>16</sub>		0000C9 <sub>16</sub>	
00008A <sub>16</sub>	Area CS <sub>0</sub> start address register	0000CA <sub>16</sub>	
00008B <sub>16</sub>		0000CB <sub>16</sub>	
00008C <sub>16</sub>	Area CS <sub>1</sub> start address register	0000CC <sub>16</sub>	
00008D <sub>16</sub>		0000CD <sub>16</sub>	
00008E <sub>16</sub>	Area CS <sub>2</sub> start address register	0000CE <sub>16</sub>	
00008F <sub>16</sub>		0000CF <sub>16</sub>	
000090 <sub>16</sub>	Area CS <sub>3</sub> start address register	0000D0 <sub>16</sub>	
000091 <sub>16</sub>		0000D1 <sub>16</sub>	
000092 <sub>16</sub>	Port function control register	0000D2 <sub>16</sub>	
000093 <sub>16</sub>		0000D3 <sub>16</sub>	
000094 <sub>16</sub>	External interrupt input control register	0000D4 <sub>16</sub>	
000095 <sub>16</sub>	External interrupt input read-out register	0000D5 <sub>16</sub>	
000096 <sub>16</sub>	D-A control register	0000D6 <sub>16</sub>	
000097 <sub>16</sub>		0000D7 <sub>16</sub>	
000098 <sub>16</sub>	D-A register 0	0000D8 <sub>16</sub>	
000099 <sub>16</sub>	D-A register 1	0000D9 <sub>16</sub>	
00009A <sub>16</sub>	D-A register 2	0000DA <sub>16</sub>	
00009B <sub>16</sub>		0000DB <sub>16</sub>	
00009C <sub>16</sub>	Reserved area (Note)	0000DC <sub>16</sub>	
00009D <sub>16</sub>	Reserved area (Note)	0000DD <sub>16</sub>	
00009E <sub>16</sub>	Flash memory control register	0000DE <sub>16</sub>	
00009F <sub>16</sub>		0000DF <sub>16</sub>	
0000A0 <sub>16</sub>	Real-time output control register	0000E0 <sub>16</sub>	
0000A1 <sub>16</sub>		0000E1 <sub>16</sub>	
0000A2 <sub>16</sub>	Pulse output data register 0	0000E2 <sub>16</sub>	
0000A3 <sub>16</sub>		0000E3 <sub>16</sub>	
0000A4 <sub>16</sub>	Pulse output data register 1	0000E4 <sub>16</sub>	
0000A5 <sub>16</sub>		0000E5 <sub>16</sub>	
0000A6 <sub>16</sub>		0000E6 <sub>16</sub>	
0000A7 <sub>16</sub>		0000E7 <sub>16</sub>	
0000A8 <sub>16</sub>		0000E8 <sub>16</sub>	
0000A9 <sub>16</sub>		0000E9 <sub>16</sub>	
0000AA <sub>16</sub>		0000EA <sub>16</sub>	
0000AB <sub>16</sub>		0000EB <sub>16</sub>	
0000AC <sub>16</sub>	Serial I/O pin control register	0000EC <sub>16</sub>	
0000AD <sub>16</sub>		0000ED <sub>16</sub>	
0000AE <sub>16</sub>		0000EE <sub>16</sub>	
0000AF <sub>16</sub>		0000EF <sub>16</sub>	
0000B0 <sub>16</sub>		0000F0 <sub>16</sub>	
0000B1 <sub>16</sub>		0000F1 <sub>16</sub>	
0000B2 <sub>16</sub>		0000F2 <sub>16</sub>	
0000B3 <sub>16</sub>		0000F3 <sub>16</sub>	
0000B4 <sub>16</sub>		0000F4 <sub>16</sub>	
0000B5 <sub>16</sub>		0000F5 <sub>16</sub>	
0000B6 <sub>16</sub>		0000F6 <sub>16</sub>	
0000B7 <sub>16</sub>		0000F7 <sub>16</sub>	
0000B8 <sub>16</sub>		0000F8 <sub>16</sub>	
0000B9 <sub>16</sub>		0000F9 <sub>16</sub>	
0000BA <sub>16</sub>	Reserved area (Note)	0000FA <sub>16</sub>	
0000BB <sub>16</sub>	Reserved area (Note)	0000FB <sub>16</sub>	
0000BC <sub>16</sub>	Clock control register	0000FC <sub>16</sub>	
0000BD <sub>16</sub>	Reserved area (Note)	0000FD <sub>16</sub>	
0000BE <sub>16</sub>	Reserved area (Note)	0000FE <sub>16</sub>	
0000BF <sub>16</sub>	Reserved area (Note)	0000FF <sub>16</sub>	

**Note:** Do not write to this address.

Fig. 8 Location of SFRs (2)

# MITSUBISHI MICROCOMPUTERS

## M37902FCCHP, M37902FGCHP, M37902FJCHP

SHINGLE-CHIP 16-BIT CMOS MICROCOMPUTER

### CENTRAL PROCESSING UNIT (CPU)

The CPU has 13 registers and is shown in Figure 9. Each of these registers is described below.

#### ACCUMULATOR A (A)

Accumulator A is the main register of the microcomputer. It consists of 16 bits and the low-order 8 bits can be used separately. Data length flag m determines whether the register is used as 16-bit register or as 8-bit register. It is used as a 16-bit register when flag m is "0" and as an 8-bit register when flag m is "1". Flag m is a part of the processor status register (PS) which is described later. Data operations such as calculations, data transfer, input/output, etc., are executed mainly through accumulator A.

#### ACCUMULATOR B (B)

Accumulator B has the same functions as accumulator A, but the use of accumulator B requires more instruction bytes and execution cycles than accumulator A.

#### ACCUMULATOR E

Accumulator E is a 32-bit register and consists of accumulator A (low-order 16 bits) and accumulator B (high-order 16 bits). It is used for 32-bit data processing.

#### INDEX REGISTER X (X)

Index register X consists of 16 bits and the low-order 8 bits can be used separately. Index register length flag x determines whether the register is used as 16-bit register or as 8-bit register. It is used as a 16-bit register when flag x is "0" and as an 8-bit register when flag x is "1". Flag x is a part of the processor status register (PS) which is described later.

In index addressing modes in which register X is used as the index register, the contents of this address are added to obtain the real address.

Index register X functions as a pointer register which indicates an address of data table in instructions MVP, MVN, RMPA (Repeat MultiPLY and Accumulate).

#### INDEX REGISTER Y (Y)

Index register Y consists of 16 bits and the low-order 8 bits can be used separately. The index register length flag x determines whether the register is used as 16-bit register or as 8-bit register. It is used as a 16-bit register when flag x is "0" and as an 8-bit register when flag x is "1". Flag x is a part of the processor status register (PS) which is described later.

In index addressing modes in which register Y is used as the index register, the contents of this address are added to obtain the real address.

Index register Y functions as a pointer register which indicates an address of data table in instructions MVP, MVN, RMPA (Repeat MultiPLY and Accumulate).

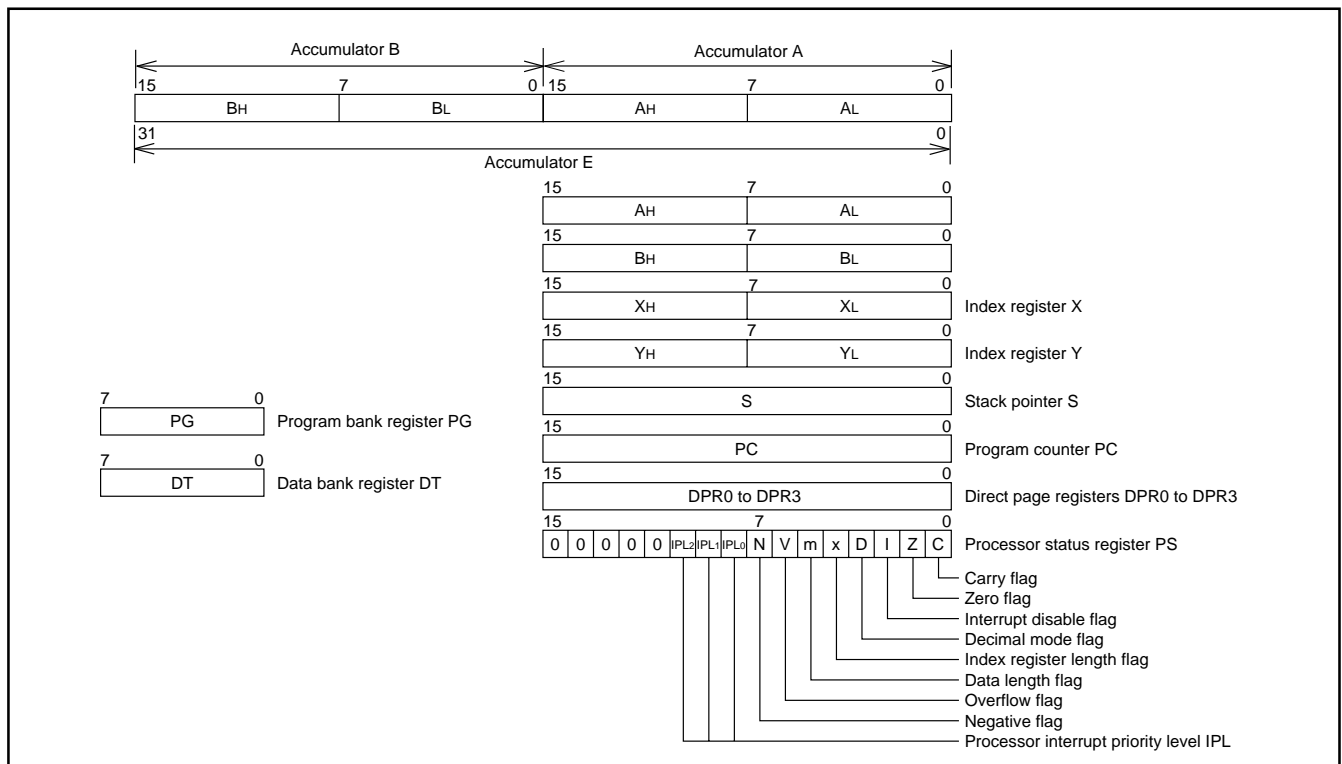

Fig. 9 Register structure

MITSUBISHI MICROCOMPUTERS

# M37902FCCHP, M37902FGCHP, M37902FJCHP

SHINGLE-CHIP 16-BIT CMOS MICROCOMPUTER

---

## STACK POINTER (S)

Stack pointer (S) is a 16-bit register. It is used during a subroutine call or interrupts. It is also used during stack, stack pointer relative, or stack pointer relative indirect indexed Y addressing mode.

## PROGRAM COUNTER (PC)

Program counter (PC) is a 16-bit counter that indicates the low-order 16 bits of the next program memory address to be executed. There is a bus interface unit between the program memory and the CPU, so that the program memory is accessed through bus interface unit. This is described later.

## PROGRAM BANK REGISTER (PG)

Program bank register is an 8-bit register that indicates the high-order 8 bits of the next program memory address to be executed. When a carry occurs by incrementing the contents of the program counter, the contents of the program bank register (PG) is increased by 1. Also, when a carry or borrow occurs after adding or subtracting the offset value to or from the contents of the program counter (PC) using the branch instruction, the contents of the program bank register (PG) is increased or decreased by 1, so that programs can be written without worrying about bank boundaries.

## DATA BANK REGISTER (DT)

Data bank register (DT) is an 8-bit register. With some addressing modes, the data bank register (DT) is used to specify a part of the memory address. The contents of data bank register (DT) is used as the high-order 8 bits of a 24-bit address. Addressing modes that use the data bank register (DT) are direct indirect, direct indexed X indirect, direct indirect indexed Y, absolute, absolute bit, absolute indexed X, absolute indexed Y, absolute bit relative, and stack pointer relative indirect indexed Y.

## DIRECT PAGE REGISTERS 0 to 3 (DPR0 to DPR3)

The direct page register is a 16-bit register. An addressing mode of which name includes 'direct' generates an address of data to be accessed, regarding the contents of this register as the base address. The 7900 Series has been expanded direct page registers up to 4 (DPR0 to DPR3), in comparison to the 7700 Series which has the single direct page register. Accordingly, the 7900 Series's direct addressing method which uses direct page registers differs from that of the 7700 Series. However, the conventional direct addressing method, using only DPR0, is still be selectable, in order to make use of the 7700 Series software property. For more details, refer to the section on the direct page.

## PROCESSOR STATUS REGISTER (PS)

Processor status register (PS) is an 11-bit register. It consists of flags to indicate the result of operation and CPU interrupt levels. Branch operations can be performed by testing the flags C, Z, V, and N.

The details of each bit of the processor status register are described below.

### 1. Carry flag (C)

The carry flag contains the carry or borrow generated by the ALU after an arithmetic operation. This flag is also affected by shift and rotate instructions. This flag can be set and reset directly with the SEC and CLC instructions or with the SEP and CLP instructions.

### 2. Zero flag (Z)

The zero flag is set if the result of an arithmetic operation or data transfer is zero and reset if it is not. This flag can be set and reset directly with the SEP and CLP instructions.

### 3. Interrupt disable flag (I)

When the interrupt disable flag is set to "1", all interrupts except watchdog timer, NMI, and software interrupt are disabled. This flag is set to "1" automatically when an interrupt is accepted. It can be set and reset directly with the SEI and CLI instructions or SEP and CLP instructions.

### 4. Decimal mode flag (D)

The decimal mode flag determines whether addition and subtraction are performed as binary or decimal. Binary arithmetic is performed when this flag is "0". If it is "1", decimal arithmetic is performed with each word treated as 2- or 4- digit decimal. Arithmetic operation is performed using four digits when data length flag m is "0" and with two digits when it is "1". Decimal adjust is automatically performed. (Decimal operation is possible only with the ADC and SBC instructions.) This flag can be set and reset with the SEP and CLP instructions.

MITSUBISHI MICROCOMPUTERS

# M37902FCCHP, M37902FGCHP, M37902FJCHP

SHINGLE-CHIP 16-BIT CMOS MICROCOMPUTER

---

## 5. Index register length flag (x)

The index register length flag determines whether index register X and index register Y are used as 16-bit registers or as 8-bit registers. The registers are used as 16-bit registers when flag x is "0" and as 8-bit registers when it is "1".

This flag can be set and reset with the SEP and CLP instructions.

## 6. Data length flag (m)

The data length flag determines whether the data length is 16-bit or 8-bit. The data length is 16 bits when flag m is "0" and 8 bits when it is "1". This flag can be set and reset with the SEM and CLM instructions or with the SEP and CLP instructions.

## 7. Overflow flag (V)

The overflow flag is valid when addition or subtraction is performed with a word treated as a signed binary number. If data length flag m is "0", the overflow flag is set when the result of addition or subtraction is outside the range between -32768 and +32767. If data length flag m is "1", the overflow flag is set when the result of addition or subtraction is outside the range between -128 and +127. It is reset in all other cases. The overflow flag can also be set and reset directly with the SEP, and CLV or CLP instructions.

Additionally, the overflow flag is set when a result of unsigned/signed division exceeds the length of the register where the result is to be stored; the flag is also set when the addition result is outside range of -2147483648 to +2147483647 in the RMPA operation.

## 8. Negative flag (N)

The negative flag is set when the result of arithmetic operation or data transfer is negative (If data length flag m is "0", data's bit 15 is "1". If data length flag m is "1", data's bit 7 is "1".) It is reset in all other cases. It can also be set and reset with the SEP and CLP instructions.

## 9. Processor interrupt priority level (IPL)

The processor interrupt priority level (IPL) consists of 3 bits and determines the priority of processor interrupts from level 0 to level 7. Interrupt is enabled when the interrupt priority of the device requesting interrupt (set using the interrupt control register) is higher than the processor interrupt priority. When an interrupt is enabled, the current processor interrupt priority level is saved in a stack and the processor interrupt priority level is replaced by the interrupt priority level of the device requesting the interrupt. Refer to the section on interrupts for more details.

**Note:** Fix bits 11 to 15 of the processor status register (PS) to "0".

---

MITSUBISHI MICROCOMPUTERS

# M37902FCCHP, M37902FGCHP, M37902FJCHP

SHINGLE-CHIP 16-BIT CMOS MICROCOMPUTER

---

## BANK

In order to effectively use the integrated hardware on the chip, this CPU core uses an address generating method with a 24-bit address split into high-order 8 bits and low-order 16 bits. In other words, the 64 Kbytes specified by the low-order 16 bits are one unit (referred to as "bank"), and the address space is divided into 256 banks (0<sub>16</sub> to FF<sub>16</sub>) specified by the high-order 8 bits.

In the program area on the address space, the bank is specified by the program bank register (PG), and the address in the bank is specified by the program counter (PC).

As for each bank boundary, when an overflow has occurred in PC, the contents of PG are incremented by 1. When a borrow has occurred in PC, the contents of PG are decremented by 1. Under the normal conditions, therefore, programming without concern for the bank boundaries is possible. Furthermore, as for the data area on the address space, the bank is specified by the data bank register (DT), and the address in the bank is specified by the operation result by using the various addressing modes (**Note**).

**Note:** Some addressing modes directly specify a bank.

## DIRECT PAGE

The internal memory and control registers for internal peripheral devices, etc. are assigned to bank 0<sub>16</sub> (addresses 0<sub>16</sub> to FFFF<sub>16</sub>). The direct page and direct addressing modes have been provided for the effective access to bank 0<sub>16</sub>. In the 7900 Series, two types of direct addressing modes are available: the conventional direct addressing mode which uses only DPR0, as in the 7700 Series, and the expanded direct addressing mode, which uses up to 4 direct page registers as selected by the user. The addressing mode is selected according to the contents of bit 1 of the processor mode register 1. This bit 1 is cleared to "0" at reset. (In other words, the conventional direct addressing mode is selected.) However, once this bit 1 has been set to "1" by software, this bit cannot be cleared to "0" again, except by reset. That is to say, when one of these two direct addressing modes has been selected just after reset, the selected addressing mode cannot be switched to another one while the program is running.

### ■ Conventional direct addressing mode

The direct page area consists of 256-byte space. Its bank address is "00<sub>16</sub>", and the base address of its low-order 16-bit address is specified by the contents of the direct page register 0 (DPR0). In this conventional direct addressing modes, a value (1 byte) just after an instruction code is regarded as an offset value for the DPR0 contents, and the CPU accesses each address in the direct page area.

### ■ Expanded direct addressing mode

The direct page area consists of four 64-byte spaces. Their bank address is "00<sub>16</sub>", and the four base addresses of their low-order 16-bit addresses are respectively specified by the contents of four direct page registers. In this expanded direct addressing mode, a value (1 byte) just after an instruction code is regarded as follows:

- High-order 2 bits: regarded as a selection field for DPR0 to DPR3.
- Low-order 6 bits: regarded as an offset value for the selected direct page register.

Then, the CPU accesses each address in each direct page area:

---

Refer to "7900 Series Software Manual" for details concerning the various addressing modes which use the direct page area.

## Instruction Set

The CPU core of the 7900 Series has an expanded instruction set based on the existing 7700/7751 Series' CPU core. In addition, its source code (mnemonic) has the complete upper compatibility with the 7700 Series instruction set.

For details concerning addressing modes and instruction set, refer to "7900 Series Software Manual".



MITSUBISHI MICROCOMPUTERS

# M37902FCCHP, M37902FGCHP, M37902FJCHP

SHINGLE-CHIP 16-BIT CMOS MICROCOMPUTER

## BUS INTERFACE UNIT

Data transfer between the central processing unit (CPU) and internal memory, internal peripheral devices, or external areas is always performed via the bus interface unit (BIU), which is located between the CPU and the internal buses.

Figure 10 shows the BIU and the bus structure. The CPU and BIU are connected by a dedicated bus, and any transfer between the CPU and BIU is controlled by this dedicated bus.

On the other hand, data transfer between the BIU and internal peripheral devices uses the following internal common buses: 32-bit code bus, 16-bit data bus, 24-bit address bus, and control signals.

The bus control method where the code bus and the data bus separate out (hereafter, this method is referred to as the separate code/

data bus method) is employed in order to improve data transfer capabilities. As a result, the internal memory is connected to both the code bus and the data bus, and registers of all other internal peripheral devices are connected only to the data bus.

Each width of external buses are as follows: a 24-bit address bus, 16-bit data bus.

The external data bus transfers instruction codes and data. When the code or data access occurs for the external, the external access is performed via the bus conversion circuit.

For details of the connection with the external devices, refer to the section on the processor modes and chip select wait controller described later.

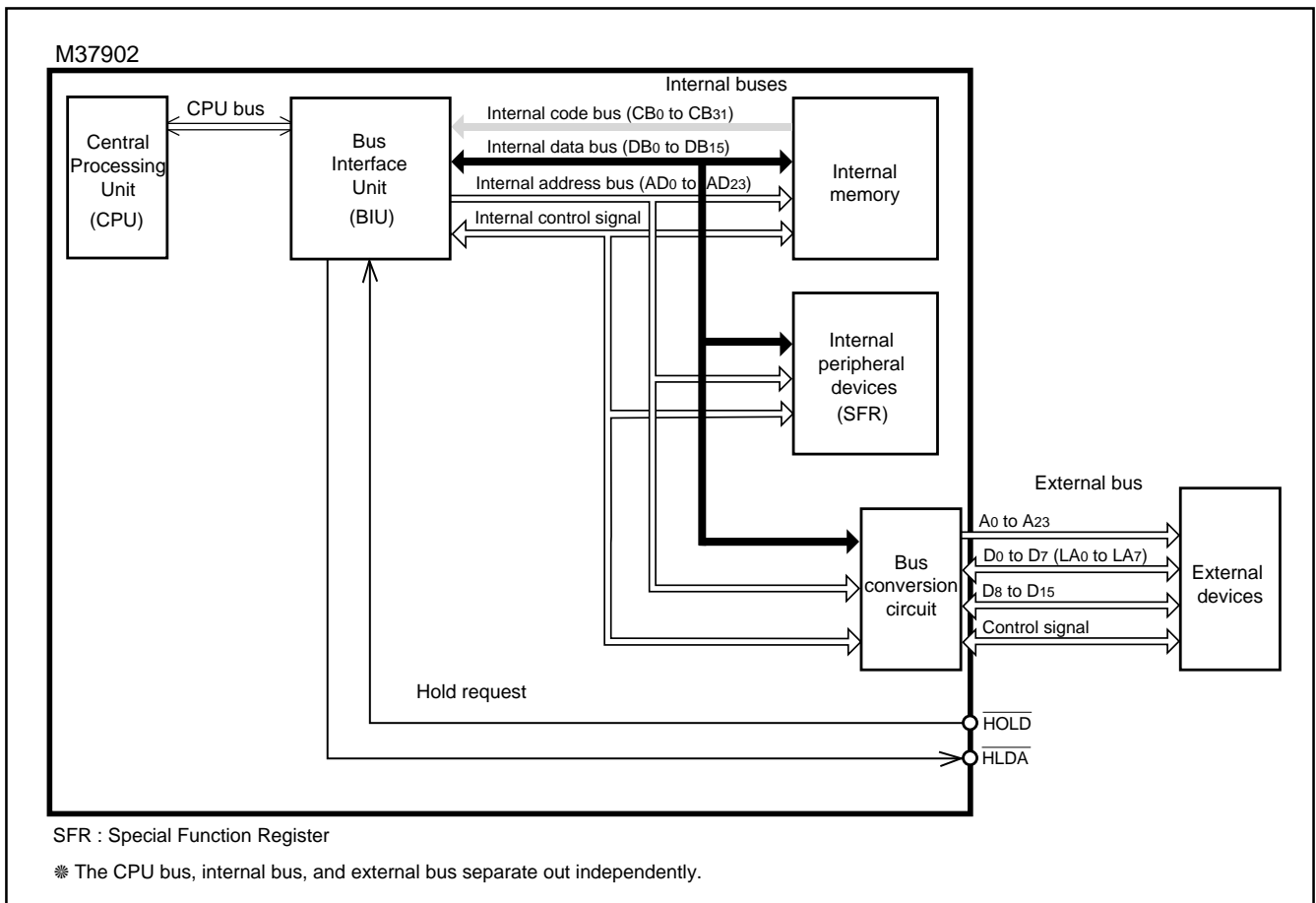

Fig. 10 BIU and bus structure

MITSUBISHI MICROCOMPUTERS

# M37902FCCHP, M37902FGCHP, M37902FJCHP

SHINGLE-CHIP 16-BIT CMOS MICROCOMPUTER

## BIU structure

The BIU consists of four registers shown in Figure 11. Table 1 lists the functions of each register.

Table 1. Functions of each register

Name	Functions
Program address register	Indicates a storage address for an instruction to be next taken into an instruction queue buffer.
Instruction queue buffer	Temporarily stores an instruction which has been taken from a memory. Consists of 10 bytes.
Data address register	Indicates an address where data will be next read from or written to.
Data buffer	Temporarily stores data which has been read from internal memory, internal peripheral devices, and external areas by the BIU; or temporarily stores data which is to be written to internal memory, internal peripheral devices, and external areas by the CPU. Consists of 32 bits.

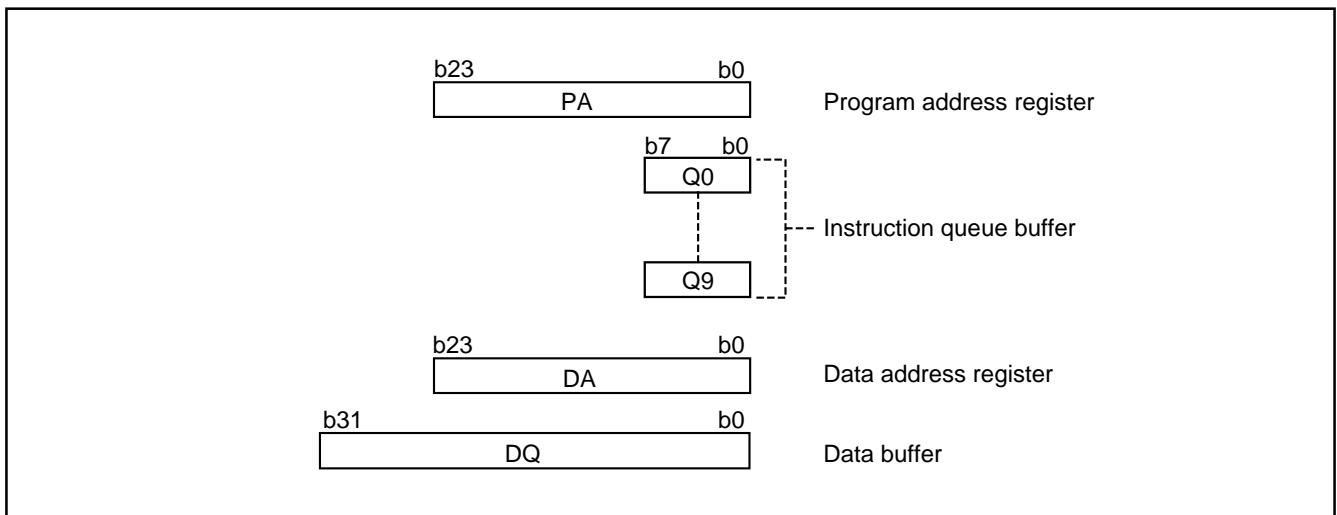

Fig.11 Register structure of BIU

# MITSUBISHI MICROCOMPUTERS

## M37902FCCHP, M37902FGCHP, M37902FJCHP

SHINGLE-CHIP 16-BIT CMOS MICROCOMPUTER

### BIU Functions

#### (1) Instruction prefetch

The BIU has ten instruction queue buffers; each buffer consists of 1 byte. When there is an opening in the bus and the instruction queue buffer, an instruction code is read from the program memory (in other words, the memory where a program is stored) and prefetched into an instruction queue buffer. The prefetched instruction code is transferred from the BIU to the CPU, in response to a request from the CPU, via a dedicated bus.

When a branch occurs as a result of a branch instruction (JMP, BRA, etc.), subroutine call, or interrupt, the contents of the instruction queue buffer are initialized and the BIU reads a new instruction from the branch destination address.

Note that the operations of the BIU instruction prefetch also differ depending on the store addresses for instructions. The store addresses for instructions to be prefetched are categorized as listed in Table 2.

#### (2) Data read operation

When executing an instruction for reading data from the internal memory, internal peripheral devices, or external areas, at first, the CPU informs the BIU's data address register of the address where the data has been located.

Next, the BIU reads the above data from the specified address, passes it to the data buffer, and then, transfers it to the CPU.

#### (3) Data write operation

When executing an instruction for writing data into the internal memory, internal peripheral devices, or external area, at first, the CPU informs the BIU's data address register of the address where the data has been located.

Next, the BIU passes the above data to the data buffer register, and then, writes it into the specified address.

#### (4) Bus cycle

In order for the BIU to execute the above operations (1) through (3), the 24-bit address bus, 32-bit code bus, 16-bit data bus and internal control signals must be appropriately controlled during data transfer between the BIU and internal memory, internal peripheral devices, external areas. This operation is called "bus cycle". The bus cycle is affected by the following conditions at instruction prefetch and data access.

#### [Instruction prefetch]

- Whether the address area locates in the internal area or the external area.
- When the address area locates in the external area
  - ① Whether the external bus width = 16 bits or 8 bits:
    - (a) When the external bus width = 16 bits: whether the start address for access locates at a 4-byte boundary or at an 8-byte boundary.
    - (b) When the external bus width = 8 bits: whether the start address for access locates at an even address, a 4-byte boundary or at the 8-byte boundary.
  - ② Whether the prefetch operation is generated by a branch, or not.
  - ③ Number of waits
  - ④ Whether the burst ROM access is specified or not.

Table 2. Store addresses for instructions to be prefetched

	Low-order 3 bits of store address for instruction		
	AD <sub>2</sub> (A <sub>2</sub> )	AD <sub>1</sub> (A <sub>1</sub> )	AD <sub>0</sub> (A <sub>0</sub> )
Even address	X	X	0
4-byte boundary	X	0	0
8-byte boundary	0	0	0

X: 0 or 1

#### [Data Access]

- Whether the address area locates in the internal area or the external area.
- Length of data to be transferred: byte, word, double word
- When the address area locates in the external area:
  - ① Whether the external bus width = 16 bits or 8 bits:
  - ② Number of waits

The BIU controls the bus cycle depending on the above conditions. Figures 12 to 16 show the bus cycle waveform examples for instruction prefetch and data access.

MITSUBISHI MICROCOMPUTERS  
**M37902FCCHP, M37902FGCHP, M37902FJCHP**

SHINGLE-CHIP 16-BIT CMOS MICROCOMPUTER

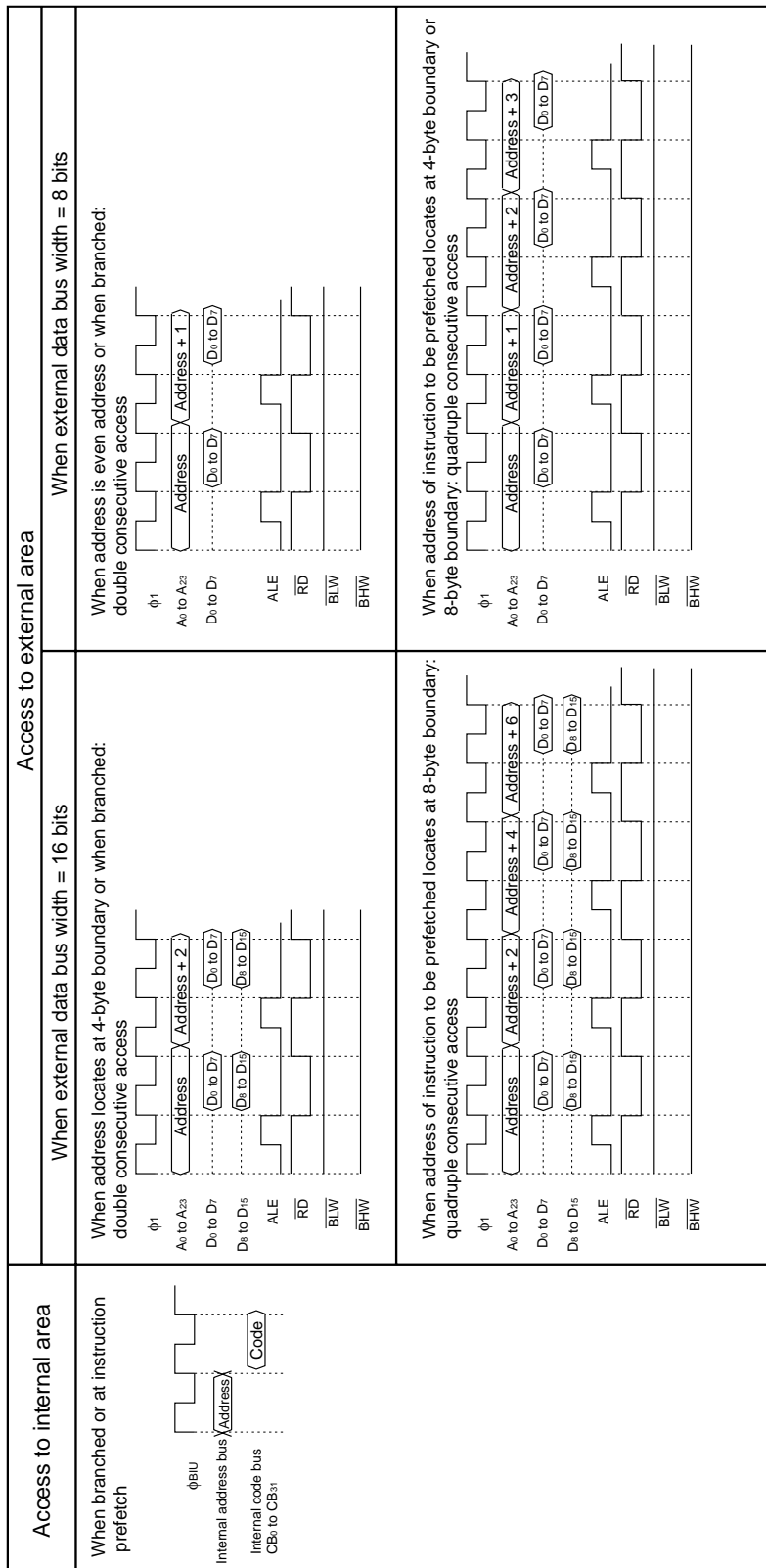

Fig. 12 Bus cycle waveform example for instruction prefetch

**MITSUBISHI MICROCOMPUTERS**  
**M37902FCCHP, M37902FGCHP, M37902FJCHP**

SHINGLE-CHIP 16-BIT CMOS MICROCOMPUTER

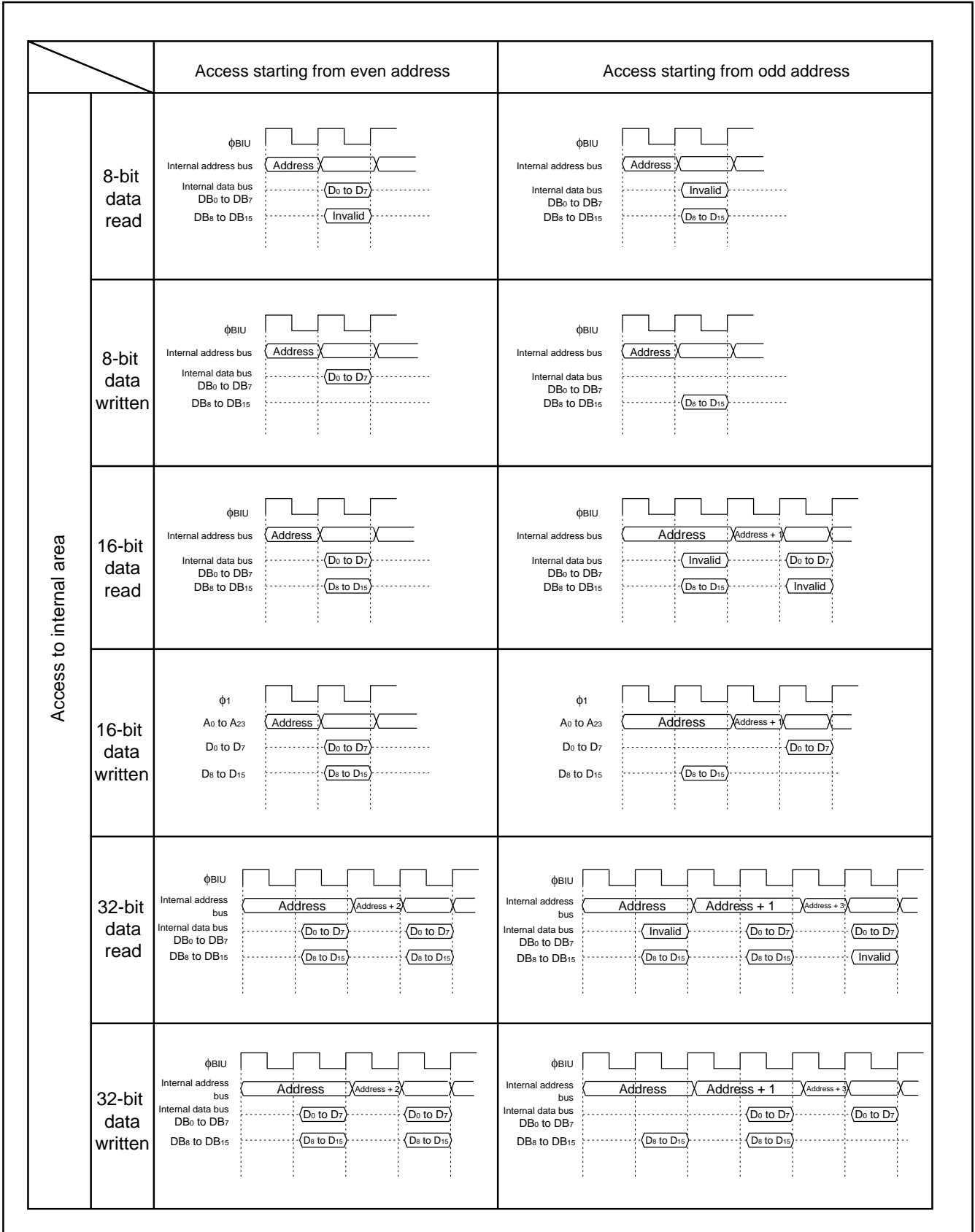

Fig. 13 Bus cycle waveform example for data access (access to internal area)

MITSUBISHI MICROCOMPUTERS

# M37902FCCHP, M37902FGCHP, M37902FJCHP

SHINGLE-CHIP 16-BIT CMOS MICROCOMPUTER

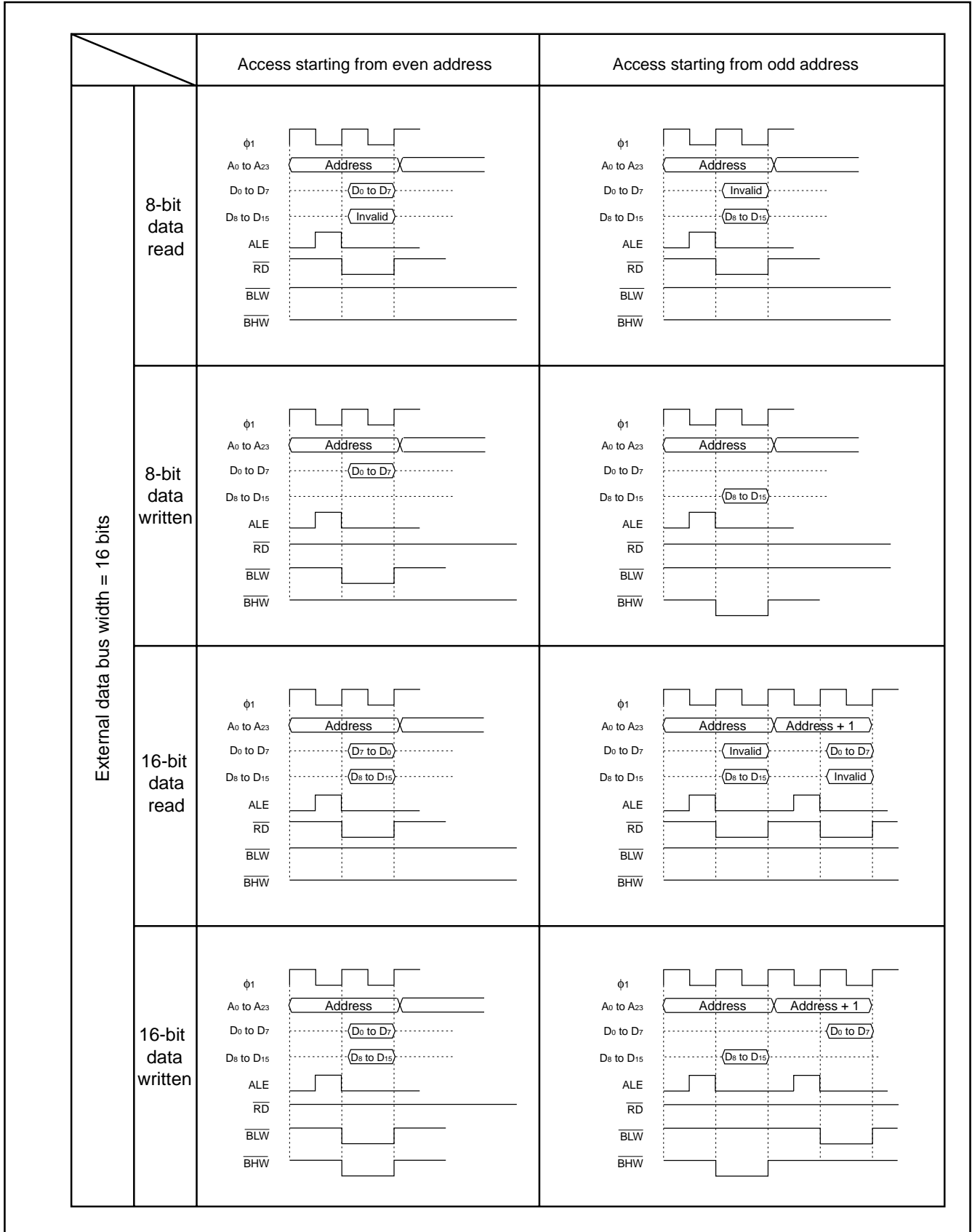

Fig. 14 Bus cycle waveform example for data access (access to external area) (1)

**MITSUBISHI MICROCOMPUTERS**  
**M37902FCCHP, M37902FGCHP, M37902FJCHP**

SHINGLE-CHIP 16-BIT CMOS MICROCOMPUTER

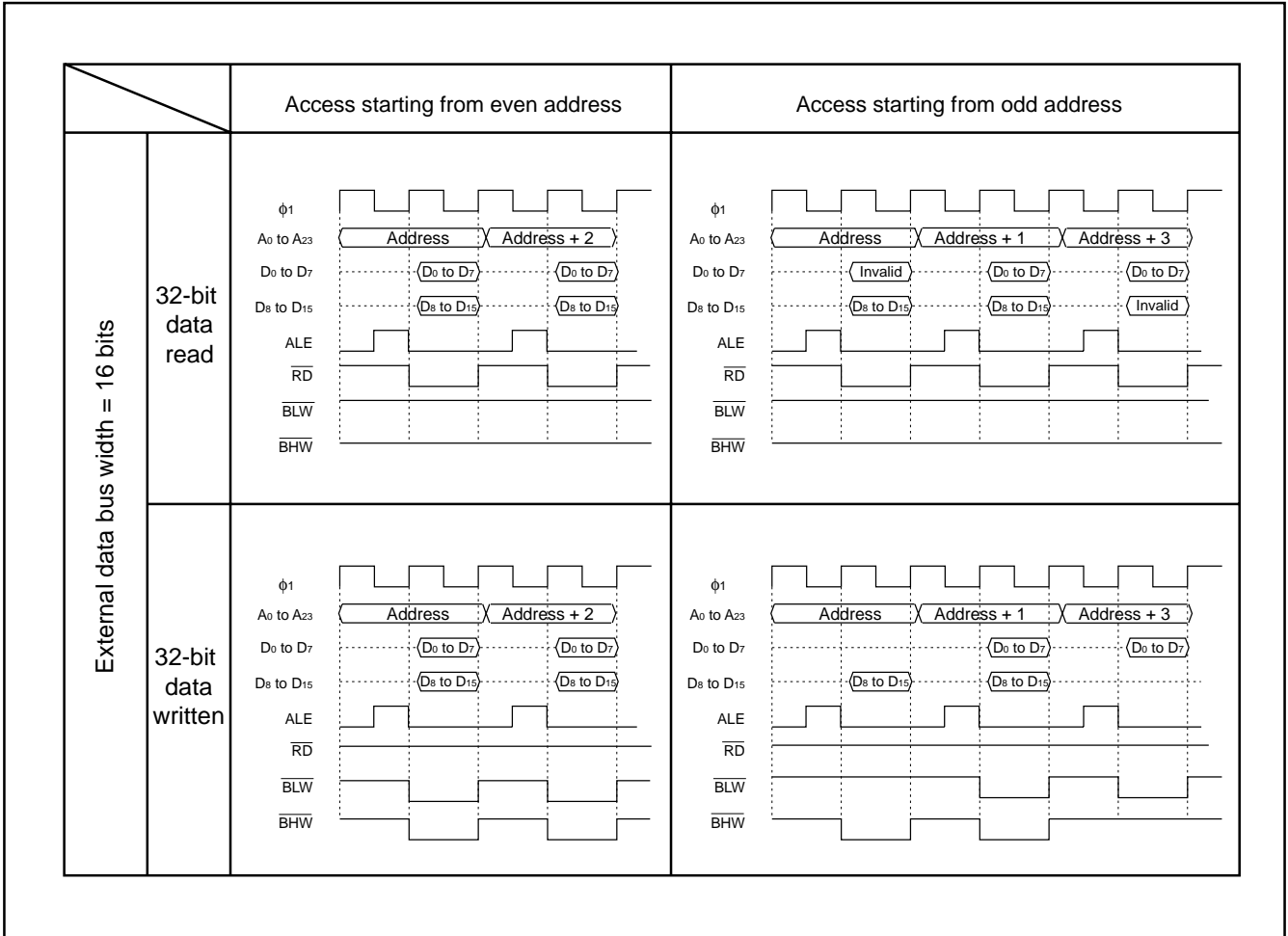

Fig. 15 Bus cycle waveform example for data access (access to external area) (2)

MITSUBISHI MICROCOMPUTERS  
**M37902FCCHP, M37902FGCHP, M37902FJCHP**

SHINGLE-CHIP 16-BIT CMOS MICROCOMPUTER

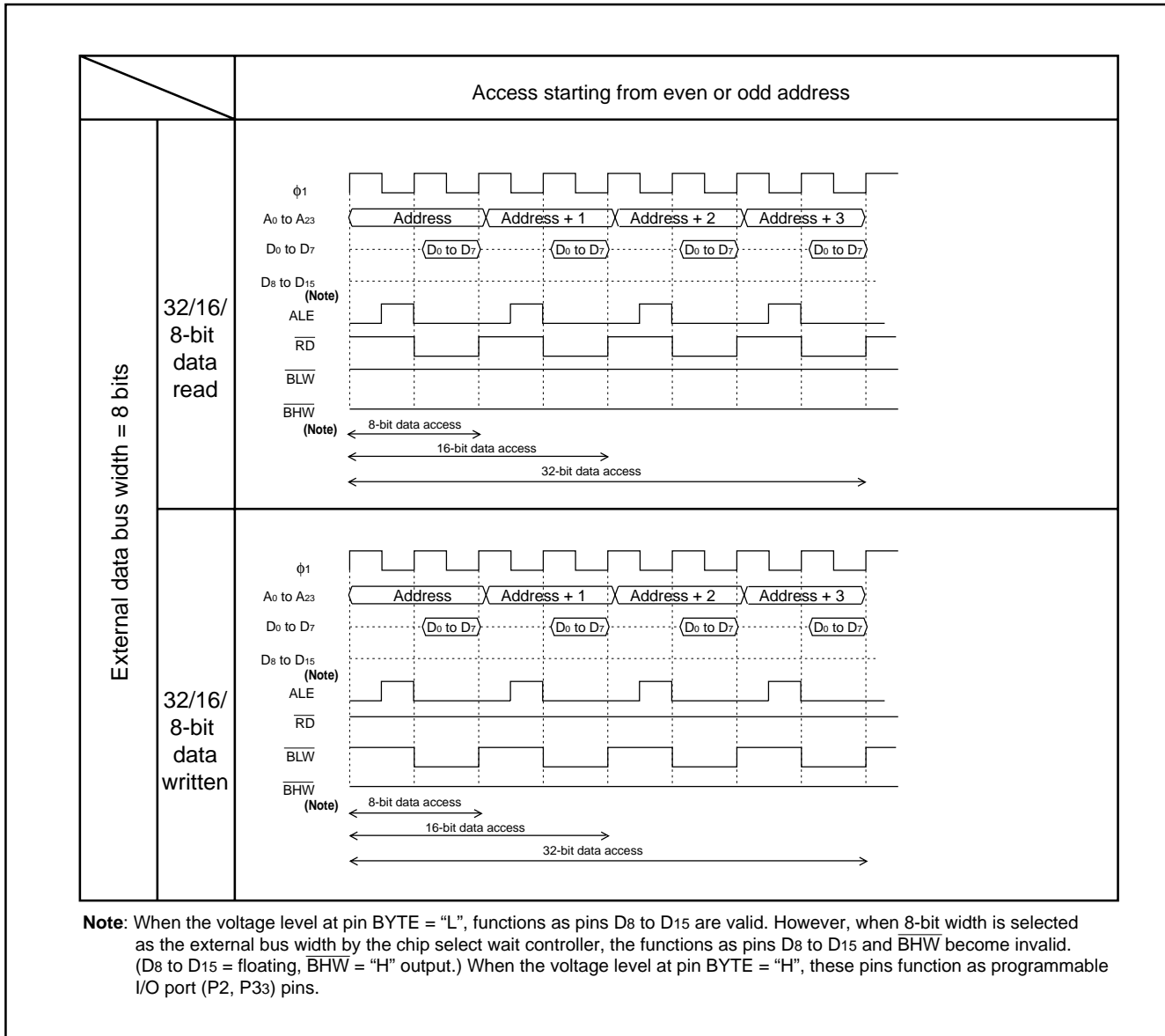

Fig. 16 Bus cycle waveform example for data access (access to external area) (3)



MITSUBISHI MICROCOMPUTERS

# M37902FCCHP, M37902FGCHP, M37902FJCHP

SHINGLE-CHIP 16-BIT CMOS MICROCOMPUTER

● **Number of bus cycles**

Figure 17 shows the bus cycle waveform at access to the internal area. Bit 7 of the processor mode register 1 (address 5F16) selects the number of bus cycles for the internal ROM: 3φ or 2φ. (This bit 7 is the internal ROM bus cycle select bit.) The internal RAM, SFRs (in-

ternal peripheral devices' control registers) are always accessed with 1 bus cycle = 2φ. Figure 18 shows the bus cycle waveform at access to the external area. The bus cycle select bits 0, 1 (See the note in Figure 18.) select the number of the bus cycles for each CSi area from 8 types of numbers.

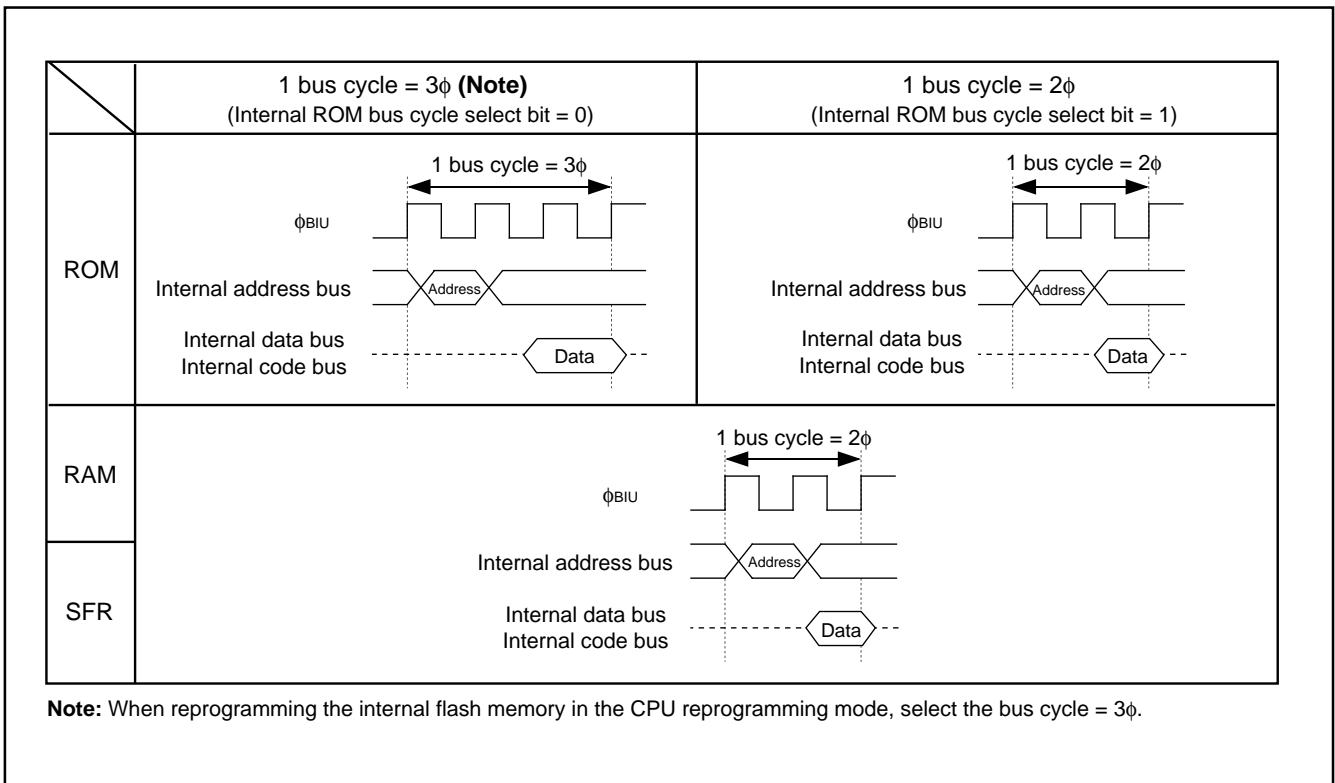

Fig. 17 Bus cycle waveform at access to internal area

MITSUBISHI MICROCOMPUTERS

# M37902FCCHP, M37902FGCHP, M37902FJCHP

SHINGLE-CHIP 16-BIT CMOS MICROCOMPUTER

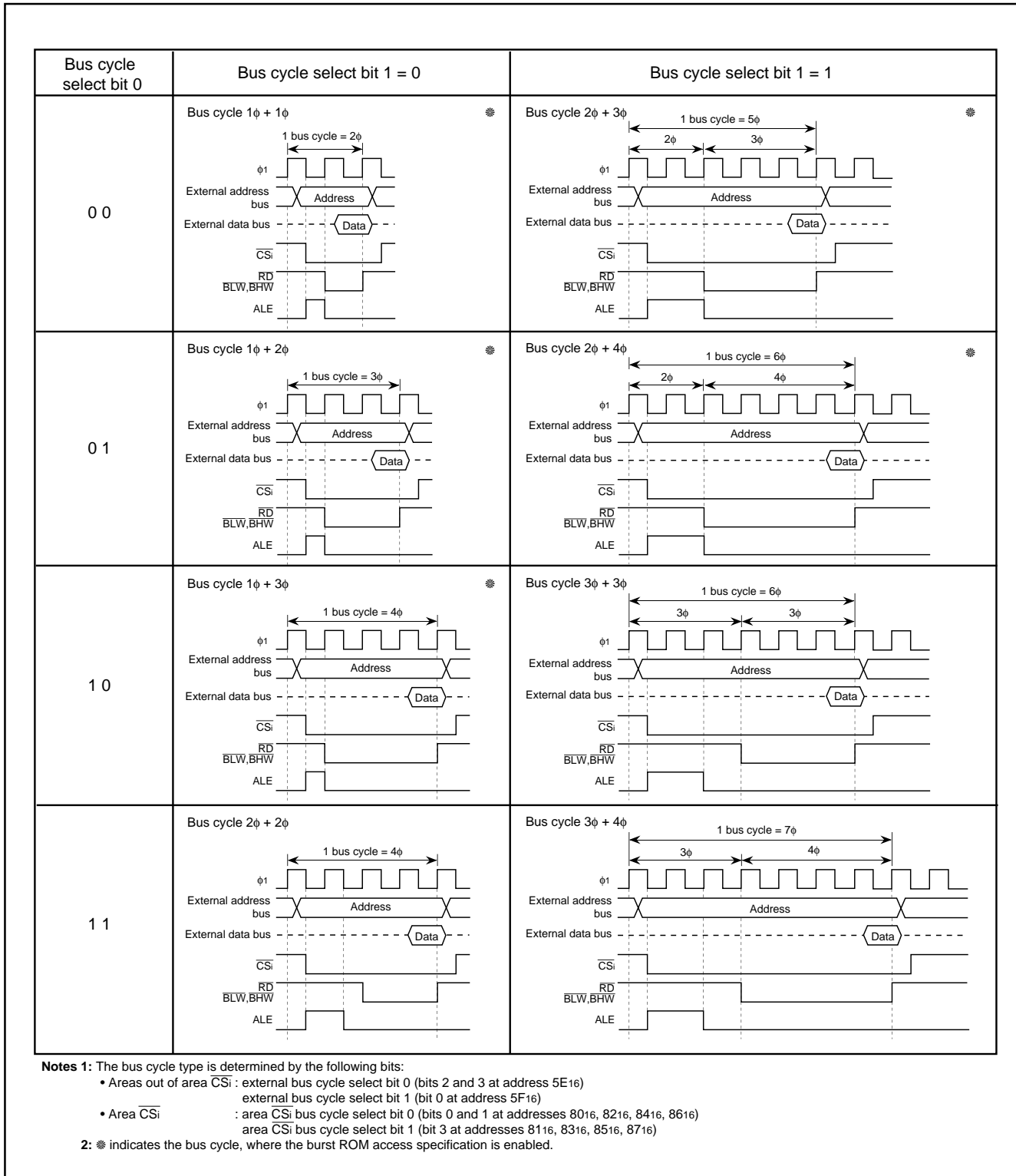

Fig. 18 Bus cycle types at access to external area

MITSUBISHI MICROCOMPUTERS

# M37902FCCHP, M37902FGCHP, M37902FJCHP

SHINGLE-CHIP 16-BIT CMOS MICROCOMPUTER

## ● Recovery cycle

A recovery cycle which is equivalent to 1 or 2 cycles of  $\phi_1$  can be inserted after each area  $\overline{CS}_i$ 's access cycle. Whether the recovery cycle is inserted or not is determined by the recovery cycle insert select bit of each  $\overline{CS}_i$  control register L (bit 6 at addresses 8016, 8216,

8416, 8616). Also, the number of the recovery cycles is selected by the recovery-cycle-insert-number select bit of the processor mode register 1 (bit 6 at address 5F16). Figure 19 shows a waveform example when a recovery cycle is inserted.

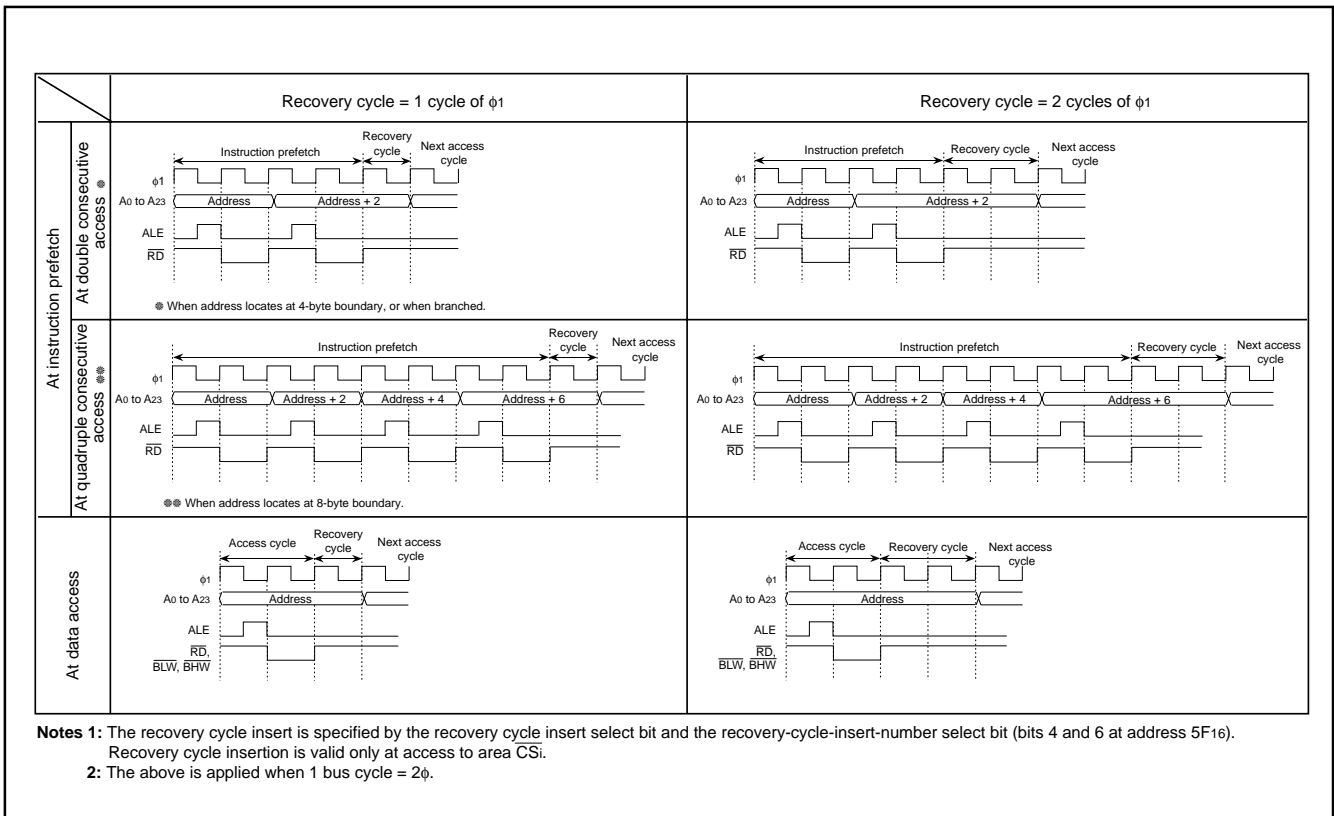

Fig. 19 Waveform example when recovery cycle is inserted

MITSUBISHI MICROCOMPUTERS

# M37902FCCHP, M37902FGCHP, M37902FJCHP

SHINGLE-CHIP 16-BIT CMOS MICROCOMPUTER

● **Burst ROM access**

When ROM supporting the burst ROM access has been allocated to area  $\overline{CS}_i$ , the burst ROM access can be specified. The burst ROM access is specified by each burst ROM access select bit of the  $\overline{CS}_i$  control register L (bit 5 at addresses 80<sub>16</sub>, 82<sub>16</sub>, 84<sub>16</sub>, 86<sub>16</sub>). The burst ROM access is valid only when the external data bus width = 16 bits with an instruction prefetched. In the other cases, the normal access is performed regardless of the contents of the burst ROM access select bit. The burst ROM access can be specified only in the case of \* in Figure 18.

Figure 20 shows a waveform example at burst ROM access. When an instruction is prefetched from the burst ROM, 8 bytes are fetched starting from an 8-byte boundary (the low-order 3 bits of address, A<sub>2</sub>, A<sub>1</sub>, A<sub>0</sub> = "000") in waveform (a). When branched, regardless of the 8-byte boundary of the branch destination address, access starting from the 4-byte boundary (the low-order 2 bits of address, A<sub>1</sub>, A<sub>0</sub> = "00") is performed in waveform (b). Once the 8-byte boundary has been selected, instructions will be prefetched in waveform (a) until a branch.

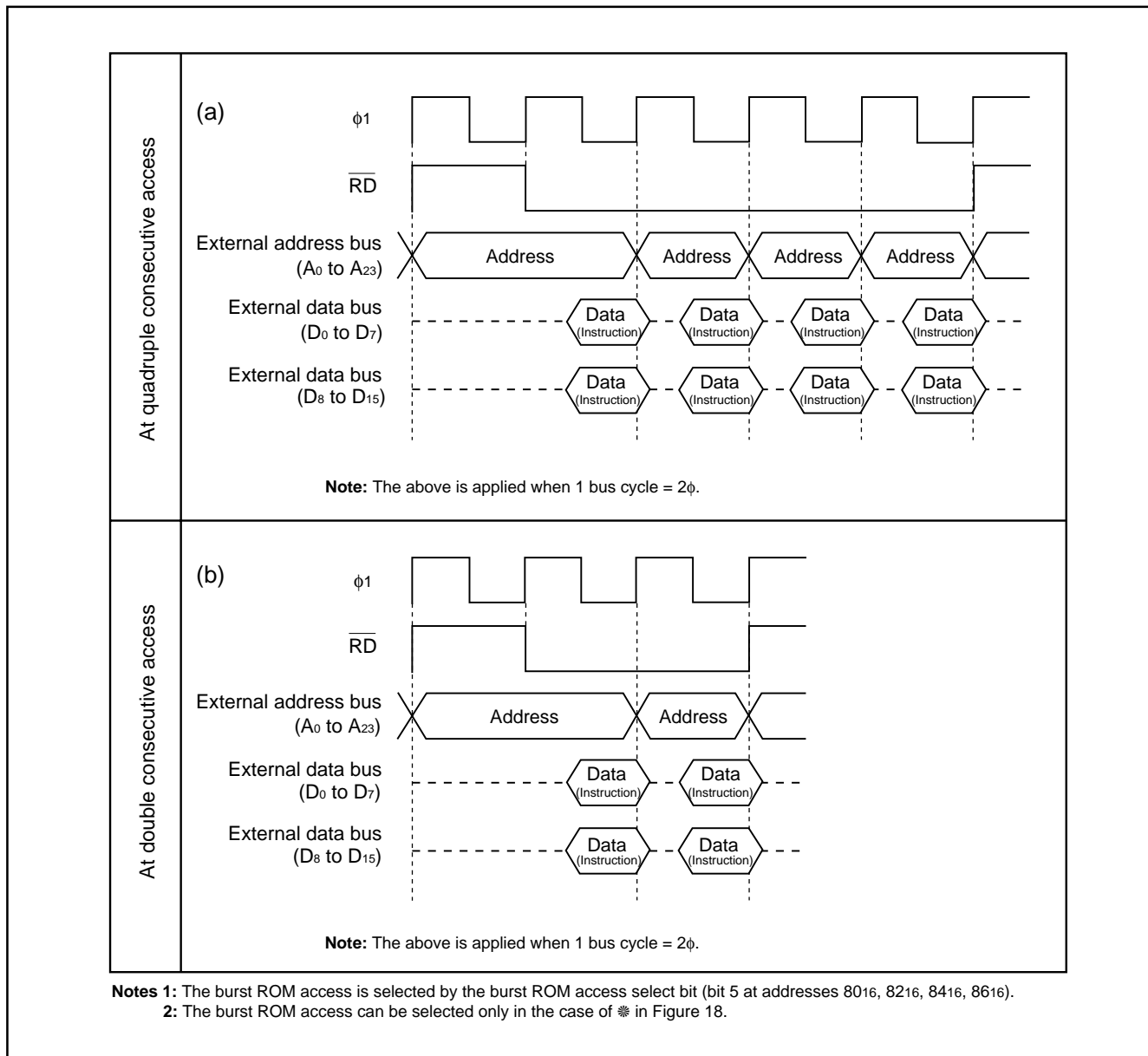

Fig. 20 Waveform example at burst ROM access

MITSUBISHI MICROCOMPUTERS

# M37902FCCHP, M37902FGCHP, M37902FJCHP

SHINGLE-CHIP 16-BIT CMOS MICROCOMPUTER

● **Address output selection**

As shown in Figure 21, the unnecessary state change of address output pins (A0 to A23) can be avoided, without outputting an address at access to the internal area.

When the address output select bit of the particular function select register 1 (bit 4 at address 6316) is set to "1", an address is output only at access to the external area. Also, at access to the internal

area, the address at the preceding access to the external area is retained. The address output start timing in this case is the half cycle of  $\phi_1$  later than that at the normal access (when the address output select bit = "0"). For the bit structure of the particular function select register 1, refer to the section on the standby function.

Also, at the normal access, an address is output at both of the access to the internal and external areas.

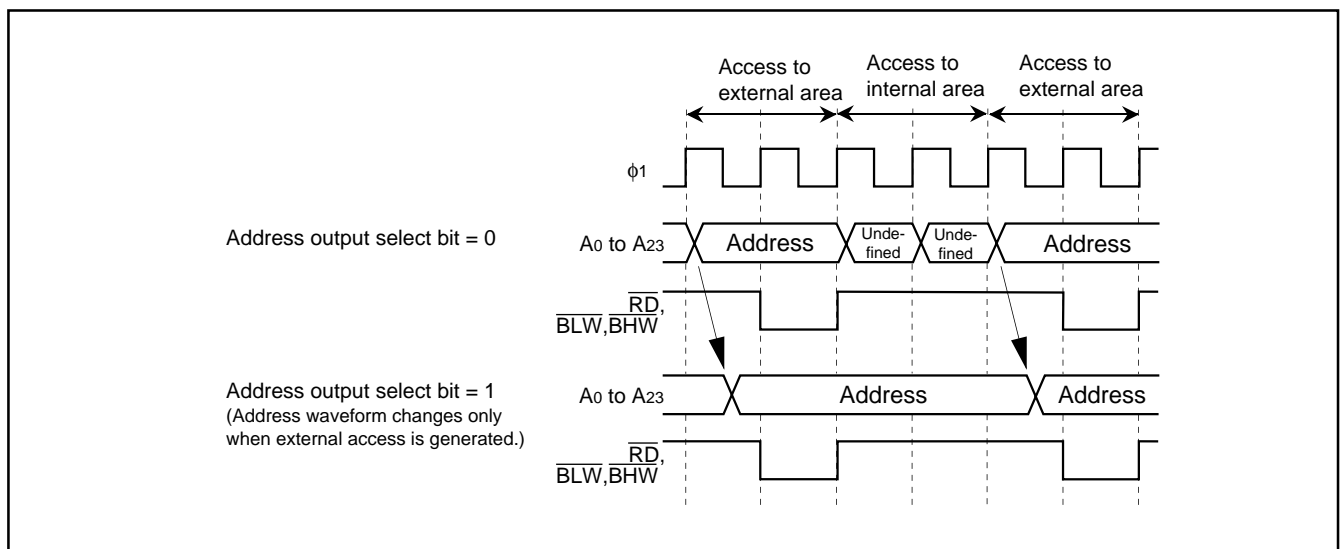

Fig. 21 Waveform example depending on address output function selection

MITSUBISHI MICROCOMPUTERS

# M37902FCCHP, M37902FGCHP, M37902FJCHP

SHINGLE-CHIP 16-BIT CMOS MICROCOMPUTER

● **Area multiplication**

When area  $\overline{CS}_2$ 's external data bus width = 8 bits with the multiplexed bus select bit of the  $\overline{CS}_2$  control register H (bit 5 at address 8516) = "1", the external bus type can be changed to the multiplexed bus type only at access to area  $\overline{CS}_2$ . In this case, the low-order 8 bits

of an address (LA0 to LA7) are output, and the low-order 8 bits of data (D0 to D7) are input/output with the time-sharing method, respectively.

Figure 22 shows a waveform example of area multiplication for each bus cycle. Do not select the area multiplication function for a bus cycle not shown in Figure 22.

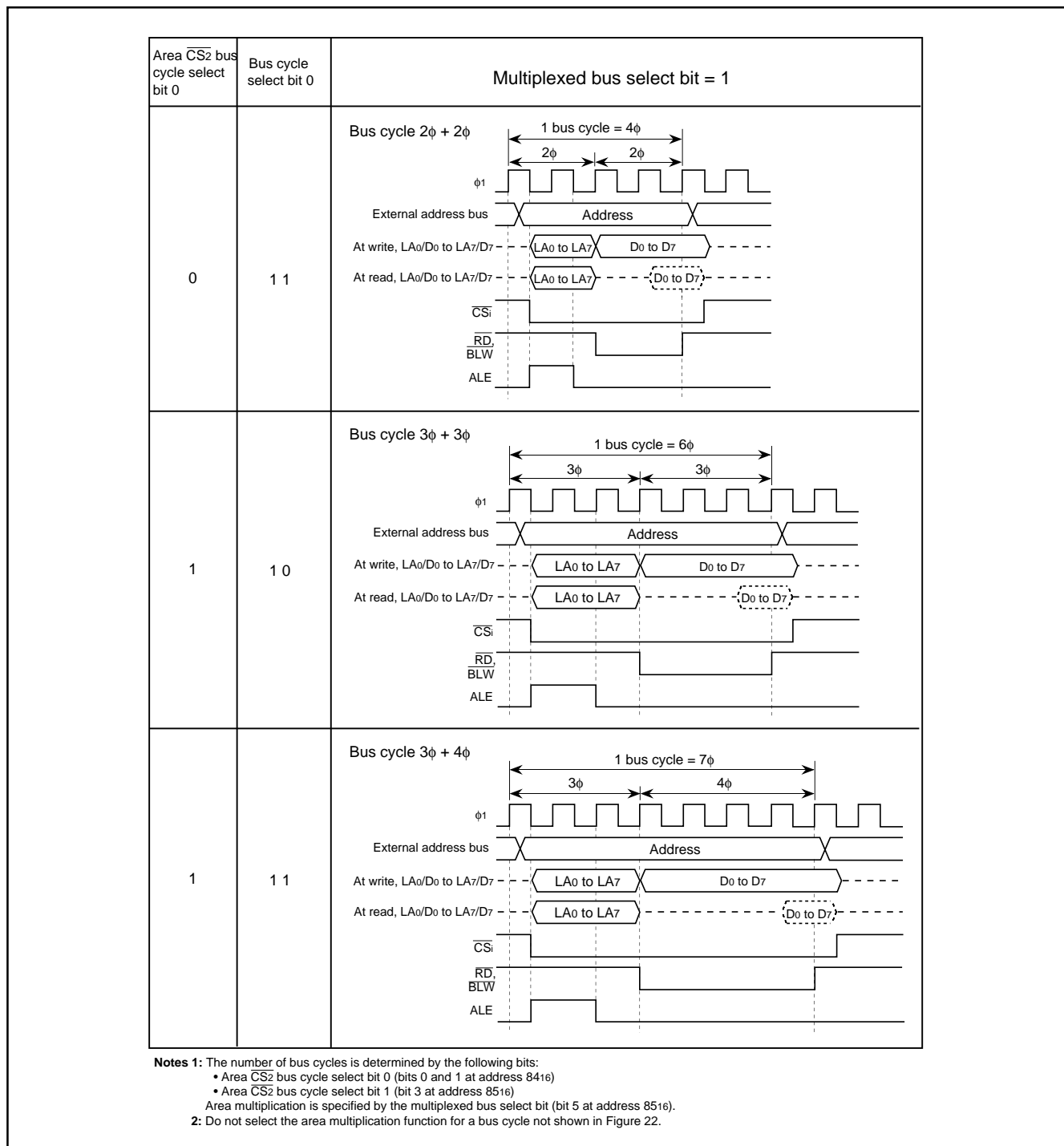

Fig. 22 Waveform example of area multiplication for each bus cycle



MITSUBISHI MICROCOMPUTERS

# M37902FCCHP, M37902FGCHP, M37902FJCHP

SINGLE-CHIP 16-BIT CMOS MICROCOMPUTER

Table 3. Selection method of processor mode

MD0	Processor mode bits (Note 1)	Processor mode	Description
V <sub>SS</sub>	00	Single-chip mode	After reset is removed, the single-chip mode is selected. By changing the processor mode bits' contents by software, the memory expansion mode or microprocessor mode can be selected.
	01	Memory expansion mode	
	10	Microprocessor mode	
V <sub>CC</sub>	10 (Note 2)	Microprocessor mode	After reset is removed, the microprocessor mode is selected.

**Notes 1:** Processor mode bits = bits 0 and 1 of the processor mode register 0 (address 5E<sub>16</sub>)

**2:** While the V<sub>CC</sub> level voltage is applied to pin MD0, the processor mode bits are fixed to "10".

Table 4. Each bus control signal's function

Signal	I/O	Function	Remarks
RD	Output	Read signal. Outputs "L" at read from the external area.	
BLW BHW	Output	Write signal. Outputs "L" at write to the external area.	For operation differences between BLW and BHW depending on the external data bus width, see Table 5.
ALE	Output	Address latch enable signal. Outputs "H" level pulse in the period just before signals RD, BLW, BHW become "L". This is used to latch an address in an external circuit.	In order to latch an address with signal ALE, do as follows: • While ALE = "H", be sure to open a latch, so the address will pass it. • While ALE = "L", be sure to hold the address.
φ <sub>1</sub>	Output	Internal standard clock's output. Outputs system clock (f <sub>sys</sub> ).	
RDY	Input	Ready signal. The "L" level period of the last φ <sub>1</sub> in the access cycle for the external area (in other words, "L" level period of RD, BLW, BHW) will be extended while "L" level voltage is applied to this pin.	
HOLD	Input	Hold request signal. Appliance of "L" level voltage will generate a hold request; appliance of "H" level voltage will request to terminate the hold state.	Acceptance and termination of a hold request is performed at completion of the bus cycle while the BIU operates. In the hold state, A <sub>0</sub> –A <sub>23</sub> , D <sub>0</sub> –D <sub>15</sub> , RD, BLW, BHW, ALE, CS <sub>0</sub> –CS <sub>3</sub> enter the floating state. At termination of the hold state, simultaneously with the timing when HLD <sub>A</sub> becomes "H" level, the above floating state is terminated. Then, bus access will be restarted 1 cycle of φ <sub>1</sub> after.
HDLA	Output	Hold acknowledge signal. Outputs "L" in the hold state.	In the hold state, also, the CPU operates with access to the internal area. If the CPU accesses the external area, in the hold state, the CPU stops its operation.
CS <sub>0</sub> –CS <sub>3</sub>	Output	Chip select signal. Outputs "L" in access to the specified chip select area.	For details, refer to the section on the chip select wait controller.
BYTE	Input	Input signal to select the external data bus width. When this pin's level = V <sub>SS</sub> , 16-bit width will be selected; and when V <sub>CC</sub> , 8-bit width will be selected.	When BYTE = V <sub>SS</sub> level, by the register setting, each chip select area (CS <sub>1</sub> to CS <sub>3</sub> ) can have the 8-bit data bus, independently. For details, refer to the section on the chip select wait controller.



MITSUBISHI MICROCOMPUTERS

# M37902FCCHP, M37902FGCHP, M37902FJCHP

SINGLE-CHIP 16-BIT CMOS MICROCOMPUTER

Table 5. Relationship between processor modes, memory area, and port function (1)

		Single-chip mode	Memory expansion mode	Microprocessor mode
Mode (Note 1)	Pin MD0	Vss level voltage is applied	Vss level voltage is applied	Vcc level voltage is applied
	Processor mode bits (Note 2)	00	01	10
Memory area	SFR area	SFR area	SFR area	SFR area
	Internal RAM area	Internal RAM area	Internal RAM area	Internal RAM area
	Internal ROM area	Internal ROM area	Internal ROM area	External memory area
	Other area	(Do not access.)	External memory area	External memory area
Port pins P100 to P107		I/O port pins P100 to P107	Low-order address (A0 to A7) is output.	Low-order address (A0 to A7) is output.
Port pins P110 to P117		I/O port pins P110 to P117	Middle-order address (A8 to A15) is output. I/O port pins P110 to P117 (Note 3)	Middle-order address (A8 to A15) is output. I/O port pins P110 to P117 (Note 3)
Port pins P00 to P07		I/O port pins P00 to P07	High-order address (A16 to A23) is output. I/O port pins P00 to P07 (Note 3)	High-order address (A16 to A23) is output. I/O port pins P00 to P07 (Note 3)
Port pins P10 to P17	External data bus width = 16 bits	I/O port pins P10 to P17	Low-order data (D0 to D7, data at even address) is input/output.	Low-order data (D0 to D7, data at even address) is input/output.
	External data bus width = 8 bits		Low-order data (D0 to D7, data at even/odd address) is input/output.	Low-order data (D0 to D7, data at even/odd address) is input/output.
			Low-order address (LA0 to LA7) is output. Low-order data (D0 to D7, data at even/odd address) is input/output (Note 4).	Low-order address (LA0 to LA7) is output. Low-order data (D0 to D7, data at even/odd address) is input/output (Note 4).
Port pins P20 to P27	External data bus width = 16 bits	I/O port pins P20 to P27	High-order data (D8 to D15, data at odd address) is input/output.	High-order data (D8 to D15, data at odd address) is input/output.
	External data bus width = 8 bits		I/O port pins P20 to P27 (Note 5)	I/O port pins P20 to P27 (Note 5)
Port pin P30		I/O port pin P30	I/O port pin P30 Ready signal $\overline{RDY}$ is input (Note 6).	Ready signal $\overline{RDY}$ is input. I/O port pin P30 (Note 6)
Port pin P31		I/O port pin P31	Read signal $\overline{RD}$ is output.	Read signal $\overline{RD}$ is output
Port pin P32	External data bus width = 16 bits	I/O port pin P32	Write signal $\overline{BLW}$ (write to even address) is output.	Write signal $\overline{BLW}$ (write to even address) is output.
	External data bus width = 8 bits		Write signal $\overline{BLW}$ (write to even/odd address) is output.	Write signal $\overline{BLW}$ (write to even/odd address) is output.
Port pin P33	External data bus width = 16 bits	I/O port pin P33	Write signal $\overline{BHW}$ (write to odd address) is output.	Write signal $\overline{BHW}$ (write to odd address) is output.
	External data bus width = 8 bits		I/O port pin P33 (Note 5)	I/O port pin P33 (Note 5)

MITSUBISHI MICROCOMPUTERS

# M37902FCCHP, M37902FGCHP, M37902FJCHP

SINGLE-CHIP 16-BIT CMOS MICROCOMPUTER

Table 6. Relationship between processor modes, memory area, and port function (2)

	Single-chip mode	Memory expansion mode	Microprocessor mode
Port pin P40	I/O port pin P40	I/O port pin P40 ----- Address latch enable signal ALE is output ( <b>Note 6</b> ).	Address latch enable signal ALE is output. ----- I/O port pin P40 ( <b>Note 6</b> )
Port pin P41	I/O port pin P41 ----- Clock $\phi_1$ is output ( <b>Note 6</b> ).	I/O port pin P41 ----- Clock $\phi_1$ is output ( <b>Note 6</b> ).	Clock $\phi_1$ is output. ----- I/O port pin P41 ( <b>Note 6</b> )
Port pin P42	I/O port pin P42	I/O port pin P42 ----- Hold acknowledge signal $\overline{\text{HLDA}}$ is output ( <b>Note 6</b> ).	Hold acknowledge signal $\overline{\text{HLDA}}$ is output. ----- I/O port pin P42 ( <b>Note 6</b> )
Port pin P43	I/O port pin P43	I/O port pin P43 ----- Hold request signal $\overline{\text{HOLD}}$ is input ( <b>Note 6</b> ).	Hold request signal Signal $\overline{\text{HOLD}}$ is input. ----- I/O port pin P43 ( <b>Note 6</b> )
Port pin P44	I/O port pin P44	I/O port pin P44 ----- Chip select signal $\overline{\text{CS}}_0$ is output ( <b>Note 7</b> ).	Chip select signal $\overline{\text{CS}}_0$ is output.
Port pins P45 to P47	I/O port pins P45 to P47	I/O port pins P45 to P47 ----- Chip select signals $\overline{\text{CS}}_1$ to $\overline{\text{CS}}_3$ are output ( <b>Note 8</b> ).	I/O port pin P45 to P47 ----- Chip select signals $\overline{\text{CS}}_1$ to $\overline{\text{CS}}_3$ are output ( <b>Note 8</b> ).

**Notes 1:** For details of the processor mode setting, see Table 3.

**2:** Processor mode bits = bits 0 and 1 of the processor mode register 0 (address 5E16).

**3:** The middle-order/high-order address output pins in the memory expansion or microprocessor mode can be switched to I/O port pins by the address/port switch select bits of the port function control register (bits 2 to 0 at address 9216).

**4:** When the external data bus width for the chip select area,  $\overline{\text{CS}}_2$ , has been set to 8 bits, only in the access to area  $\overline{\text{CS}}_2$ , by the multiplexed bus select bit of the  $\overline{\text{CS}}_2$  control register H (bit 5 at address 8516), a multiplexed bus which performs the following operations with the time-sharing method is realized:

- Output of address LA0 to LA7
- Input/Output of data D0 to D7

**5:** When one of areas  $\overline{\text{CS}}_1/\overline{\text{CS}}_2/\overline{\text{CS}}_3$  is accessed under the following conditions, pins D8 to D15 enter the floating state, and pin  $\overline{\text{BHW}}$  outputs "H" level. (They do not become I/O port pins.)

- Pin BYTE is at Vss level.
- One of bit 2s at addresses 8216, 8416, 8616 (the external data bus width select bit of the  $\overline{\text{CS}}_1/\overline{\text{CS}}_2/\overline{\text{CS}}_3$  control register L) is set to "1" (external data bus width = 8 bits).

**6:** In the memory expansion mode, by the corresponding select bits of the processor mode register 0 and 1 (addresses 5E16, 5F16), port pins P30, P40 to P43 can operate as pins for  $\overline{\text{RDY}}$  input, ALE output,  $\phi_1$  output,  $\overline{\text{HLDA}}$  output,  $\overline{\text{HOLD}}$  input, respectively.

In the microprocessor mode, by the above select bits, the above pins ( $\overline{\text{RDY}}$ , ALE,  $\phi_1$ ,  $\overline{\text{HLDA}}$ ,  $\overline{\text{HOLD}}$ ) can operate as port pins P30, P40 to P43, respectively.

In the single-chip mode, port pin P41 can operate as the  $\phi_1$  output pin by the above select bits.

**7:** In the memory expansion mode, port pin P44 can operate as the  $\overline{\text{CS}}_0$  output pin by the  $\overline{\text{CS}}_0$  output select bit of the  $\overline{\text{CS}}_0$  control register L (bit 7 at address 8016).

**8:** In the memory expansion and microprocessor modes, port pins P45 to P47 can operate as the  $\overline{\text{CS}}_1/\overline{\text{CS}}_2/\overline{\text{CS}}_3$  output pins by the  $\overline{\text{CS}}_i$  output select bits (i = 1 to 3) (bit 7s at addresses 8216, 8416, 8616).

MITSUBISHI MICROCOMPUTERS

# M37902FCCHP, M37902FGCHP, M37902FJCHP

SINGLE-CHIP 16-BIT CMOS MICROCOMPUTER

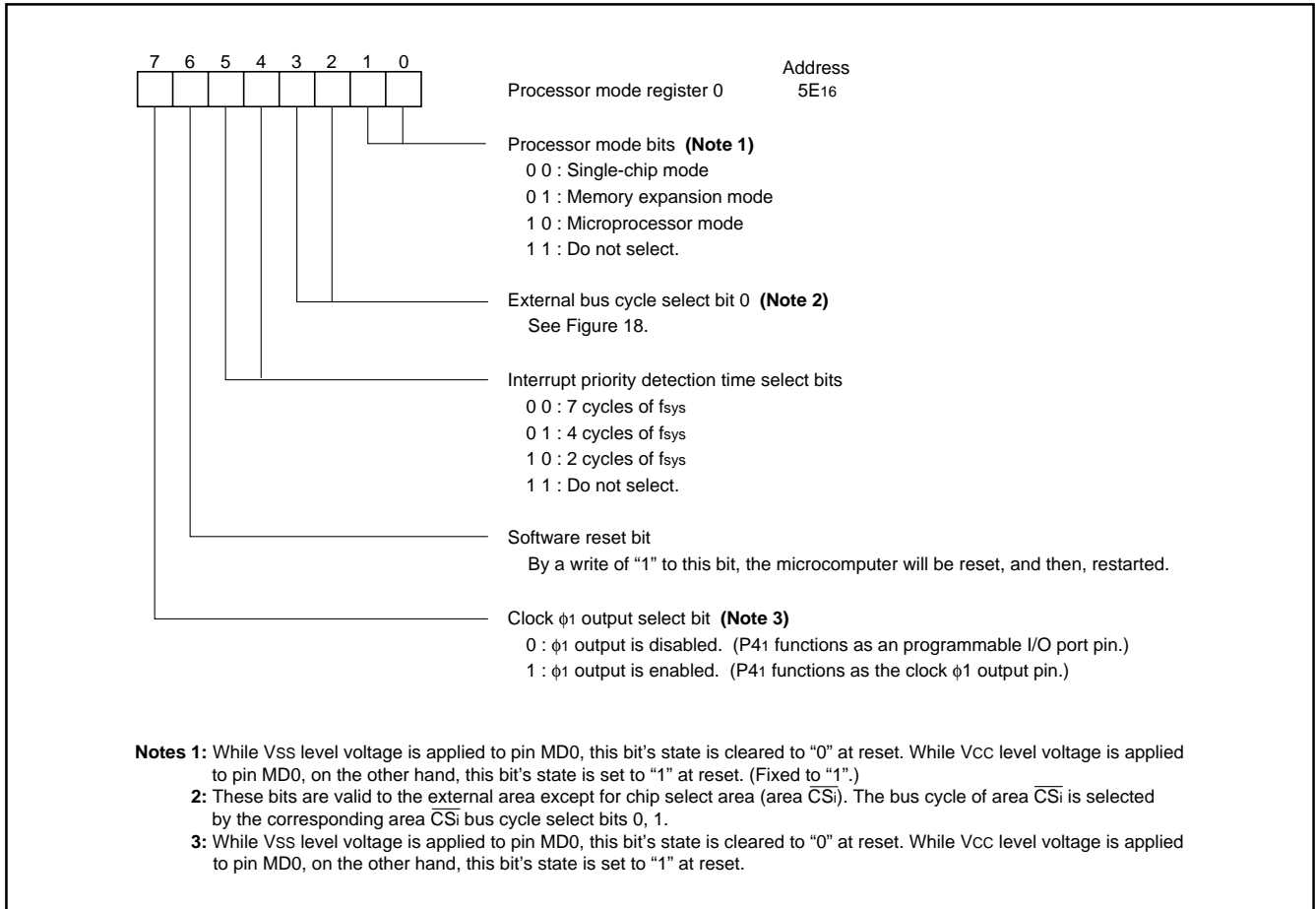

Fig. 24 Bit configuration of processor mode register 0

MITSUBISHI MICROCOMPUTERS

# M37902FCCHP, M37902FGCHP, M37902FJCHP

SINGLE-CHIP 16-BIT CMOS MICROCOMPUTER

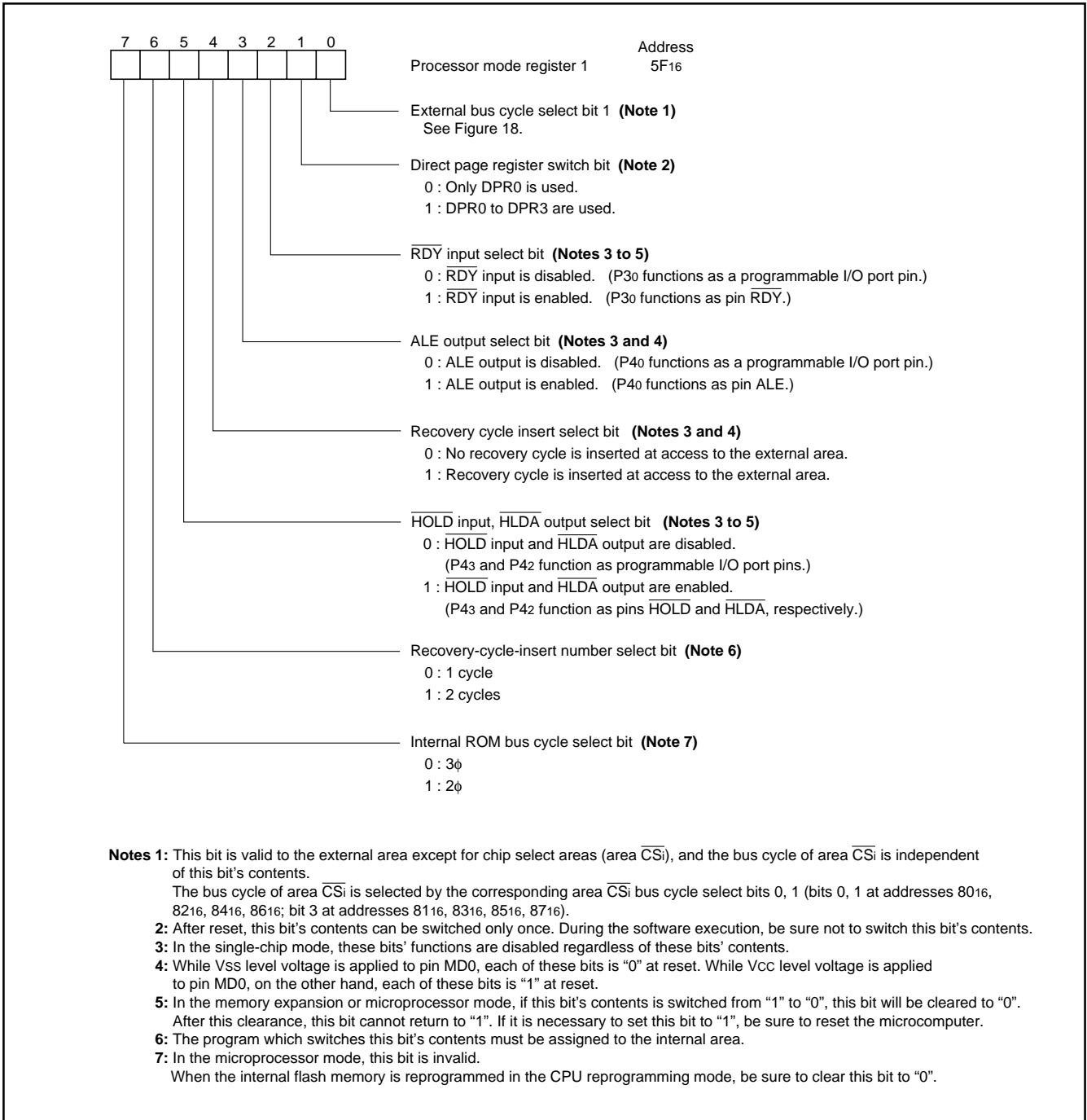

Fig. 25 Bit configuration of processor mode register 1

MITSUBISHI MICROCOMPUTERS

# M37902FCCHP, M37902FGCHP, M37902FJCHP

SINGLE-CHIP 16-BIT CMOS MICROCOMPUTER

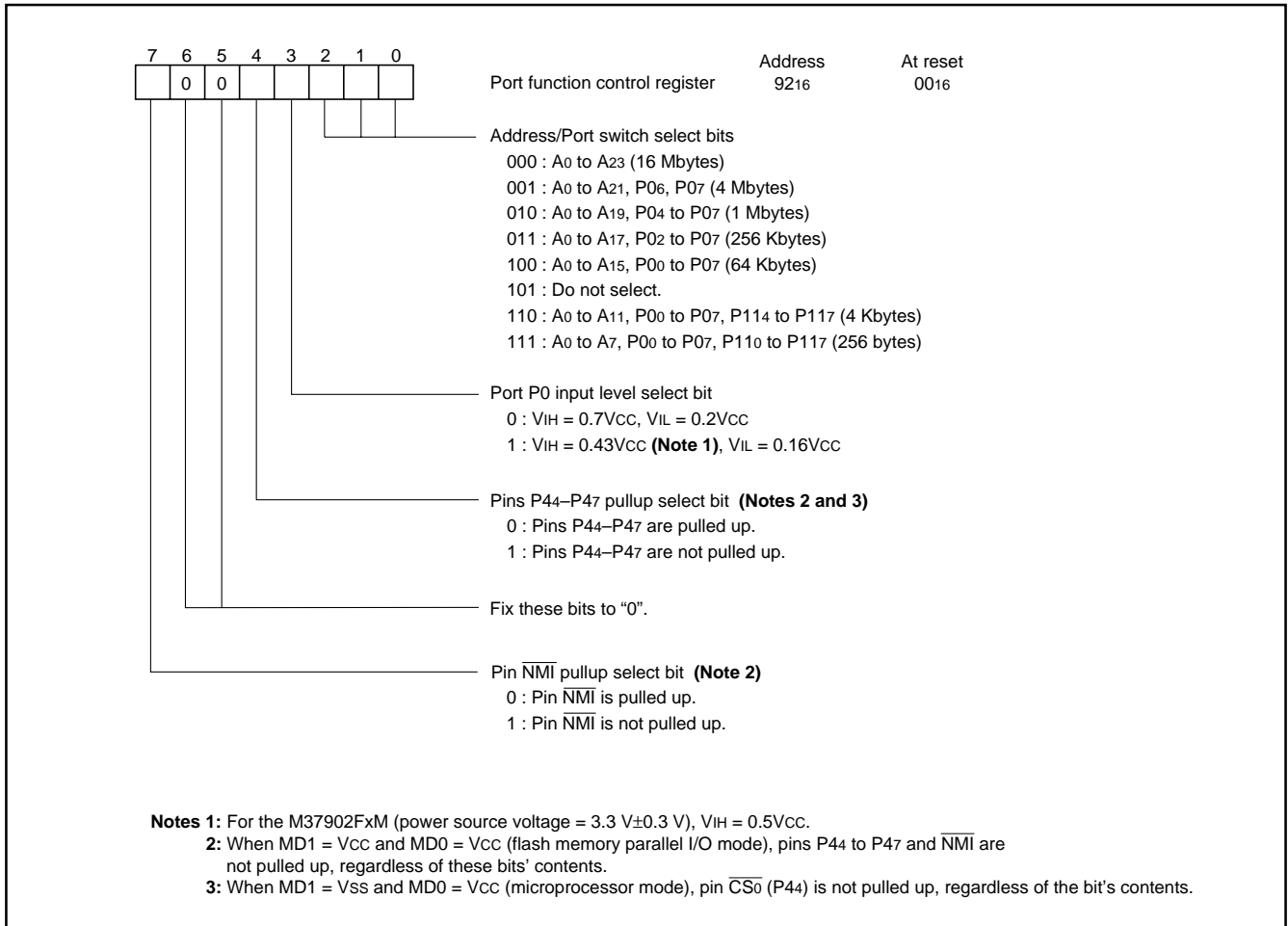

Fig. 26 Bit configuration of port function control register

MITSUBISHI MICROCOMPUTERS

# M37902FCCHP, M37902FGCHP, M37902FJCHP

SINGLE-CHIP 16-BIT CMOS MICROCOMPUTER

## Chip select wait controller

By the control of the chip select wait controller (CSWC), the chip select function for the maximum of 4 blocks can be set at the bus access to the external area.

Also, by the setting of the CSWC, port pins P44 to P47 can operate as chip select output pins ( $\overline{CS}_0$  to  $\overline{CS}_3$ ).

Figure 27 shows a chip select output waveform example.

This chip select function determines the following items of the chip select area: start address, address's block size, wait number, external data bus width,  $\overline{RDY}$  control validity, burst ROM specification, recovery cycle insertion validity, and area multiplication validity.

For the external area except for areas  $\overline{CS}_0$  to  $\overline{CS}_3$ , the processor mode registers 0, 1 determine the above items. After reset is removed, when the microcomputer starts its operation in the microprocessor mode, area  $\overline{CS}_0$  is automatically selected.

Table 7 lists the function of areas  $\overline{CS}_0$  to  $\overline{CS}_3$ .

Figure 28 shows the bit configuration of the  $\overline{CS}_0/\overline{CS}_1/\overline{CS}_2/\overline{CS}_3$  control register Ls. These registers determine the following items of a device to be connected: wait number, external data bus width (**Note:** The external data bus width of area  $\overline{CS}_0$  is determined by pin BYTE's level.),  $\overline{RDY}$  control validity, burst ROM access specification, recovery cycle insertion validity, and output validity of  $\overline{CS}_0$  to  $\overline{CS}_3$ .

Figure 29 shows the bit configuration of the  $\overline{CS}_0/\overline{CS}_1/\overline{CS}_2/\overline{CS}_3$  control register Hs. These registers determine block size, etc. of an external area to be connected. For areas  $\overline{CS}_0$  to  $\overline{CS}_2$ , by selecting mode 1 with the area  $\overline{CS}_k$  setting mode select bit, an chip select area can be set to the external area in bank 0.

Figures 30 shows the bit configuration of the area  $\overline{CS}_0/\overline{CS}_1/\overline{CS}_2/\overline{CS}_3$  start address registers. For details of these addresses' setting, see Figures 31 to 33.

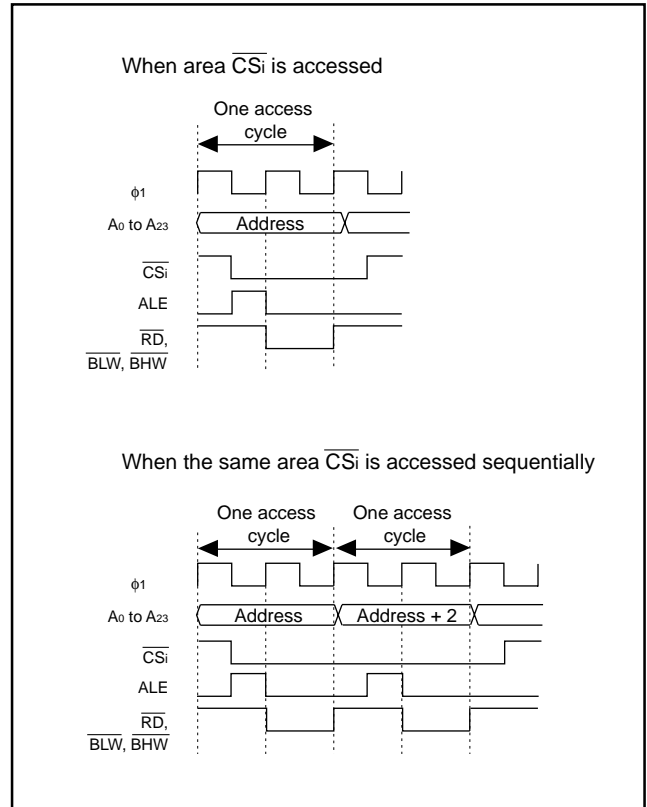

Fig. 27 Chip select output waveform example

MITSUBISHI MICROCOMPUTERS

# M37902FCCHP, M37902FGCHP, M37902FJCHP

SINGLE-CHIP 16-BIT CMOS MICROCOMPUTER

Table 7. Function of areas  $\overline{CS}_0$  to  $\overline{CS}_3$

	$\overline{CS}_0$		$\overline{CS}_1, \overline{CS}_2$		$\overline{CS}_3$	External area except for $\overline{CS}_0$ to $\overline{CS}_3$
	Mode 0	Mode 1	Mode 0	Mode 1		
Space where start address can be set	Banks 216 to FE16	Bank 016	Banks 216 to FE16	Bank 016	Banks 216 to FE16	
Block size	128 Kbytes, 256 Kbytes, 512 Kbytes, 1 Mbytes, 2 Mbytes, 4 Mbytes, or 8 Mbytes	128 Kbytes, 256 Kbytes, 512 Kbytes, 1 Mbytes, 2 Mbytes, 4 Mbytes, or 8 Mbytes	128 Kbytes, 256 Kbytes, 512 Kbytes, 1 Mbytes, 2 Mbytes, 4 Mbytes, or 8 Mbytes	4 Kbytes or 8 Kbytes	128 Kbytes, 256 Kbytes, 512 Kbytes, 1 Mbytes, 2 Mbytes, 4 Mbytes, or 8 Mbytes	
Bus cycle	Bus cycle: •1 $\phi$ + 1 $\phi$ •1 $\phi$ + 2 $\phi$ •1 $\phi$ + 3 $\phi$ •2 $\phi$ + 2 $\phi$ •2 $\phi$ + 3 $\phi$ •2 $\phi$ + 4 $\phi$ •3 $\phi$ + 3 $\phi$ •3 $\phi$ + 4 $\phi$ (Selected by bits 0, 1 at address 8016 and bit 3 at address 8116.)		Bus cycle: •1 $\phi$ + 1 $\phi$ •1 $\phi$ + 2 $\phi$ •1 $\phi$ + 3 $\phi$ •2 $\phi$ + 2 $\phi$ •2 $\phi$ + 3 $\phi$ •2 $\phi$ + 4 $\phi$ •3 $\phi$ + 3 $\phi$ •3 $\phi$ + 4 $\phi$ (Selected by bits 0, 1 at addresses 8216, 8416 and bit 3 at addresses 8316, 8516.)		Bus cycle: •1 $\phi$ + 1 $\phi$ •1 $\phi$ + 2 $\phi$ •1 $\phi$ + 3 $\phi$ •2 $\phi$ + 2 $\phi$ •2 $\phi$ + 3 $\phi$ •2 $\phi$ + 4 $\phi$ •3 $\phi$ + 3 $\phi$ •3 $\phi$ + 4 $\phi$ (Selected by bits 0, 1 at address 8616 and bit 3 at address 8716.)	Bus cycle: •1 $\phi$ + 1 $\phi$ •1 $\phi$ + 2 $\phi$ •1 $\phi$ + 3 $\phi$ •2 $\phi$ + 2 $\phi$ •2 $\phi$ + 3 $\phi$ •2 $\phi$ + 4 $\phi$ •3 $\phi$ + 3 $\phi$ •3 $\phi$ + 4 $\phi$ (Selected by bits 2, 3 at address 5E16 and bit 0 at address 5F16.)
External data bus width	Determined by pin BYTE's level.		When BYTE = Vss level, 8-bit width or 16-bit width can be selected arbitrary ( <b>Note 1</b> ). (Selected by bit 2 at addresses 8216, 8416.)		When BYTE = Vss level, 8-bit width or 16-bit width can be selected arbitrary ( <b>Note 1</b> ). (Selected by bit 2 at address 8616.)	Determined by pin BYTE's level
$\overline{RDY}$ control	Valid (Selected by bit 2 at address 5F16 and bit 3 at address 8016.)		Valid (Selected by bit 2 at address 5F16 and bit 3 at addresses 8216, 8416.)		Valid (Selected by bit 2 at address 5F16 and bit 3 at address 8616.)	Valid (Selected by bit 2 at address 5F16.)
Burst ROM access ( <b>Notes 2, 3</b> )	Available.		Available.		Available.	Not available.
Recovery cycle insertion	Available.		Available.		Available.	Available.
Area multiplexed bus access ( <b>Note 3</b> )	Not available.		$\overline{CS}_1$ : Not available. $\overline{CS}_2$ : Available. ( <b>Note 4</b> )		Not available.	Not available.
Address output selection ( <b>Note 5</b> )	Available.		Available.		Available.	Available.

**Notes 1:** When BYTE = Vcc level, the external data bus width is fixed to 8 bits.

**2:** Burst ROM access is valid only when the external data bus width is 16 bits at instruction prefetch.

**3:** Burst ROM access and area multiplexed bus access cannot be used at the same time.

**4:** Valid only when area  $\overline{CS}_2$  is accessed with the 8-bit external data bus width.

**5:** Selected by the address output select bit (bit 4 at address 6316). The address output selection for each area is not available.

MITSUBISHI MICROCOMPUTERS

# M37902FCCHP, M37902FGCHP, M37902FJCHP

SINGLE-CHIP 16-BIT CMOS MICROCOMPUTER

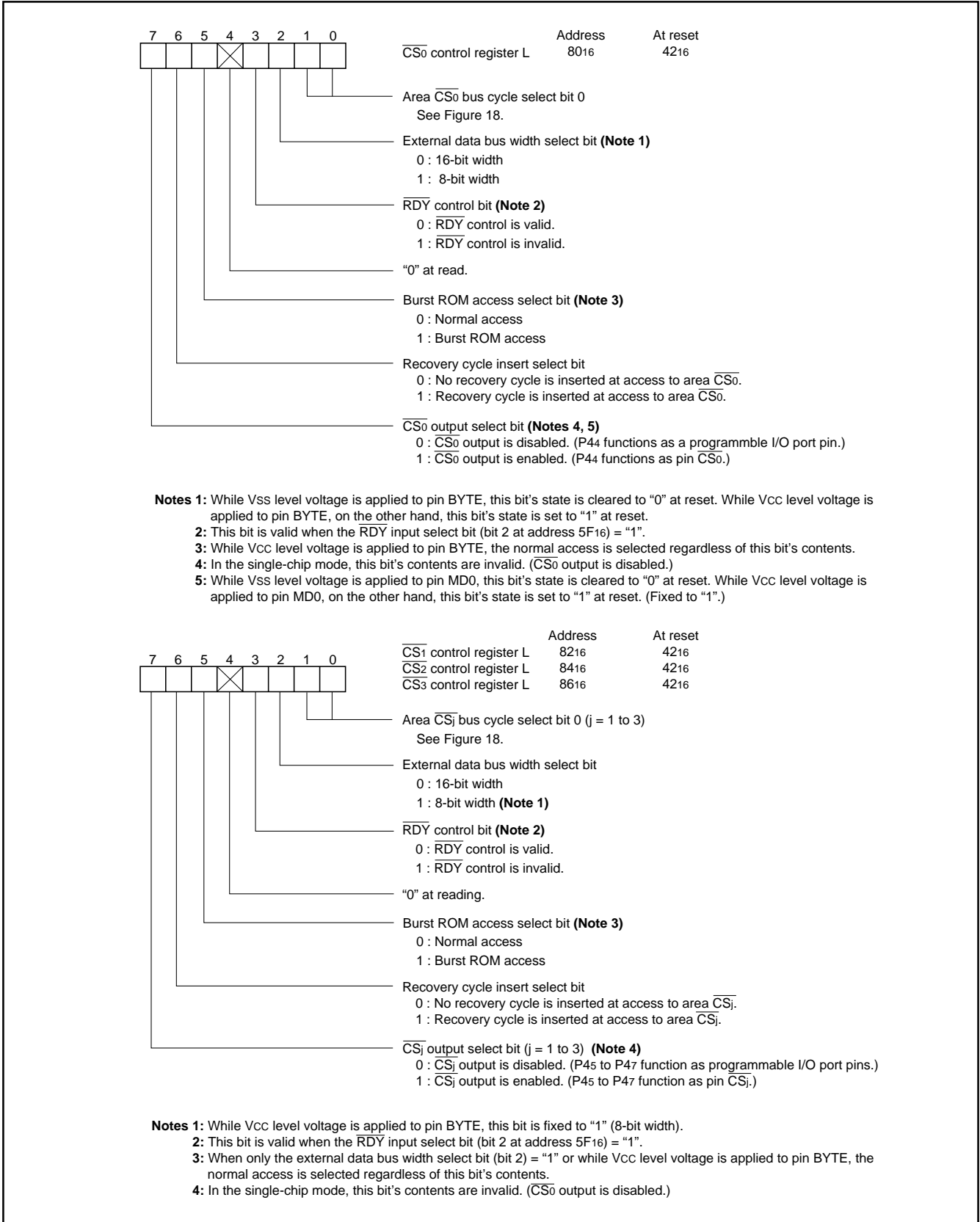

Fig. 28 Bit configuration of  $\overline{CS}_0/\overline{CS}_1/\overline{CS}_2/\overline{CS}_3$  control register Ls



# MITSUBISHI MICROCOMPUTERS

## M37902FCHP, M37902FGCHP, M37902FJCHP

SINGLE-CHIP 16-BIT CMOS MICROCOMPUTER

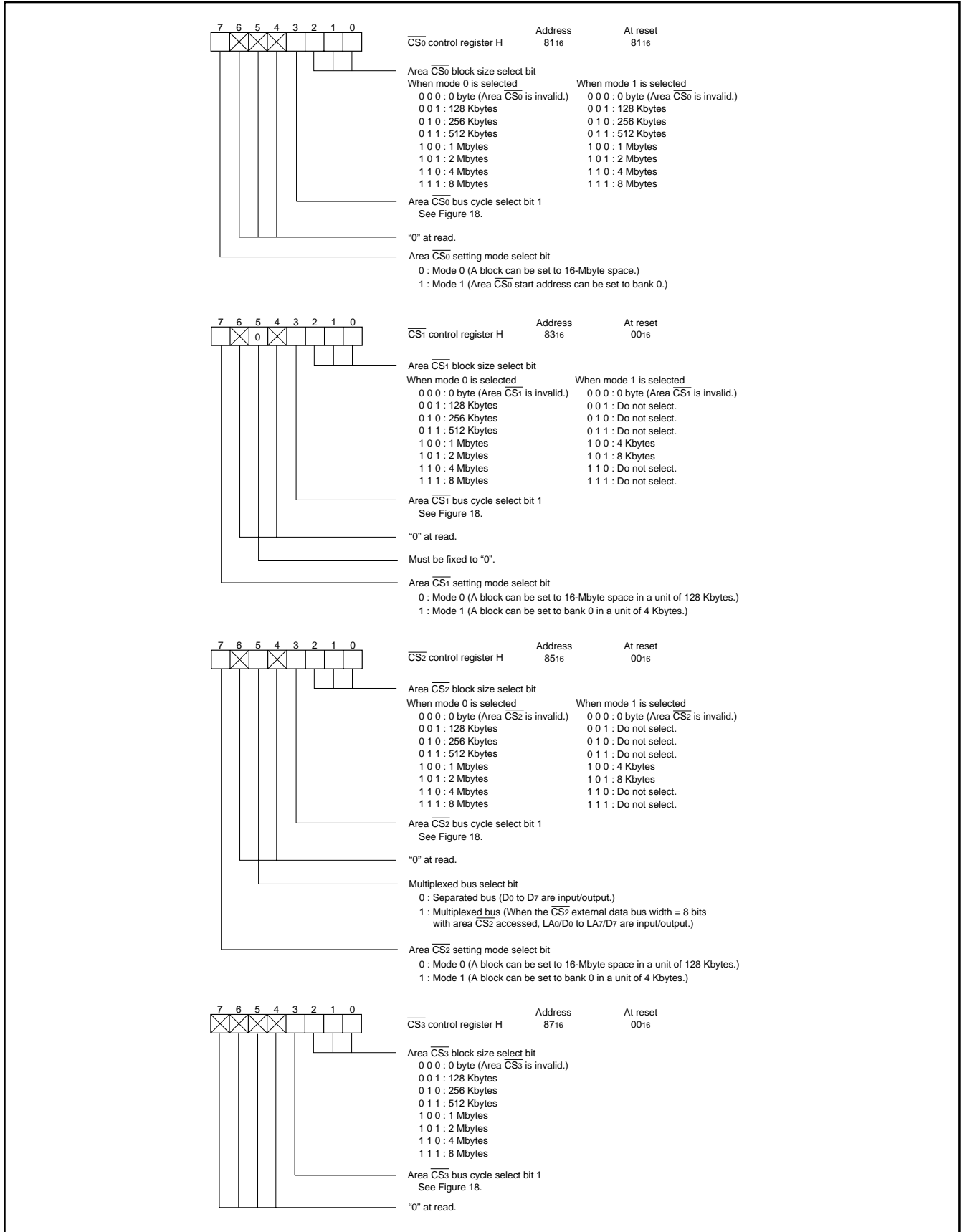
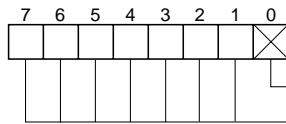

Fig. 29 Bit configuration of CS<sub>0</sub>/CS<sub>1</sub>/CS<sub>2</sub>/CS<sub>3</sub> control register Hs

MITSUBISHI MICROCOMPUTERS

# M37902FCHP, M37902FGHP, M37902FJCHP

SINGLE-CHIP 16-BIT CMOS MICROCOMPUTER



"0" at read.

When mode 0 is selected, these bits determine A<sub>16</sub> to A<sub>23</sub> of the area  $\overline{CS}_0$  start address.  
When mode 1 is selected, these bits determine A<sub>8</sub> to A<sub>15</sub> of the area  $\overline{CS}_0$  start address.

Any of the following values can be set to these bits: "10<sub>16</sub>", "20<sub>16</sub>", "40<sub>16</sub>", and "80<sub>16</sub>".  
(Bits 0 to 3 are always "0" at read.)

**Note:** Do not set a value other than "10<sub>16</sub>", "20<sub>16</sub>", "40<sub>16</sub>", and "80<sub>16</sub>". See Figure 31.

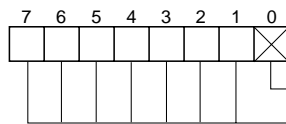

"0" at read.

When mode 0 is selected, these bits determine A<sub>16</sub> to A<sub>23</sub> of the area  $\overline{CS}_1/\overline{CS}_2$  start address.  
When mode 1 is selected, these bits determine A<sub>8</sub> to A<sub>15</sub> of the area  $\overline{CS}_1/\overline{CS}_2$  start address.

(Bit 0 is always "0" at read.)

**Note:** The start address setting depends on the block size, which has been selected by the area  $\overline{CS}_1/\overline{CS}_2$  block size select bits (bits 0 to 2 at address 83<sub>16</sub>, bits 0 to 2 at address 85<sub>16</sub>). See Figures 32 and 33.

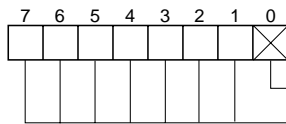

"0" at read.

These bits determine A<sub>16</sub> to A<sub>23</sub> of the area  $\overline{CS}_3$  start address.

(Bit 0 is always "0" at read.)

**Note:** The start address setting depends on the block size, which has been selected by the area  $\overline{CS}_3$  block size select bits (bits 0 to 2 at address 87<sub>16</sub>). See Figure 33.

Fig. 30 Bit configuration of area  $\overline{CS}_0/\overline{CS}_1/\overline{CS}_2/\overline{CS}_3$  start address registers

MITSUBISHI MICROCOMPUTERS  
**M37902FCCHP, M37902FGCHP, M37902FJCHP**

SINGLE-CHIP 16-BIT CMOS MICROCOMPUTER

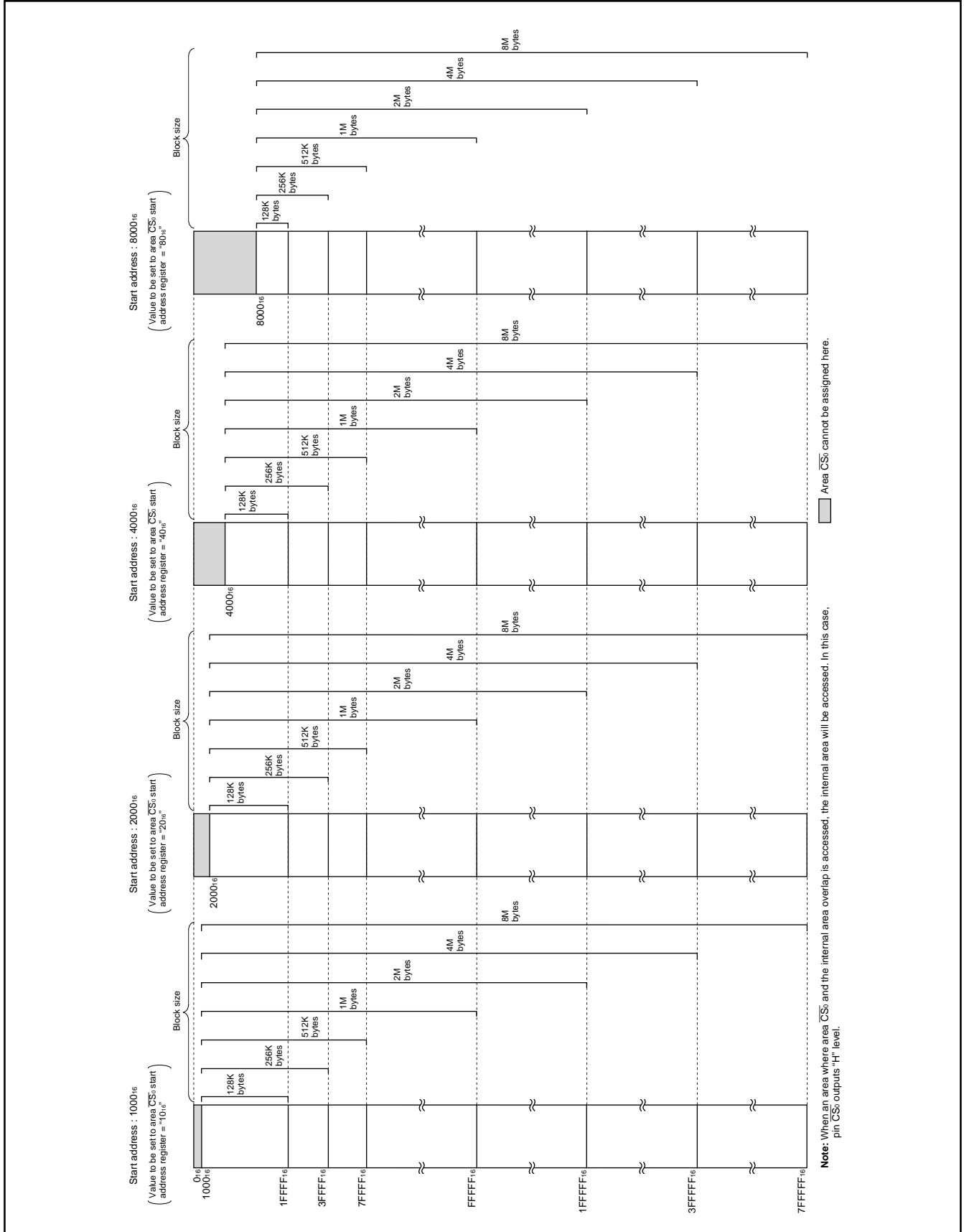

Fig. 31 Area CS<sub>0</sub> (mode 1)

**MITSUBISHI MICROCOMPUTERS**  
**M37902FCCHP, M37902FGCHP, M37902FJCHP**

SINGLE-CHIP 16-BIT CMOS MICROCOMPUTER

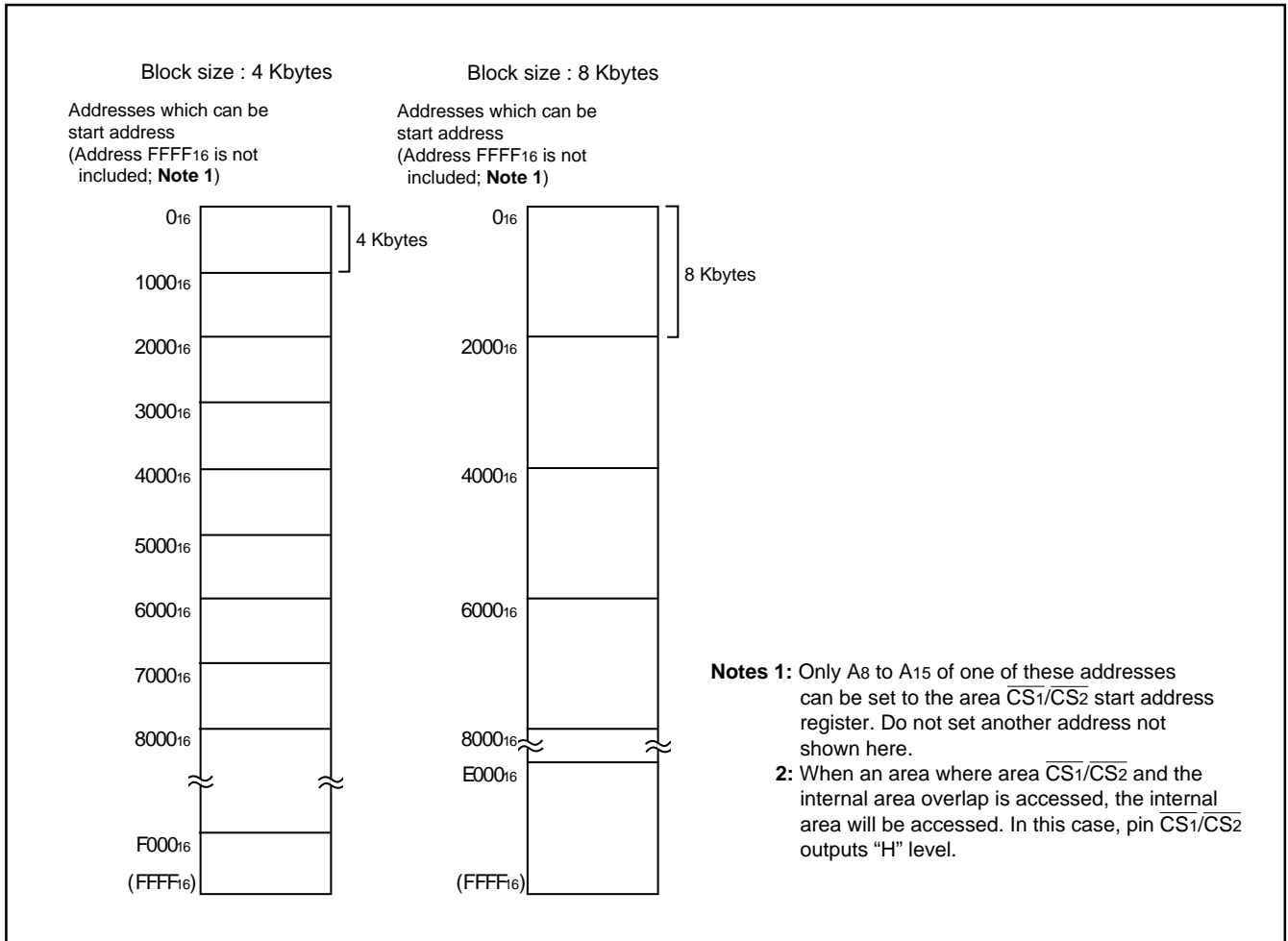

Fig. 32 Area  $\overline{CS}_1/\overline{CS}_2$  (mode 1)

# MITSUBISHI MICROCOMPUTERS

## M37902FCCHP, M37902FGCHP, M37902FJCHP

SINGLE-CHIP 16-BIT CMOS MICROCOMPUTER

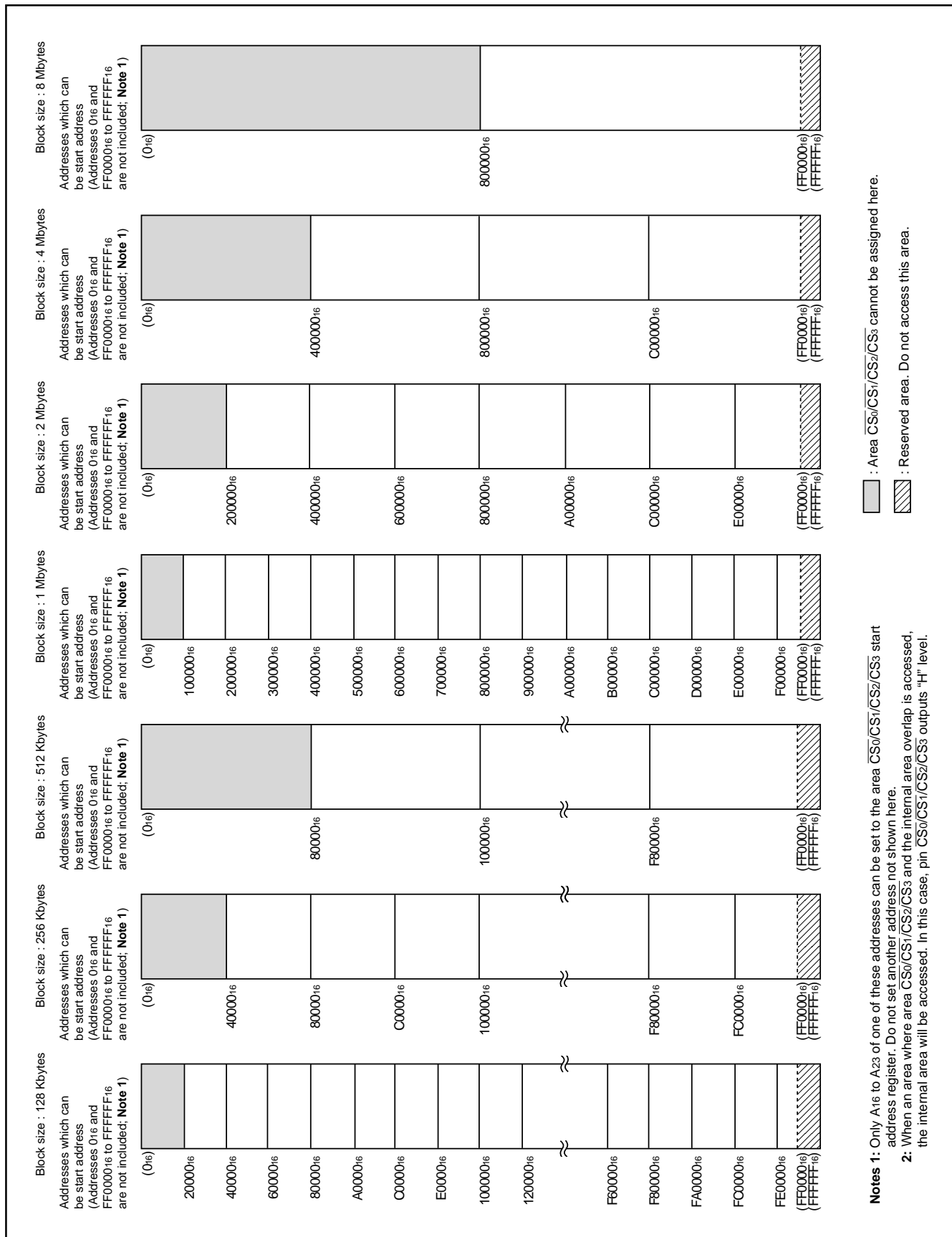

Fig. 33 Area  $\overline{CS_0}/\overline{CS_1}/\overline{CS_2}$  (mode 0) and area  $\overline{CS_3}$

MITSUBISHI MICROCOMPUTERS

# M37902FCCHP, M37902FGCHP, M37902FJCHP

SINGLE-CHIP 16-BIT CMOS MICROCOMPUTER

## INTERRUPTS

Table 8 shows the interrupt sources and the corresponding interrupt vector addresses. Reset is also handled as a type of interrupt in this section, too.

$\overline{DBC}$  and BRK instruction are interrupts used only for debugging. Therefore, do not use these interrupts.

Interrupts other than reset, watchdog timer, zero divide,  $\overline{NMI}$ , and address matching detection all have interrupt control registers. Table 9 shows the addresses of the interrupt control registers and Figure 35 shows the bit configuration of the interrupt control register.

The interrupt request bit is automatically cleared by the hardware during reset or when processing an interrupt. Also, interrupt request bits other than watchdog timer and  $\overline{NMI}$  can be cleared by software. An  $\overline{NMI}$  interrupt request is a non-maskable interrupt by an external input and is accepted at the falling edge of an input to pin  $\overline{NMI}$ . Also, pin  $\overline{NMI}$  has the pullup function. For more details, refer to the section on input/output pins.

An  $\overline{INT}_i$  ( $i = 0$  to  $4$ ) interrupt request is generated by an external input.

$\overline{INT}_0$  to  $\overline{INT}_2$  are external interrupts; whether to cause an interrupt at the input level (level sense) or at the edge (edge sense) can be selected with the level/edge select bit. Furthermore, the polarity of the interrupt input can be selected with the polarity select bit.

For  $\overline{INT}_3$  and  $\overline{INT}_4$ , the interrupt signal's polarity can be change by the polarity select bit. (This is valid only in the edge sense.)

By pins  $\overline{INT}_2$  to  $\overline{INT}_4$  select bits (bits 4 to 6 at address 94<sub>16</sub>; see Figure 40.), pin position of  $\overline{INT}_2$  to  $\overline{INT}_4$  can be changed.

When using the following pins as external interrupt input pins, clear the direction registers of the corresponding multiplexed ports to "0": pins P62/ $\overline{INT}_0$ , P63/ $\overline{INT}_1$ , P64(P77)/ $\overline{INT}_2$ , P80(P74)/ $\overline{INT}_3$ , and P84(P75)/ $\overline{INT}_4$ .

Furthermore, the  $\overline{INT}_3$  interrupt can function as the key input interrupt. For details, refer to the section on the key input interrupt.

When the external interrupt input read register (address 95<sub>16</sub>) is read out, the status of pins  $\overline{INT}_0$  to  $\overline{INT}_4$  and  $\overline{NMI}$  can directly be read.

Timer and UART interrupts are described in the respective section.

The priority of interrupts when multiple interrupt requests are caused simultaneously is partially fixed by hardware, but, it can also be adjusted by software as shown in Figure 36.

The hardware priority is fixed as the following:

reset >  $\overline{NMI}$  > watchdog timer > other interrupts

Table 8. Interrupt sources and interrupt vector addresses

Interrupts	Vector addresses
Address matching detection interrupt	00FFCA <sub>16</sub> 00FFCB <sub>16</sub>
$\overline{INT}_4$ external interrupt	00FFD0 <sub>16</sub> 00FFD1 <sub>16</sub>
$\overline{INT}_3$ external interrupt	00FFD2 <sub>16</sub> 00FFD3 <sub>16</sub>
A-D conversion	00FFD4 <sub>16</sub> 00FFD5 <sub>16</sub>
UART1 transmit	00FFD6 <sub>16</sub> 00FFD7 <sub>16</sub>
UART1 receive	00FFD8 <sub>16</sub> 00FFD9 <sub>16</sub>
UART0 transmit	00FFDA <sub>16</sub> 00FFDB <sub>16</sub>
UART0 receive	00FFDC <sub>16</sub> 00FFDD <sub>16</sub>
Timer B2	00FFDE <sub>16</sub> 00FFDF <sub>16</sub>
Timer B1	00FFE0 <sub>16</sub> 00FFE1 <sub>16</sub>
Timer B0	00FFE2 <sub>16</sub> 00FFE3 <sub>16</sub>
Timer A4	00FFE4 <sub>16</sub> 00FFE5 <sub>16</sub>
Timer A3	00FFE6 <sub>16</sub> 00FFE7 <sub>16</sub>
Timer A2	00FFE8 <sub>16</sub> 00FFE9 <sub>16</sub>
Timer A1	00FFEA <sub>16</sub> 00FFEB <sub>16</sub>
Timer A0	00FFEC <sub>16</sub> 00FFED <sub>16</sub>
$\overline{INT}_2$ external interrupt	00FFEE <sub>16</sub> 00FFEF <sub>16</sub>
$\overline{INT}_1$ external interrupt	00FFF0 <sub>16</sub> 00FFF1 <sub>16</sub>
$\overline{INT}_0$ external interrupt	00FFF2 <sub>16</sub> 00FFF3 <sub>16</sub>
$\overline{NMI}$ external interrupt	00FFF4 <sub>16</sub> 00FFF5 <sub>16</sub>
Watchdog timer	00FFF6 <sub>16</sub> 00FFF7 <sub>16</sub>
$\overline{DBC}$ (Do not select.)	00FFF8 <sub>16</sub> 00FFF9 <sub>16</sub>
Break instruction (Do not select.)	00FFFA <sub>16</sub> 00FFFB <sub>16</sub>
Zero divide	00FFFC <sub>16</sub> 00FFFD <sub>16</sub>
Reset	00FFFE <sub>16</sub> 00FFFF <sub>16</sub>

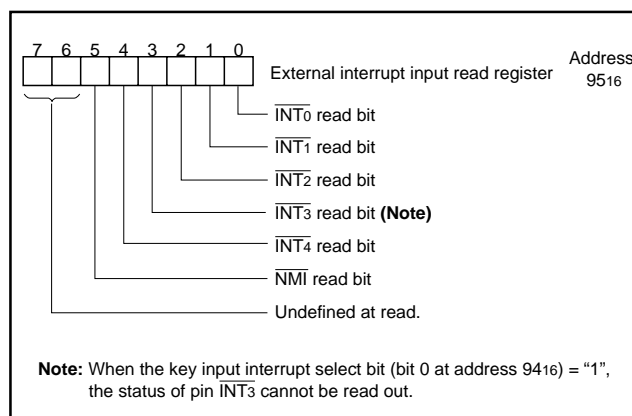
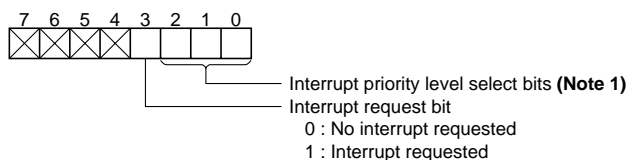

Fig. 34 Bit configuration of external interrupt input read register

MITSUBISHI MICROCOMPUTERS

# M37902FCCHP, M37902FGCHP, M37902FJCHP

SINGLE-CHIP 16-BIT CMOS MICROCOMPUTER



Interrupt control register bit configuration for A-D converter, UART0, UART1, timer A0 to timer A4, and timer B0 to timer B2.

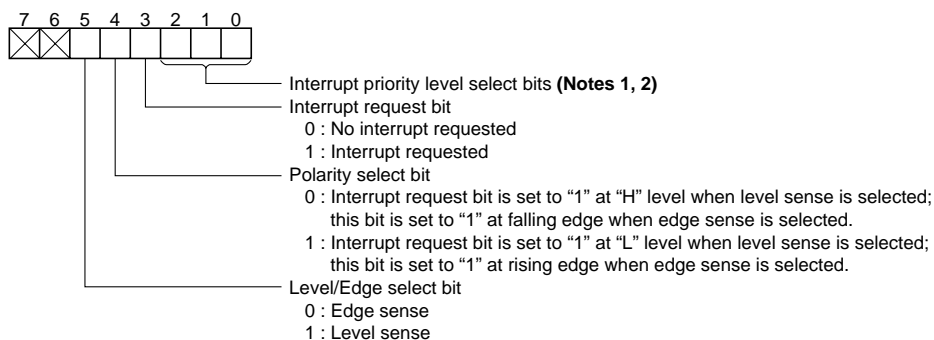

Interrupt control register bit configuration for  $\overline{INT_0}$ –  $\overline{INT_2}$

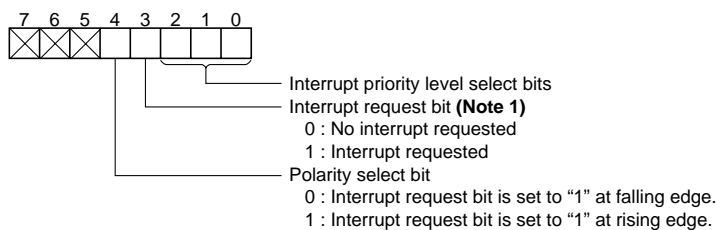

Interrupt control register bit configuration for  $\overline{INT_3}$  and  $\overline{INT_4}$

- Notes 1:** Use the **MOVM (MOVMB)** instruction or the **STA (STAB, STAD)** instruction for writing to this bit.  
**2:** Interrupt request bits of  $\overline{INT_0}$  to  $\overline{INT_2}$  are invalid when the level sense is selected.

Fig. 35 Bit configuration of interrupt control register

# MITSUBISHI MICROCOMPUTERS

## M37902FCCHP, M37902FGCHP, M37902FJCHP

SINGLE-CHIP 16-BIT CMOS MICROCOMPUTER

Table 9. Addresses of interrupt control registers

Interrupt control registers	Addresses
INT $\bar{3}$ interrupt control register	00006E <sub>16</sub>
INT $\bar{4}$ interrupt control register	00006F <sub>16</sub>
A-D interrupt control register	000070 <sub>16</sub>
UART0 transmit interrupt control register	000071 <sub>16</sub>
UART0 receive interrupt control register	000072 <sub>16</sub>
UART1 transmit interrupt control register	000073 <sub>16</sub>
UART1 receive interrupt control register	000074 <sub>16</sub>
Timer A0 interrupt control register	000075 <sub>16</sub>
Timer A1 interrupt control register	000076 <sub>16</sub>
Timer A2 interrupt control register	000077 <sub>16</sub>
Timer A3 interrupt control register	000078 <sub>16</sub>
Timer A4 interrupt control register	000079 <sub>16</sub>
Timer B0 interrupt control register	00007A <sub>16</sub>
Timer B1 interrupt control register	00007B <sub>16</sub>
Timer B2 interrupt control register	00007C <sub>16</sub>
INT $\bar{0}$ interrupt control register	00007D <sub>16</sub>
INT $\bar{1}$ interrupt control register	00007E <sub>16</sub>
INT $\bar{2}$ interrupt control register	00007F <sub>16</sub>

Interrupts caused by the address matching detection and when dividing by zero are software interrupts and are not included in Figure 36.

Other interrupts previously mentioned are A-D converter, UART, etc. interrupts. The priority of these interrupts can be changed by changing the priority level in the corresponding interrupt control register by software.

Figure 37 shows a diagram of the interrupt priority detection circuit. When an interrupt is caused, each interrupt device compares its own priority with the priority from above and if its own priority is higher, then it sends the priority below and requests the interrupt. If the priorities are the same, the one above has priority.

This comparison is repeated to select the interrupt with the highest priority among the interrupts that are being requested. Finally the selected interrupt is compared with the processor interrupt priority level (IPL) contained in the processor status register (PS) and the request is accepted if it is higher than IPL and the interrupt disable flag I is "0". The request is not accepted if flag I is "1". The reset, NMI, and watchdog timer interrupts are not affected by the interrupt disable flag I.

When an interrupt is accepted, the contents of the processor status register (PS) is saved to the stack and the interrupt disable flag I is set to "1".

Furthermore, the interrupt request bit of the accepted interrupt is cleared to "0" and the processor interrupt priority level (IPL) in the processor status register (PS) is replaced by the priority level of the accepted interrupt.

Therefore, multi-level priority interrupts are possible by resetting the interrupt disable flag I to "0" and enable further interrupts.

For reset, watchdog timer, zero divide, NMI, and address match detection interrupts, which do not have an interrupt control register, the processor interrupt level (IPL) is set as shown in Table 10.

The interrupt request bit and the interrupt priority level of each interrupt source are sampled and latched at each operation code fetch cycle while  $f_{sys}$  is "H". However, no sampling pulse is generated until the cycles whose number is selected by software has passed, even if the next operation code fetch cycle is generated. The detection of an interrupt which has the highest priority is performed during that time.

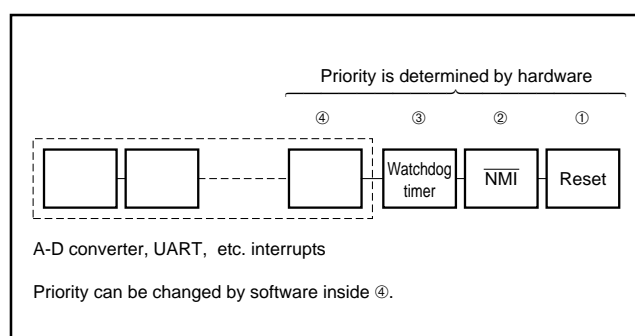

Fig. 36 Interrupt priority

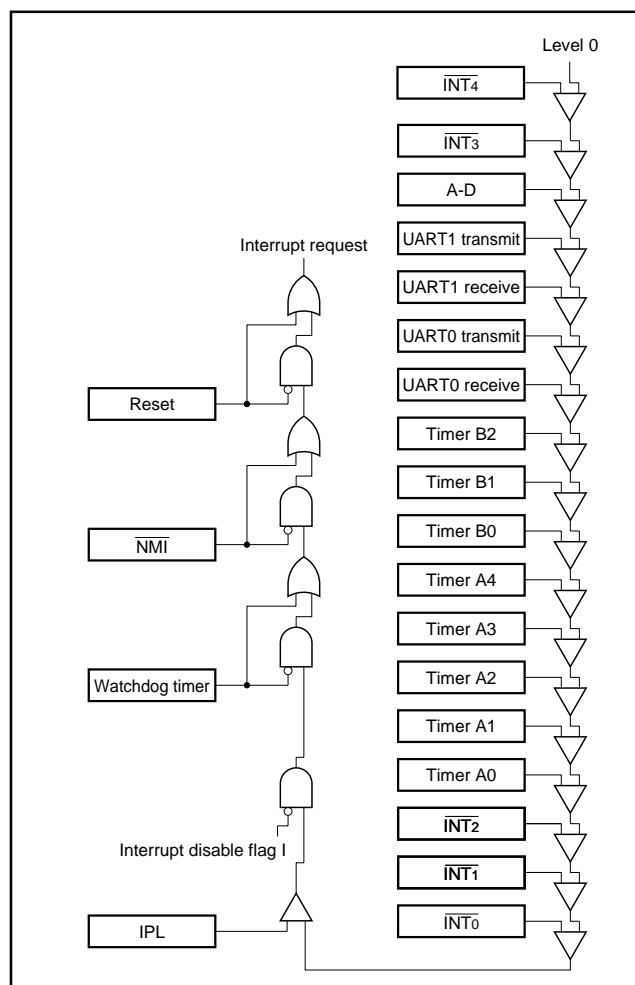

Fig. 37 Interrupt priority detection



# MITSUBISHI MICROCOMPUTERS

## M37902FCCHP, M37902FGCHP, M37902FJCHP

SINGLE-CHIP 16-BIT CMOS MICROCOMPUTER

As shown in Figure 38, there are three different interrupt priority detection time from which one is selected by software. After the selected time has elapsed, the highest priority is determined and is processed after the currently executing instruction has been completed.

The time is selected with bits 4 and 5 of the processor mode register 0 (address 5E16) shown in Figure 24. Table 11 shows the relationship between these bits and the number of cycles. After a reset, the processor mode register 0 is initialized to "0016." Therefore, the longest time is automatically set, however, the shortest time must be selected by software.

Table 10. Value loaded in processor interrupt level (IPL) during an interrupt

Interrupt types	Setting value
Reset	0
Watchdog timer	7
NMI	7
Zero divide	Not change value of IPL.
Address matching detection	Not change value of IPL.

Table 11. Relationship between interrupt priority detection time select bit and number of cycles

Priority detection time select bit		Number of cycles (Note)
Bit 5	Bit 4	
0	0	7 cycles of $f_{sys}$
0	1	4 cycles of $f_{sys}$
1	0	2 cycles of $f_{sys}$

**Note:** For system clock  $f_{sys}$ , refer to the section on the clock generating circuit.

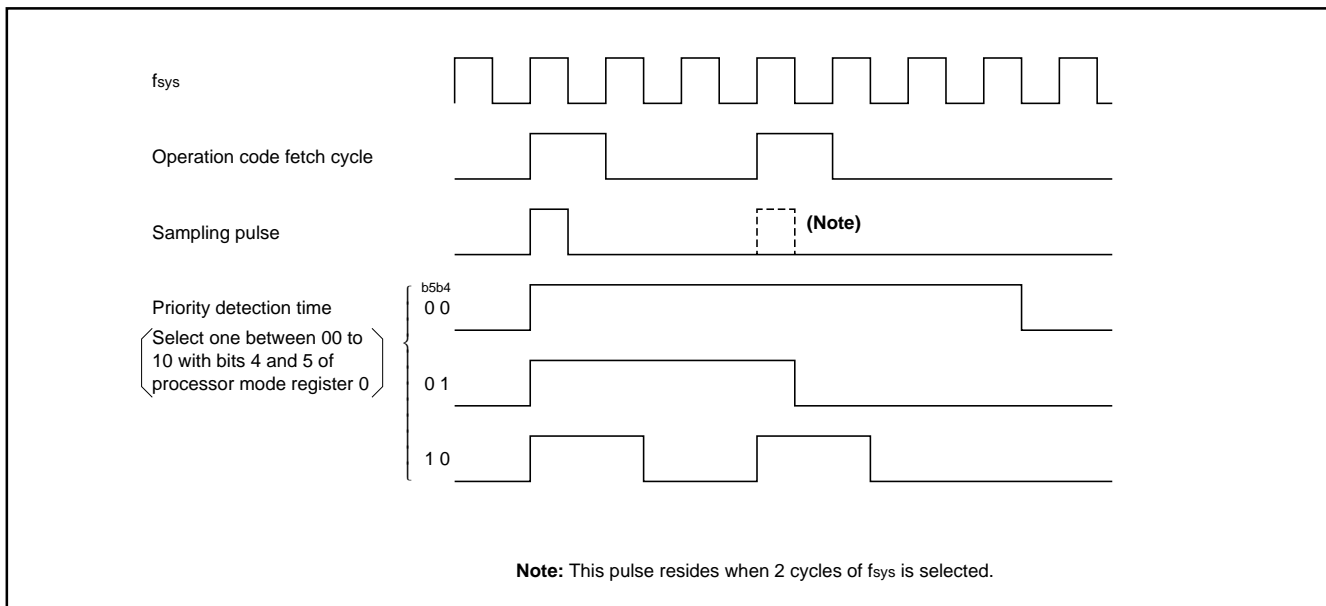

Fig. 38 Interrupt priority detection time

MITSUBISHI MICROCOMPUTERS

# M37902FCCHP, M37902FGCHP, M37902FJCHP

SINGLE-CHIP 16-BIT CMOS MICROCOMPUTER

## Key Input Interrupt

The  $\overline{INT3}$  interrupt can function as the key input interrupt by setting bits 1 to 3 of the external interrupt input control register (address 9416). The key input interrupt uses inputs  $\overline{KI0}$  to  $\overline{KI3}$ . Figure 39 shows the block diagram of the  $\overline{INT3}$ /key input interrupt input circuit, and Figure 40 shows the bit configuration of the external interrupt input control register.

When bit 0 of the external interrupt input control register (key input interrupt select bit) = "0", a signal from pin  $\overline{INT3}$  is connected to the  $\overline{INT3}$  interrupt control circuit, and  $\overline{INT3}$  external interrupt is normally performed. When bit 0 = "1", signals from pins  $\overline{KI0}$  to  $\overline{KI3}$ , which correspond to ports P54 to P57 pins, are inverted, and then, the logical sum of these signals is connected to the  $\overline{INT3}$  interrupt control regis-

ter. In this case, the external interrupt which uses pins  $\overline{KI0}$  to  $\overline{KI3}$  is performed.

Bits 2 and 3 of the external interrupt input control register are the key input interrupt pin select bits. By setting these bits, the combination of key input interrupt pins can be selected. The interrupt vector addresses and interrupt control register of the key input interrupt are common to those of the  $\overline{INT3}$  interrupt. Additionally, pullup resistors (transistors) can be added to pins  $\overline{KI0}$  to  $\overline{KI4}$  by setting as follows:

- Set bit 1 of the external interrupt input control register to "1".
- Next, select the key input interrupt pins by bits 2 and 3 of the external interrupt input control register.
- Then, clear the contents of the port direction register which corresponds to the selected pins to "0".

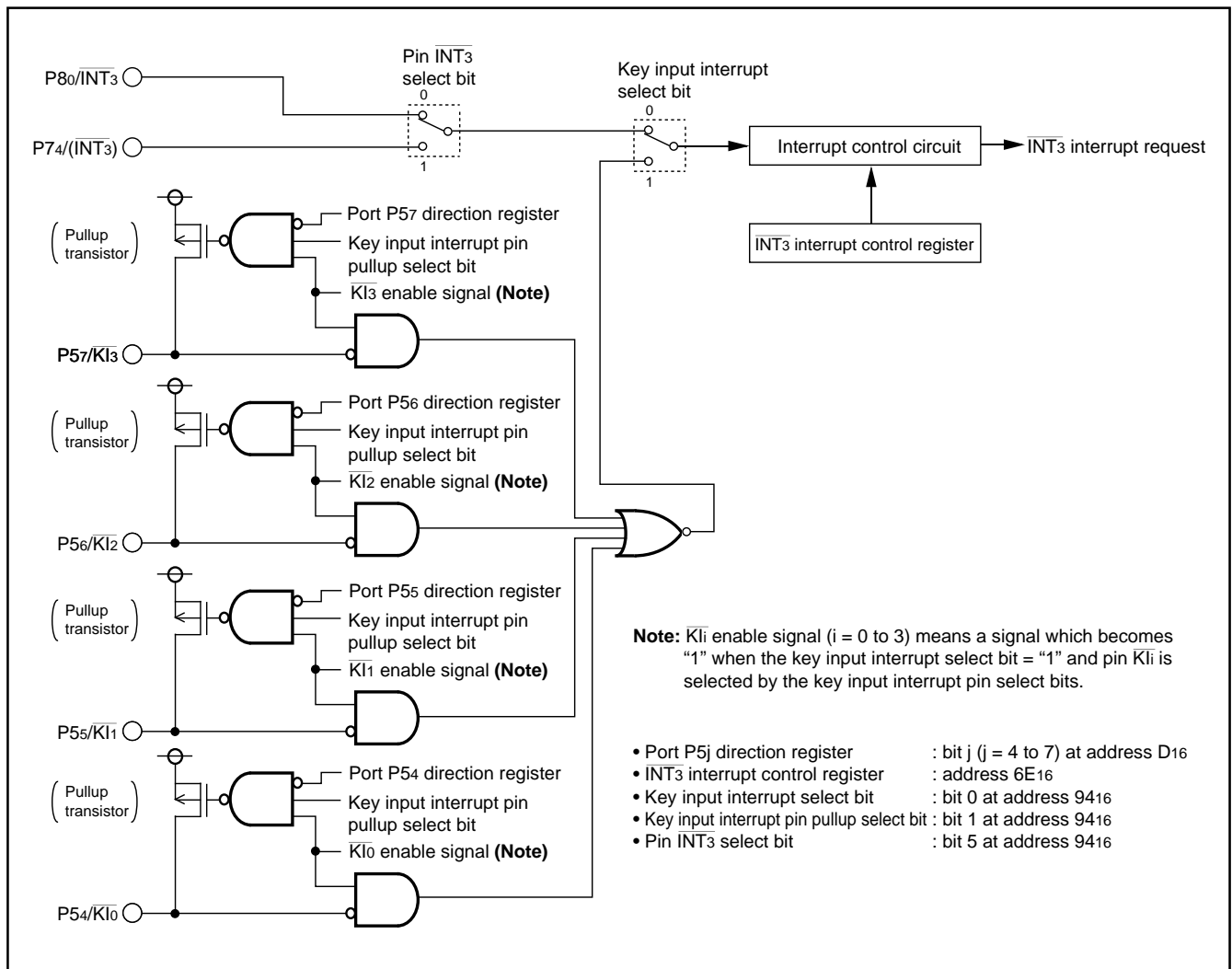

Fig. 39 Block diagram of  $\overline{INT3}$ /key input interrupt input circuit

MITSUBISHI MICROCOMPUTERS

# M37902FCCHP, M37902FGCHP, M37902FJCHP

SINGLE-CHIP 16-BIT CMOS MICROCOMPUTER

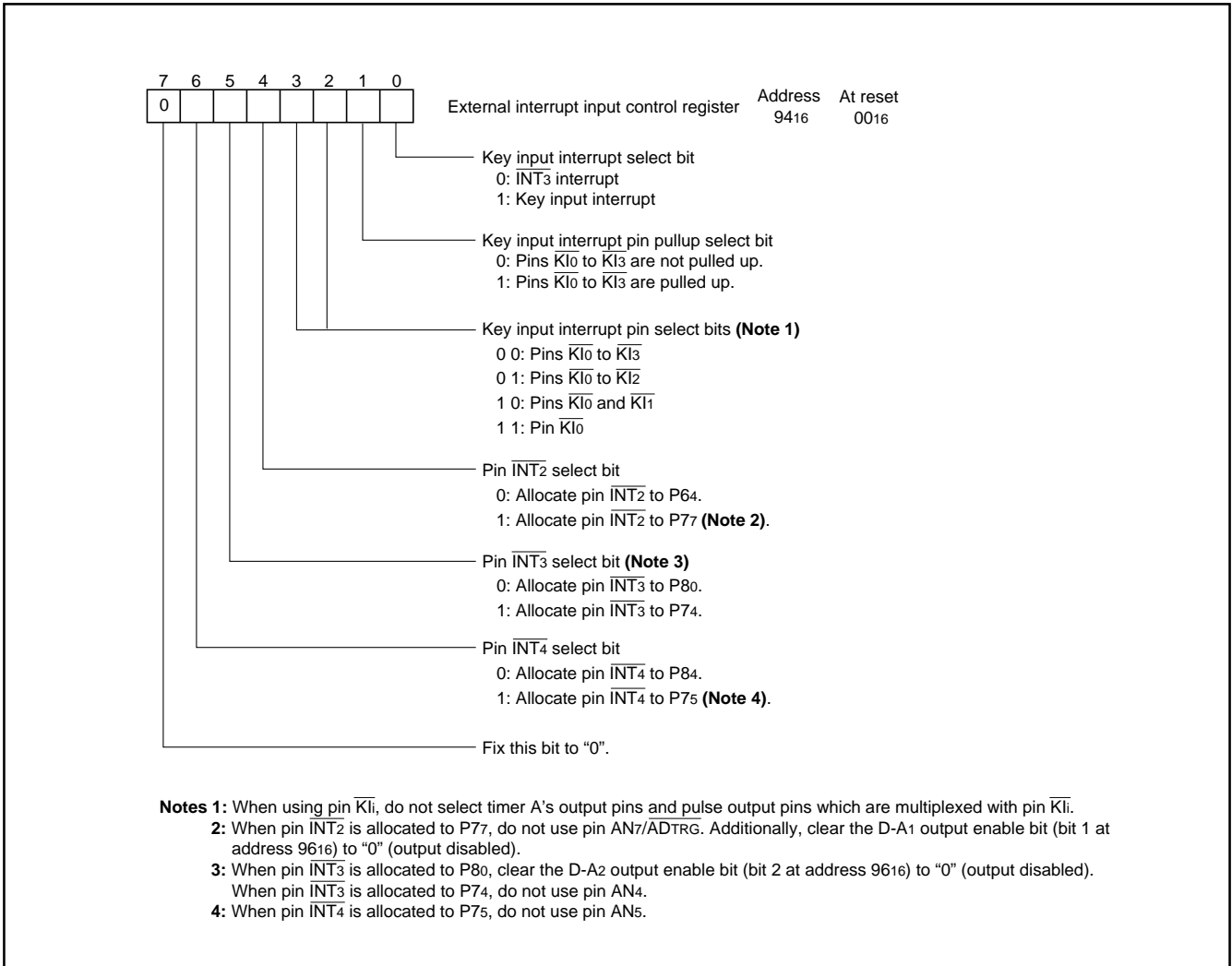

Fig. 40 Bit configuration of external interrupt input control register

MITSUBISHI MICROCOMPUTERS

# M37902FCCHP, M37902FGCHP, M37902FJCHP

SINGLE-CHIP 16-BIT CMOS MICROCOMPUTER

## TIMER

There are eight 16-bit timers. They are divided by type into timer A(5) and timer B(3).

The timer I/O pins are multiplexed with I/O pins for port P5 and P6. To use these pins as timer input pins, the port direction register bit corresponding to the pin must be cleared to "0" to specify input mode.

## TIMER A

Figure 41 shows a block diagram of timer A.

Timer A has four modes: timer mode, event counter mode, one-shot pulse mode, and pulse width modulation mode. The mode is selected with bits 0 and 1 of the timer Ai mode register (i = 0 to 4). Each of these modes is described below.

Figure 42 shows the bit configuration of the timer A clock division select register. Timers A0 to A4 use the count source which has been

selected by bits 0 and 1 of this register.

### (1) Timer mode [00]

Figure 43 shows the bit configuration of the timer Ai mode register during timer mode. Bits 0, 1 and 5 of the timer Ai mode register must be "0" in timer mode. The timer A's count source is selected by bits 6 and 7 of the timer Ai mode register and the contents of the timer A clock division select register. (See Table 12.)

The counting of the selected clock starts when the count start bit is "1" and stops when it is "0".

Figure 44 shows the bit configuration of the count start bit. The counter is decremented, an interrupt is caused and the interrupt request bit in the timer Ai interrupt control register is set when the contents becomes 0000<sub>16</sub>. At the same time, the contents of the reload register is transferred to the counter and count is continued.

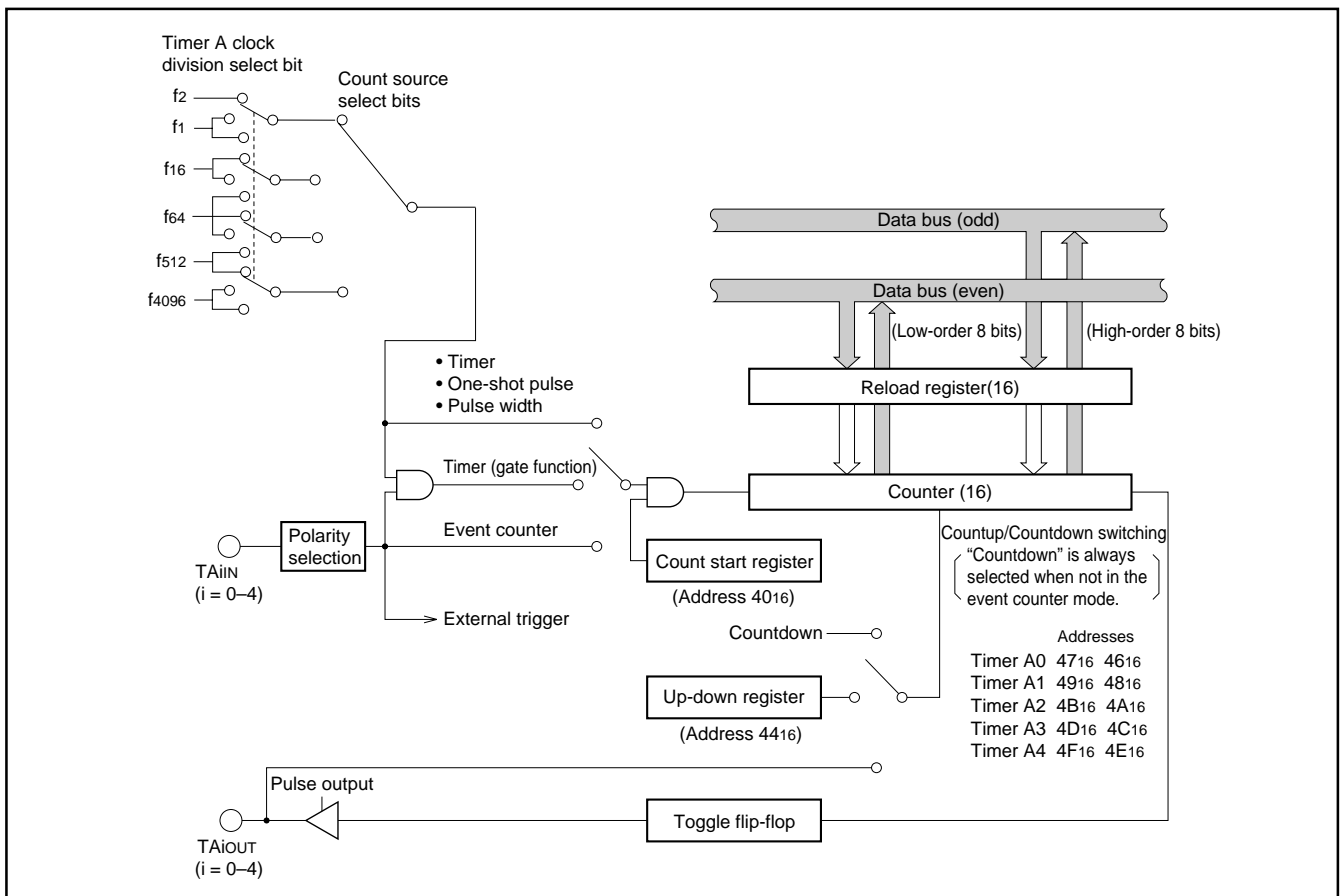

Fig. 41 Block diagram of timer A

MITSUBISHI MICROCOMPUTERS

# M37902FCCHP, M37902FGCHP, M37902FJCHP

SINGLE-CHIP 16-BIT CMOS MICROCOMPUTER

When bit 2 of the timer Ai mode register is "1", the output is generated from TAIOUT pin. The output is toggled each time the contents of the counter reaches to 0000<sub>16</sub>. When the contents of the count start bit is "0", "L" is output from TAIOUT pin.

When bit 2 is "0", TAIOUT can be used as a normal port pin. When bit 4 is "0", TAIIN can be used as a normal port pin.

When bit 4 is "1", counting is performed only while the input signal from the TAIIN pin is "H" or "L" as shown in Figure 45. Therefore, this can be used to measure the pulse width of the TAIIN input signal. Whether to count while the input signal is "H" or while it is "L" is determined by bit 3. If bit 3 is "1", counting is performed while the TAIIN pin input signal is "H" and if bit 3 is "0", counting is performed while it is "L".

Note that, the duration of "H" or "L" on the TAIIN pin must be 2 or more cycles of the timer count source.

When data is written to timer Ai register with timer Ai halted, the same data is also written to the reload register and the counter.

When data is written to timer Ai which is busy, the data is written to the reload register, but not to the counter. The new data is reloaded from the reload register to the counter at the next reload time and counting continues. The contents of the counter can be read at any time.

When the value set in the timer Ai register is n, the timer frequency division ratio is 1/(n+1).

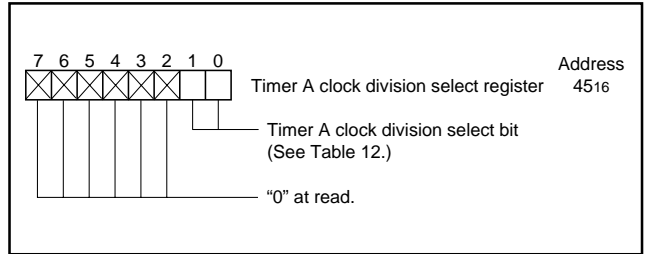

Fig. 42 Bit configuration of timer A clock division select register

Table 12. Relationship between timer A clock division select bits, clock source select bits, and count source

Clock source select bits (bits 7 and 6 at addresses 56 <sub>16</sub> to 5A <sub>16</sub> )	Timer A clock division select bits (bits 1 and 0 at address 45 <sub>16</sub> )			
	00	01	10	11
0 0	f <sub>2</sub>	f <sub>1</sub>	f <sub>1</sub>	Do not select.
0 1	f <sub>16</sub>	f <sub>16</sub>	f <sub>64</sub>	
1 0	f <sub>64</sub>	f <sub>64</sub>	f <sub>512</sub>	
1 1	f <sub>512</sub>	f <sub>4096</sub>	f <sub>4096</sub>	

**Note:** Timers A0 to A4 use the same clock, which is selected by the timer A clock division select bits.

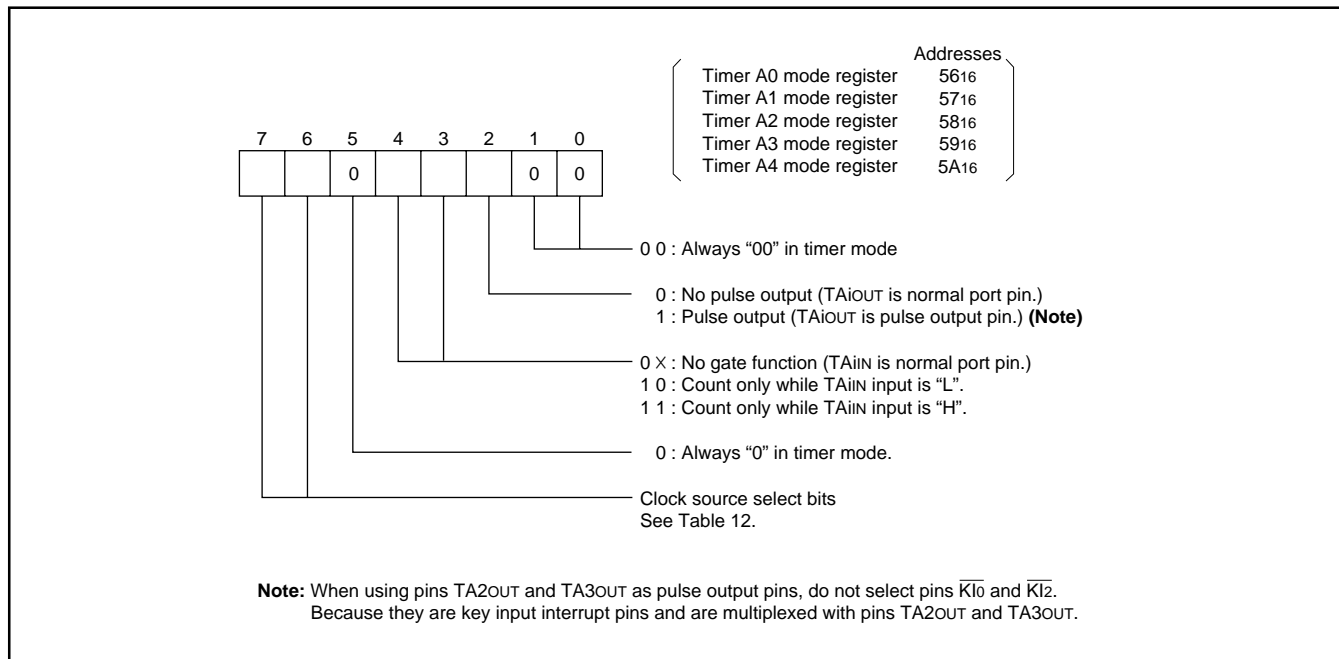

Fig. 43 Bit configuration of timer Ai mode register during timer mode

MITSUBISHI MICROCOMPUTERS

# M37902FCCHP, M37902FGCHP, M37902FJCHP

SINGLE-CHIP 16-BIT CMOS MICROCOMPUTER

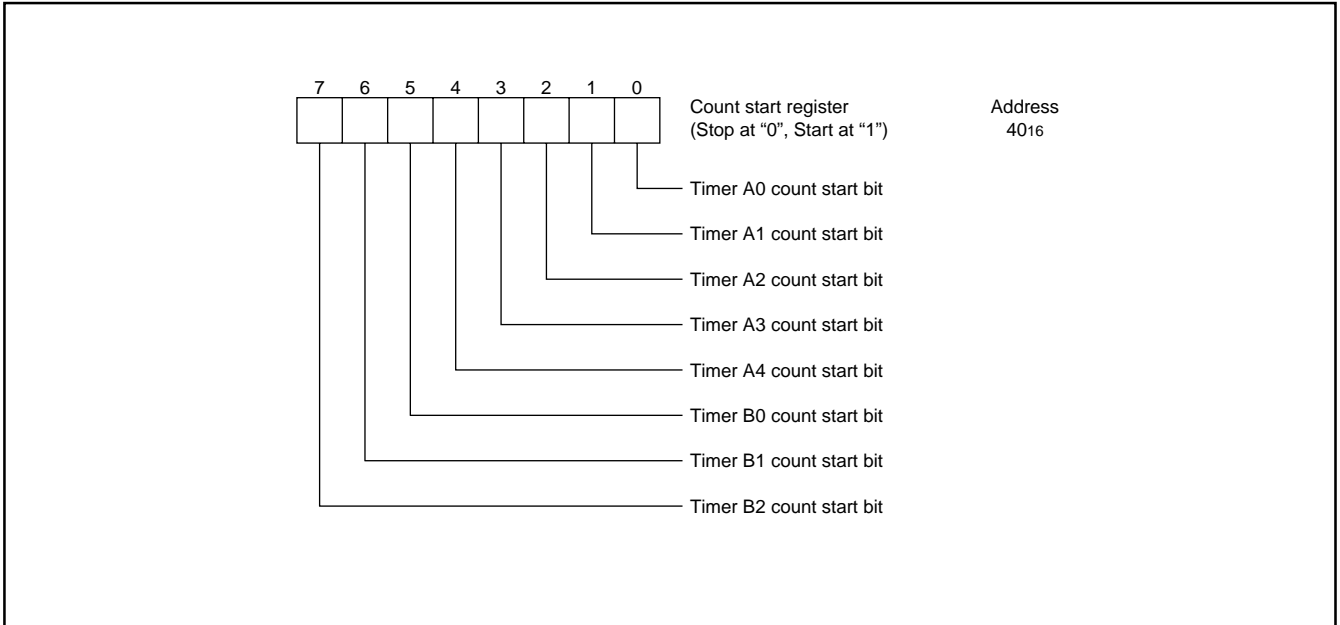

Fig. 44 Bit configuration of count start register

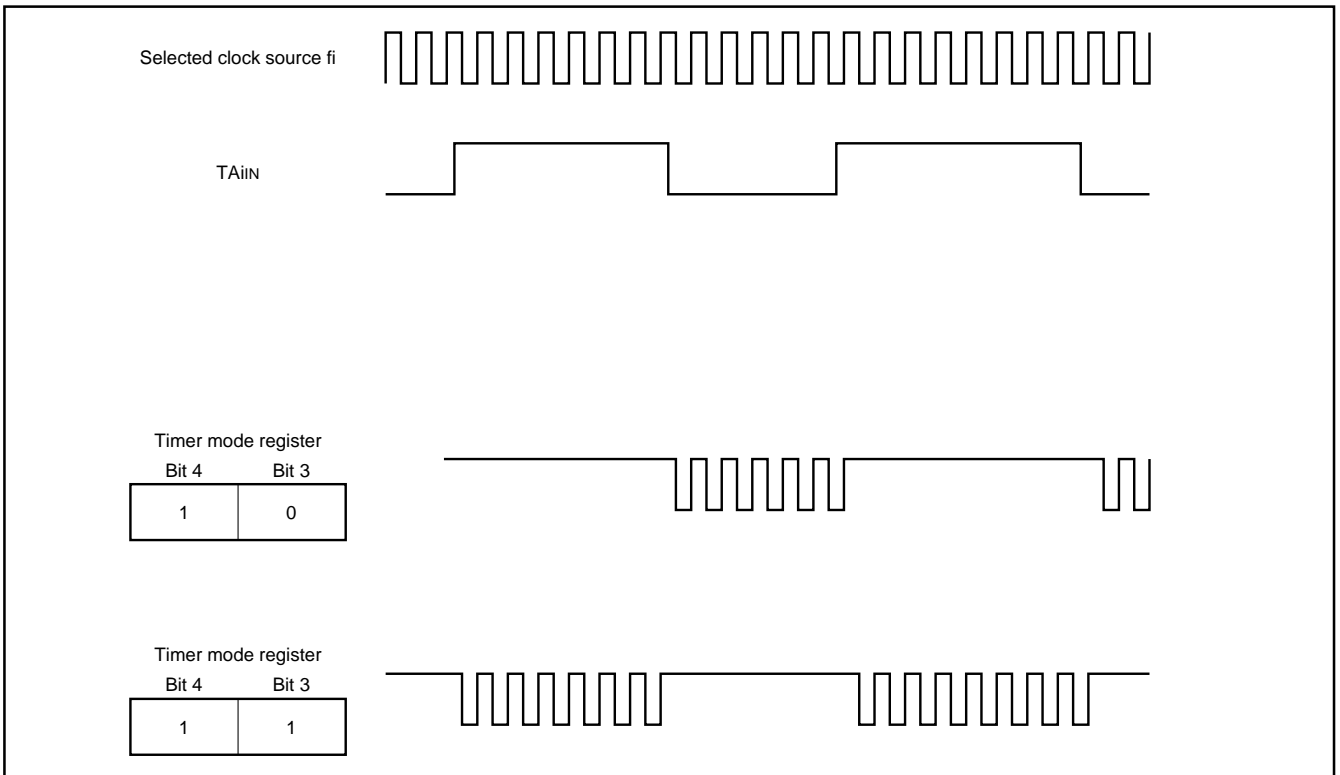

Fig. 45 Count waveform when gate function is available

MITSUBISHI MICROCOMPUTERS

# M37902FCCHP, M37902FGCHP, M37902FJCHP

SINGLE-CHIP 16-BIT CMOS MICROCOMPUTER

## (2) Event counter mode [01]

Figure 46 shows the bit configuration of the timer Ai mode register during event counter mode. In event counter mode, bit 0 of the timer Ai mode register must be "1" and bits 1 and 5 must be "0".

The input signal from the TAIiN pin is counted when the count start bit shown in Figure 44 is "1" and counting is stopped when it is "0". Count is performed at the fall of the input signal when bit 3 is "0" and at the rise of the signal when it is "1".

In event counter mode, whether to increment or decrement the count can be selected with the up-down bit or the input signal from the TAIOUT pin.

When bit 4 of the timer Ai mode register is "0", the up-down bit is used to determine whether to increment or decrement the count (decrement when the bit is "0" and increment when it is "1"). Figure 47 shows the bit configuration of the up-down register.

When bit 4 of the timer Ai mode register is "1", the input signal from the TAIOUT pin is used to determine whether to increment or decrement the count. However, note that bit 2 must be "0" if bit 4 is "1." It is because if bit 2 is "1", TAIOUT pin becomes an output pin to output pulses.

The count is decremented when the input signal from the TAIOUT pin is "L" and incremented when it is "H". Determine the level of the input signal from the TAIOUT pin before a valid edge is input to the TAIiN pin.

An interrupt request signal is generated and the interrupt request bit in the timer Ai interrupt control register is set when the counter reaches 0000<sub>16</sub> (decrement count) or FFFF<sub>16</sub> (increment count). At the same time, the contents of the reload register is transferred to the counter and the count is continued.

When bit 2 is "1," each time the counter reaches 0000<sub>16</sub> (decrement count) or FFFF<sub>16</sub>(increment count), the waveform's polarity is reversed and is output from TAIOUT pin.

If bit 2 is "0", TAIOUT pin can be used as a normal port pin.

However, if bit 4 is "1" and the TAIOUT pin is used as an output pin, the output from the pin changes the count direction. Therefore, bit 4 must be "0" unless the output from the TAIOUT pin is to be used to select the count direction.

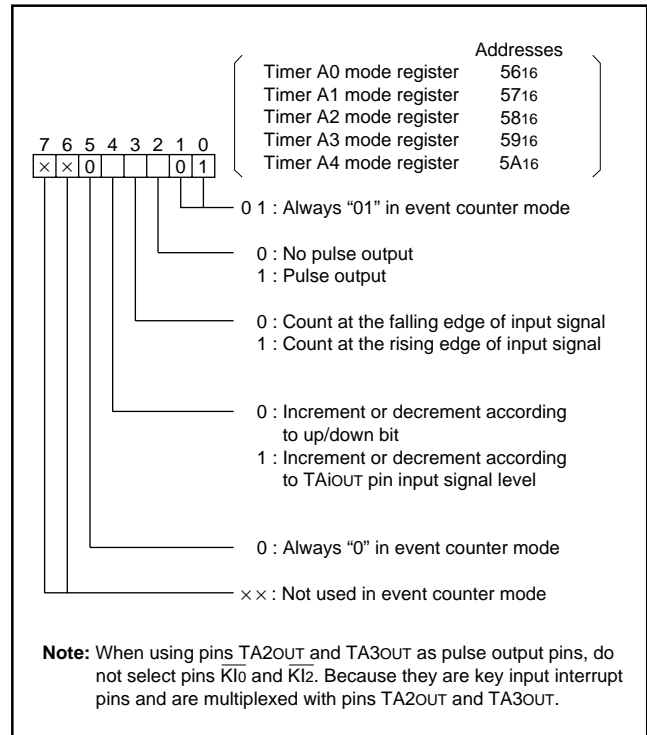

Fig. 46 Bit configuration of timer Ai mode register during event counter mode

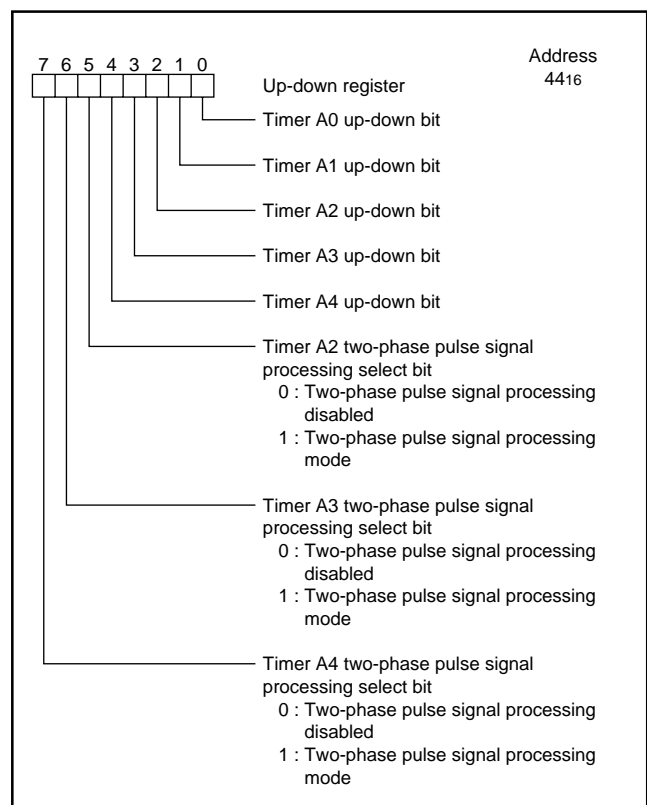

Fig. 47 Bit configuration of up-down register

MITSUBISHI MICROCOMPUTERS

# M37902FCCHP, M37902FGCHP, M37902FJCHP

SINGLE-CHIP 16-BIT CMOS MICROCOMPUTER

Data write and data read are performed in the same way as for timer mode. That is, when data is written to timer  $A_i$  halted, it is also written to the reload register and the counter. When data is written to timer  $A_i$  which is busy, the data is written to the reload register, but not to the counter. The counter is reloaded with new data from the reload register at the next reload time. The counter can be read at any time.

In event counter mode, whether to increment or decrement the counter can also be determined by supplying two kinds of pulses of which phases differ by  $90^\circ$  to timer A2, A3, or A4. There are two types of two-phase pulse processing operations. One uses timers A2 and A3, and the other uses timer A4. In both processing operations, two pulses described above are input to the  $TA_{jOUT}$  ( $j = 2$  to 4) pin and  $TA_{jIN}$  pin respectively.

When timers A2 and A3 are used, as shown in Figure 48, the count is incremented when a rising edge is input to the  $TA_{kIN}$  pin after the level of  $TA_{kOUT}$  ( $k=2, 3$ ) pin changes from "L" to "H", and when the falling edge is input, the count is decremented.

For timer A4, as shown in Figure 49, when a phase-related pulse with a rising edge input to the  $TA_{4IN}$  pin is input after the level of  $TA_{4OUT}$  pin changes from "L" to "H", the count is incremented at the respective rising edge and falling edge of the  $TA_{4OUT}$  pin and  $TA_{4IN}$  pin.

When a phase-related pulse with a falling edge input to the  $TA_{4OUT}$  pin is input after the level of  $TA_{4IN}$  pin changes from "H" to "L", the count is decremented at the respective rising edge and falling edge of the  $TA_{4IN}$  pin and  $TA_{4OUT}$  pin. When performing this two-phase pulse signal processing, timer  $A_j$  mode register bit 0 and bit 4 must be set to "1" and bits 1, 2, 3, and 5 must be "0". Bits 6 and 7 are ig-

nored. (See Figure 50.) Note that bits 5, 6, and 7 of the up-down register (address  $4416$ ) are the two-phase pulse signal processing select bits for timers A2, A3 and A4 respectively. Each timer operates in normal event counter mode when the corresponding bit is "0" and performs two-phase pulse signal processing when it is "1".

Count is started by setting the count start bit to "1". Data write and read are performed in the same way as for normal event counter mode. Note that the direction register of the input port must be set to input mode because two kinds of pulse signals, described above, are input. Also, there can be no pulse output in this mode.

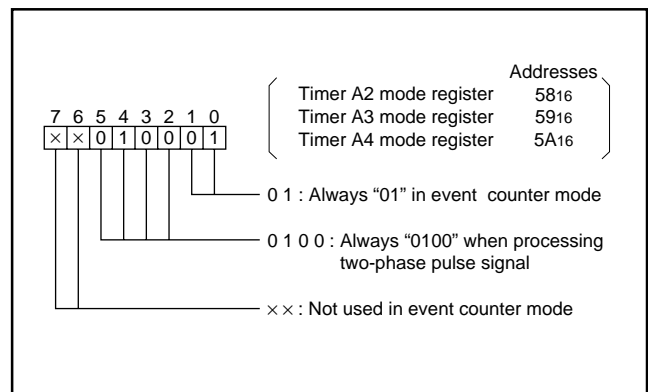

Fig. 50 Bit configuration of timer  $A_j$  mode register when performing two-phase pulse signal processing in event counter mode

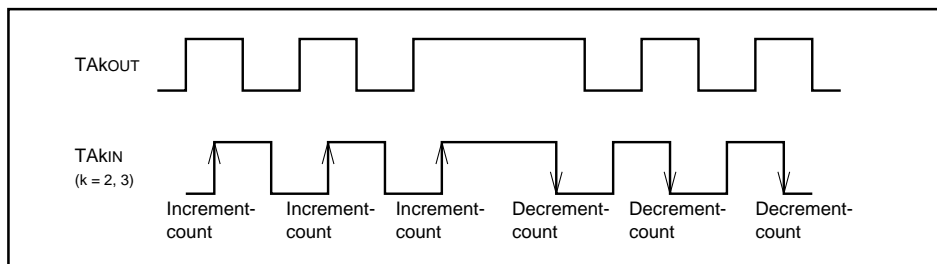

Fig. 48 Two-phase pulse processing operation of timers A2 and A3

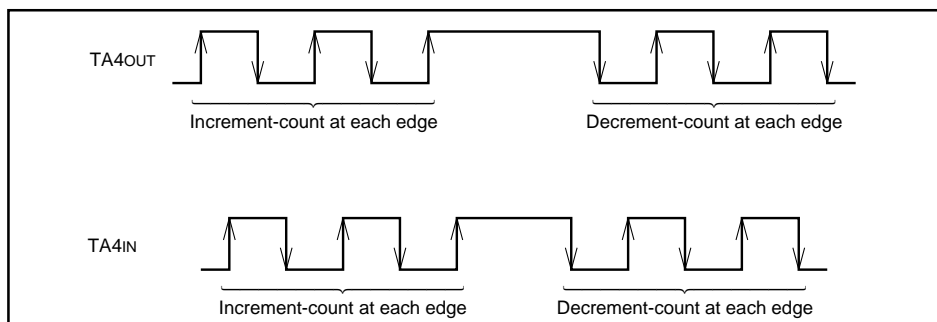

Fig. 49 Two-phase pulse processing operation of timer A4



MITSUBISHI MICROCOMPUTERS

# M37902FCCHP, M37902FGCHP, M37902FJCHP

SINGLE-CHIP 16-BIT CMOS MICROCOMPUTER

### (3) One-shot pulse mode [10]

Figure 51 shows the bit configuration of the timer Ai mode register during one-shot pulse mode. In one-shot pulse mode, bit 0 and bit 5 must be "0" and bit 1 and bit 2 must be "1".

The trigger is enabled when the count start bit is "1". The trigger can be generated by software or it can be input from the TAIIN pin. Software trigger is selected when bit 4 is "0" and the input signal from the TAIIN pin is used as the trigger when it is "1".

Bit 3 is used to determine whether to trigger at the fall of the trigger signal or at the rise. The trigger is at the fall of the trigger signal when bit 3 is "0" and at the rise of the trigger signal when it is "1".

Software trigger is generated by setting "1" to a bit in the one-shot start register. Each bit corresponds to each timer.

Figure 52 shows the bit configuration of the one-shot start register.

As shown in Figure 53, when a trigger signal is received, the counter counts the clock selected by bits 6 and 7 and the contents of the timer A clock division select register. (Set Table 12.)

If the contents of the counter is not 0000<sub>16</sub>, the TAIOUT pin goes "H" when a trigger signal is received. The count direction is decrement. When the counter reaches 0001<sub>16</sub>, the TAIOUT pin goes "L" and count is stopped. The contents of the reload register is transferred to the counter. At the same time, an interrupt request signal is generated and the interrupt request bit in the timer Ai interrupt control register is set. This is repeated each time a trigger signal is received. The output pulse width is

$$\frac{1}{\text{pulse frequency of the selected clock}} \times (\text{counter's value at the time of trigger}).$$

If the count start flag is "0", TAIOUT goes "L". Therefore, the value corresponding to the desired pulse width must be written to timer Ai before setting the timer Ai count start bit.

As shown in Figure 54, a trigger signal can be received before the operation for the previous trigger signal is completed. In this case, the contents of the reload register is transferred to the counter by the trigger and then that value is decremented.

Except when retriggering while operating, the contents of the reload register are not transferred to the counter by triggering.

When retriggering, there must be at least one timer count source cycle before a new trigger can be issued.

Data write is performed in the same way as for timer mode.

When data is written in timer Ai halted, it is also written to the reload register and the counter.

When data is written to timer Ai which is busy, the data is written to the reload register, but not to the counter. The counter is reloaded with new data from the reload register at the next reload time.

Undefined data is read when timer Ai is read.

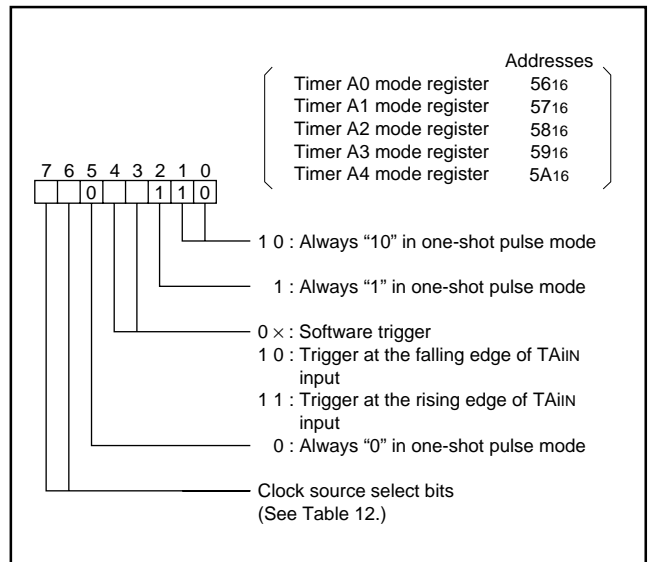

Fig. 51 Bit configuration of timer Ai mode register during one-shot pulse mode

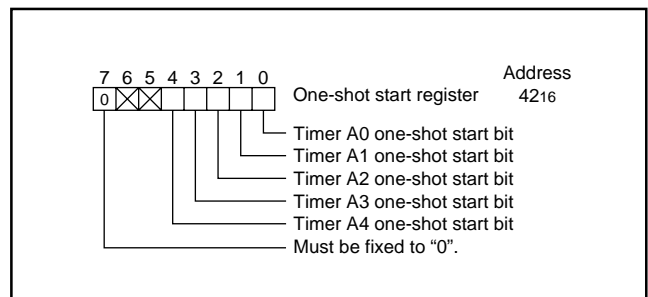

Fig. 52 Bit configuration of one-shot start register

MITSUBISHI MICROCOMPUTERS  
**M37902FCCHP, M37902FGCHP, M37902FJCHP**

SINGLE-CHIP 16-BIT CMOS MICROCOMPUTER

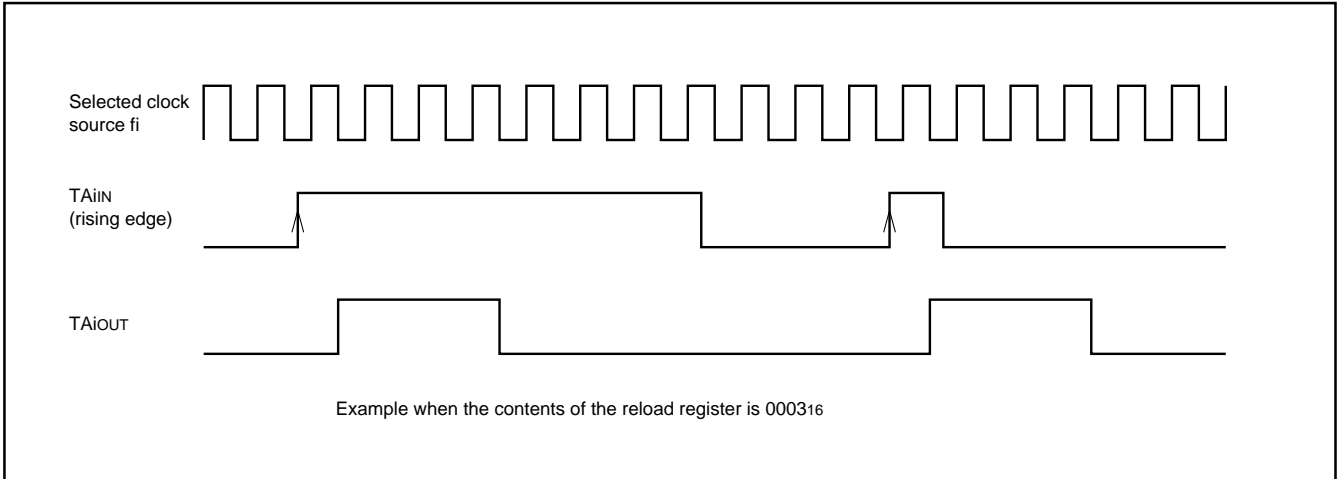

Fig. 53 Pulse output example when external rising edge is selected

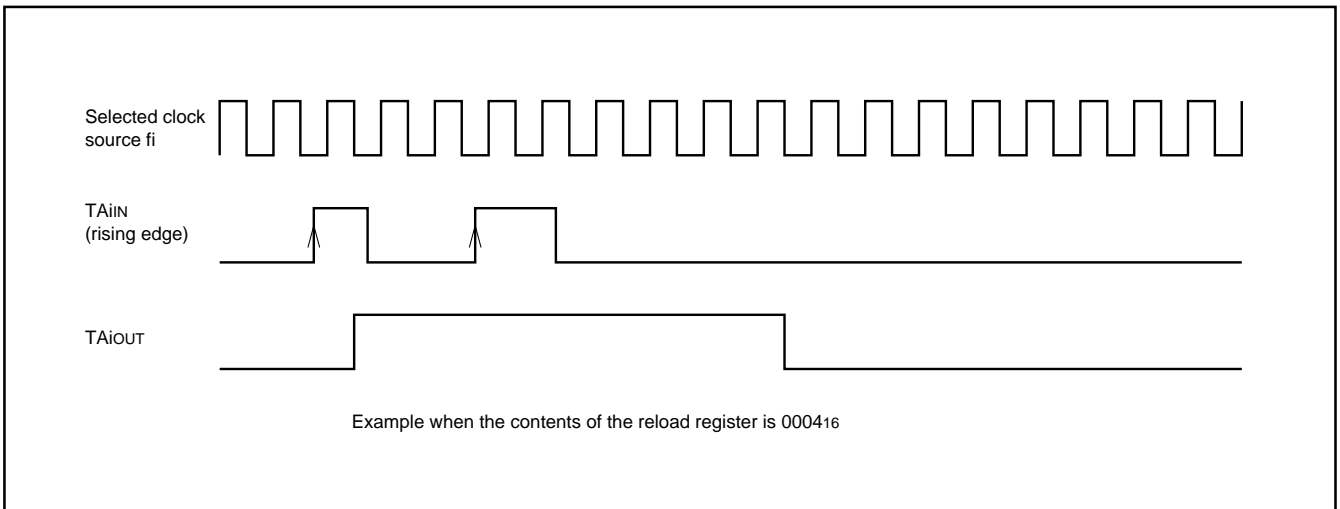

Fig. 54 Example when trigger is re-issued during pulse output

MITSUBISHI MICROCOMPUTERS

# M37902FCCHP, M37902FGCHP, M37902FJCHP

SINGLE-CHIP 16-BIT CMOS MICROCOMPUTER

## (4) Pulse width modulation mode [11]

Figure 55 shows the bit configuration of the timer Ai mode register during pulse width modulation mode. In pulse width modulation mode, bits 0, 1, and 2 must be set to "1".

Bit 5 is used to determine whether to perform 16-bit length pulse width modulator or 8-bit length pulse width modulator. 16-bit length pulse width modulator is selected when bit 5 is "0" and 8-bit length pulse width modulator is selected when it is "1". The 16-bit length pulse width modulator is described first.

The pulse width modulator can be started with a software trigger or with an input signal from a TAIIN pin (external trigger).

The software trigger mode is selected when bit 4 is "0".

Pulse width modulator is started and a pulse is output from TAIOUT when the count start bit is set to "1".

The external trigger mode is selected when bit 4 is "1".

Pulse width modulation starts when a trigger signal is input from the TAIIN pin when the count start bit is "1". Whether to trigger at the fall or rise of the trigger signal is determined by bit 3. The trigger is at the fall of the trigger signal when bit 3 is "0" and at the rise when it is "1". When data is written to timer Ai with the pulse width modulator halted, it is written to the reload register and the counter.

Then when the count start bit is set to "1" and a software trigger or an external trigger is issued to start modulation, the waveform shown in Figure 56 is output continuously.

Once modulation is started, triggers are not accepted. If the value in the reload register is m, the duration "H" of pulse is

$$\frac{1}{\text{selected clock frequency}} \times m$$

and the output pulse period is

$$\frac{1}{\text{selected clock frequency}} \times (2^{16} - 1).$$

An interrupt request signal is generated and the interrupt request bit in the timer Ai interrupt control register is set at each fall of the output pulse.

The width of the output pulse is changed by updating timer data. The update can be performed at any time. The output pulse width is changed at the rise of the pulse after data is written to the timer.

The contents of the reload register are transferred to the counter just before the rise of the next pulse so that the pulse width is changed from the next output pulse.

Undefined data is read when timer Ai is read.

The 8-bit length pulse width modulator is described next.

The 8-bit length pulse width modulator is selected when the timer Ai mode register bit 5 is "1".

The reload register and the counter are both divided into 8-bit halves.

The low-order 8 bits function as a prescaler and the high-order 8 bits function as the 8-bit length pulse width modulator. The prescaler counts the clock selected by bits 6, 7, and the contents of the timer A clock division select register. (See Table 12.) A pulse is generated when the counter reaches 0000<sub>16</sub> as shown in Figure 57. At the same time, the contents of the reload register is transferred to the counter and count is continued.

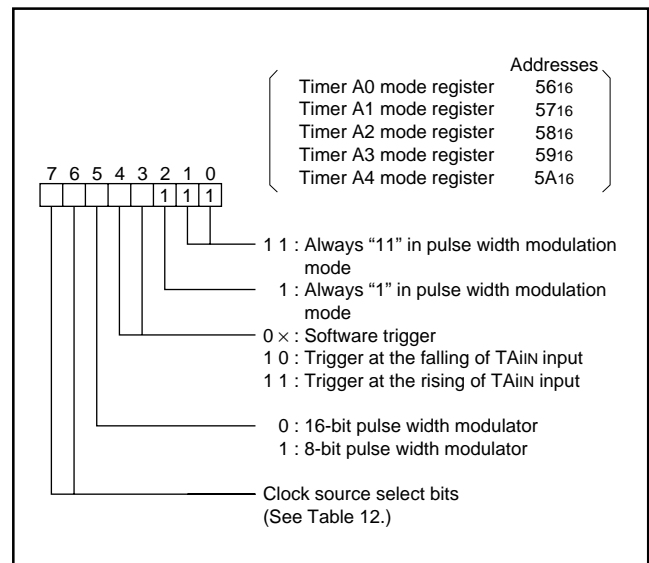

Fig. 55 Bit configuration of timer Ai mode register during pulse width modulation mode

MITSUBISHI MICROCOMPUTERS

# M37902FCCHP, M37902FGCHP, M37902FJCHP

SINGLE-CHIP 16-BIT CMOS MICROCOMPUTER

Therefore, if the low-order 8 bits of the reload register are  $n$ , the period of the generated pulse is

$$\frac{1}{\text{selected clock frequency}} \times (n+1).$$

The high-order 8 bits function as an 8-bit length pulse width modulator using this pulse as input. The operation is the same as for 16-bit length pulse width modulator except that the length is 8 bits. If the

high-order 8 bits of the reload register are  $m$ , the duration "H" of pulse is

$$\frac{1}{\text{selected clock frequency}} \times (n+1) \times m.$$

And the output pulse period is

$$\frac{1}{\text{selected clock frequency}} \times (n+1) \times (2^8-1).$$

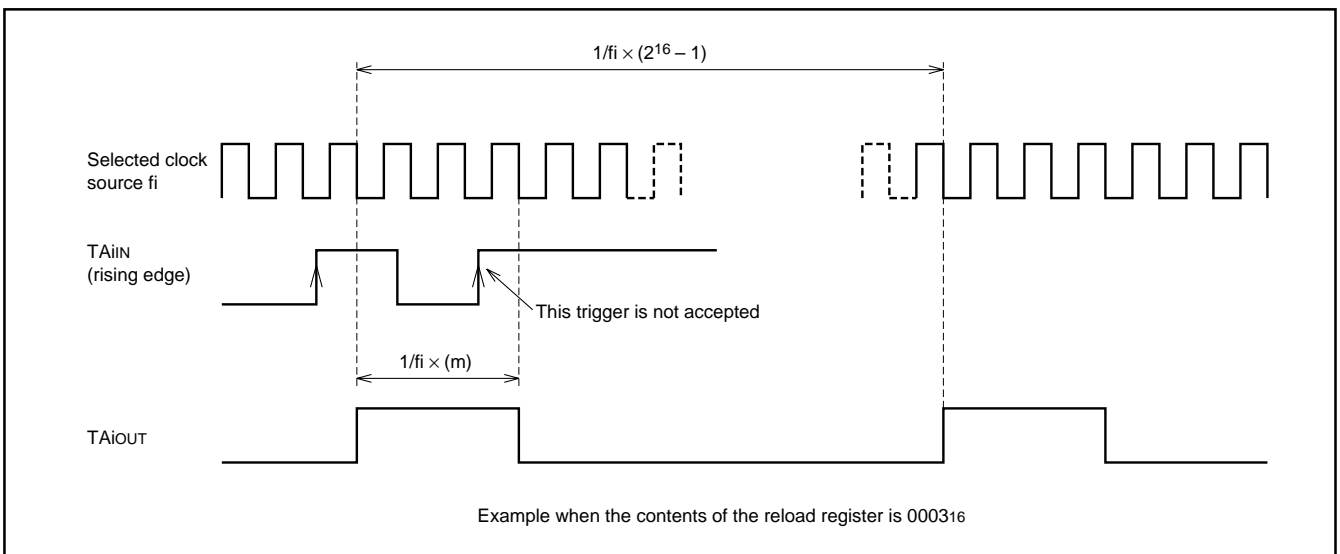

Fig. 56 16-bit length pulse width modulator output pulse example

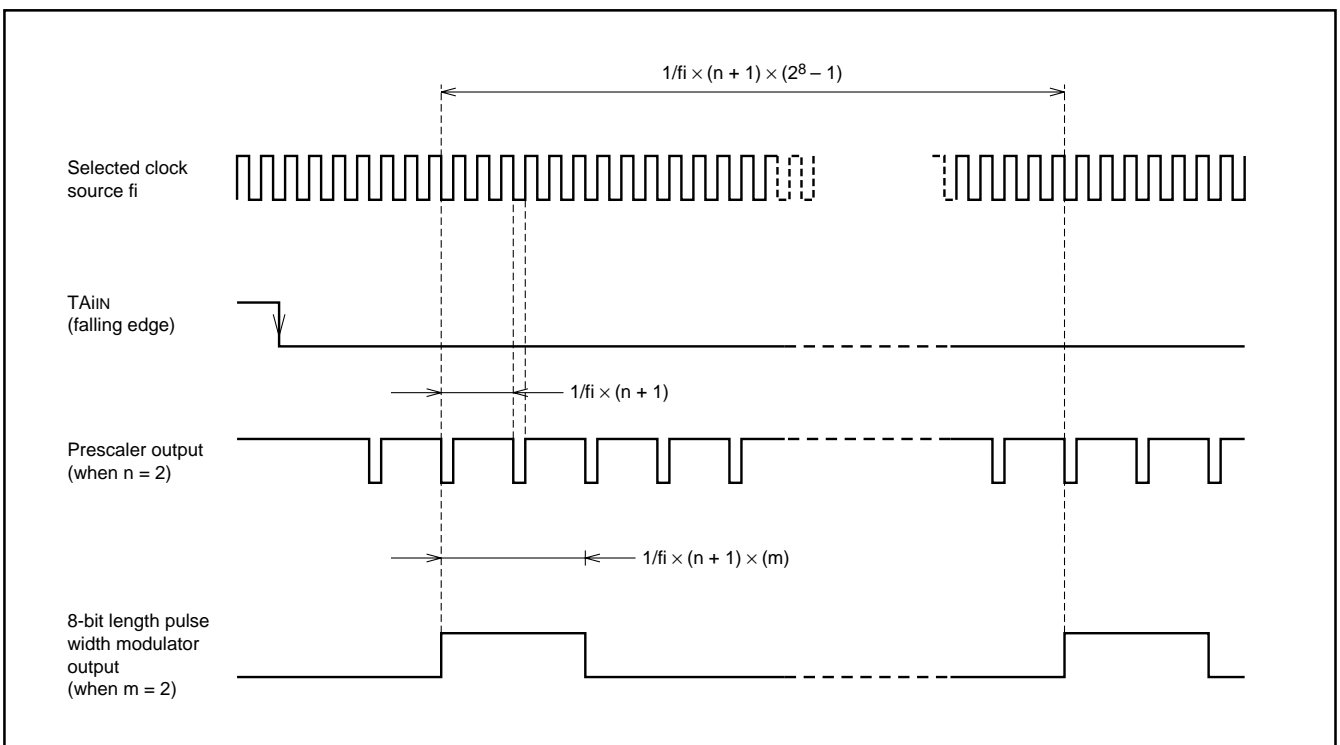

Fig. 57 8-bit length pulse width modulator output pulse example

MITSUBISHI MICROCOMPUTERS

# M37902FCCHP, M37902FGCHP, M37902FJCHP

SINGLE-CHIP 16-BIT CMOS MICROCOMPUTER

## TIMER B

Figure 58 shows a block diagram of timer B.

Timer B has three modes: timer mode, event counter mode, and pulse period measurement/pulse width measurement mode. The mode is selected with bits 0 and 1 of the timer Bi mode register (i=0 to 2). Each of these modes is described below.

### (1) Timer mode [00]

Figure 59 shows the bit configuration of the timer Bi mode register during timer mode. Bits 0 and 1 of the timer Bi mode register must always be "0" in timer mode.

Bits 6 and 7 are used to select the clock source. The counting of the selected clock starts when the count start bit is "1" and stops when "0".

As shown in Figure 44, the timer Bi count start bit is at the same address as the timer Ai count start bit. The count is decremented, an interrupt occurs, and the interrupt request bit in the timer Bi interrupt control register is set when the contents becomes 0000<sub>16</sub>. At the same time, the contents of the reload register is stored in the counter and count is continued.

Timer Bi does not have a pulse output function or a gate function like timer A.

When data is written to timer Bi halted, it is written to the reload register and the counter. When data is written to timer Bi which is busy, the data is written to the reload register, but not to the counter. The new data is reloaded from the reload register to the counter at the next reload time and counting continues.

The contents of the counter can be read at any time.

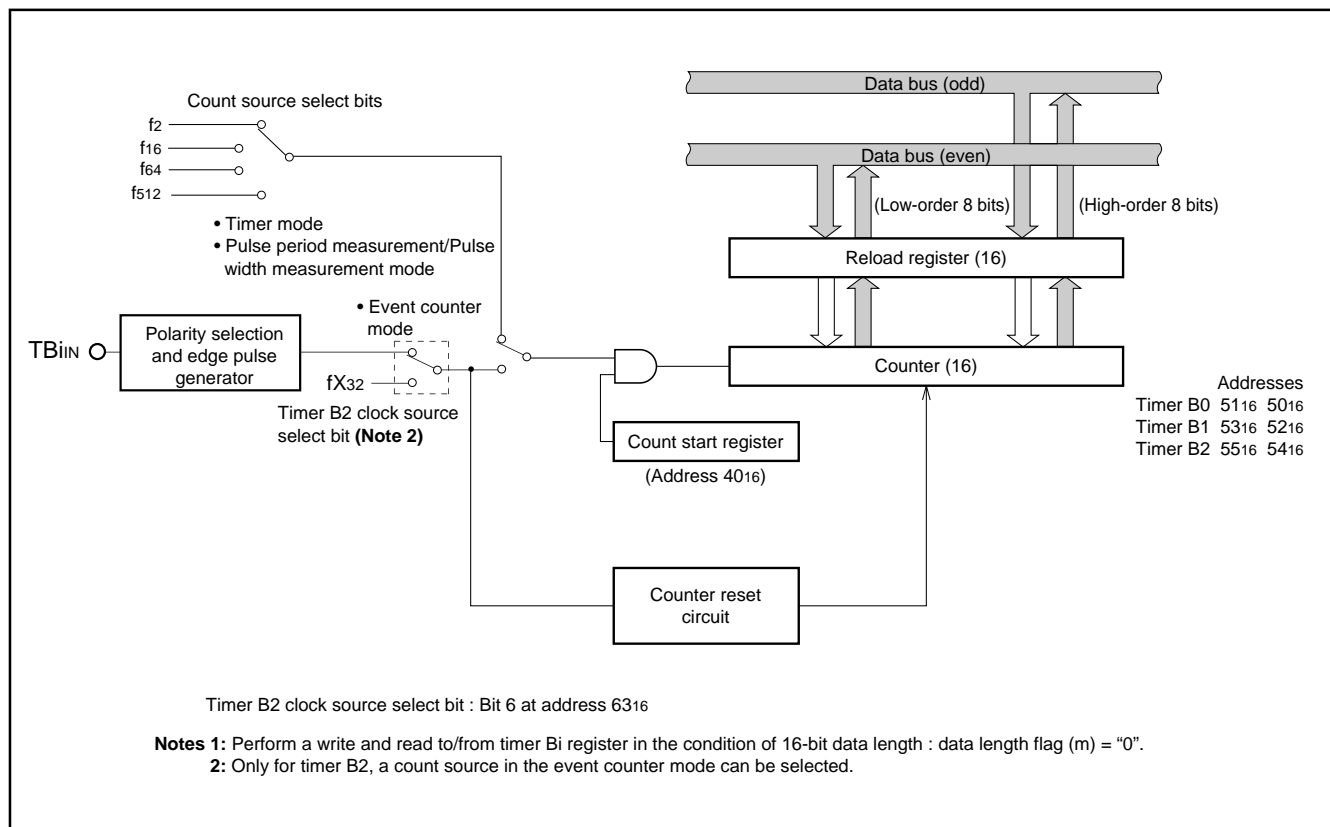

Fig. 58 Block diagram of timer B

# MITSUBISHI MICROCOMPUTERS

## M37902FCCHP, M37902FGCHP, M37902FJCHP

SINGLE-CHIP 16-BIT CMOS MICROCOMPUTER

### (2) Event counter mode [01]

Figure 60 shows the bit configuration of the timer Bi mode register during event counter mode. In event counter mode, bit 0 in the timer Bi mode register must be "1" and bit 1 must be "0".

The input signal from the TBiIN pin is counted when the count start bit is "1" and counting is stopped when it is "0".

Count is performed at the fall of the input signal when bits 2, and 3 are "0" and at the rise of the input signal when bit 3 is "0" and bit 2 is "1".

When bit 3 is "1" and bit 2 is "0", count is performed at the rise and fall of the input signal.

Data write, data read and timer interrupt are performed in the same way as for timer mode.

Only for timer B2, when the timer B2 clock source select bit of the particular function select register 1 (bit 6 at address 6316) = "1" in the event counter mode, fX32 can be selected. (When this bit is "0", an input signal from pin TB2IN becomes the count source as described above.) For the bit configuration of the particular function select register 1, refer to the section on the standby function.

Note:  $fX32 = f(XIN)/32$

### (3) Pulse period measurement/Pulse width measurement mode [10]

Figure 61 shows the bit configuration of the timer Bi mode register during pulse period measurement/pulse width measurement mode. In pulse period measurement/pulse width measurement mode, bit 0 must be "0" and bit 1 must be "1". Bits 6 and 7 are used to select the clock source. The selected clock is counted when the count start bit is "1" and counting stops when it is "0".

The pulse period measurement mode is selected when bit 3 is "0". In pulse period measurement mode, the selected clock is counted during the interval starting at the fall of the input signal from the TBiIN pin to the next fall or at the rise of the input signal to the next rise; the result is stored in the reload register. In this case, the reload register acts as a buffer register.

When bit 2 is "0", the clock is counted from the fall of the input signal to the next fall. When bit 2 is "1", the clock is counted from the rise of the input signal to the next rise.

In the case of counting from the fall of the input signal to the next fall, counting is performed as follows. As shown in Figure 62, when the fall of the input signal from TBiIN pin is detected, the contents of the counter is transferred to the reload register. Next, the counter is cleared and count is started from the next clock. When the fall of the next input signal is detected, the contents of the counter is transferred to the reload register once more, the counter is cleared, and the count is started. The period from the fall of the input signal to the next fall is measured in this way.

After the contents of the counter is transferred to the reload register, an interrupt request signal is generated and the interrupt request bit in the timer Bi interrupt control register is set. However, no interrupt request signal is generated when the contents of the counter is transferred first to the reload register after the count start bit is set to "1".

When bit 3 is "1", the pulse width measurement mode is selected. Pulse width measurement mode is the same as the pulse period measurement mode except that the clock is counted from the fall of the TBiIN pin input signal to the next rise or from the rise of the input signal to the next fall as shown in Figure 63.

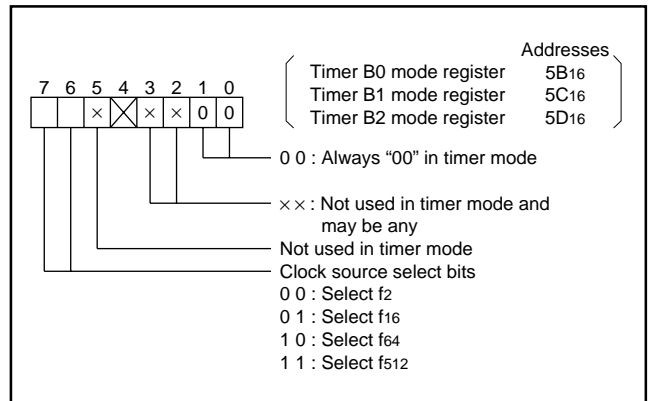

Fig. 59 Bit configuration of timer Bi mode register during timer mode

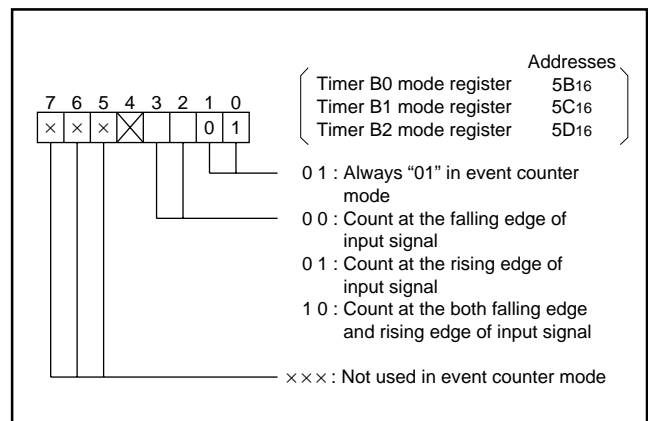

Fig. 60 Bit configuration of timer Bi mode register during event counter mode

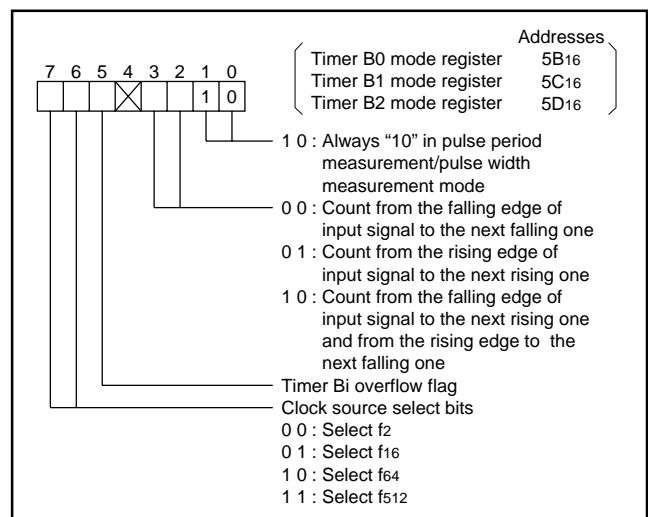

Fig. 61 Bit configuration of timer Bi mode register during pulse period measurement/pulse width measurement mode

MITSUBISHI MICROCOMPUTERS

# M37902FCCHP, M37902FGCHP, M37902FJCHP

SINGLE-CHIP 16-BIT CMOS MICROCOMPUTER

When timer Bi is read, the contents of the reload register is read.  
 Note that in this mode, the interval between the fall of the TBiIn pin input signal to the next rise or from the rise to the next fall must be at least two cycles of the timer count source.

Timer Bi overflow flag which is bit 5 of timer Bi mode register is set to "1" when the timer Bi counter reaches  $0000_{16}$ , which indicates that a pulse width or pulse period is longer than that which can be measured by a 16-bit length.

This flag is cleared by writing data to the corresponding timer Bi mode register. This flag is set to "1" at reset.

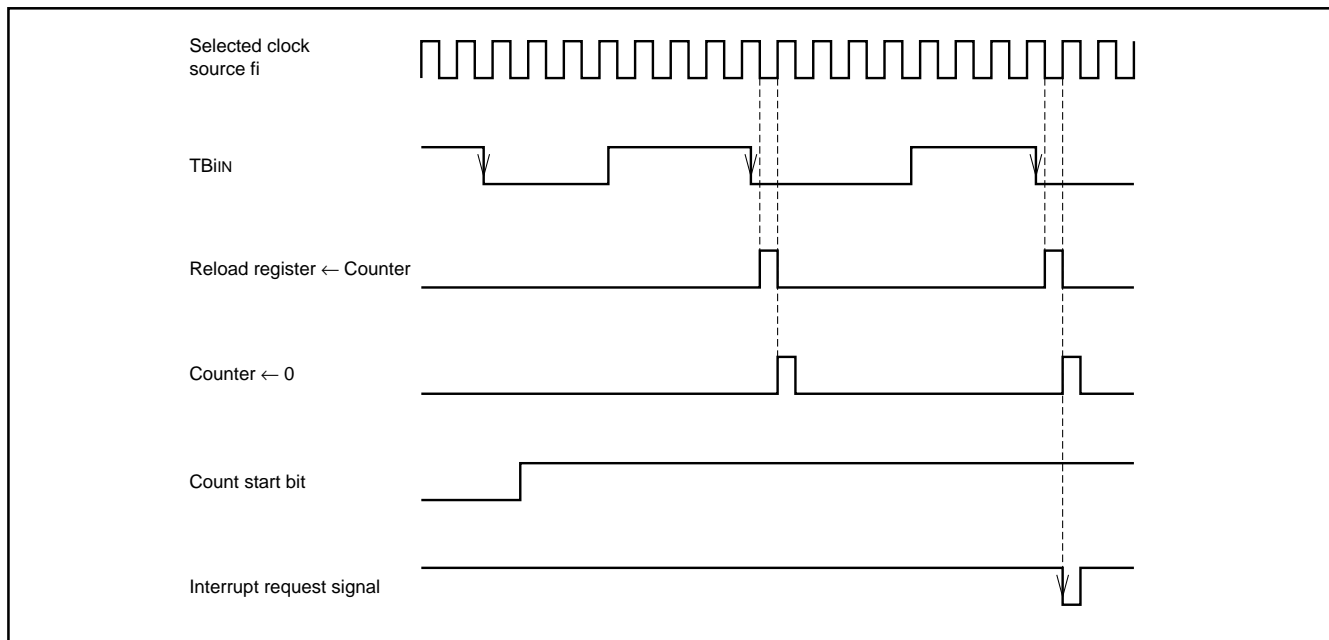

Fig. 62 Pulse period measurement mode operation (example of measuring the interval between the falling edge to next falling one)

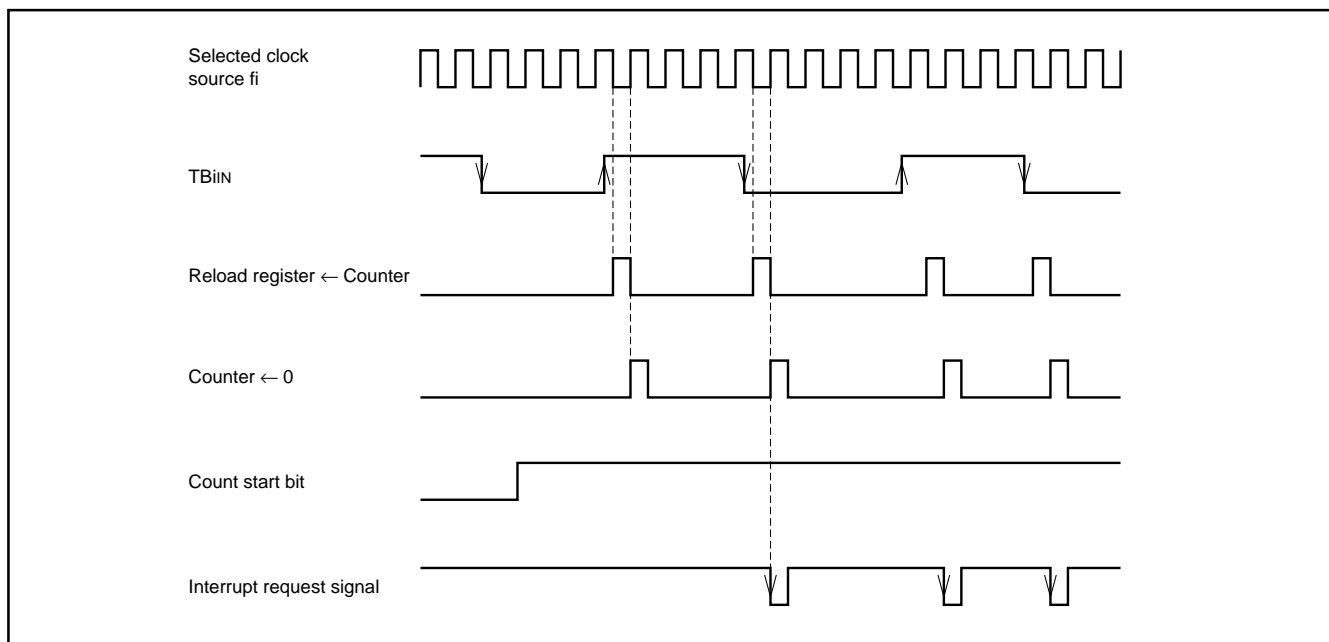

Fig. 63 Pulse width measurement mode operation

# MITSUBISHI MICROCOMPUTERS

## M37902FCCHP, M37902FGCHP, M37902FJCHP

SINGLE-CHIP 16-BIT CMOS MICROCOMPUTER

### SERIAL I/O PORTS

Two independent serial I/O ports are provided. Figure 64 shows a block diagram of the serial I/O ports.

Bits 0 to 2 of the UART<sub>i</sub> (i = 0,1) transmit/receive mode register shown in Figure 65 are used to determine whether to use port P8 as a programmable I/O port, clock synchronous serial I/O port, or asyn-

chronous (UART) serial I/O port which uses start and stop bits.

Figures 66 and 67 show the block diagrams of the receiver/transmitter.

Figure 68 shows the bit configuration of the UART<sub>i</sub> transmit/receive control register.

Each communication method is described below.

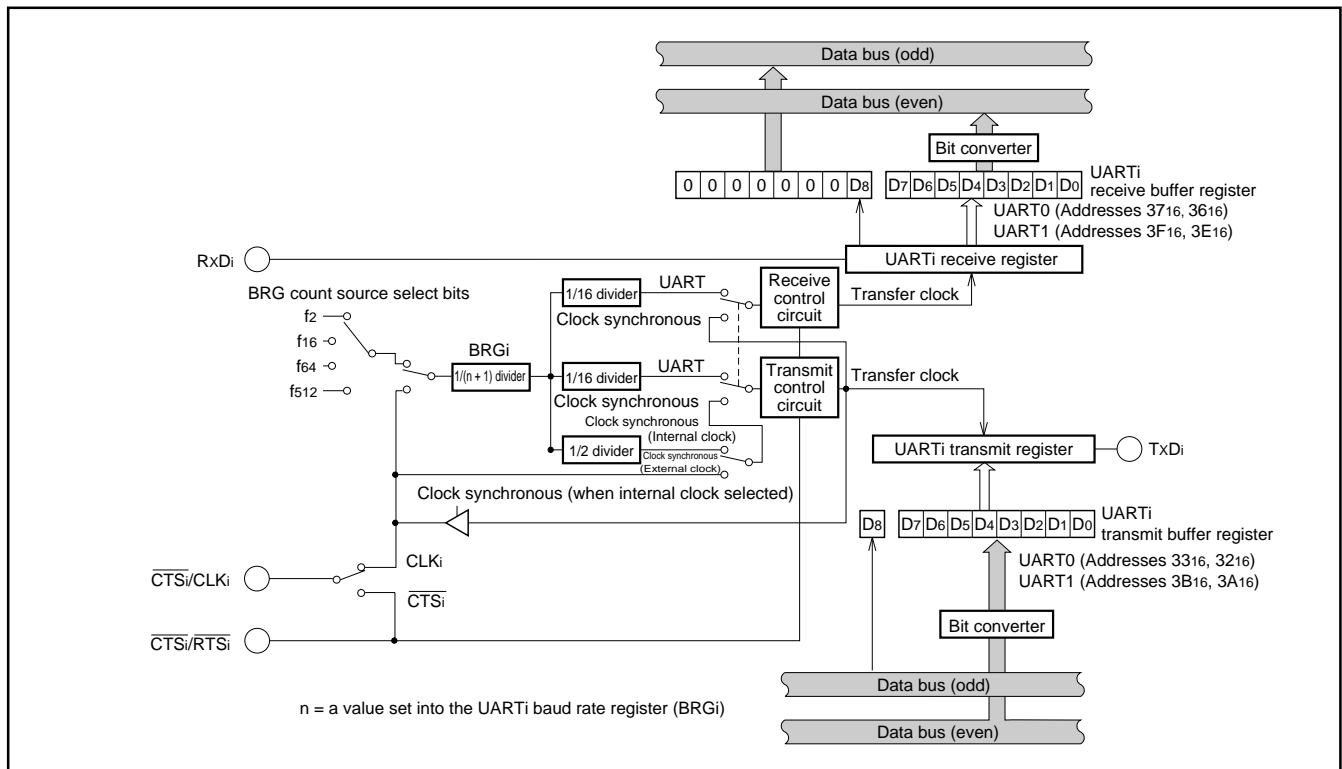

Fig. 64 Block diagram of serial I/O port

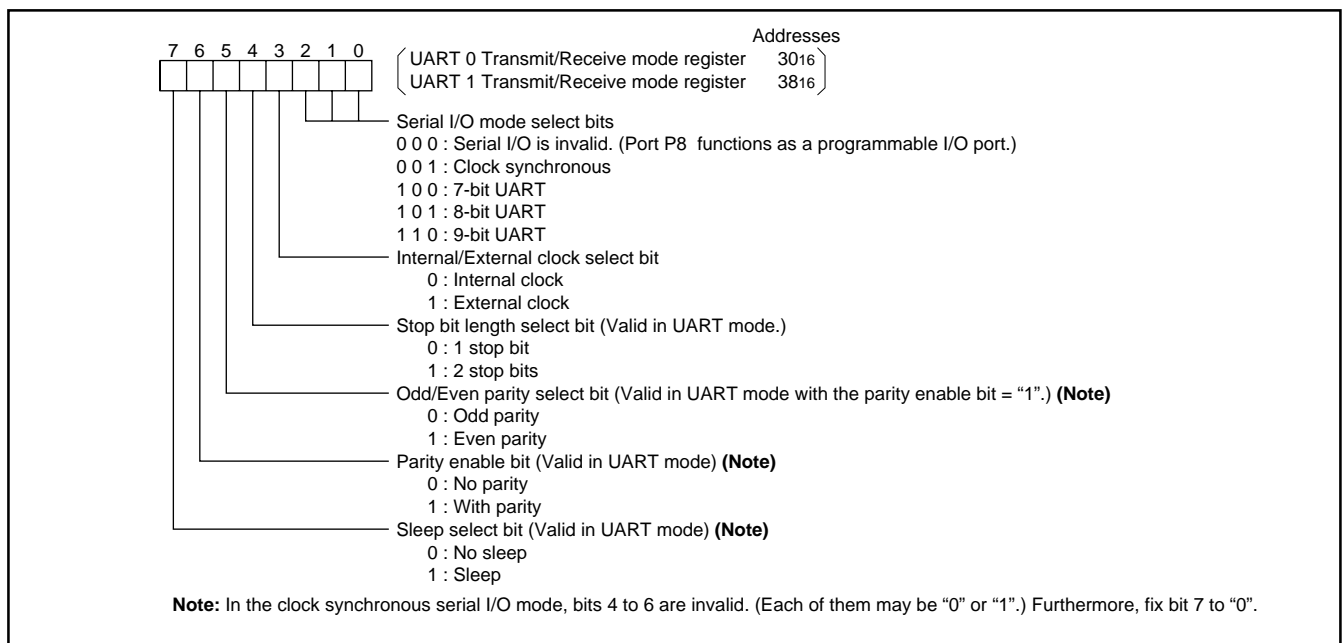

Fig. 65 Bit configuration of UART<sub>i</sub> transmit/receive mode register



MITSUBISHI MICROCOMPUTERS  
**M37902FCCHP, M37902FGCHP, M37902FJCHP**

SINGLE-CHIP 16-BIT CMOS MICROCOMPUTER

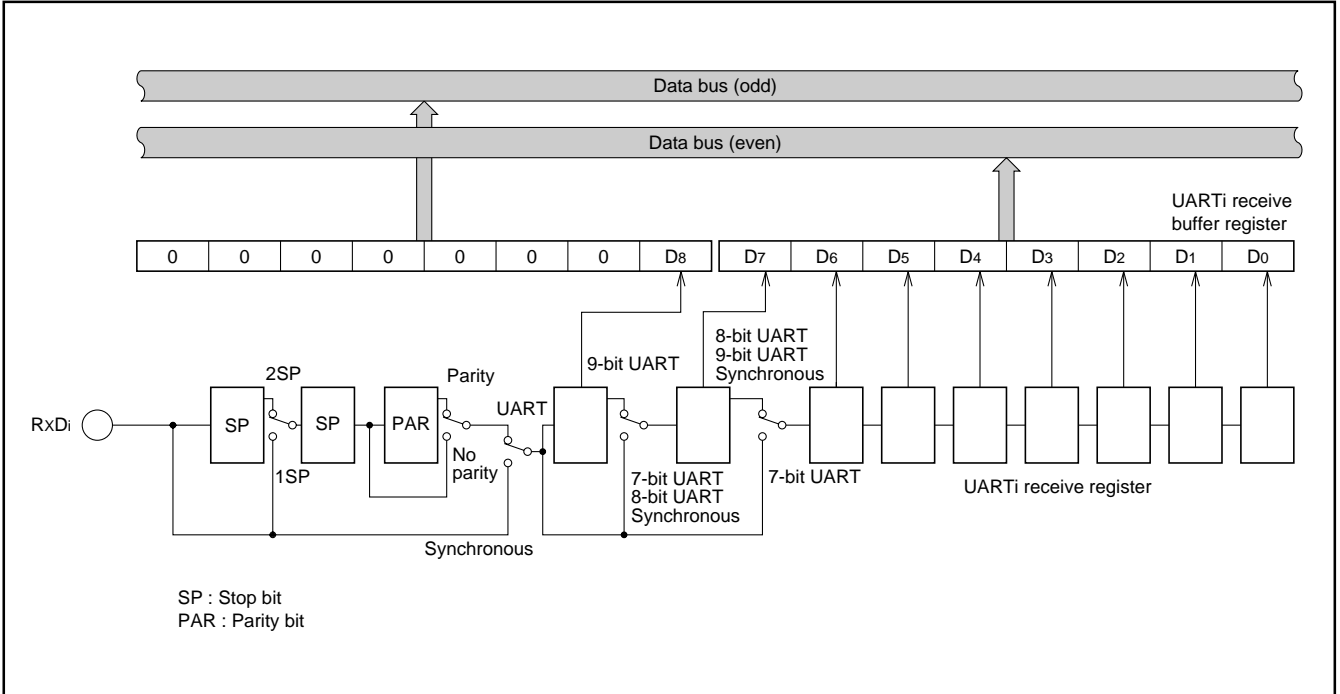

Fig. 66 Block diagram of receiver

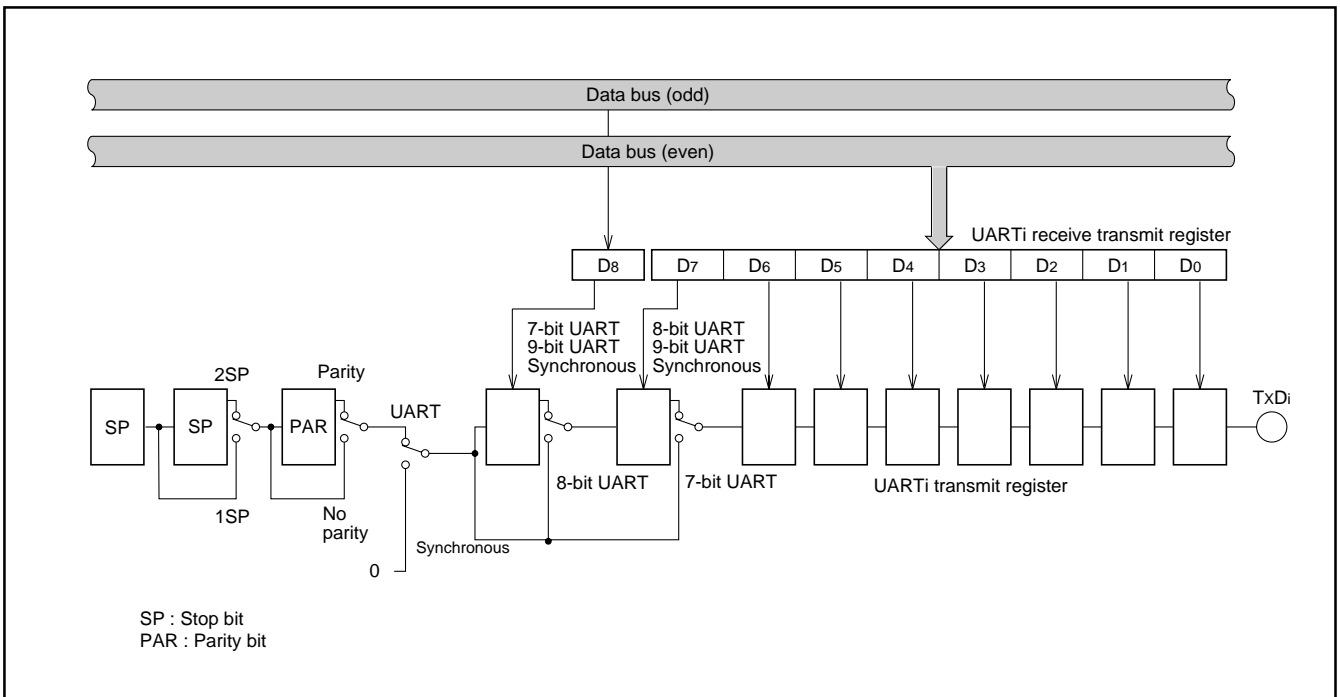
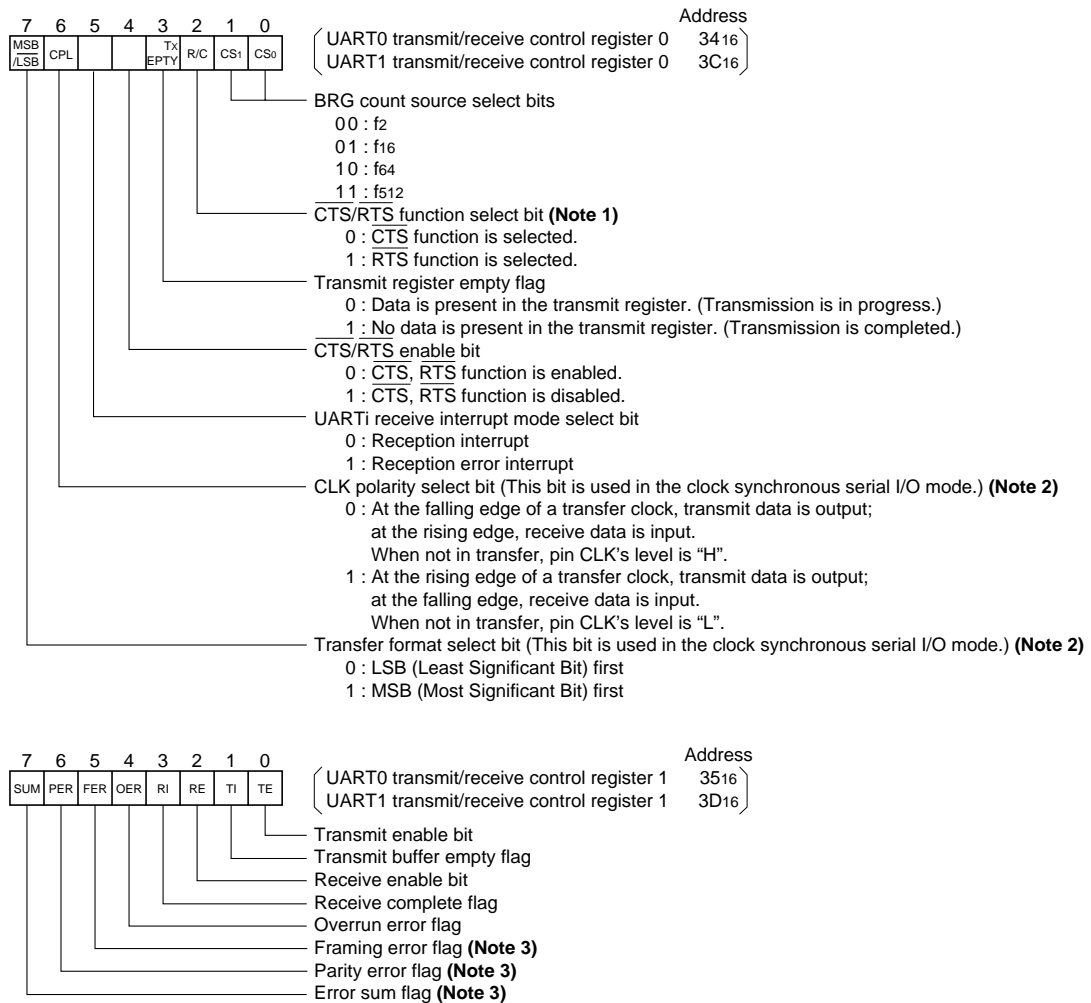

Fig. 67 Block diagram of transmitter

MITSUBISHI MICROCOMPUTERS

# M37902FCCHP, M37902FGCHP, M37902FJCHP

SINGLE-CHIP 16-BIT CMOS MICROCOMPUTER



**Notes 1:** Valid when the CTS/RTS enable bit (bit 4) = "0".  
**2:** Fix these bits to "0" in UART mode or when serial I/O is invalid.  
**3:** Valid in UART mode.

Fig. 68 Bit configuration of UART<sub>i</sub> transmit/receive control register

### CLOCK SYNCHRONOUS SERIAL COMMUNICATION

A case where communication is performed between two clock synchronous serial I/O ports as shown in Figure 69 will be described. (The transmission side will be denoted by subscript j and the receiving side will be denoted by subscript k.)

Bit 0 of the UARTj transmit/receive mode register and UARTk transmit/receive mode register must be set to "1" and bits 1 and 2 must be "0". The length of the transmission data is fixed at 8 bits.

Bit 3 of the UARTj transmit/receive mode register of the clock sending side is cleared to "0" to select the internal clock. Bit 3 of the UARTk transmit/receive mode register of the clock receiving side is set to "1" to select the external clock. Bits 4, 5 and 6 are ignored in clock synchronous mode. Bit 7 must always be "0".

The clock source is selected by bit 0 (CS0) and bit 1 (CS1) of the clock-sending-side UARTj transmit/receive control register 0. As shown in Figure 64, the selected clock is divided by (n+1), then by 2, is passed through a transmission control circuit, and is output as transmission clock CLKj. Therefore, when the selected clock is fi,

$$\text{Bit Rate} = f_i / \{(n + 1) \times 2\}$$

On the clock receiving side, the CS0 and CS1 bits of the UARTk transmit/receive control register 0 are ignored because an external clock is selected.

Both of UART0 and UART1 can use  $\overline{\text{CTS}}$  and  $\overline{\text{RTS}}$  functions. Bit 4 of the UARTi transmit/receive control register 0 is used to determine whether to use  $\overline{\text{CTS}}$  or  $\overline{\text{RTS}}$  signal. Bit 4 must be "0" when  $\overline{\text{CTS}}$  or  $\overline{\text{RTS}}$  signal is used. Bit 4 must be "1" when  $\overline{\text{CTS}}$  and  $\overline{\text{RTS}}$  signals are not used. When  $\overline{\text{CTS}}$  and  $\overline{\text{RTS}}$  signals are not used,  $\overline{\text{CTS}}$ / $\overline{\text{RTS}}$  pin can be used as a normal port pin.

When using pin  $\overline{\text{CTS}}$ / $\overline{\text{RTS}}$ , :

- If bit 2 of the UARTi transmit/receive control register 0 is cleared to "0",  $\overline{\text{CTS}}$  input is selected.
- If bit 2 is set to "1",  $\overline{\text{RTS}}$  output is selected.

The case using  $\overline{\text{CTS}}$  and  $\overline{\text{RTS}}$  signals are explained below. As shown in Figure 76, bits 2 and 3 of the serial I/O pin control register can determine whether port pins P83 and P87 are used as pins TxDi or as port pins. When bits 2 and 3 are "0", P83 and P87 function as pins TxDi; when bits 2 and 3 are "1", P83 and P87 function as port pins. Therefore, in the input-only system where pins TxDi are not used, pins TxDi can function as port pins.

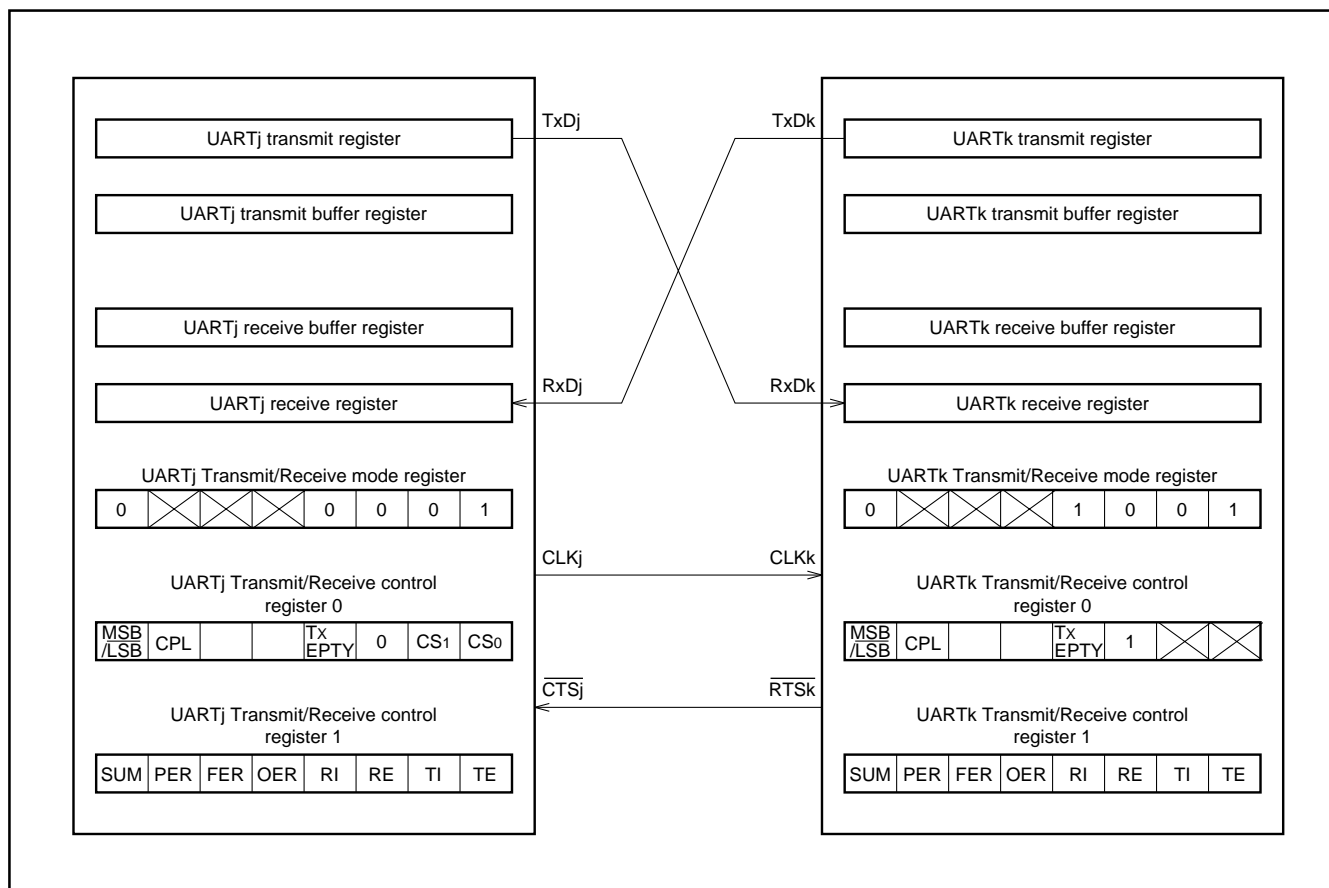

Fig. 69 Clock synchronous serial communication

MITSUBISHI MICROCOMPUTERS

# M37902FCCHP, M37902FGCHP, M37902FJCHP

SINGLE-CHIP 16-BIT CMOS MICROCOMPUTER

---

## Transmission

Transmission is started when bit 0 (TE<sub>j</sub> flag: transmit enable bit) of UART<sub>j</sub> transmit/receive control register 1 is "1", bit 1 (Tl<sub>j</sub> flag) of one is "0", and CTS<sub>j</sub> input is "L". The Tl<sub>j</sub> flag indicates whether the transmit buffer register is empty or not. It is cleared to "0" when data is written in the transmit buffer register; it is set to "1" when the contents of the transmit buffer register is transferred to the transmit register and the transmit buffer register becomes empty.

When all of the transmit conditions are satisfied, the transmit data in the transmit buffer register are transferred to the transmit register, and transmission starts. As shown in Figure 70, data is output from Tx<sub>Dj</sub> pin each time when transmission clock CLK<sub>j</sub> changes from "H" to "L". (In the clock synchronous serial I/O mode, the polarity of a transfer clock can be changed. For details, refer to the section on the selection of the transfer clock polarity.) The data is output from the least significant bit.

When the transmit register becomes empty after the contents has been transmitted, data is transferred automatically from the transmit buffer register to the transmit register if the next transmission start condition is satisfied. The next transmission is performed succeedingly. Once transmission has started, the TE<sub>j</sub> flag, Tl<sub>j</sub> flag, and CTS<sub>j</sub> signals are ignored until data transmission completes. Therefore, transmission is not interrupt when  $\overline{\text{CTS}}_j$  input is changed to "H" during transmission.

The transmission start condition indicated by TE<sub>j</sub> flag, Tl<sub>j</sub> flag, and  $\overline{\text{CTS}}_j$  is checked while the TEND<sub>j</sub> signal (shown in Figure 70) is "H". Therefore, data can be transmitted continuously if the next transmission data is written in the transmit buffer register and Tl<sub>j</sub> flag is cleared to "0" before the TEND<sub>j</sub> signal goes "H".

Bit 3 (TxEPTY<sub>j</sub> flag) of UART<sub>j</sub> transmit/receive control register 0 changes to "1" at the next cycle just after the TEND<sub>j</sub> signal goes "H" and changes to "0" when transmission starts. Therefore, this flag can be used to determine whether data transmission has completed.

When the Tl<sub>j</sub> flag changes from "0" to "1", the interrupt request bit in the UART<sub>j</sub> transmit interrupt control register is set to "1".

## Receive

When bit 2 of the UART<sub>k</sub> transmit/receive control register 1 is set to "1", reception becomes enabled. In this case, when the CLK<sub>k</sub> signal is input, the receive operation starts simultaneously with this signal. The RTS<sub>k</sub> output is "H" when the REK flag is "0". When the REK flag is set to "1", the RTS<sub>k</sub> output becomes "L". This informs the transmitter side that reception becomes enabled. When the receive operation starts, the RTS<sub>k</sub> output automatically becomes "H".

When the receive operation starts, the receiver takes data from pin Rx<sub>Dk</sub> each time when the transmit clock (CLK<sub>j</sub>) turns from "L" to "H". Simultaneously with reception, the contents of the receiver register is shifted bit by bit.

(Note that, in the clock synchronous serial communication, the polarity of a transfer clock can be inverted. For details, refer to the section on the polarity of the transfer clock.) When an 8-bit data is received, the contents of the receive register is transferred to the receive buffer register and bit 3 (Rl<sub>k</sub> flag) of UART<sub>k</sub> transmit/receive control register 1 is set to "1". In other words, the setting "1" to the Rl<sub>k</sub> flag indicates that the receive buffer register contains the received data. At this time, if the low-order byte of the UART<sub>k</sub> receive buffer register is read out, the RTS<sub>k</sub> output turns back to "L". This indicates that the

next data reception becomes enabled. Bit 4 (OER<sub>k</sub> flag) of UART<sub>k</sub> transmit/receive control register 1 is set to "1" when the next data is transferred from the receive register to the receive buffer register while Rl<sub>k</sub> flag is "1", and indicates that the next data was transferred to the receive register before the contents of the receive buffer register was read. (In other words, this indicates that an overrun error has occurred.) Rl<sub>k</sub> flag is automatically cleared to "0" when the low-order byte of the receive buffer register is read or when the RE<sub>k</sub> flag is cleared to "0". The OER<sub>k</sub> flag is cleared when the RE<sub>k</sub> flag is cleared. Bit 5 (FER<sub>k</sub> flag), bit 6 (PER<sub>k</sub> flag), and bit 7 (SUM<sub>k</sub> flag) are ignored in clock synchronous mode.

As shown in Figure 64, with clock synchronous serial communication, data cannot be received unless the transmitter is operating because the receive clock is created from the transmission clock. Therefore, the transmitter must be operating even when there is no need to sent data from UART<sub>k</sub> to UART<sub>j</sub>.

MITSUBISHI MICROCOMPUTERS

# M37902FCCHP, M37902FGCHP, M37902FJCHP

SINGLE-CHIP 16-BIT CMOS MICROCOMPUTER

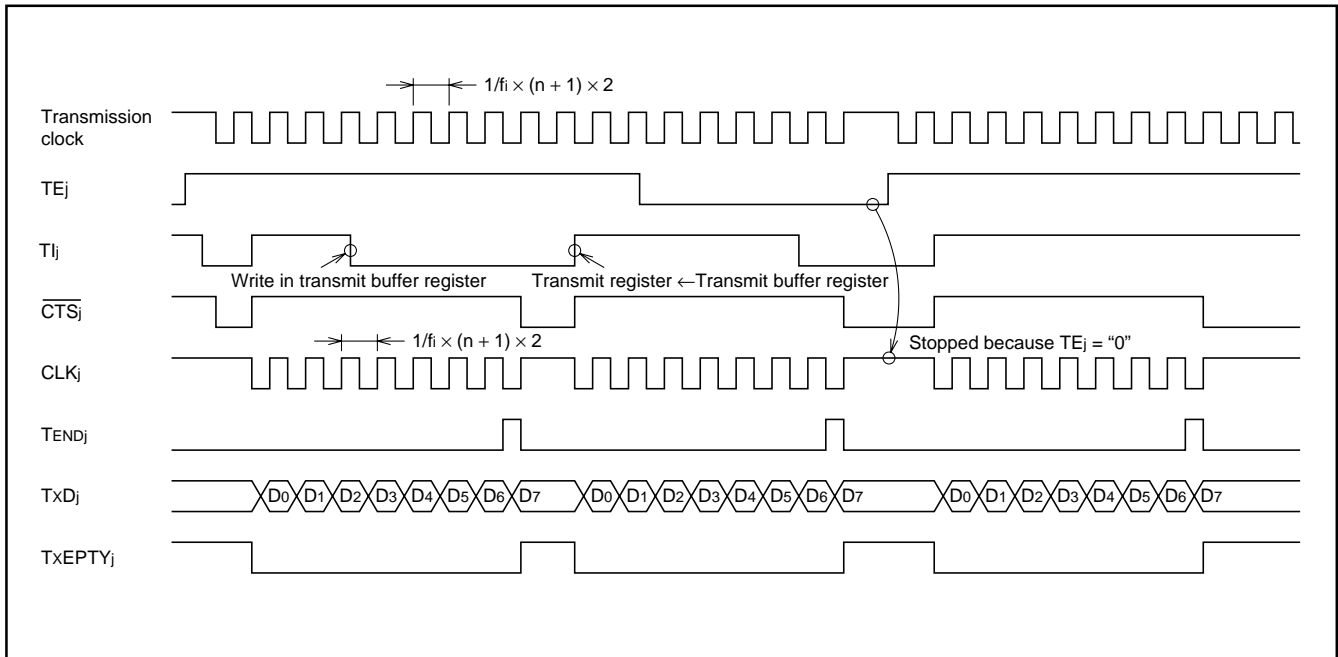

Fig. 70 Clock synchronous serial I/O timing

### Interrupt request at completion of reception

When the RIK flag changes from "0" to "1", in other words, when the receive operation is completed, the interrupt request bit of the UART<sub>k</sub> receive interrupt control register can be set to "1".

The timing when this interrupt request bit is to be set to "1" can be selected from the following:

- Each reception
- When an error occurs at reception

If bit 5 of the UART<sub>k</sub> transmit/receive control register 0 (UART receive interrupt mode select bit) is cleared to "0", the interrupt request bit is set to "1" at each reception. If bit 5 is set to "1", the interrupt request bit is set to "1" only when an error occurs. (In the clock synchronous serial communication, only when an overrun error occurs, the interrupt request bit is set to "1".)

### Polarity of transfer clock

In the clock synchronous serial communication, by bit 6 of the UART<sub>j</sub> transmit/receive control register 0 (CPL), the polarity of a transfer clock can be selected.

As shown in Figure 71, when bit 6 = "0", the polarity is as follows:

- In transmission, transmit data is output at the falling edge of CLK<sub>j</sub>.
- In reception, receive data is input at the rising edge of CLK<sub>k</sub>.
- When not in transfer, CLK<sub>i</sub> is at "H" level.

When bit 6 = "1", the polarity is as follows:

- In transmission, transmit data is output at the rising edge of CLK<sub>j</sub>.
- In reception, receive data is input at the rising edge of CLK<sub>k</sub>.
- When not in transfer, CLK<sub>i</sub> is at "L" level.

MITSUBISHI MICROCOMPUTERS  
**M37902FCCHP, M37902FGCHP, M37902FJCHP**

SINGLE-CHIP 16-BIT CMOS MICROCOMPUTER

■ CLK polarity select bit = 0

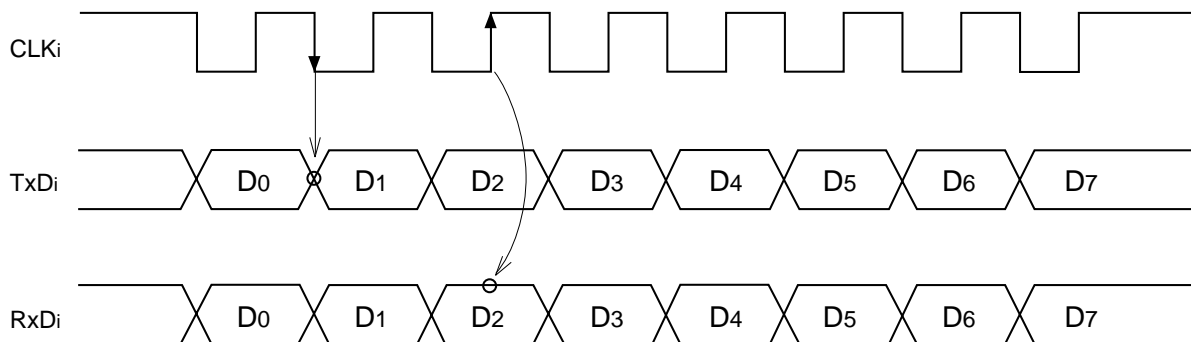

※ Transmit data is output to pin TxDi at the falling edge of transfer clock, and receive data is input from pin RxDi at the rising edge of transfer clock.  
When not in transfer, pin CLKi's level is "H".

■ CLK polarity select bit = 1

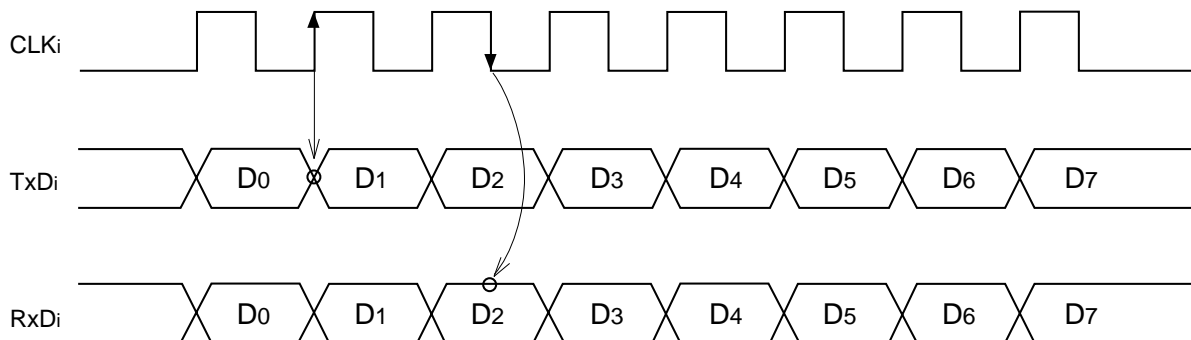

※ Transmit data is output to pin TxDi at the rising edge of transfer clock, and receive data is input from pin RxDi at the falling edge of transfer clock.  
When not in transfer, pin CLKi's level is "L".

Fig. 71 Polarity of transfer clock

MITSUBISHI MICROCOMPUTERS

# M37902FCCHP, M37902FGCHP, M37902FJCHP

SINGLE-CHIP 16-BIT CMOS MICROCOMPUTER

### Selection of transfer format

In clock synchronous serial communication, transfer format can be selected by bit 7 of the transmit/receive control register 0. When bit 7 is "0", transfer format is LSB first. When bit 7 is "1", transfer format is MSB first.

This function is realized by changing connection relation between

the transmit buffer register and the receive buffer register when writing transmit data to the transmit buffer register or reading receive data from the receive buffer register. Accordingly, the transmitter's operation is the same in both transfer formats.

Figure 72 shows the connection relation.

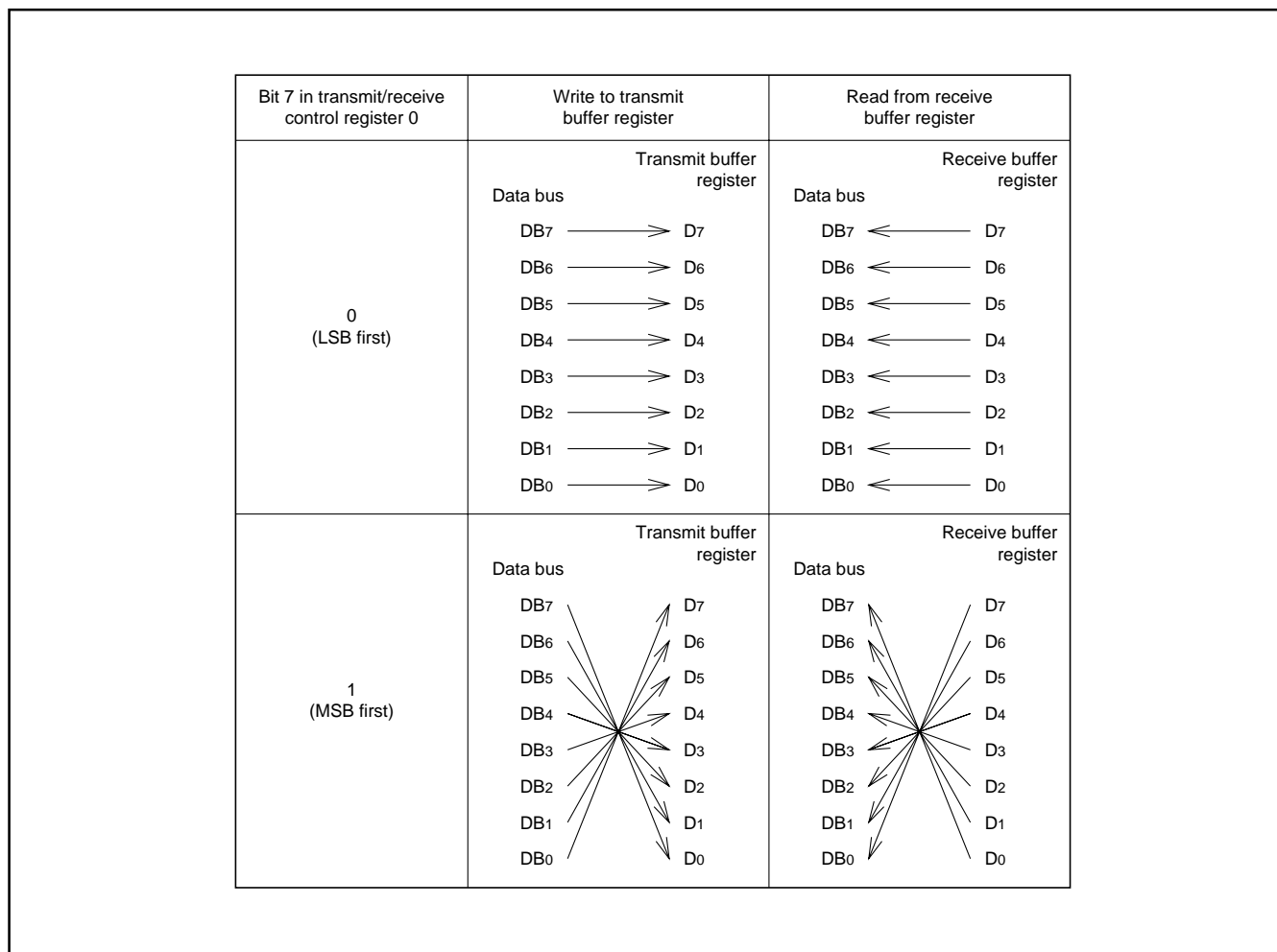

Fig. 72 Connection relation between transmit buffer register, receive buffer register, and data bus

### Precautions for clock synchronous serial communication

When using pin  $\overline{CTS_0}/\overline{RTS_0}$ , be sure to clear the D-A2 output enable bit (bit 2 at address 9616) to "0" (output disabled). Also, in the clock synchronous serial communication, the separate function for  $\overline{CTS_i}/\overline{RTS_i}$  cannot be selected. Furthermore, when an internal clock is selected,  $\overline{RTS}$  output is undefined. Therefore, do not use the  $\overline{RTS}$  function.

Before transmit operation is performed, be sure to clear bits 2 and 3 of the serial I/O pin control register (address AC16) to "00".

# MITSUBISHI MICROCOMPUTERS

## M37902FCCHP, M37902FGCHP, M37902FJCHP

SINGLE-CHIP 16-BIT CMOS MICROCOMPUTER

### ASYNCHRONOUS SERIAL COMMUNICATION

Asynchronous serial communication can be performed using 7-, 8-, or 9-bit length data. The operation is the same for all data lengths. The following is the description for 8-bit asynchronous communication.

With 8-bit asynchronous communication, bit 0 of UARTi transmit/receive mode register is "1", bit 1 is "0", and bit 2 is "1".

Bit 3 is used to select an internal clock or an external clock. If bit 3 is "0", an internal clock is selected and if bit 3 is "1", then external clock is selected. If an internal clock is selected, bit 0 (CS0) and bit 1 (CS1) of UARTi transmit/receive control register 0 are used to select the clock source. When an internal clock is selected for asynchronous serial communication, the CLKi pin can be used as a normal I/O pin. The selected internal or external clock is divided by (n+1), then by 16, and is passed through a control circuit to create the UART transmission clock or UART receive clock.

Therefore, the transmission speed can be changed by changing the contents (n) of the bit rate generator. If the selected clock is an internal clock Pfi or an external clock fEXT,

$$\text{Bit Rate} = (f_i \text{ or } f_{\text{EXT}}) / \{(n+1) \times 16\}$$

Bit 4 is the stop bit length select bit to select 1 stop bit or 2 stop bits. Bit 5 is a select bit of odd parity or even parity.

In the odd parity mode, the parity bit is adjusted so that the sum of 1s in the data and parity bit is always odd.

In the even parity mode, the parity bit is adjusted so that the sum of the 1s in the data and parity bit is always even.

Bit 6 is the parity bit select bit which indicates whether to add parity bit or not.

Bits 4 to 6 must be set or reset according to the data format used in the communicating devices.

Bit 7 is the sleep select bit. The sleep mode is described later.

Figure 76 shows the bit configuration of the serial I/O pin control register. By bits 0 and 1 of the serial I/O pin control register (CTS<sub>i</sub>/RTS<sub>i</sub> separate select bits), the function of the CTS<sub>i</sub>/RTS<sub>i</sub> pin can be separated into two functions, and each function can be assigned to two different pins. When bits 0 and 1 = "11", the above separation is performed. When bits 0 and 1 = "00", no separation is performed.

Table 13 lists the selection methods of the CTS<sub>i</sub>/RTS<sub>i</sub> function.

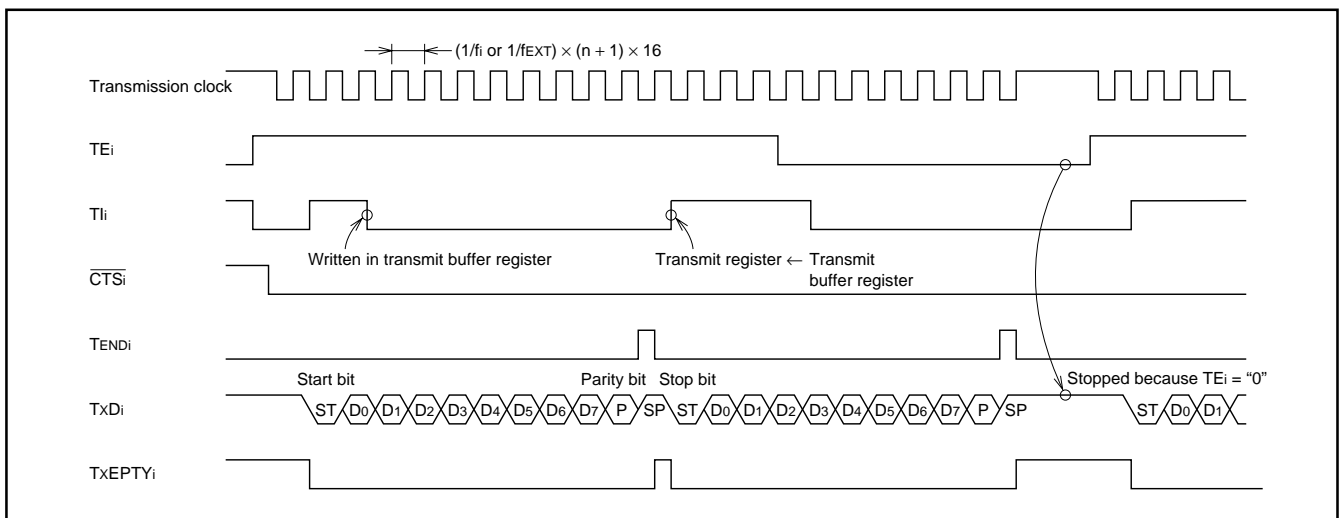

Fig. 73 Transmit timing example when 8-bit asynchronous communication with parity and 1 stop bit selected

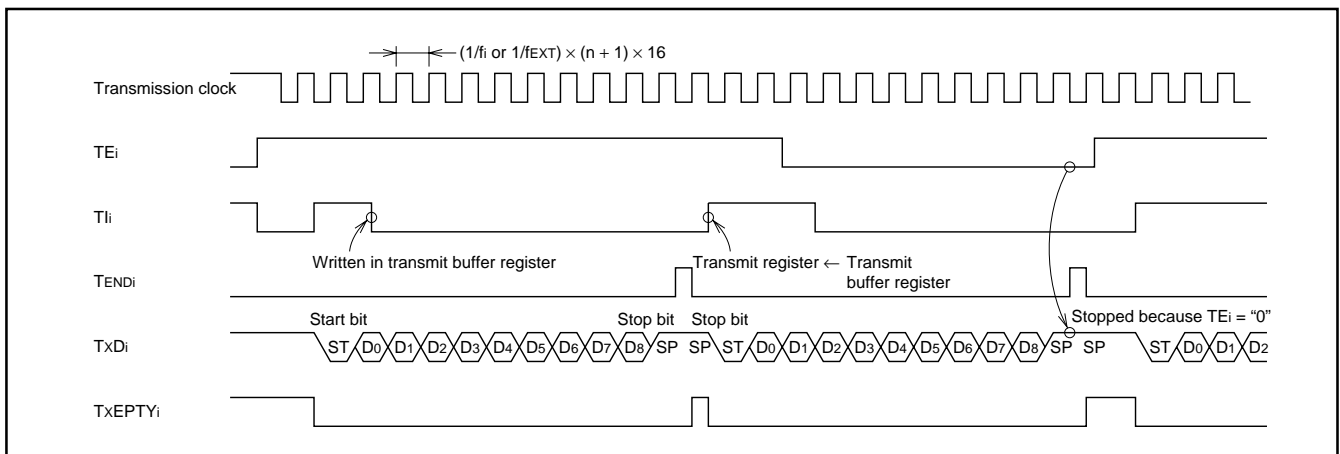

Fig. 74 Transmit timing example when 9-bit asynchronous communication with no parity and 2 stop bits selected



MITSUBISHI MICROCOMPUTERS

# M37902FCCHP, M37902FGCHP, M37902FJCHP

SINGLE-CHIP 16-BIT CMOS MICROCOMPUTER

## Transmission

Transmission is started when bit 0 (TEi flag transmit enable flag) of UARTi transmit/receive control register 1 is "1", bit 1 (Tli flag) is "0", and  $\overline{\text{CTS}}_i$  input (in other words, transmit enable signal input from receiver) is "L." The Tli flag indicates whether the transmit buffer is empty or not. It is cleared to "0" when data is written in the transmit buffer; it is set to "1" when the contents of the transmit buffer register is transferred to the transmit register.

When all of the transmission conditions are satisfied, transmit data is transferred to the transmit register, and transmit operation starts. As shown in Figures 73 and 74, data is output from the TxDi pin with the stop bit or parity bit specified by bits 4 to 6 of UARTi transmit/receive mode register. The data is output from the least significant bit. When the transmit register becomes empty after the contents has been transmitted, data is transferred automatically from the transmit buffer register to the transmit register if the next transmit start condition is satisfied. Then, the next transmission is performed succeedingly.

Once transmission has started, the TEi flag, Tli flag, and  $\overline{\text{CTS}}_i$  signal are ignored until data transmission is completed.

Therefore, transmission does not stop until it completes event if, during transmission, the TEi flag is cleared to "0" or  $\overline{\text{CTS}}_i$  input is set to "1".

The transmission start condition indicated by TEi flag, Tli flag, and  $\overline{\text{CTS}}_i$  is checked while the TENDi signal shown in Figure 73 is "H". Therefore, data can be transmitted continuously if the next transmission data is written in the transmit buffer register and Tli flag is cleared to "0" before the TENDi signal goes "H".

Bit 3 (TxEMPTYi flag) of UARTi transmit/receive control register 0 changes to "1" at the next cycle just after the TENDi signal goes "H" and changes to "0" when transmission starts. Therefore, this flag can be used to determine whether data transmission is completed.

When the Tli flag changes from "0" to "1", the interrupt request bit of the UARTi transmit interrupt control register is set to "1".

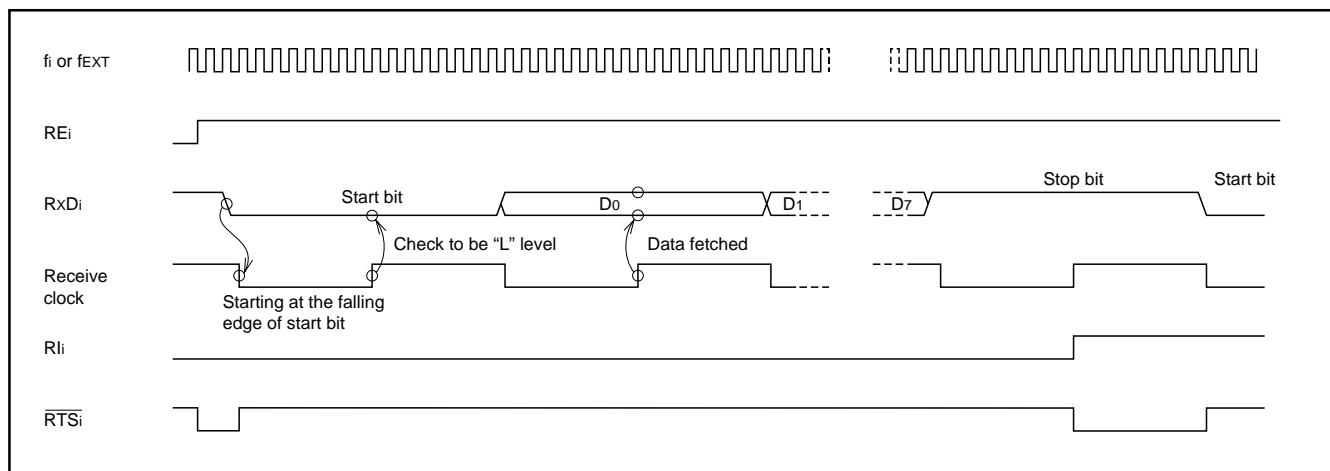

Fig. 75 Receive timing example when 8-bit asynchronous communication with no parity and 1 stop bit selected

MITSUBISHI MICROCOMPUTERS

# M37902FCCHP, M37902FGCHP, M37902FJCHP

SINGLE-CHIP 16-BIT CMOS MICROCOMPUTER

Table 13. Selection methods of  $\overline{\text{CTS}}/\overline{\text{RTS}}$  function

$\overline{\text{CTS}}/\overline{\text{RTS}}$ enable bit	$\overline{\text{CTS}}/\overline{\text{RTS}}_i$ separate select bit	$\overline{\text{CTS}}/\overline{\text{RTS}}$ function select bit	Functions			
			Pin P80/ $\overline{\text{CTS}}_0/\overline{\text{RTS}}_0$ (Note 1)	Pin P81/ $\overline{\text{CTS}}_0/\text{CLK}_0$	Pin P84/ $\overline{\text{CTS}}_1/\overline{\text{RTS}}_1$	Pin P85/ $\overline{\text{CTS}}_1/\text{CLK}_1$
0	0	0	$\overline{\text{CTS}}_0$	P81 or CLK <sub>0</sub>	$\overline{\text{CTS}}_1$	P85 or CLK <sub>1</sub>
		1	$\overline{\text{RTS}}_0$	P81 or CLK <sub>0</sub>	$\overline{\text{RTS}}_1$	P85 or CLK <sub>1</sub>
	1	X	$\overline{\text{RTS}}_0$	$\overline{\text{CTS}}_0$ (Notes 2 and 3)	$\overline{\text{RTS}}_1$	$\overline{\text{CTS}}_1$ (Notes 2 and 3)
1	X	X	P80	P81 or CLK <sub>0</sub>	P84	P85 or CLK <sub>1</sub>

X: It may be "0" or "1".

**Notes 1:** When using the  $\overline{\text{CTS}}_0/\overline{\text{RTS}}_0$  pin, be sure to clear the D-A<sub>2</sub> output enable bit (bit 2 at address 96<sub>16</sub>) to "0".

**2:** When using the  $\overline{\text{CTS}}$  function, be sure to clear the corresponding bit of the port P8 direction register to "0".

**3:** When  $\overline{\text{CTS}}_i$  and  $\overline{\text{RTS}}_i$  has been separated, the CLK<sub>i</sub> pin cannot be used. Therefore, in the clock synchronous serial communication,  $\overline{\text{CTS}}_i$  and  $\overline{\text{RTS}}_i$  cannot be separated. Also, when  $\overline{\text{CTS}}_i$  and  $\overline{\text{RTS}}_i$  are separated in UART mode, be sure to select an internal clock.

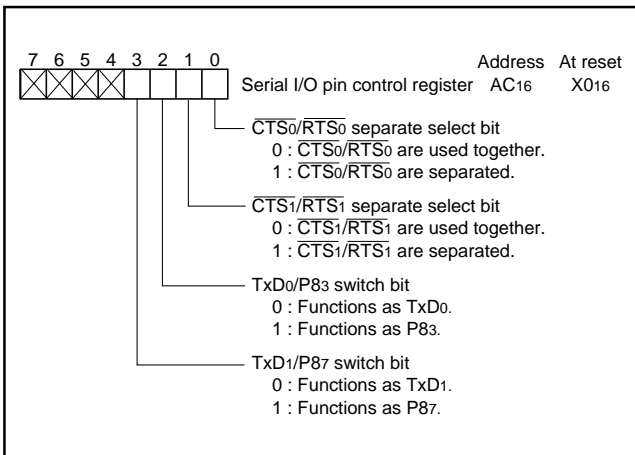

Fig. 76 Bit configuration of serial I/O pin control register

## Receive

Receive is enabled when bit 2 (REI flag) of UART<sub>i</sub> transmit/receive control register 1 is set to "1." As shown in Figure 75, the frequency divider circuit (1/16) at the receiving side begin to work when a start bit arrives and the data is received.

If  $\overline{\text{RTS}}_i$  output is selected by setting bit 2 of UART<sub>i</sub> transmit/receive control register 0 to "1", the  $\overline{\text{RTS}}_i$  output is "H" when the REI flag is "0". When the REI flag changes to "1", the  $\overline{\text{RTS}}_i$  output goes "L" to inform the receiver that reception has become enabled. When the receive operation starts, the  $\overline{\text{RTS}}_i$  output automatically becomes "H". The entire transmission data bits are received when the start bit passes the final bit of the receive block shown in Figure 66. At this point, the contents of the receive register is transferred to the receive buffer register and bit 3 (Rli flag) of UART<sub>i</sub> transmit/receive control register 1 is set to "1." In other words, the Rli flag indicates that the receive buffer register contains data when it is set to "1." At this time, when the low-order byte of the UART<sub>k</sub> receive buffer register is read out,  $\overline{\text{RTS}}_i$  output goes back to "L" to indicate that the register is ready to receive the next data.

Bit 4 (OERi flag) of UART<sub>i</sub> transmit/receive control register 1 is set to "1" when the next data is transferred from the receive register to the receive buffer register while the Rli flag is "1", in other words, when an overrun error occurs. If the OERi flag is "1", it indicates that the next data has been transferred to the receive buffer register before the contents of the receive buffer register has been read.

Bit 5 (FERi flag) is set to "1" when the number of stop bits is less than required (framing error).

Bit 6 (PERi flag) is set to "1" when a parity error occurs.

Bit 7 (SUMi flag) is set to "1" when either the OERi flag, FERi flag, or the PERi flag is set to "1." Therefore, the SUMi flag can be used to determine whether there is an error.

The setting of the Rli flag, OERi flag, FERi flag, and the PERi flag is performed while transferring the contents of the receive register to the receive buffer register.

MITSUBISHI MICROCOMPUTERS

# M37902FCCHP, M37902FGCHP, M37902FJCHP

SINGLE-CHIP 16-BIT CMOS MICROCOMPUTER

---

The FERi, PERi, and SUMi flags are cleared to "0" when reading the low-order byte of the receive buffer register or when writing "0" to the REi flag.

The OERi flag is cleared to "0" when writing "0" to the REi flag.

## Interrupt request at completion of reception

When the RIk flag changes from "0" to "1", in other words, when the receive operation is completed, the interrupt request bit of the UARTk receive interrupt control register can be set to "1".

The timing when this interrupt request bit is to be set to "1" can be selected from the following:

- Each reception
- When an error occurs at reception

If bit 5 of the UARTk transmit/receive control register 0 (UART receive interrupt mode select bit) is cleared to "0", the interrupt request bit is set to "1" at each reception. If bit 5 is set to "1", the interrupt request bit is set to "1" only when an error occurs. (In the clock asynchronous serial communication, when an overrun error, framing error, or parity error occurs, the interrupt request bit is set to "1".)

## Sleep mode

The sleep mode is used to communicate only between certain microcomputers when multiple microcomputers are connected through serial I/O.

The microcomputer enters the sleep mode when bit 7 of UARTi transmit/receive mode register is set to "1."

The operation of the sleep mode for an 8-bit asynchronous communication is described below.

When sleep mode is selected, the contents of the receive register is not transferred to the receive buffer register if bit 7 (bit 6 if 7-bit asynchronous communication and bit 8 if 9-bit asynchronous communication) of the received data is "0". Also the Rli, OERi, FERi, PERi, and the SUMi flags are unchanged. Therefore, the interrupt request bit of the UARTi receive interrupt control register is also unchanged. Normal receive operation takes place when bit 7 of the received data is "1".

The following is an example of how the sleep mode can be used.

The main microcomputer first sends data: bit 7 is "1" and bits 0 to 6 are set to the address of the subordinate microcomputer to be communicated with. Then all subordinate microcomputers receive this data. Each subordinate microcomputer checks the received data, clears the sleep bit to "0" if bits 0 to 6 are its own address and sets the sleep bit to "1" if not. Next, the main microcomputer sends data with bit 7 cleared. Then the microcomputer which cleared the sleep bit will receive the data, but the microcomputers which set the sleep bit to "1" will not. In this way, the main microcomputer is able to communicate only with the designated microcomputer.

## Precautions for clock asynchronous (UART) serial communication

When using pin CTS<sub>0</sub>/RTS<sub>0</sub>, be sure to clear the D-A2 output enable bit (bit 2 at address 9616) to "0" (output disabled). Also, when CTS<sub>i</sub> and RTS<sub>i</sub> are separated, pin CLK<sub>i</sub> cannot be used. Therefore, when CTS<sub>i</sub> and RTS<sub>i</sub> are separated in UART mode, be sure to select an internal clock.

Before transmit operation is performed, be sure to clear bits 2 and 3 of the serial I/O pin control register (address AC16) to "00".

---

MITSUBISHI MICROCOMPUTERS

# M37902FCCHP, M37902FGCHP, M37902FJCHP

SINGLE-CHIP 16-BIT CMOS MICROCOMPUTER

## A-D CONVERTER

The A-D converter is a 10-bit successive approximation converter. Figure 77 shows the block diagram of the A-D converter, Figure 78 shows the bit configuration of the A-D control register 0 (address 1E16), and Figure 79 shows the bit configuration of the A-D control register 1 (address 1F16).

### A-D conversion accuracy

Bit 3 of A-D control register 1 is used to select whether to regard the conversion result as 10-bit or as 8-bit data. The conversion result is regarded as 10-bit data when bit 3 is "1" and as 8-bit data when bit 3 is "0".

When the conversion result is used as 10-bit data, the low-order 8 bits of the conversion result is stored in the even address of the corresponding A-D register and the high-order 2 bits are stored in bits 0 and 1 at the odd address of the corresponding A-D register. Bits 2 to 7 of the A-D register odd address are "000002" when read.

When the conversion result is used as 8-bit data, the conversion result are stored in even address of the corresponding A-D register. In this case, the value at the A-D register's odd address is "0016" when read.

### A-D conversion frequency

An operation clock ( $\phi_{AD}$ ) of an A-D converter can be selected with bit 7 of the A-D control register 0 and bit 4 of the A-D control register 1. When bit 4 of the A-D control register 1 is "0",  $\phi_{AD}$  becomes  $f_2/4$  when bit 7 of the A-D control register 0 is "0",  $\phi_{AD}$  becomes  $f_2/2$  when bit 7 of the A-D control register 0 is "1".

When bit 4 of the A-D control register 1 is "1",  $\phi_{AD}$  becomes  $f_2$  when bit 7 of the A-D control register 0 is "0",  $\phi_{AD}$  becomes  $f_1$  when bit 7 of the A-D control register 0 is "1". Note that  $\phi_{AD} = f_1$  (in other words, the fastest speed) can be selected only in the 8-bit mode.

$\phi_{AD}$  during A-D conversion must be 250 kHz or more because the comparator uses a capacity coupling amplifier.

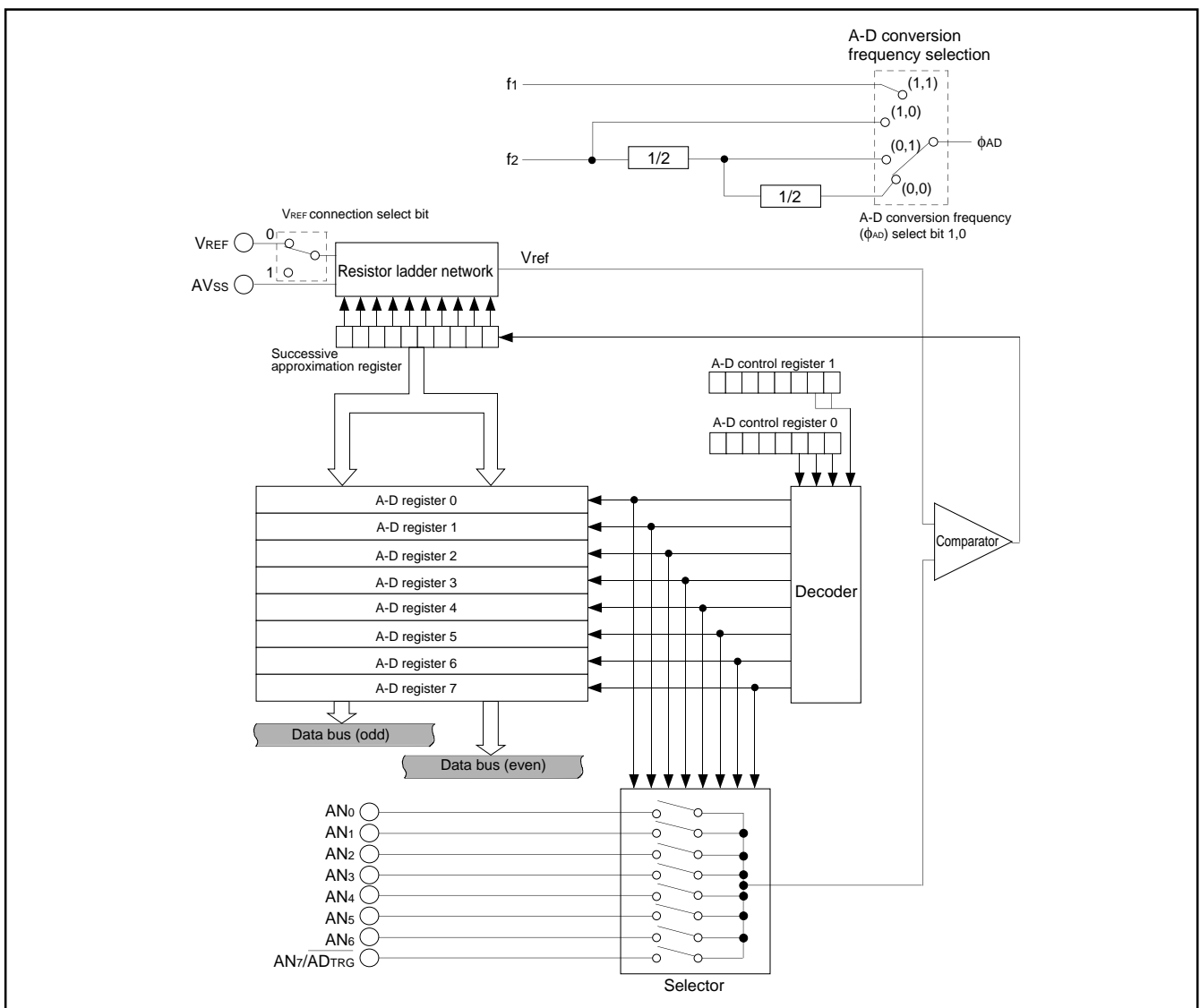

Fig. 77 Block diagram of A-D converter

MITSUBISHI MICROCOMPUTERS

# M37902FCCHP, M37902FGCHP, M37902FJCHP

SINGLE-CHIP 16-BIT CMOS MICROCOMPUTER

## Trigger

A-D conversion can be started by an internal trigger or by an external trigger.

An internal trigger is selected when bit 5 of A-D control register 0 is "0" and an external trigger is selected when it is "1". When trigger is selected, A-D conversion is started when bit 6 (A-D conversion start bit) is set to "1."

When an external trigger is selected, the polarity of a trigger input can be selected by bit 5 of the A-D control register 1. When bit 5 = "0", a falling edge is selected, and when bit 5 = "1", a rising edge is selected.

A-D conversion starts when the A-D conversion start bit is "1" and the  $\overline{ADTRG}$  input changes from "H" to "L" (or "L" to "H.") In this case, the pins that can be used for A-D conversion are AN<sub>0</sub> to AN<sub>6</sub> because the  $\overline{ADTRG}$  pin is multiplexed with an analog voltage input pin, AN<sub>7</sub>. If an

external trigger is selected, even when the A-D conversion is completed, the A-D conversion start bit keeps "1". Also, a retrigger can be available even when A-D conversion is in progress.

## VREF connection

Whether to connect the reference voltage input (VREF) with the resistor ladder network or not depends on bit 6 of the A-D control register 1. The VREF pin is connected when bit 6 is "0" and is disconnected when bit 6 is "1" (High impedance state).

When A-D conversion is not performed, current from the VREF pin to the resistor ladder network can be cut off by disconnecting resistor ladder network from the VREF pin.

Before starting A-D conversion, wait for 1  $\mu$ s or more after clearing bit 6 to "0".

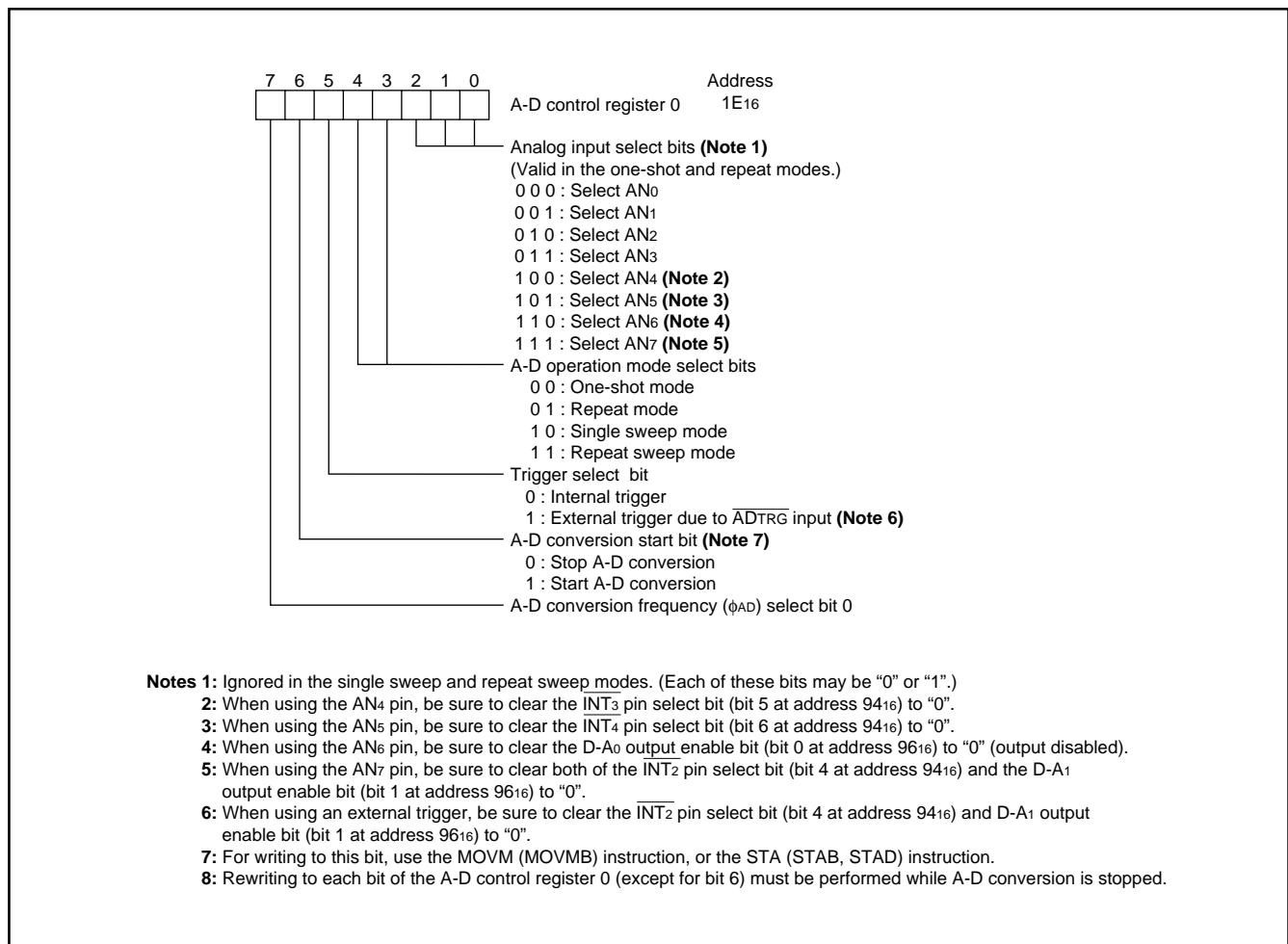
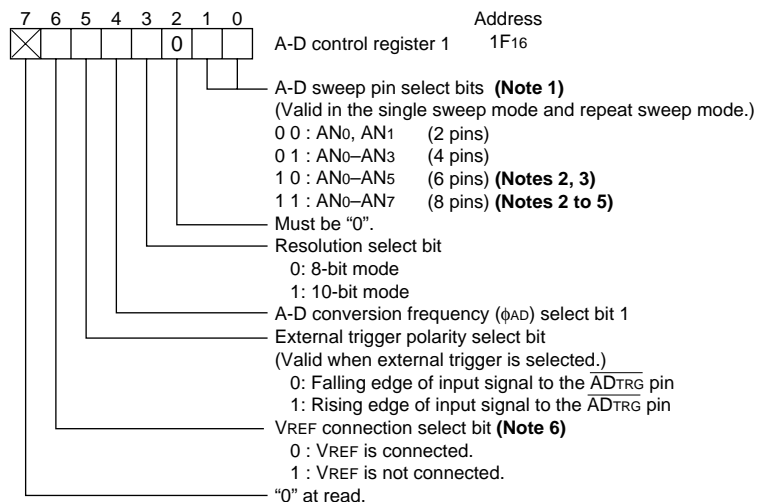

Fig. 78 Bit configuration of A-D control register 0

MITSUBISHI MICROCOMPUTERS

# M37902FCCHP, M37902FGCHP, M37902FJCHP

SINGLE-CHIP 16-BIT CMOS MICROCOMPUTER



A-D conversion frequency ( $\phi_{AD}$ ) select bit		$\phi_{AD}$
Bit 1	Bit 0	
0	0	$f_2/4$
0	1	$f_2/2$
1	0	$f_2$
1	1	$f_1$ (Selectable only in 8-bit mode)

- Notes 1:** Ignored in the one-shot and repeat modes. (Each of these bits may be "0" or "1".)
- 2:** When using the AN<sub>4</sub> pin, be sure to clear the  $\overline{INT}_3$  pin select bit (bit 5 at address 94<sub>16</sub>) to "0".
- 3:** When using the AN<sub>5</sub> pin, be sure to clear the  $\overline{INT}_4$  pin select bit (bit 6 at address 94<sub>16</sub>) to "0".
- 4:** When using the AN<sub>6</sub> pin, be sure to clear the D-A<sub>0</sub> output enable bit (bit 0 at address 96<sub>16</sub>) to "0" (output disabled).
- 5:** When using the AN<sub>7</sub> pin, be sure to clear both of the  $\overline{INT}_2$  pin select bit (bit 4 at address 94<sub>16</sub>) and the D-A<sub>1</sub> output enable bit (bit 1 at address 96<sub>16</sub>) to "0". When an external trigger is selected, the AN<sub>7</sub> pin cannot be used as an analog input pin.
- 6:** Once this bit is cleared from "1" to "0", it is necessary to wait for 1  $\mu$ s or more before the A-D or D-A conversion starts.
- 7:** Rewriting to each bit of the A-D control register 1 must be performed while A-D conversion is stopped.

Fig. 79 Bit configuration of A-D control register 1

MITSUBISHI MICROCOMPUTERS

# M37902FCCHP, M37902FGCHP, M37902FJCHP

SINGLE-CHIP 16-BIT CMOS MICROCOMPUTER

---

## Operation mode

The operation mode is selected by bits 3 and 4 of A-D control register 0. The available operation modes are one-shot, repeat, single sweep, and repeat sweep. Analog input port pins are multiplexed with port P7 pins. Therefore, bits which correspond to pins for A-D conversion must be "0" (input mode).

### (1) One-shot mode

One-shot mode is selected when bits 3 and 4 of A-D control register 0 are "0" is "0". The A-D conversion pins are selected with bits 0 to 2 of A-D control register 0. A-D conversion can be started by a software trigger or by an external trigger.

When an internal trigger is selected, A-D conversion is started when bit 6 (A-D conversion start bit) is set to "1."

When bit 3 of the A-D control register 1 is "1", A-D conversion ends after 59  $\phi_{AD}$  cycles, and the interrupt request bit of the A-D interrupt control register is set to "1." At the same time, A-D control register 0 bit 6 (A-D conversion start bit) is cleared to "0" and A-D conversion stops. The result of A-D conversion is stored in the A-D register corresponding to the selected pin.

If an external trigger is selected, A-D conversion starts when the A-D conversion start bit is "1" and a valid edge is input to the  $\overline{ADTRG}$  pin. This operation is the same as that for internal trigger except that the A-D conversion start bit is not cleared after A-D conversion and a retrigger can be available during A-D conversion.

### (2) Repeat mode

Repeat mode is selected when bit 3 of A-D control register 0 is "1" and bit 4 is "0".

The operation of this mode is the same as the operation of one-shot mode except that when A-D conversion of the selected pin is complete and the result is stored in the A-D register, conversion does not stop, but is repeated.

No interrupt request is generated in this mode. Furthermore, if an external trigger is selected, the A-D conversion start bit is not cleared.

The contents of the A-D register can be read at any time.

### (3) Single sweep mode

Single sweep mode is selected when bit 3 of A-D control register 0 is "0" and bit 4 is "1".

In the single sweep mode, the number of analog input pins to be swept can be selected. Analog input pins are selected by bits 1 and 0 of the A-D control register 1 (address 1F16). Two pins, four pins, six pins, or eight pins can be selected as analog input pins, depending on the contents of these bits.

A-D conversion is performed only for selected input pins. After A-D conversion is performed for input of AN0 pin, the conversion result is stored in A-D register 0, and in the same way, A-D conversion is performed for selected pins one after another. After A-D conversion is performed for all selected pins, the sweep is stopped.

A-D conversion can be started with an internal trigger or with an external trigger input. An internal trigger is selected when bit 5 of the A-D control register 0 (address 1E16) is "0" and an external trigger is selected when it is "1".

When an internal trigger is selected, A-D conversion is started when A-D control register 0 bit 6. (A-D conversion start bit) is set to "1."

When A-D conversion of all selected pins end, the interrupt request bit of the A-D conversion interrupt control register is set to "1." At the same time, A-D conversion start bit is cleared to "0" and A-D conversion stops.

When an external trigger is selected, A-D conversion starts when the A-D conversion start bit is "1" and a valid edge is input to the  $\overline{ADTRG}$  pin. In this case, the A-D conversion result which is stored in the A-D register 7 becomes invalid.

The operation by external trigger is the same as that by an internal trigger except that the A-D conversion start bit is not cleared to "0" after A-D conversion and a retrigger can be available during A-D conversion.

### (4) Repeat sweep mode

Repeat sweep mode is selected when bit 3 of A-D control register 0 is "1" and bit 4 is "1".

The difference from the single sweep mode is that A-D conversion does not stop after conversion for all selected pins, but repeats again from the AN0 pin. The repeat is performed among the selected pins. Also, no interrupt request is generated. Furthermore, if an internal trigger is selected, the A-D conversion start bit is not cleared. The A-D register can be read at any time.

## Precautions for A-D conversion interrupt function

Clear the interrupt request bit of the A-D interrupt control register (bit 3 at address 7016) before using the A-D interrupt. It is because the interrupt request bit is undefined just after reset.

MITSUBISHI MICROCOMPUTERS

# M37902FCCHP, M37902FGCHP, M37902FJCHP

SINGLE-CHIP 16-BIT CMOS MICROCOMPUTER

## D-A CONVERTER

Three independent D-A converters are included in this microcomputer, and each D-A converter adopts an 8-bit R-2R method. Figure 80 shows the block diagram of the D-A converter, Figure 81 shows the bit configuration of the A-D control register 1, and Figure 82 shows the bit configuration of the D-A control register.

D-A conversion is performed by writing a value to the corresponding D-A register *i*. Whether to output the analog voltage or not is determined by bits 0 to 2 of the D-A control register. When any of bits 0 to 2 = "1", the corresponding pin (D-A<sub>0</sub> to D-A<sub>2</sub>) outputs the analog voltage.

This analog voltage (*V*) is determined according to value *n*. ("n" = decimal number. This has been set in the D-A register.)

$$V = V_{REF} \times n/256 \quad (n = 0 \text{ to } 255)$$

*V*<sub>REF</sub> : Reference voltage

The contents of the corresponding D-A output enable bit and D-A register are cleared to "0" at reset. Whether to connect the reference voltage input (*V*<sub>REF</sub>) with the ladder network or not depends on bit 6 of the A-D control register 1. Pin *V*<sub>REF</sub> is connected with the ladder network when bit 6 = "0" and is disconnected when bit 6 = "1" (high impedance state). When not performing the A-D or D-A conversion, current from pin *V*<sub>REF</sub> to the ladder network can be cut off by disconnecting ladder network from pin *V*<sub>REF</sub>.

Before starting A-D or D-A conversion, be sure to clear bit 6 to "0", and then, insert a waiting time of 1 μs or more.

An external buffer is necessary when connecting a low impedance load with the D-A converter. It is because that a D-A output pin doesn't include a buffer.

Pin D-A<sub>*i*</sub> is multiplexed with I/O port pins, analog input pins, serial I/O pins, and external interrupt input pins. When a D-A<sub>*i*</sub> output enable bit = "1" (in other words, output is enabled.), however, the corresponding pin cannot function as another I/O pin, which is multiplexed

with pin D-A<sub>*i*</sub>.

Also, when not using the D-A converter, be sure to clear the contents of the corresponding D-A output enable bit and D-A register to "0".

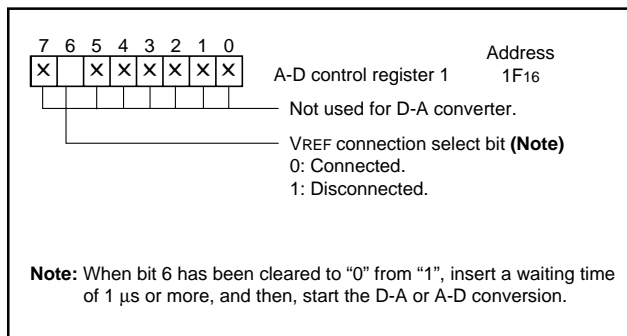

Fig. 81 Bit configuration of A-D control register 1

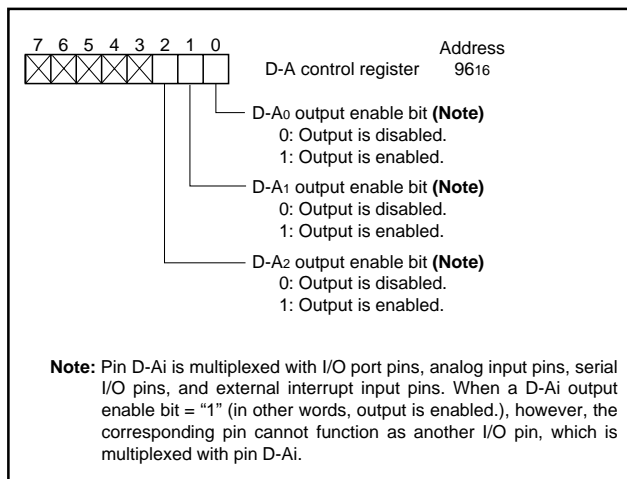

Fig. 82 Bit configuration of D-A control register

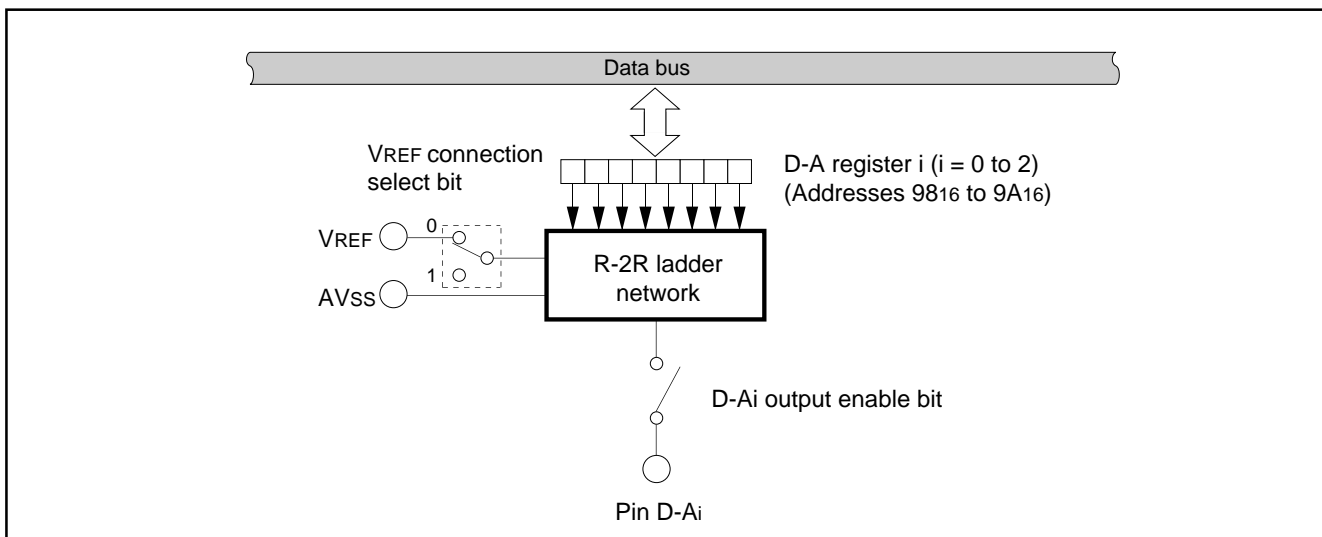

Fig. 80 Block diagram of D-A converter



# MITSUBISHI MICROCOMPUTERS

## M37902FCCHP, M37902FGCHP, M37902FJCHP

SINGLE-CHIP 16-BIT CMOS MICROCOMPUTER

### REAL-TIME OUTPUT

The real-time output function enables to change the output level of several pins simultaneously with a specified timer's counting.

Whether to use the real-time output function is decided by the waveform output select bits of the 8-bit real-time output control register (bits 0 and 1 at address A016). (See Figure 83.) Also, the real-time output controlled by the pulse output mode select bit of the real-time output control register (bit 2 at address A016) and is used in one of the following ways:

- 4 bits X 2 channels
- 6 bits X 1 channel + 2 bits X 1 channels

#### (1) Pulse mode 0

When the pulse output mode select bit is cleared to "0", the micro-computer enters pulse output port is controlled by 2 groups of 4 bits. Figures 84 and 85 show the bit configuration of the pulse output data register 0/1 (address A216/A416) and real-time output structure in pulse mode 0, respectively.

When the waveform output select bits are set to "01" (bit 1 = "0" and bit 0 = "1"), RTP03 to RTP00 become pulse output port pins, in other words, RTP0 is selected.

When the waveform output select bits are set to "10" (bit 1 = "1" and bit 0 = "0"), RTP13 to RTP10 become pulse output port pins, in other words, RTP1 is selected.

When the waveform output select bits are set to "11" (bit 1 = "1" and bit 0 = "1"), two groups consisting of RTP13 to RTP10 and RTP03 to RTP00 become pulse output port pins, in other words, RTP1 and RTP0 are selected.

When the waveform output select bits are set to "00" (bit 1 = bit 0 = "0"), port P5 pins become normal programmable I/O port pins.

The contents of the pulse output data register 1 (high-order 4 bits at address A416), which corresponds to RTP13 to RTP10, is output to these ports each time when the contents of timer A1 counter becomes "000016". The contents of the pulse output data register 0

(low-order 4 bits at address A216), which corresponds to RTP03 to RTP00, is output to these ports each time when the contents of timer A0 counter becomes "000016".

When "0" is written to a specified bit of the pulse output data register, a low-level signal is output to a pulse output port if the counter contents of the timer which corresponds to the bit becomes "000016": when "1" is written to the bit, a high-level signal is output to a pulse output port which corresponds to the bit at the same timing.

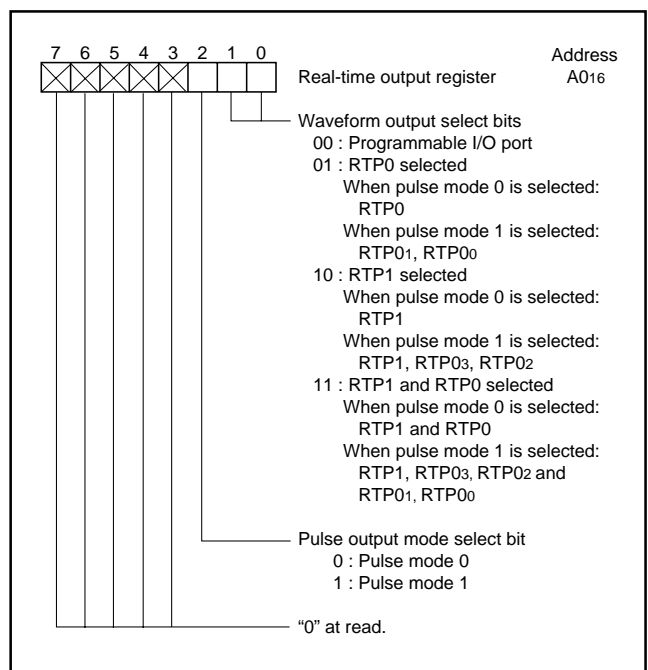

Fig. 83 Bit configuration real-time output control register

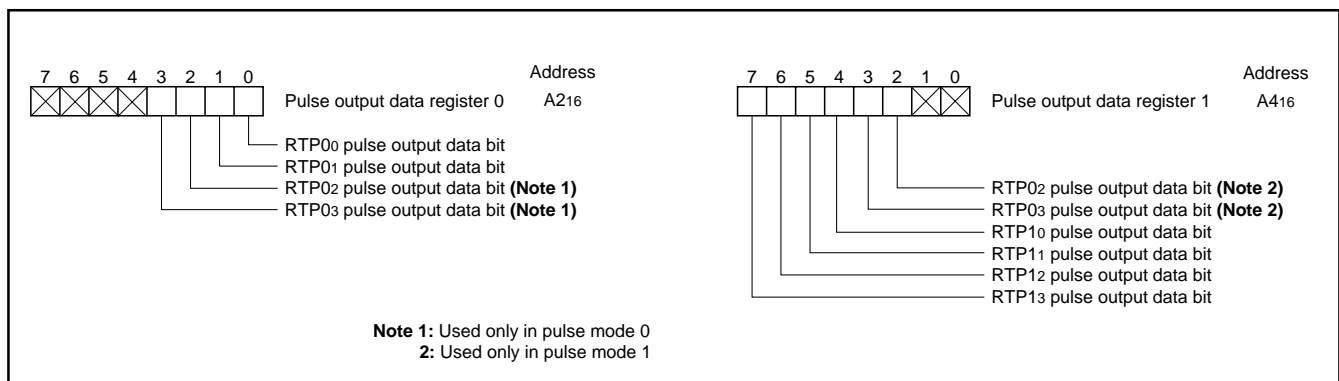

Fig. 84 Bit configuration of pulse output data register

MITSUBISHI MICROCOMPUTERS

# M37902FCCHP, M37902FGCHP, M37902FJCHP

SINGLE-CHIP 16-BIT CMOS MICROCOMPUTER

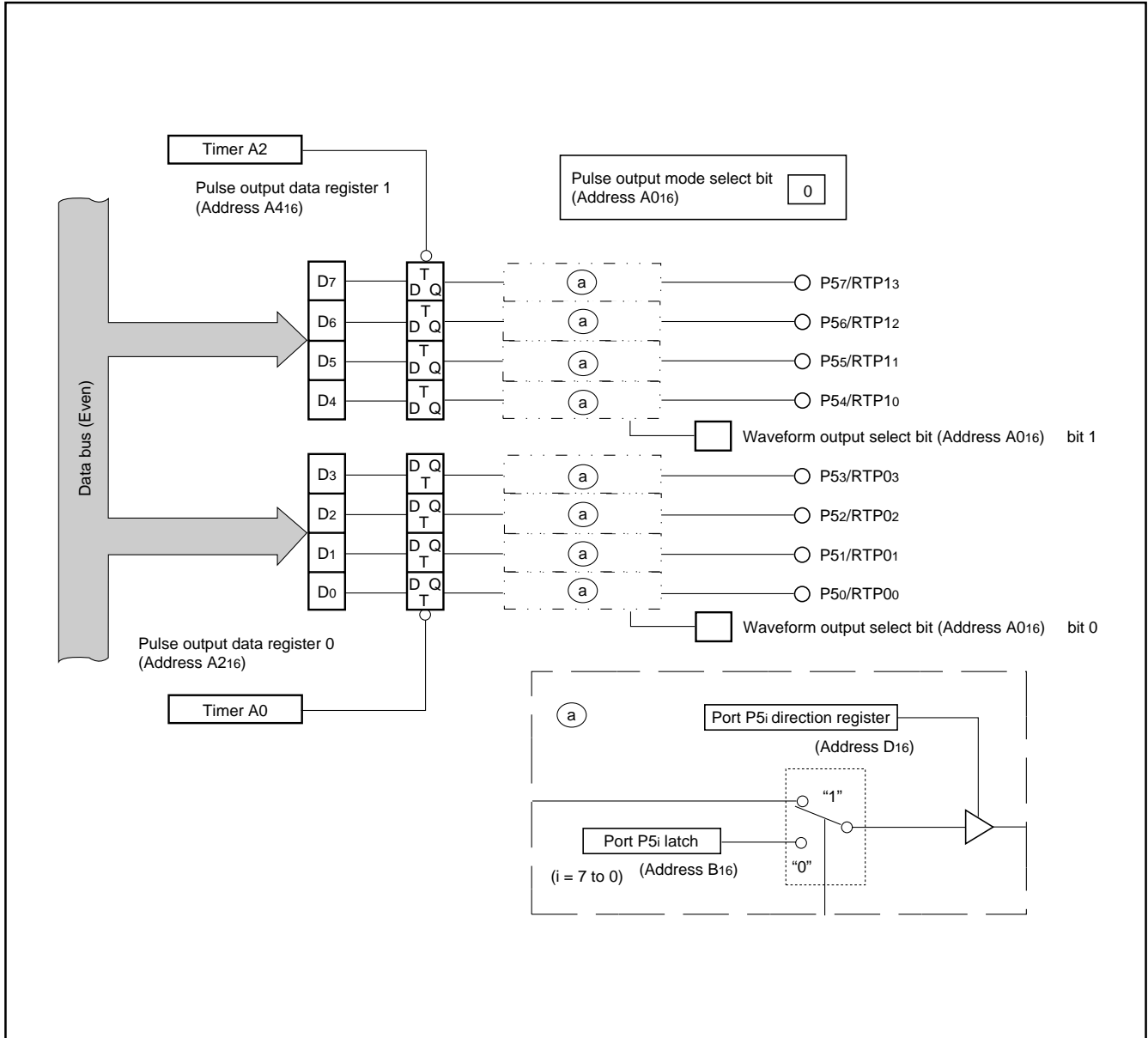

Fig. 85 Real-time output structure in pulse mode 0

## (2) Pulse mode 1

When the pulse output mode select bit is set to "1", the microcomputer enters pulse mode 1, and a pulse output port pins are separately controlled (6 bits and 2 bits).

Figures 86 shows the real-time output structure in pulse mode 1.

When the waveform output select bits are set to "01" (bit 1 = "0" and bit 0 = "1"), RTP13 to RTP10, RTP03, and RTP02 become programmable I/O port pins. Simultaneously, RTP01 and RTP00 become pulse output port pins.

When the waveform output select bits are set to "10" (bit 1 = "1" and bit 0 = "0"), RTP13 to RTP10, RTP03, and RTP02 become pulse output port pins. At this time, RTP01 and RTP00 become programmable I/O port pins.

When the waveform output select bits are set to "11" (bit 1 = bit 0 =

"1"), pulse output port pins are divided into two groups; one consists of RTP13 to RTP10, RTP03, RTP02 and the other consists of RTP01 and RTP00.

When the waveform output select bits are set to "00" (bit 1 = bit 0 = "0"), port P5 pins become normal programmable I/O port pins.

RTP13 to RTP10, RTP03, and RTP02 are controlled by timer A2. Also, RTP01 and RTP00 are controlled by timer A0.

The contents of the pulse output data register 1 (high-order 6 bits at address A416), which corresponds to RTP13 to RTP10, RTP03, and RTP02, are output to this port each time when the contents of timer A2 counter becomes "000016". The contents of the pulse output data register 0 (low-order 2 bits at address A216), which corresponds to RTP01 and RTP00, are output to this port each time when the contents of timer A0 counter become "000016".

# MITSUBISHI MICROCOMPUTERS

## M37902FCCHP, M37902FGCHP, M37902FJCHP

SINGLE-CHIP 16-BIT CMOS MICROCOMPUTER

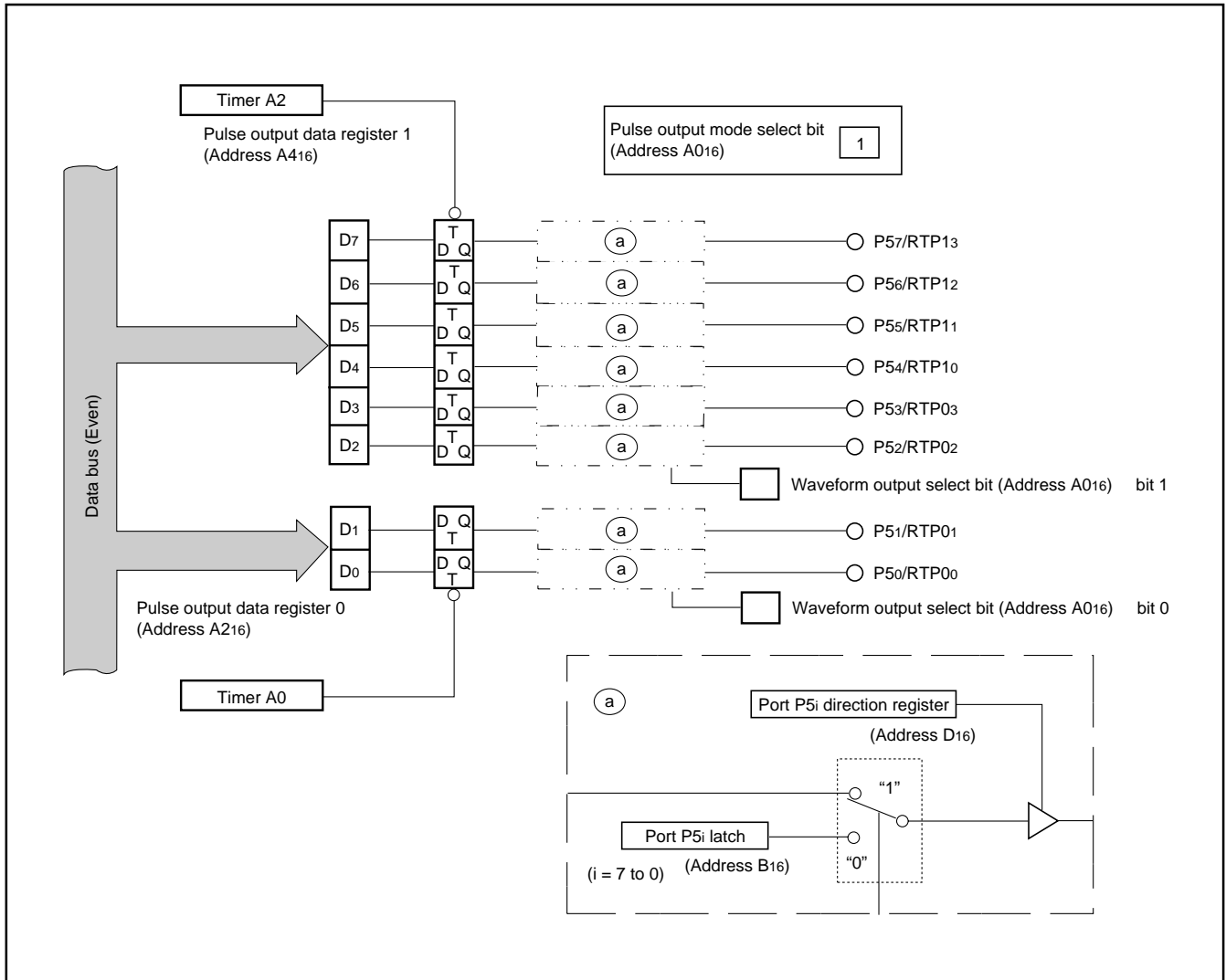

Fig. 86 Real-time output structure in pulse mode 1

Table 14 lists the port P5/RTP pin output when all of the port P5 direction registers are set to the output mode.

### Precautions for real-time output function

After reset, the port P5 direction register is set to the input mode, and port P5i (i = 0 to 7) pins function as normal I/O port pins. When using these pins as real-time output port pins, set the corresponding bits of the port P5 direction register to the output mode. Additionally, by reading the real-time output port's value from the port P5 register, output level of pins can be read out.

Table 14 Port P5/RTP pin output

Real-time output control register (Address A016)			Store address for port P5/RTP pin output data							
bit 2	bit 1	bit 0	bit 7	bit 6	bit 5	bit 4	bit 3	bit 2	bit 1	bit 0
0	0	0	0B	0B	0B	0B	0B	0B	0B	0B
	0	1	0B	0B	0B	0B	A2	A2	A2	A2
	1	0	A4	A4	A4	A4	0B	0B	0B	0B
	1	1	A4	A4	A4	A4	A2	A2	A2	A2
1	0	0	0B	0B	0B	0B	0B	0B	0B	0B
	0	1	0B	0B	0B	0B	0B	0B	A2	A2
	1	0	A4	A4	A4	A4	A4	A4	0B	0B
	1	1	A4	A4	A4	A4	A4	A4	A2	A2

Address 0B16: Port P5

Address A216: Pulse output data register 0

Address A416: Pulse output data register 1

# MITSUBISHI MICROCOMPUTERS

## M37902FCCHP, M37902FGCHP, M37902FJCHP

SINGLE-CHIP 16-BIT CMOS MICROCOMPUTER

### WATCHDOG TIMER

The watchdog timer is used to detect unexpected execution sequence caused by software runaway and others. Figure 87 shows the block diagram of the watchdog timer.

The watchdog timer consists of a 12-bit binary counter.

The watchdog timer counts clock  $Wf_{32}$ , which is obtained by dividing the peripheral devices' clock  $f_2$  by 16; or clock  $Wf_{512}$ , which is obtained by doing it by 256. Bit 0 of the watchdog timer frequency select register (watchdog timer frequency select bit) shown in Figure 88 selects which clock is to be counted.

$Wf_{512}$  is selected when this bit 0 is "0", and  $Wf_{32}$  is selected when bit 0 is "1". Bit 0 is cleared to "0" after reset.

$FFF_{16}$  is set in the watchdog timer when "L" level voltage is applied to pin  $\overline{RESET}$ , STP instruction is executed, data is written to the watchdog timer register (address 6016), or the most significant bit of the watchdog timer becomes "0".

After  $FFF_{16}$  is set in the watchdog timer, when the watchdog timer counts  $Wf_{32}$  or  $Wf_{512}$  by 2048 counts, the most significant bit of watchdog timer becomes "0", the watchdog timer interrupt request bit is set to "1", and  $FFF_{16}$  is set again in the watchdog timer.

In program coding, make sure that data is written in the watchdog timer before the most significant bit of the watchdog timer becomes "0". If this routine is not executed owing to unexpected program execution or others, the most significant bit of the watchdog timer be-

comes "0" and an interrupt is generated.

The microcomputer can generate a reset pulse by writing "1" to bit 6 (software reset bit) of processor mode register 0 in an interrupt routine and can be restarted.

The watchdog timer can also be used to return from the **STP** state, where a clock has stopped its operation owing to the **STP** instruction execution. For details, refer to the sections on the clock generating circuit and standby function.

The watchdog timer stops its operation in the following cases, and at this time, input to the watchdog timer is disabled:

- When the external area is accessed in the hold state
- In the wait mode
- In the stop mode

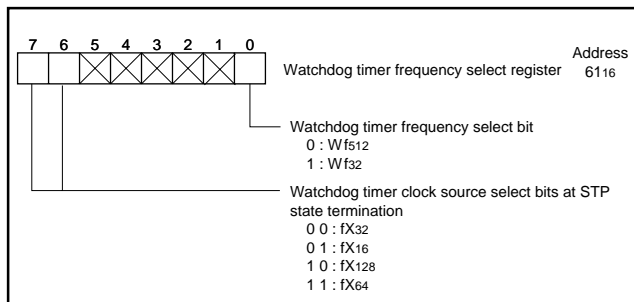

Fig. 88 Bit configuration of watchdog timer frequency select register

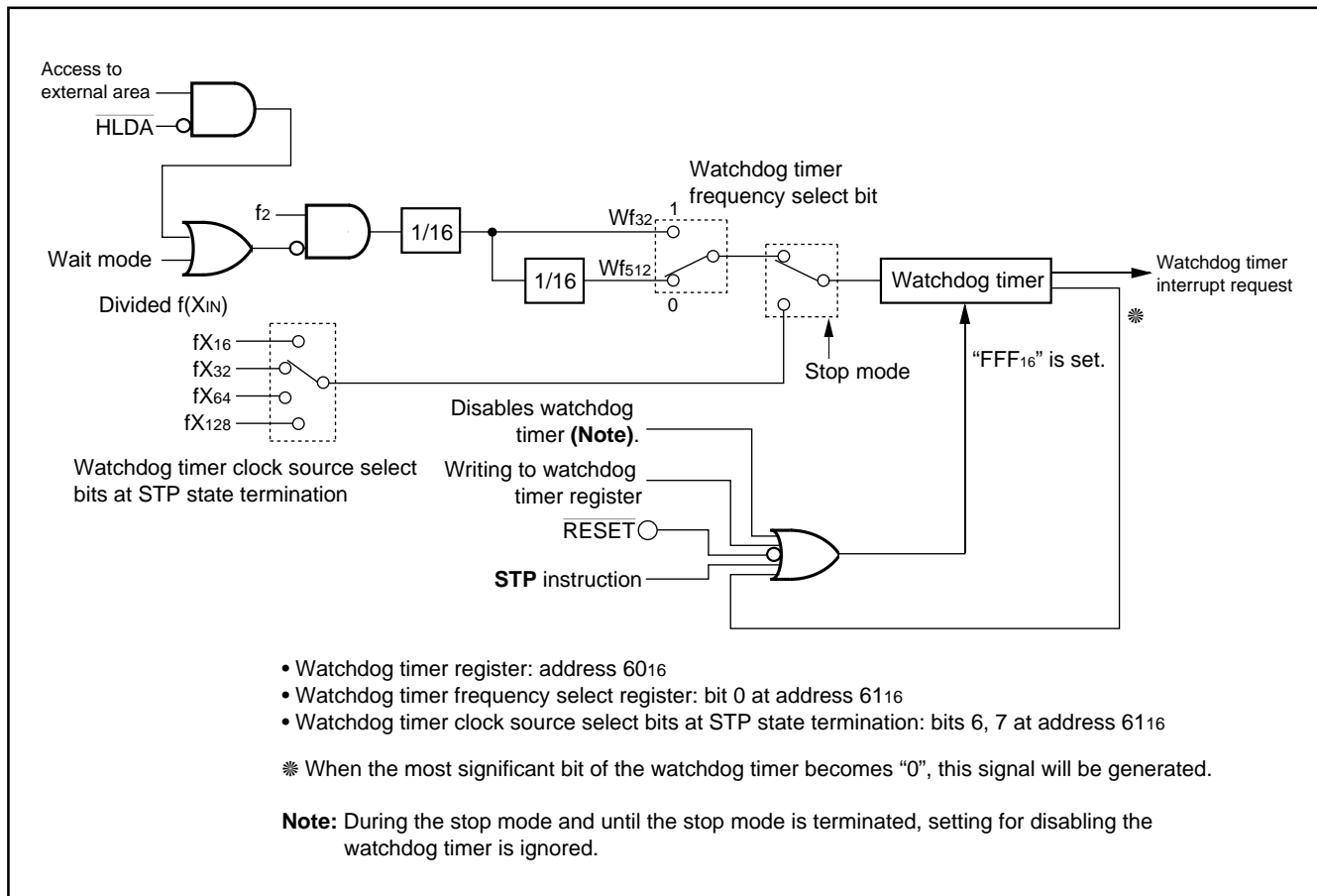

Fig. 87 Block diagram of watchdog timer

MITSUBISHI MICROCOMPUTERS

# M37902FCCHP, M37902FGCHP, M37902FJCHP

SINGLE-CHIP 16-BIT CMOS MICROCOMPUTER

---

## How to disable watchdog timer

When not using the watchdog timer, it can be disabled. When the watchdog timer is disabled, its operation stops and no watchdog timer interrupt has been generated.

Setting for disabling the watchdog timer is possible by writing "79<sub>16</sub>" and "50<sub>16</sub>" to the particular function select register 2 (address 64<sub>16</sub>) sequentially with the following instructions:

- MOVMB/STAB instruction, or
- MOVMB/STA instruction (m = 1)

If any method other than above has been adopted in order to access (in other words, read/write) the particular function select register 2, the watchdog timer will not be disabled until reset operation is performed. (Also, reset is the only one method to remove the setting for disabling the watchdog timer.)

Moreover, this setting for disabling the watchdog timer is ignored at return from the STP mode, and the watchdog timer operates. (For details, refer to the section on the standby function.)

MITSUBISHI MICROCOMPUTERS

# M37902FCCHP, M37902FGCHP, M37902FJCHP

SINGLE-CHIP 16-BIT CMOS MICROCOMPUTER

## INPUT/OUTPUT PINS

Ports P0 to P8, P10, P11 all have the direction register, and each bit can be programmed for input or output. A pin becomes an output pin when the corresponding bit of direction register is "1", and an input pin when it is "0".

When a pin is programmed for output, the data is written to its port latch and it is output to the output pin. When a pin is programmed for output, the contents of the port latch is read instead of the value of the pin. Accordingly, a previously output value can be read correctly even when the output "H" voltage is lowered or the output "L" voltage is raised owing to an external load, etc.

A pin programmed as an input pin is in the floating state, and the value input to the pin can be read. When a pin is programmed as an input pin, the data is written only in the port latch and the pin remains floating.

Each of Figures 89 and 90 shows the block diagram for each port pin and pin  $\overline{NMI}$ . Figure 91 shows the bit configuration of the port function control register.

Bit 3 of the port function control register serves as the port P0 input level select bit, which selects the  $V_{IH}/V_{IL}$  level under the condition that port P0 is used as an input port.

Bit 4 of the port function control register serves as the P44–P47

pullup connection select bit. This bit determines whether port pins P44–P47, which are multiplexed with chip select pins, are to be pulled up or not. At reset, this bit 4 = "0" and P4–P47 are pulled up. The pullup function is valid only when the corresponding port is used as an input port.

Bit 7 of the port function control register serves as the  $\overline{NMI}$  pullup connection select bit. At reset, this bit 7 = "0" and pin  $\overline{NMI}$  is pulled up. The pullup function is valid only when the corresponding port is used as an input port.

When using port pins P54–P57 as the key input interrupt input pins ( $\overline{KI0}$  to  $\overline{KI3}$ ), the pullup function can be selected, also. For details, refer to the section on interrupts.

When using a port pin as an internal peripheral device's input pin, clear the corresponding port direction register's bit to "0". When using a port pin as an internal peripheral device's output pin, the port direction register's bit may be "0" or "1".

In the memory expansion or microprocessor mode, port pins of P0 to P4, P10, P11 become I/O pins, and the their functions as I/O port pins are invalid. Note that, however, some port pins can function as port pins by the special setting. For details, refer to the section on the processor modes.

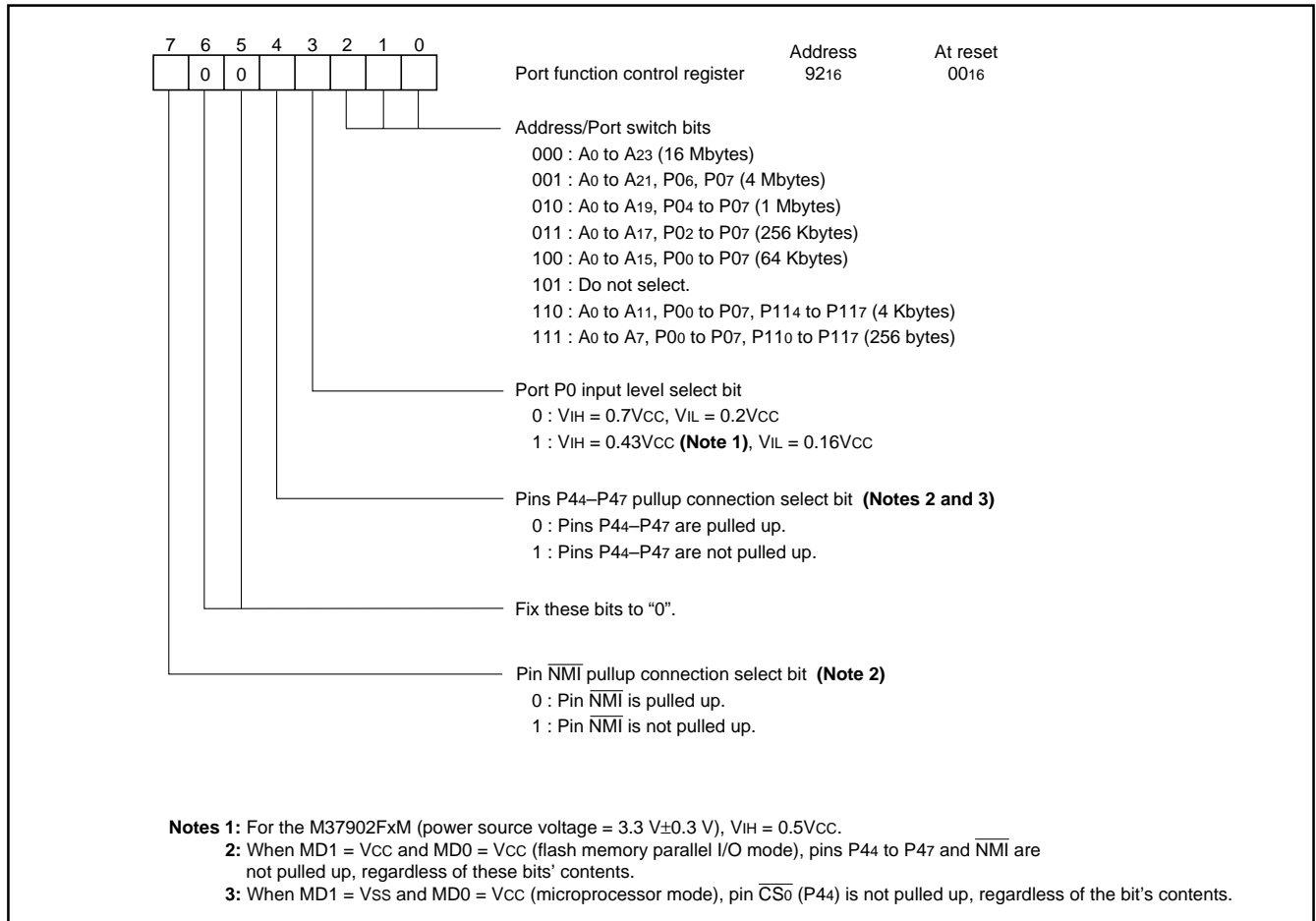

Fig. 91 Bit configuration of port function control register

MITSUBISHI MICROCOMPUTERS  
**M37902FCCHP, M37902FGCHP, M37902FJCHP**

SINGLE-CHIP 16-BIT CMOS MICROCOMPUTER

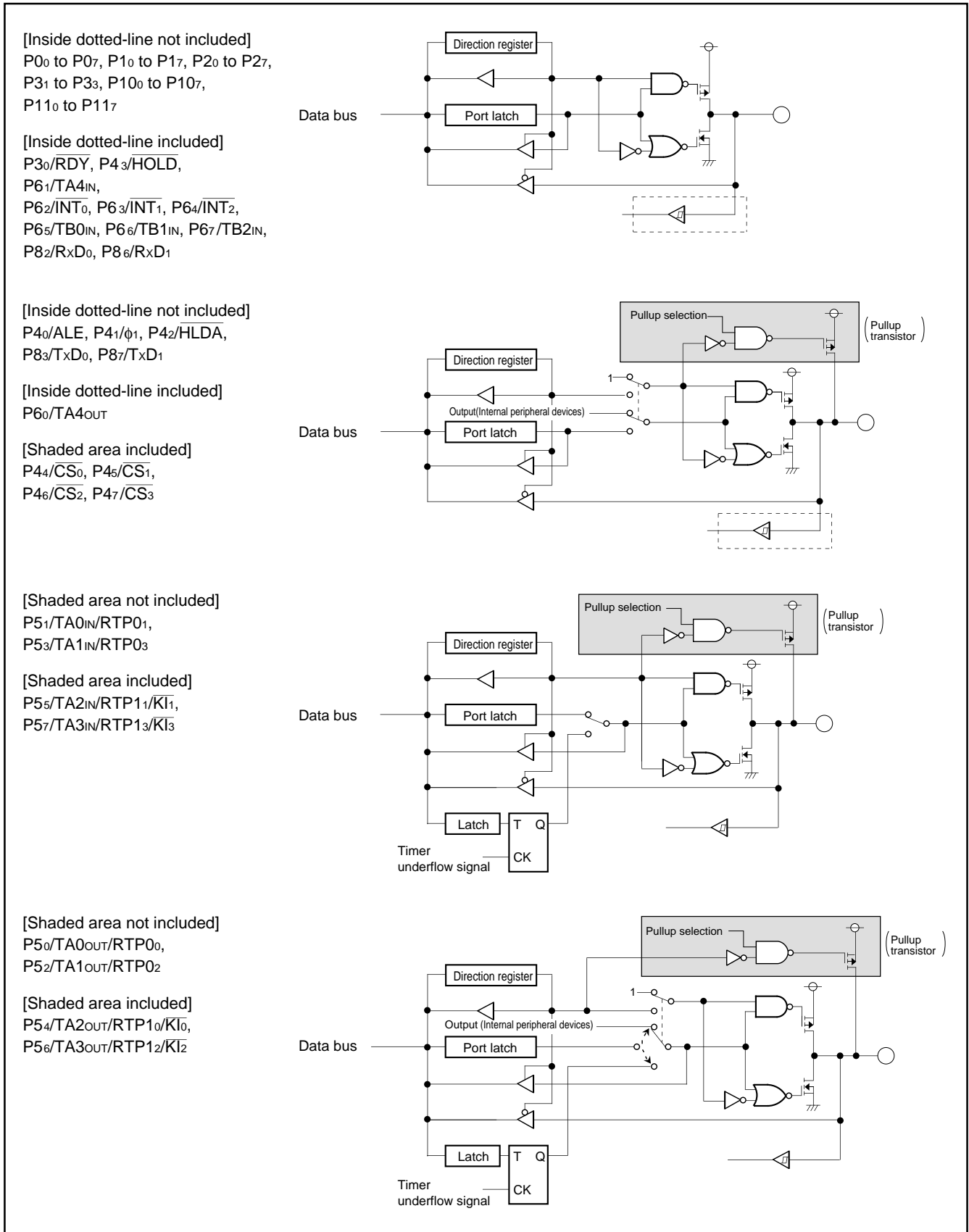

Fig. 89 Block diagram for each port pin and pin  $\overline{\text{NMI}}$  (1)

MITSUBISHI MICROCOMPUTERS

# M37902FCCHP, M37902FGCHP, M37902FJCHP

SINGLE-CHIP 16-BIT CMOS MICROCOMPUTER

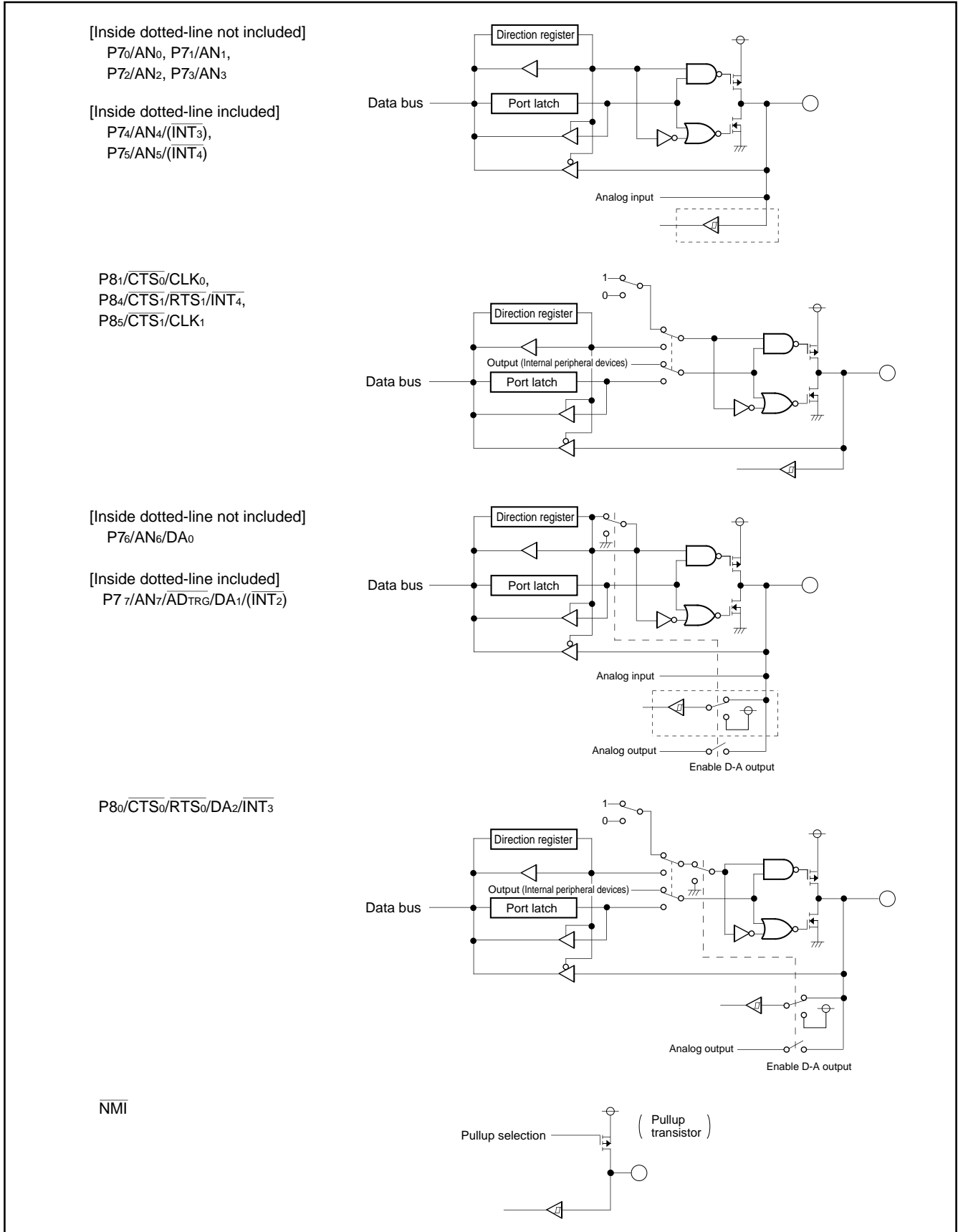

Fig. 90 Block diagram for each port pin and pin  $\overline{\text{NMI}}$  (2)



# MITSUBISHI MICROCOMPUTERS

## M37902FCCHP, M37902FGCHP, M37902FJCHP

SINGLE-CHIP 16-BIT CMOS MICROCOMPUTER

### RESET CIRCUIT

While the power source voltage satisfies the recommended operating condition, reset state is removed if pin  $\overline{\text{RESET}}$ 's level returns from the stabilized "L" level to the "H" level. As a result, program execution starts from the reset vector address. This reset vector address is expressed as shown below:

- A23 to A16 = 0016
- A15 to A8 = Contents at address FFFF16
- A7 to A0 = Contents at address FFFE16

Figures 92 and 93 show the microcomputer internal register's status at reset, and Figure 94 shows an operation example of the reset circuit. Apply "L" level voltage to pin  $\overline{\text{RESET}}$  for a period (2  $\mu\text{s}$  or more) under the following conditions:

- Pin  $V_{\text{CC}}$ 's level satisfies the recommended operating condition.
- Oscillator's operation has been stabilized.

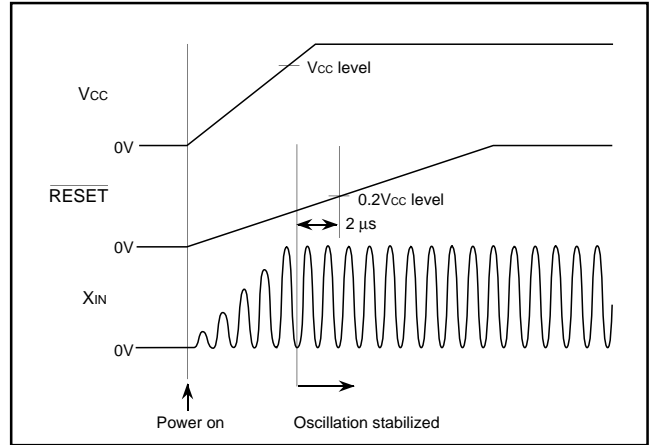

Fig. 94 Operation example of reset circuit (Note that proper evaluation is necessary in the system development stage.)

	Address			
$\overline{\text{CS}}_0$ control register L	(8016)...	Note 2	1 0	Note 3
$\overline{\text{CS}}_0$ control register H	(8116)...	1		0 0 0 1
$\overline{\text{CS}}_1$ control register L	(8216)...	0 1 0	Note 3	1 0
$\overline{\text{CS}}_1$ control register H	(8316)...	0		0 0 0 0
$\overline{\text{CS}}_2$ control register L	(8416)...	0 1 0	Note 3	1 0
$\overline{\text{CS}}_2$ control register H	(8516)...	0		0 0 0 0
$\overline{\text{CS}}_3$ control register L	(8616)...	0 1 0	Note 3	1 0
$\overline{\text{CS}}_3$ control register H	(8716)...			0 0 0 0
Area $\overline{\text{CS}}_0$ start address register	(8A16)...	0 0 0 1	0 0 0 0	
Area $\overline{\text{CS}}_1$ start address register	(8C16)...	0 0 0 0	0 0 0 0	
Area $\overline{\text{CS}}_2$ start address register	(8E16)...	0 0 0 0	0 0 0 0	
Area $\overline{\text{CS}}_3$ start address register	(9016)...	0 0 0 0	0 0 0 0	
Port function control register	(9216)...	0 0 0 0	0 0 0 0	
External interrupt input control register	(9416)...	0 0 0 0	0 0 0 0	
D-A control register	(9616)...		0 0 0	
D-A register 0	(9816)...	0016		
D-A register 1	(9916)...	0016		
D-A register 2	(9A16)...	0016		
Flash memory control register	(9E16)...		0 0 0 0 0 1	
Real-time output control register	(A016)...		0 0 0	
Serial I/O pin control register	(AC16)...		0 0 0 0	
Clock control register	(BC16)...	0 0 0 0	0 1 1 1	
Processor status register PS		0 0 0 ?	0 0 0 1 ? ?	
Program bank register PG		0016		
Program counter PCH		Contents at address FFFF16		
Program counter PCL		Contents at address FFFE16		
Direct page registers DPR0 to DPR3		000016		
Data bank register DT		0016		
Stack pointer		FFF16		

**Notes 1:** The contents of the other registers and RAM are undefined at reset and must be initialized by software.  
**2:** While  $V_{\text{SS}}$  level voltage is applied to pin MD0, this bit is "0". While  $V_{\text{CC}}$  level voltage is applied to pin MD0, on the other hand, this bit is "1".  
**3:** While  $V_{\text{SS}}$  level voltage is applied to pin BYTE, these bits are "0". While  $V_{\text{CC}}$  level voltage is applied to pin BYTE, on the other hand, these bits are "1".

Fig. 93 Microcomputer internal register's status at reset (2)

# MITSUBISHI MICROCOMPUTERS

## M37902FCCHP, M37902FGCHP, M37902FJCHP

SINGLE-CHIP 16-BIT CMOS MICROCOMPUTER

	Address			Address	
Port P0 direction register	(04 <sub>16</sub> )...	00 <sub>16</sub>		Timer B1 mode register	(5C <sub>16</sub> )... 0 0 ? <input checked="" type="checkbox"/> 0 0 0 0
Port P1 direction register	(05 <sub>16</sub> )...	00 <sub>16</sub>		Timer B2 mode register	(5D <sub>16</sub> )... 0 0 ? <input checked="" type="checkbox"/> 0 0 0 0
Port P2 direction register	(08 <sub>16</sub> )...	00 <sub>16</sub>		Processor mode register 0	(5E <sub>16</sub> )... <small>Note 2</small> 0 0 0 0 1 0 <small>Note 2</small> 0
Port P3 direction register	(09 <sub>16</sub> )...	<input checked="" type="checkbox"/> <input checked="" type="checkbox"/> <input checked="" type="checkbox"/> <input checked="" type="checkbox"/> 0 0 0 0		Processor mode register 1	(5F <sub>16</sub> )... 0 0 (Note 2) 0 0
Port P4 direction register	(0C <sub>16</sub> )...	00 <sub>16</sub>		Watchdog timer	(60 <sub>16</sub> )... FFF <sub>16</sub>
Port P5 direction register	(0D <sub>16</sub> )...	00 <sub>16</sub>		Watchdog timer frequency select register	(61 <sub>16</sub> )... 0 0 <input checked="" type="checkbox"/> <input checked="" type="checkbox"/> <input checked="" type="checkbox"/> <input checked="" type="checkbox"/> 0
Port P6 direction register	(10 <sub>16</sub> )...	00 <sub>16</sub>		Particular function select register 0	(62 <sub>16</sub> )... 0 <input checked="" type="checkbox"/> 0 <input checked="" type="checkbox"/> <input checked="" type="checkbox"/> <input checked="" type="checkbox"/> 0 0
Port P7 direction register	(11 <sub>16</sub> )...	00 <sub>16</sub>		Particular function select register 1	(63 <sub>16</sub> )... <input checked="" type="checkbox"/> 0 <input checked="" type="checkbox"/> 0 0 0 0 <small>Note 3</small>
Port P8 direction register	(14 <sub>16</sub> )...	00 <sub>16</sub>		Debug control register 0	(66 <sub>16</sub> )... 1 (Note 3)
Port P10 direction register	(18 <sub>16</sub> )...	00 <sub>16</sub>		Debug control register 1	(67 <sub>16</sub> )... 0 0 0 <small>Note 3</small> 0 0 0 <small>Note 3</small>
Port P10 direction register	(19 <sub>16</sub> )...	00 <sub>16</sub>		$\overline{\text{INT}}_3$ interrupt control register	(6E <sub>16</sub> )... <input checked="" type="checkbox"/> <input checked="" type="checkbox"/> <input checked="" type="checkbox"/> 0 0 0 0
A-D control register 0	(1E <sub>16</sub> )...	0 0 0 0 0 ? ? ?		$\overline{\text{INT}}_4$ interrupt control register	(6F <sub>16</sub> )... <input checked="" type="checkbox"/> <input checked="" type="checkbox"/> <input checked="" type="checkbox"/> 0 0 0 0
A-D control register 1	(1F <sub>16</sub> )...	<input checked="" type="checkbox"/> 0 0 0 0 0 1 1		A-D conversion interrupt control register	(70 <sub>16</sub> )... <input checked="" type="checkbox"/> <input checked="" type="checkbox"/> <input checked="" type="checkbox"/> ? 0 0 0
UART 0 Transmit/Receive mode register	(30 <sub>16</sub> )...	00 <sub>16</sub>		UART 0 transmit interrupt control register	(71 <sub>16</sub> )... <input checked="" type="checkbox"/> <input checked="" type="checkbox"/> <input checked="" type="checkbox"/> 0 0 0 0
UART 1 Transmit/Receive mode register	(38 <sub>16</sub> )...	00 <sub>16</sub>		UART 0 receive interrupt control register	(72 <sub>16</sub> )... <input checked="" type="checkbox"/> <input checked="" type="checkbox"/> <input checked="" type="checkbox"/> 0 0 0 0
UART 0 Transmit/Receive control register 0	(34 <sub>16</sub> )...	0 0 0 0 1 0 0 0		UART 1 transmit interrupt control register	(73 <sub>16</sub> )... <input checked="" type="checkbox"/> <input checked="" type="checkbox"/> <input checked="" type="checkbox"/> 0 0 0 0
UART 1 Transmit/Receive control register 0	(3C <sub>16</sub> )...	0 0 0 0 1 0 0 0		UART 1 receive interrupt control register	(74 <sub>16</sub> )... <input checked="" type="checkbox"/> <input checked="" type="checkbox"/> <input checked="" type="checkbox"/> 0 0 0 0
UART 0 Transmit/Receive control register 1	(35 <sub>16</sub> )...	0 0 0 0 0 0 1 0		Timer A0 interrupt control register	(75 <sub>16</sub> )... <input checked="" type="checkbox"/> <input checked="" type="checkbox"/> <input checked="" type="checkbox"/> 0 0 0 0
UART 1 Transmit/Receive control register 1	(3D <sub>16</sub> )...	0 0 0 0 0 0 1 0		Timer A1 interrupt control register	(76 <sub>16</sub> )... <input checked="" type="checkbox"/> <input checked="" type="checkbox"/> <input checked="" type="checkbox"/> 0 0 0 0
Count start register	(40 <sub>16</sub> )...	00 <sub>16</sub>		Timer A2 interrupt control register	(77 <sub>16</sub> )... <input checked="" type="checkbox"/> <input checked="" type="checkbox"/> <input checked="" type="checkbox"/> 0 0 0 0
One-shot start register	(42 <sub>16</sub> )...	0 <input checked="" type="checkbox"/> <input checked="" type="checkbox"/> 0 0 0 0		Timer A3 interrupt control register	(78 <sub>16</sub> )... <input checked="" type="checkbox"/> <input checked="" type="checkbox"/> <input checked="" type="checkbox"/> 0 0 0 0
Up-down register	(44 <sub>16</sub> )...	00 <sub>16</sub>		Timer A4 interrupt control register	(79 <sub>16</sub> )... <input checked="" type="checkbox"/> <input checked="" type="checkbox"/> <input checked="" type="checkbox"/> 0 0 0 0
Timer A clock frequency select register	(45 <sub>16</sub> )...	<input checked="" type="checkbox"/> <input checked="" type="checkbox"/> <input checked="" type="checkbox"/> <input checked="" type="checkbox"/> <input checked="" type="checkbox"/> 0 0		Timer B0 interrupt control register	(7A <sub>16</sub> )... <input checked="" type="checkbox"/> <input checked="" type="checkbox"/> <input checked="" type="checkbox"/> 0 0 0 0
Timer A0 mode register	(56 <sub>16</sub> )...	00 <sub>16</sub>		Timer B1 interrupt control register	(7B <sub>16</sub> )... <input checked="" type="checkbox"/> <input checked="" type="checkbox"/> <input checked="" type="checkbox"/> 0 0 0 0
Timer A1 mode register	(57 <sub>16</sub> )...	00 <sub>16</sub>		Timer B2 interrupt control register	(7C <sub>16</sub> )... <input checked="" type="checkbox"/> <input checked="" type="checkbox"/> <input checked="" type="checkbox"/> 0 0 0 0
Timer A2 mode register	(58 <sub>16</sub> )...	00 <sub>16</sub>		$\overline{\text{INT}}_0$ interrupt control register	(7D <sub>16</sub> )... <input checked="" type="checkbox"/> 0 0 0 0 0 0
Timer A3 mode register	(59 <sub>16</sub> )...	00 <sub>16</sub>		$\overline{\text{INT}}_1$ interrupt control register	(7E <sub>16</sub> )... <input checked="" type="checkbox"/> 0 0 0 0 0 0
Timer A4 mode register	(5A <sub>16</sub> )...	00 <sub>16</sub>		$\overline{\text{INT}}_2$ interrupt control register	(7F <sub>16</sub> )... <input checked="" type="checkbox"/> 0 0 0 0 0 0
Timer B0 mode register	(5B <sub>16</sub> )...	0 0 ? <input checked="" type="checkbox"/> 0 0 0 0			

**Notes** 1: The contents of the other registers and RAM are undefined at reset and must be initialized by software.  
 2: While V<sub>SS</sub> level voltage is applied to pin MD0, these bits are "0". While V<sub>CC</sub> level voltage is applied to pin MD0, on the other hand, these bits are "1".  
 3: At power-on reset, these bits are clear to "0". At hardware or software reset, on the other hand, these bits retain the value just before reset.

Fig. 92 Microcomputer internal register's status at reset (1)

# MITSUBISHI MICROCOMPUTERS

## M37902FCCHP, M37902FGCHP, M37902FJCHP

SINGLE-CHIP 16-BIT CMOS MICROCOMPUTER

### OSCILLATION CIRCUIT

An oscillation circuit locates between pins XIN and XOUT, and Figure 95 shows a circuit example with a oscillator (an external ceramic resonator or quartz crystal oscillator). The constants such as capacitance etc. depend on a oscillator. Therefore, for these constants, adopt the oscillator manufacturer's recommended values.

Figure 96 shows a circuit example with an external clock source. When an external clock is input, be sure to leave pin XOUT open. Also, in this case, when the external clock input select bit (bit 1 of the particular function select register 0; See Figure 100.) is set to "1", the oscillation circuit stops its operation, and the current dissipation is reduced. Moreover, this bit has another function, which selects the return condition from the stop mode. For details, refer to the section on the standby function.

On the other hand, the PLL (Phase Locked Loop) frequency multiplier (hereafter, referred as PLL circuit.) is included, also. This PLL circuit uses an clock input from pin XIN and generates a multiplied clock. When using the PLL circuit, be sure to connect pin VCONT with an external filter circuit. (See Figure 97.) When not using the PLL circuit, be sure to leave pin VCONT open.

When not using the PLL circuit, be sure to clear the PLL circuit operation enable bit (bit 1 of the clock control register; See Figure 99.), so that the PLL circuit will stop its operation.

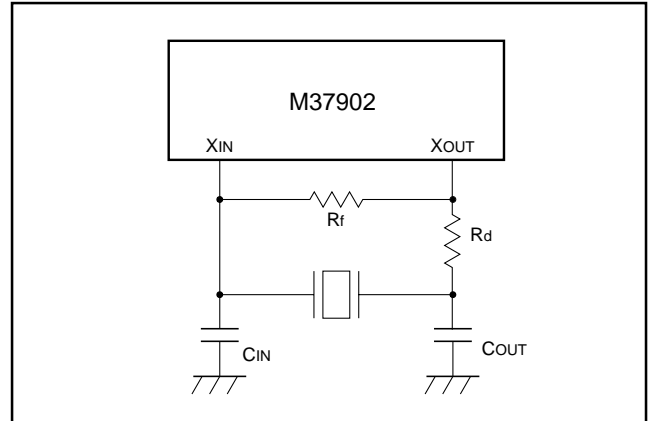

Fig. 95 Circuit example with external ceramic resonator or quartz crystal oscillator

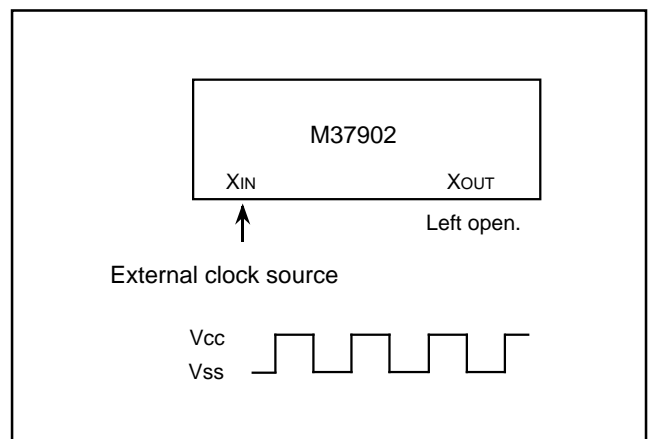

Fig. 96 Circuit example with external clock source

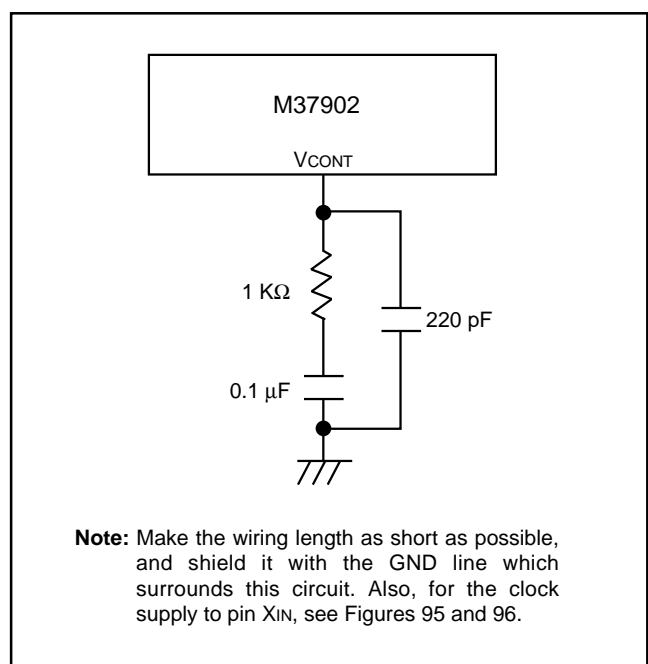

Fig. 97 Circuit example with pin VCONT and PLL circuit

MITSUBISHI MICROCOMPUTERS

# M37902FCCHP, M37902FGCHP, M37902FJCHP

SINGLE-CHIP 16-BIT CMOS MICROCOMPUTER

## CLOCK GENERATING CIRCUIT

Figure 98 shows the block diagram of the clock generating circuit. The clock generating circuit consists of the clock oscillation circuit, PLL frequency multiplier (PLL circuit), system clock switch circuit, peripheral devices' clock switch circuit, clock divider, standby control circuit, etc. As control registers for the clock generating circuit, also, the clock control register (address BC<sub>16</sub>), particular function select register 0 (address 62<sub>16</sub>) are provided. (See Figures 99 and 100.)

As shown in Figure 98, clocks used in the CPU, BIU, peripheral devices, watchdog timer (in other words, clocks  $\phi_{CPU}$ ,  $\phi_{BIU}$ ,  $f_1$  to  $f_{4096}$ ,  $Wf_{32}$ ,  $Wf_{512}$ ) are made from system clock  $f_{sys}$ . System clock  $f_{sys}$  can be selected between  $f_{XIN}$  (in other words, a clock input from pin X<sub>IN</sub>) and  $f_{PLL}$  (in other words, an output clock generated by the PLL circuit). By setting the clock  $\phi_1$  output select bit (bit 7 of the processor mode register 0) to "1", also, system clock  $f_{sys}$  can be output from port pin P41, as clock  $\phi_1$ .

The PLL circuit's operation, system clock ( $f_{sys}$ ) selection, and divide ratio selection for peripheral devices' clocks ( $f_1$  to  $f_{4096}$ ) are controlled by the clock control register. The following describes about these control.

Bit 1 of the clock control register (the PLL circuit operation enable bit) selects the PLL circuit's operation (stopped/active). When this bit is set to "1", pin VCONT will become valid, and the PLL circuit will operate. At reset, the PLL circuit operation enable bit becomes "1". (In this case, the PLL circuit operates.) When not using the PLL circuit, be sure to clear the PLL circuit operation enable bit to "0" (stopped). At the STP instruction execution or while the flash memory parallel I/O mode is set, the PLL circuit stops its operation, and pin VCONT is in-

valid, regardless of this bit 1's status.

Bits 2 and 3 of the clock control register (the PLL multiplication ratio select bits) select the ratio of  $f_{PLL}/f_{XIN}$ . The PLL multiplication ratio must be set so that the frequency of the PLL output clock ( $f_{PLL}$ ) must be in the range from 10 MHz to 26 MHz. At reset, the PLL multiplication ratio select bits become "0,1" (X 2). The change of the multiplication ratio must be performed while input clock  $f_{XIN}$  is set as system clock. (In this case, bit 5 of the clock control register = "0".) After that, be sure to wait that the operation-stabilizing time of the PLL circuit has passed, and switch the system clock to the PLL output clock ( $f_{PLL}$ ). (In other words, set bit 5 to "1".) Note that, after reset, the PLL multiplication ratio select bits are allowed to be changed only once. Bit 5 of the clock control register is the system clock select bit, and  $f_{XIN}$  is selected as the system clock when bit 5 = "0". On the other hand, when bit 5 = "1", the PLL output clock ( $f_{PLL}$ ) is selected. At reset, the system clock select bit becomes "0". When selecting  $f_{PLL}$ , be sure that the PLL circuit's operation has been stabilized properly, and then, set the system clock select bit to "1". Also, when the PLL circuit operation enable bit is cleared to "0" (the PLL circuit is stopped.), the system clock select bit will automatically be cleared to "0". Note that a value of "1" cannot be written to the system clock select bit while the PLL circuit operation enable bit = "0".

Table 15 lists the  $f_{sys}$  selection.

Bits 6 and 7 of the clock control register are the peripheral devices' clock select bits 0, 1, and these bits select the multiplication ratio of ( $f_1$  to  $f_{4096}$ )/( $f_{sys}$ ).

Table 16 lists the internal peripheral devices' operation clock frequency. At reset, these bits become "0, 0".

Table 15.  $f_{sys}$  selection

System clock select bit (Bit 5)	PLL circuit operation enable bit (Bit 1)	PLL multiplication ratio select bits (Bits 3, 2) (Note)	System clock $f_{sys}$	
			Clock source	Frequency (Note)
0	—	—	$f_{XIN}$	$f(XIN)$
1	1	01 (X 2)	$f_{PLL}$	$f(XIN) \times 2$
		10 (X 3)	$f_{PLL}$	$f(XIN) \times 3$
		11 (X 4)	$f_{PLL}$	$f(XIN) \times 4$

**Note:** The PLL multiplication ratio must be set so that the frequency of the PLL output clock ( $f_{PLL}$ ) must be in the range from 10 MHz to 26 MHz.  $f(XIN)$  means the frequency of the input clock from pin X<sub>IN</sub> ( $f_{XIN}$ ). After reset, the PLL multiplication ratio select bits are allowed to be changed only once.

Table 16. Internal peripheral devices' operation clock frequency

Internal peripheral devices' operation clock	Peripheral devices' clock select bits 1, 0 (bits 7, 6)			
	0 0	0 1 (Note)	1 0	1 1
$f_1$	$f_{sys}$	$f_{sys}$	$f_{sys}/2$	Do not select.
$f_2$	$f_{sys}/2$	$f_{sys}$	$f_{sys}/4$	
$f_{16}$	$f_{sys}/16$	$f_{sys}/8$	$f_{sys}/32$	
$f_{64}$	$f_{sys}/64$	$f_{sys}/32$	$f_{sys}/128$	
$f_{512}$	$f_{sys}/512$	$f_{sys}/256$	$f_{sys}/1024$	
$f_{4096}$	$f_{sys}/4096$	$f_{sys}/2048$	$f_{sys}/8192$	

**Note:** When selecting the peripheral devices' clock select bits 1, 0 = "012", be sure that system clock  $f_{sys}$  does not exceed 13 MHz.

M37902FCCHP, M37902FGCHP, M37902FJCHP

SINGLE-CHIP 16-BIT CMOS MICROCOMPUTER

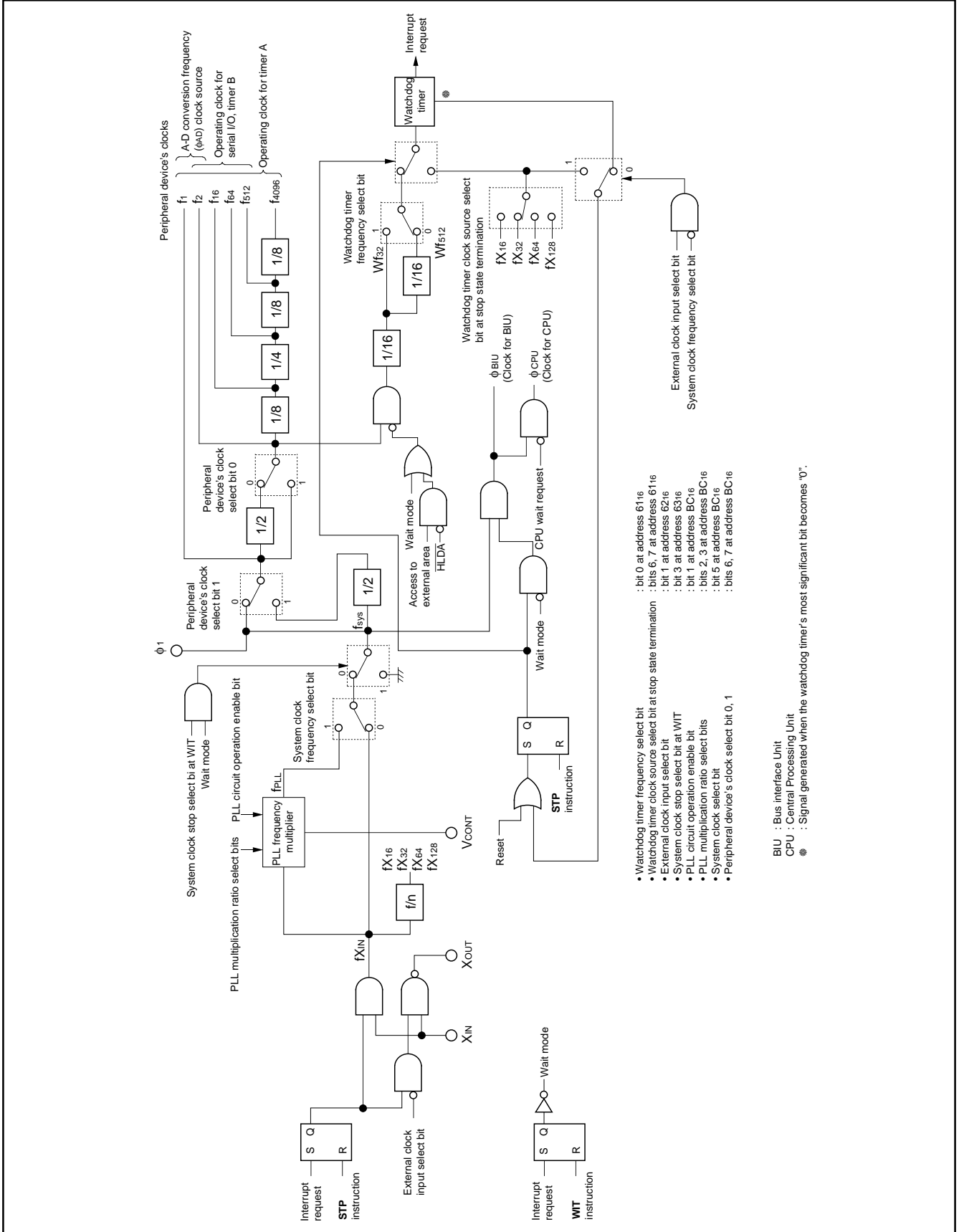

Fig. 98 Block diagram of clock generating circuit

MITSUBISHI MICROCOMPUTERS

# M37902FCCHP, M37902FGCHP, M37902FJCHP

SINGLE-CHIP 16-BIT CMOS MICROCOMPUTER

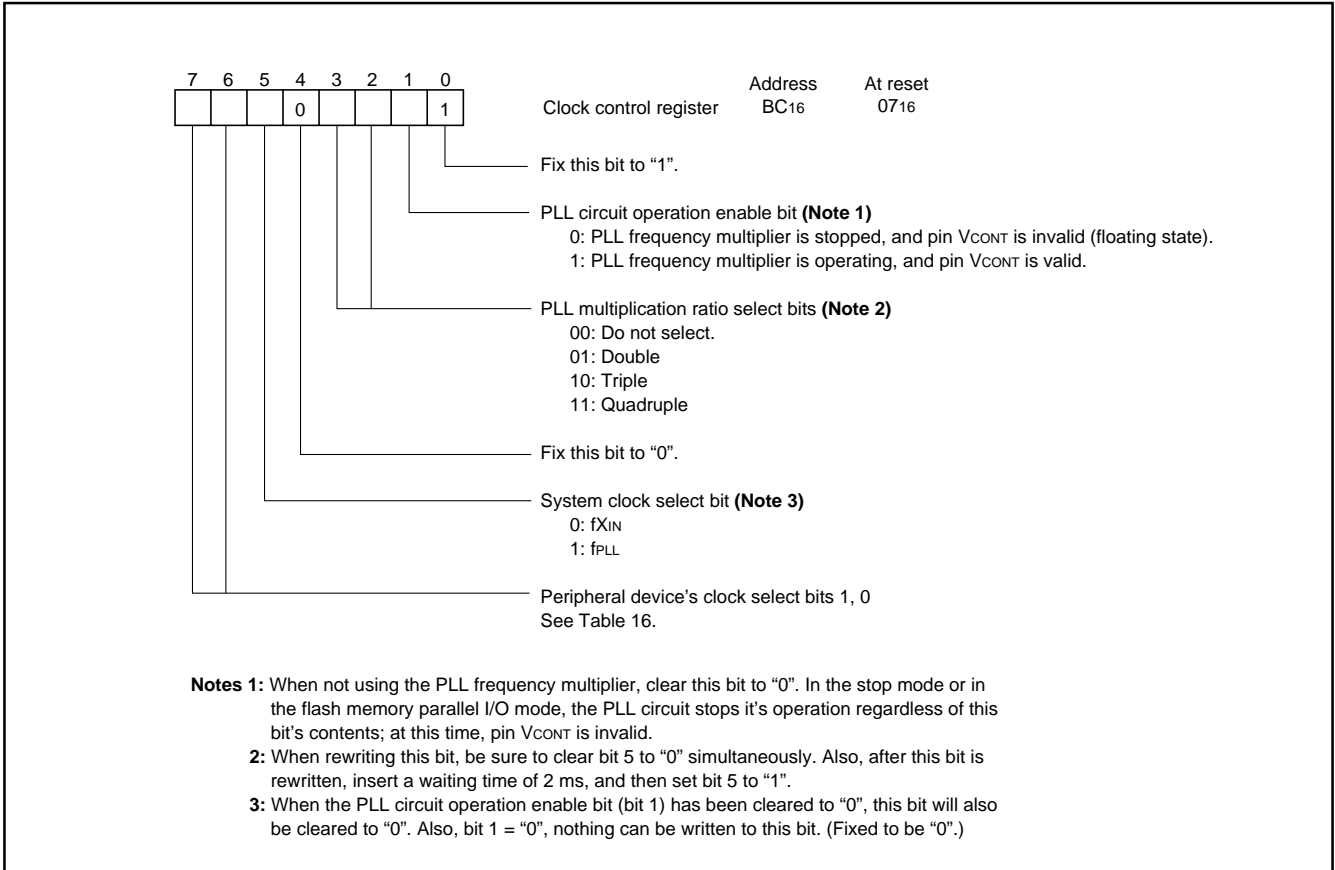

Fig. 99 Bit configuration of clock control register

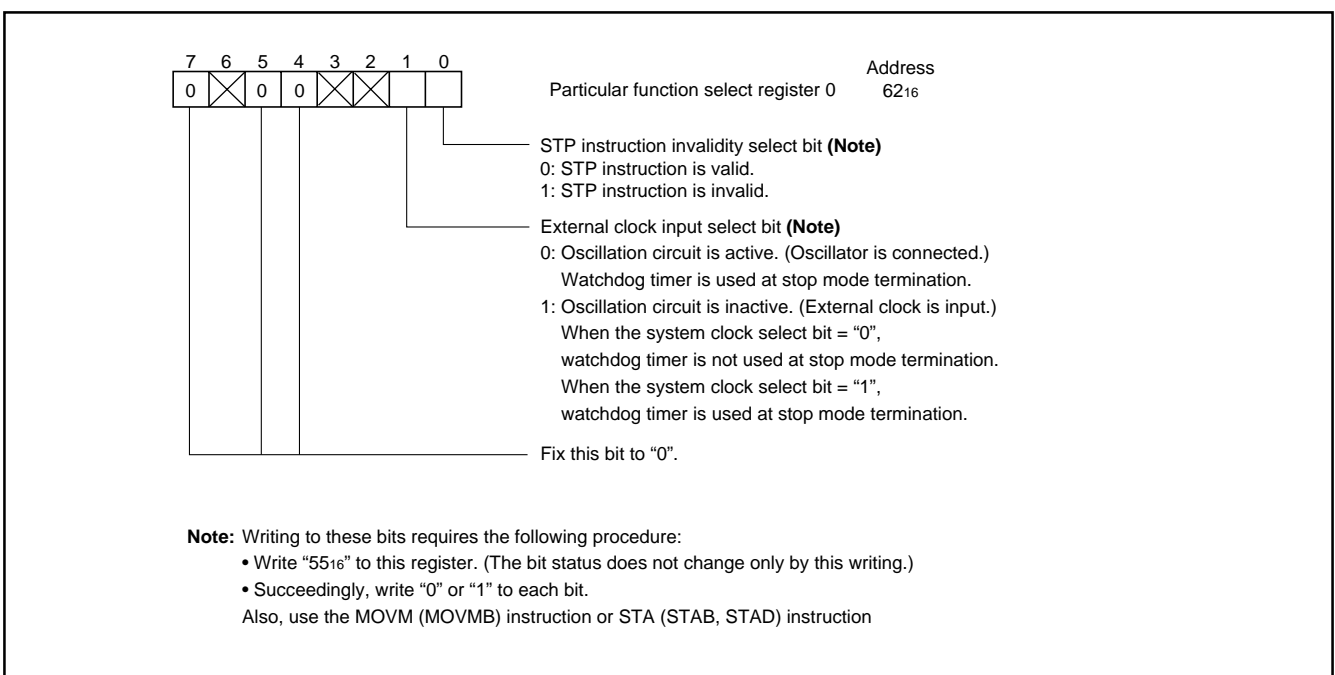

Fig. 100 Bit configuration of particular function select register 0

MITSUBISHI MICROCOMPUTERS

# M37902FCCHP, M37902FGCHP, M37902FJCHP

SINGLE-CHIP 16-BIT CMOS MICROCOMPUTER

## STANDBY FUNCTION

The standby function provides the stop (hereafter called STP) and the wait (hereafter called WIT) mode. These modes are used to save the power dissipation of the system, by stopping oscillation or system clock in the case that the CPU needs not be operating.

The microcomputer enters the STP or WIT mode by executing the STP or WIT instruction, and either mode is terminated by acceptance of an interrupt request or reset.

To terminate the STP or WIT mode by an interrupt request, the interrupt to be used for termination of the STP or WIT mode must be enabled in advance to execution of the STP or WIT instruction. The interrupt priority level of this interrupt is required to be higher than the processor interrupt priority level (IPL) of the routine where the STP or WIT instruction will be executed.

Figures 100 to 102 show the bit configurations of the particular function select registers 0, 1, and watchdog timer frequency select register respectively. Setting the STP instruction invalidity select bit (bit 0 of the particular function select register 0) to "1" invalidates the STP instruction, and the STP instruction will be ignored. Since the above bit is cleared to "0" after reset is removed, however, the STP instruction is valid.

The STP- or the WIT-instruction-execution status bit (bit 0 or 1 of the particular function select register 1) is set to "1" by the execution of the STP or the WIT instruction, and so, after the STP or WIT mode has been terminated, each bit will indicate that the STP or WIT instruction has been executed. Accordingly, each of these bits must be cleared to "0" by software at termination of the STP or the WIT mode. Table 17 explains the microcomputer's operation in the STP and WIT modes.

The external bus fixation function can also be provided. This function enables the user to specify the states of the external bus and the bus control signals in the memory expansion and the microprocessor mode in the STP or WIT mode. For more information, refer to the section on the power saving function.

## STP mode

The execution of the STP instruction stops the oscillation circuit and PLL circuit. It also stops input clock  $f_{XIN}$ , system clock  $f_{sys}$ ,  $\phi_{BIU}$ ,  $\phi_{CPU}$ , and peripheral devices' clocks  $f_1$  to  $f_{4096}$ ,  $Wf_{32}$  and  $Wf_{512}$  in the "L" state, and divide clocks  $f_{X16}$  to  $f_{X128}$  in the "H" state. In the watchdog timer, "FFF16" is automatically set. As shown in Figure 98, any one of divide clocks  $f_{X16}$  to  $f_{X128}$ , which is selected by the watchdog timer clock source select bits at STP termination (bits 6 and 7 of the watchdog timer frequency select register), becomes the watchdog timer's clock source.

In the STP mode, the A-D converter and watchdog timer, which uses peripheral devices' clocks  $f_1$  to  $f_{4096}$ ,  $Wf_{32}$  and  $Wf_{512}$ , are stopped. At this time, timers A and B operate only in the event counter mode, and serial I/O communication is active while an external clock is selected.

The STP mode is terminated by acceptance of an interrupt request or reset, and the oscillation circuit and PLL circuit restart their operations. Input clock  $f_{XIN}$ , system clock  $f_{sys}$ , and peripheral devices' clocks  $f_1$  to  $f_{4096}$ ,  $Wf_{32}$  and  $Wf_{512}$  are also supplied.

When the STP mode is terminated by reset, supply of  $\phi_{BIU}$  and  $\phi_{CPU}$  starts immediately after the oscillation circuit and PLL circuit restart their operations. Therefore, the reset input must be raised "H" after the operation-stabilizing time for these circuits has passed.

The following two modes are available in order to terminate the STP mode by an interrupt:

- (1) The watchdog timer is used in order to measure the period from the operation restart of the oscillation circuit and PLL circuit until the supply start of  $\phi_{BIU}$  and  $\phi_{CPU}$ .
- (2) The supply of  $\phi_{BIU}$  and  $\phi_{CPU}$  is started immediately after the operation restart of the oscillation circuit and PLL circuit.

When the external clock input select bit (bit 1 of the particular function select register 0) = "0" or the system clock select bit (bit 5 of the clock control register) = "1", the watchdog timer will start counting

Table 17. Microcomputer's operation in STP and WIT modes

Mode	System clock stop select bit at WIT	Operations of function while WIT, STP modes					
		Oscillation circuit	PLL circuit	$f_{sys}$ , $\phi_1$ , $f_1$ to $f_{4096}$	$Wf_{32}$ , $Wf_{512}$	$\phi_{BIU}$ , $\phi_{CPU}$	Peripheral devices using $f_1$ to $f_{4096}$ , $Wf_{32}$ , $Wf_{512}$
STP	—	Stopped	Stopped	Stopped ("L")	Stopped ("L")	Stopped ("L")	Timers A, B: Operation is enabled only in the event counter mode. Serial I/O: Operation is enabled only while an external clock is selected. A-D converter: Stopped. (Watchdog timer: Stopped.)
WIT	"0"	Active (Note 1)	Active (Note 2)	Active	Stopped ("L")	Stopped ("L")	Timers A, B, Serial I/O, A-D converter: Operation is enabled. (Watchdog timer: Stopped.)
	"1"	Active (Note 1)	Active (Note 2)	Stopped ("L")	Stopped ("L")	Stopped ("L")	Timers A, B: Operation is enabled only in the event counter mode. Serial I/O: Operation is enabled only while an external clock is selected. A-D converter: Stopped. (Watchdog timer: Stopped.)

**Notes 1:** When the external clock input select bit = "1", the oscillation circuit stops. Also, clock input from pin  $X_{IN}$  is available.

**2:** When the PLL operation enable bit = "0", the PLL circuit stops.

MITSUBISHI MICROCOMPUTERS

# M37902FCCHP, M37902FGCHP, M37902FJCHP

SINGLE-CHIP 16-BIT CMOS MICROCOMPUTER

down with one of the above divide clocks,  $fX_{16}$  to  $fX_{128}$ , after the oscillation circuit and PLL circuit have been restarted their operations owing to an interrupt. The most significant bit of the watchdog timer reaching "0", supply of  $\phi_{BIU}$  and  $\phi_{CPU}$  restarts.

On the other hand, when the external clock input select bit = "1" and the system clock select bit = "0", supply of  $\phi_{BIU}$  and  $\phi_{CPU}$  will restart immediately after the oscillation circuit has been restarted their operations owing to an interrupt. (In actual fact, after the selected one of the above divide clocks,  $fX_{16}$  to  $fX_{128}$ , has been changed from "H" to "L", this supply will restart.)

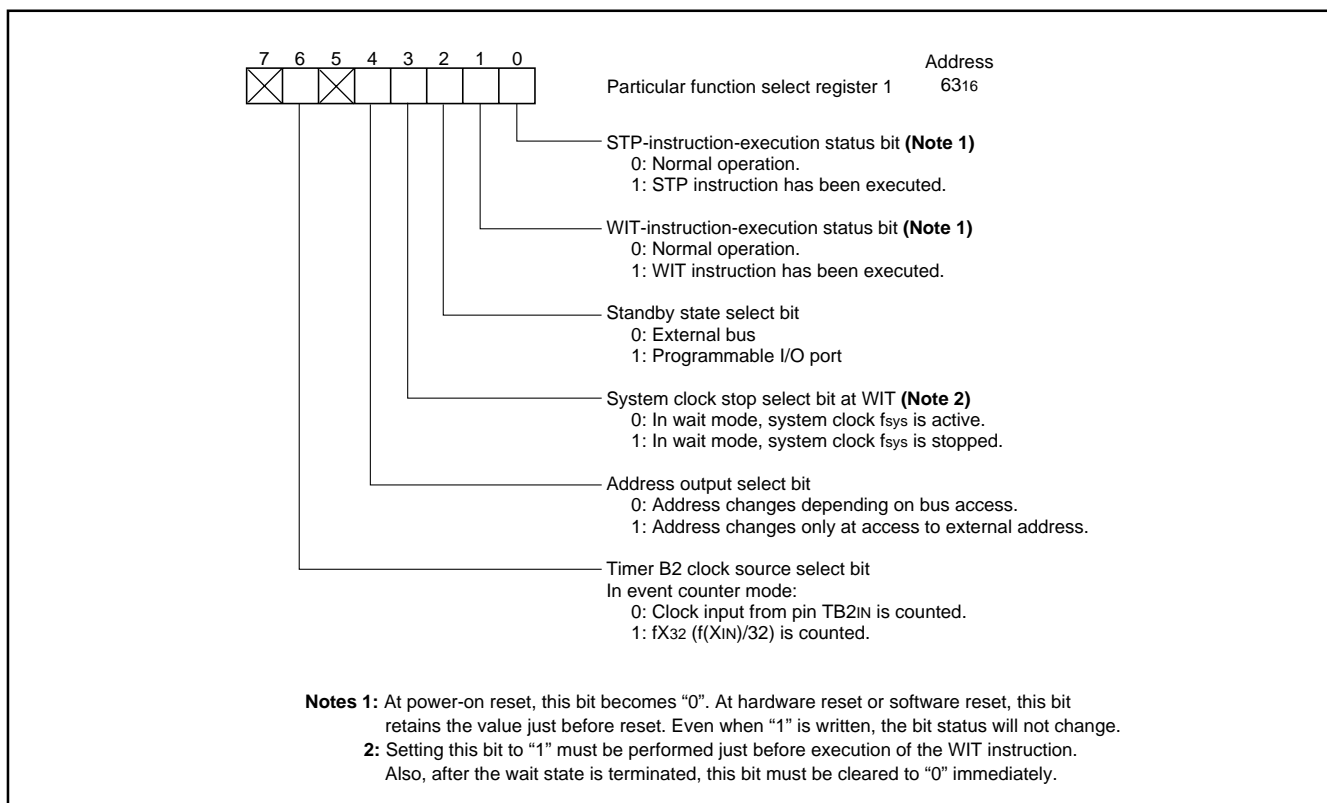

Fig. 101 Bit configuration of particular function select register 1

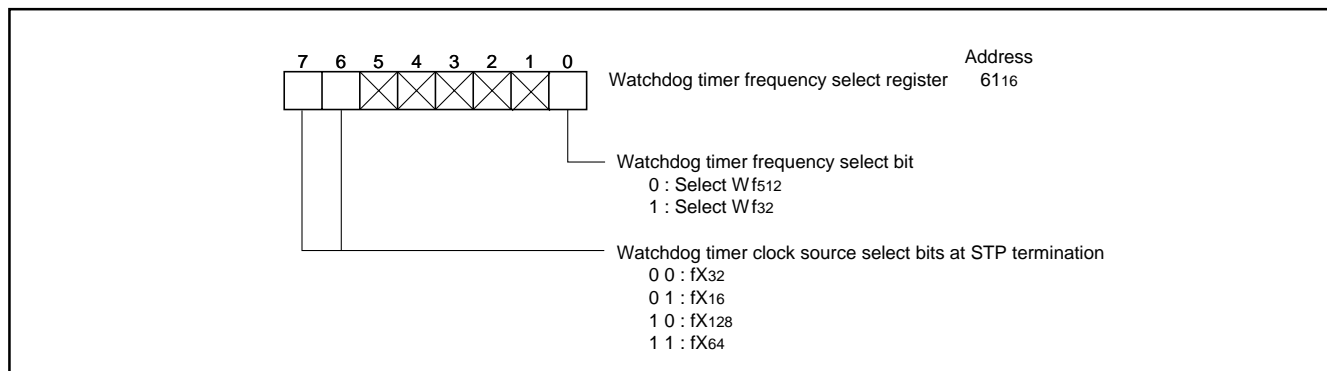

Fig. 102 Bit configuration of watchdog timer frequency select register



MITSUBISHI MICROCOMPUTERS

# M37902FCCHP, M37902FGCHP, M37902FJCHP

SINGLE-CHIP 16-BIT CMOS MICROCOMPUTER

---

## WIT mode

When the WIT instruction is executed with the system clock stop select bit at WIT (bit 3 of the particular function select register 1 in Figure 101) being "0",  $\phi_{BIU}$ ,  $\phi_{CPU}$ , and divide clocks  $Wf_{32}$  and  $Wf_{512}$  are stopped in the "L" state. However, the oscillation circuit, PLL circuit, input clock  $f_{XIN}$ , system clock  $f_{sys}$ ,  $\phi_1$ , and peripheral devices' clock  $f_1$  to  $f_{4096}$  remain operating. Therefore, BIU and CPU are stopped, whereas timers A and B, serial I/O, and the A-D converter, which use the peripheral devices' clocks  $f_1$  to  $f_{4096}$ , are still operating. Note that the watchdog timer is stopped.

On the other hand, when the WIT instruction is executed with the system clock stop select bit at WIT being "1", the oscillation circuit, PLL circuit, and input clock  $f_{XIN}$  are operating, while system clock  $f_{sys}$ ,  $\phi_{BIU}$ ,  $\phi_{CPU}$ , and peripheral devices' clocks stop operating. As a result, the A-D converter and watchdog timer, which use peripheral devices' clocks  $f_1$  to  $f_{4096}$ ,  $Wf_{32}$  and  $Wf_{512}$ , are stopped. At this time, timers A and B operate only in the event counter mode, and serial I/O communication is active only while an external clock is selected. If the internal peripheral devices are not used in the WIT mode, the latter is better because the current dissipation is more saved. Note that the system clock stop select bit at WIT is to be set to "1" immediately before execution of the WIT instruction and cleared to "0" immediately after the WIT mode is terminated.

The WIT state is terminated by acceptance of an interrupt request, and then, supply of  $\phi_{BIU}$  and  $\phi_{CPU}$  will restart. Since the oscillation circuit, PLL circuit, and clock input  $f_{XIN}$  are operating in the WIT mode, an interrupt processing can be executed just after the WIT mode termination.

MITSUBISHI MICROCOMPUTERS

# M37902FCCHP, M37902FGCHP, M37902FJCHP

SINGLE-CHIP 16-BIT CMOS MICROCOMPUTER

---

## POWER SAVING FUNCTION

The following functions can save the power dissipation of the whole system.

### (1) External bus fixation in standby state

By setting the standby state select bit (bit 2 of the particular function select register 1) to "1", in the stop or wait mode, the I/O pins of the external buses and bus control signals can be switched to programmable I/O port pins. By setting these pins' state with the corresponding port registers and port direction registers, unnecessary current will not flow between the microcomputer and external devices. As a result, in the stop or wait mode, the power dissipation of the whole system can be lowered. Table 18 lists the correspondence between the external buses, bus control signals, and programmable I/O port pins.

This function is valid only in the stop or wait mode. At termination of the stop or wait mode, the original function of external buses and bus control signals become valid.

Table 18. Correspondence between external buses, bus control signals, and programmable I/O port pins

External buses, Bus control signals	Standby state select bit	
	0	1
A0 to A7, A8 to A15, A16 to A23	A0 to A7, A8 to A15, A16 to A23	P100 to P107, P110 to P117, P00 to P07
D0 to D7, D8 to D15	D0 to D7, D8 to D15 <b>(Note)</b>	P10 to P17, P20 to P27
$\overline{RD}$ , $\overline{BLW}$ , $\overline{BHW}$	$\overline{RD}$ , $\overline{BLW}$ , $\overline{BHW}$ <b>(Note)</b>	P31, P32, P33
$\overline{CS0}$	$\overline{CS0}$	P90

**Note:** When the external data bus width = 8 bits (BYTE = VCC level), this becomes a programmable I/O port pin, regardless of the standby state select bit's contents.

### (2) Stop of system clock in wait mode

In the wait mode, if the internal peripheral devices need not to operate, the system clock stop select bit at WIT (bit 3 of the particular function select register 1) = "1", both of system clock  $f_{sys}$  and peripheral devices' clock stop their operations, and the power dissipation can be saved.

For details, refer to the section on the standby function.

### (3) Stop of oscillation circuit

When an externally-generated-stable clock is input to pin XIN, the power dissipation can be saved if both of the following conditions are met:

- the external clock input select bit (bit 1 of the particular function select register 0) = "1".
- the oscillation driver between pins XIN and XOUT stops its operation.

At this time, the output level at pin XOUT is fixed to "H". When not using a PLL output clock, also, the supply of  $\phi_{BIU}$  and  $\phi_{CPU}$  restarts their operations just after the microcomputers returns from the stop

mode, owing to an interrupt request occurrence. Therefore, an instruction can be executed just after the termination of the stop mode. For details, refer to the section on the clock generating circuit and standby function.

### (4) Disconnection from pin VREF

When not using the A-D converter and D-A converter, by setting the VREF connection select bit (bit 6 of the A-D control register 1) to "1", the resistor ladder network of the A-D converter will be disconnected from the reference voltage input pin (VREF). In this case, no current flows from pin VREF to the resistor ladder network, and the power dissipation can be saved. Note that, after the VREF connection select bit changes from "1" (VREF disconnected) to "0" (VREF connected), be sure that a waiting time of 1  $\mu$ s of more has passed before the A-D conversion starts. For details, refer to the sections on the A-D converter and D-A converter.

### (5) Address output selection

In the memory expansion mode or microprocessor mode, when the address output select bit (bit 4 of the particular function select register 1) becomes "1", the unnecessary change of address pins' state will be avoided, without output of an address at access to the internal area.

For details, refer to the section on the BIU.

MITSUBISHI MICROCOMPUTERS

# M37902FCCHP, M37902FGCHP, M37902FJCHP

SINGLE-CHIP 16-BIT CMOS MICROCOMPUTER

## DEBUG FUNCTION

When the CPU fetches an instruction code, an interrupt request will be generated if a selected condition is satisfied, as a result of comparison between a specified address and the start address where the instruction code is stored (the contents of PG and PC). The decision whether this condition is satisfied or not is called address matching detection, and the interrupt generated by this detection is called an address matching detection interrupt. (For interrupt vector addresses, refer to the section on interrupts.)

In the address matching detection, a non-maskable interrupt routine is proceeded without execution of the original instruction which has been allocated to the target address.

The debug function provides the following two modes:

- the address matching detection mode, which is used to avoid the area where program exists or modify a program.
- the out-of-address-area detection mode, which is used to detect a program runaway.

Figures 103 shows the block diagram of the debug function. Figures 104 and 105 show the bit configurations of the debug control registers 0, 1, and address compare registers 0, 1, respectively.

The detect condition select bits of the debug control register 0 can select one condition between the following 4 conditions. When the selected address condition is satisfied, an address matching detection interrupt request will be generated:

(1) Address matching detection 0

The contents of PG and PC match with the address which has been set in the address compare register 0.

(2) Address matching detection 1

The contents of PG and PC match with the address which has been set in the address compare register 1.

(3) Address matching detection 2

The contents of PG and PC match with the address which has been set in either of the address compare register 0 or address compare register 1.

(4) Out-of-address-area detection

The contents of PG and PC are less than the address which has

been set in the address compare register 0 or larger than the address which has been set in the address compare register 1.

By setting the detect enable bit of the debug control register 0 to "1", an address matching detection interrupt request will be generated if any one of the above address conditions is satisfied. Clearing the detect enable bit to "0" generates no interrupt request even if any of the above address conditions is satisfied.

The address compare register access enable bit of the debug control register 1 must be set to "1" by the instruction just before the access operation (read/write). Then, this bit must be cleared to "0" (disabled) by the next instruction. While this bit = "0", the address compare registers 0, 1 cannot be accessed.

The address-matching-detection 2 decision bit of the debug control register 1 decides, whether the address which has been set in the address compare register 0 or 1 matches with the contents of PG, PC, when the address matching detection 2 is selected. The contents of this bit is invalid when address matching detection 0 or 1 is selected.

In order to use the debug function to avoid the area where program exists or modify a program, perform the necessary processing within an address matching interrupt routine. As a result, the contents of PG, PC, PS at acceptance of an address matching detection interrupt request (i.e. the address at which an address matching detection condition is satisfied) have been pushed on to the stack. If a return destination address after the interrupt processing is to be altered, rewrite the contents of the stack, and then return by the RTI instruction.

To use the debug function to detect a program runaway, set an address area where no program exists into the address compare registers 0 and 1 by using the out-of-address-area detection. When the CPU fetches instruction codes from this address area and executes them, an address matching detection interrupt request will be generated.

The above debug function cannot be evaluated by a debugger, so that the debug function must not be used while a debugger is running.

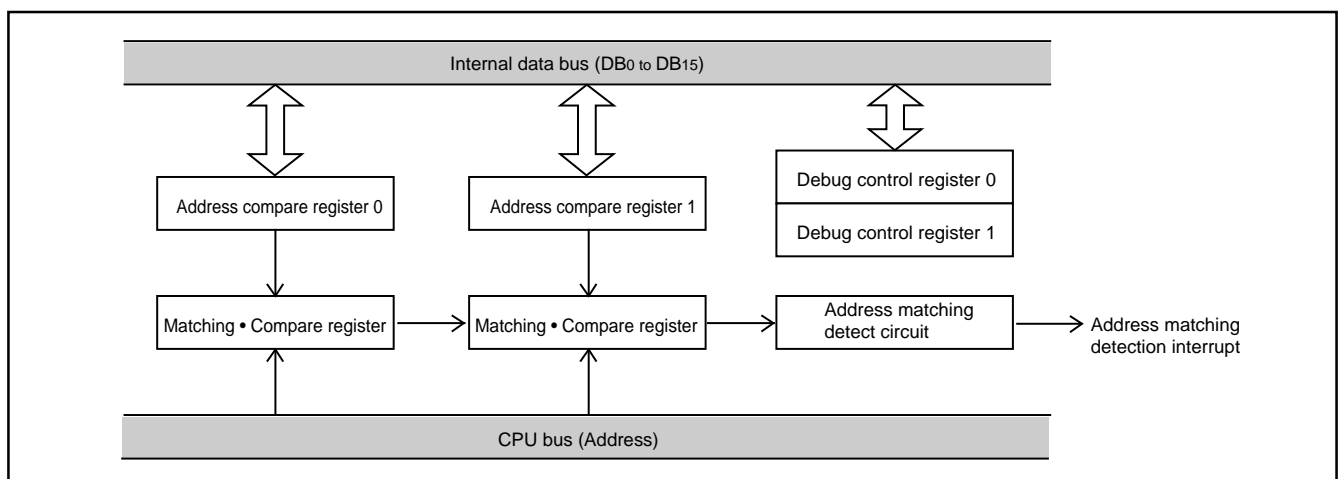

Fig 103. Block diagram of debug function

MITSUBISHI MICROCOMPUTERS

# M37902FCCHP, M37902FGCHP, M37902FJCHP

SINGLE-CHIP 16-BIT CMOS MICROCOMPUTER

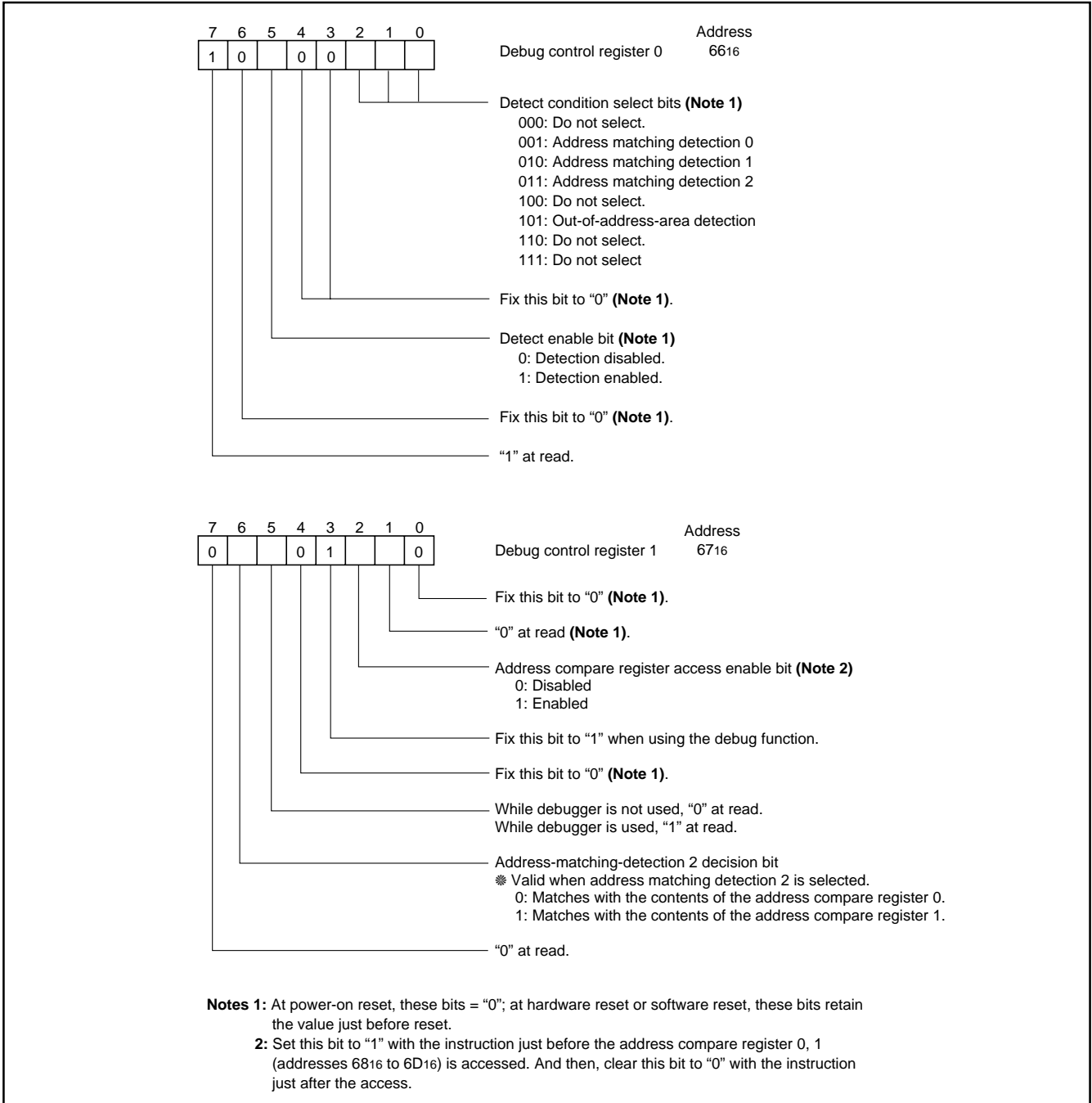

Fig. 104 Bit configuration of debug control register 0, 1

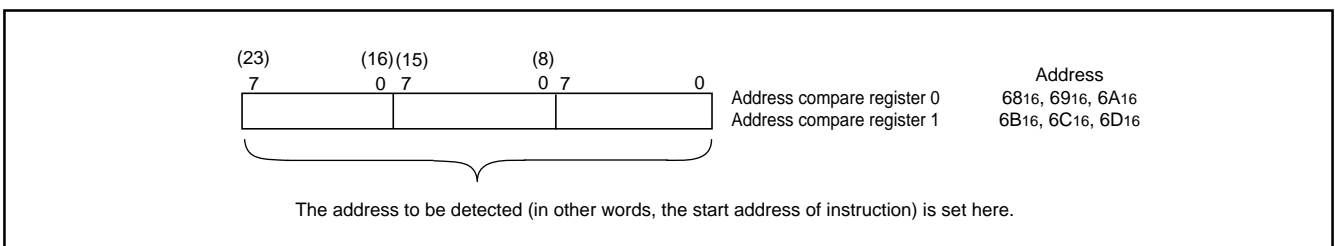

Fig. 105 Bit configuration of address compare register 0, 1



MITSUBISHI MICROCOMPUTERS

# M37902FCCHP, M37902FGCHP, M37902FJCHP

SINGLE-CHIP 16-BIT CMOS MICROCOMPUTER

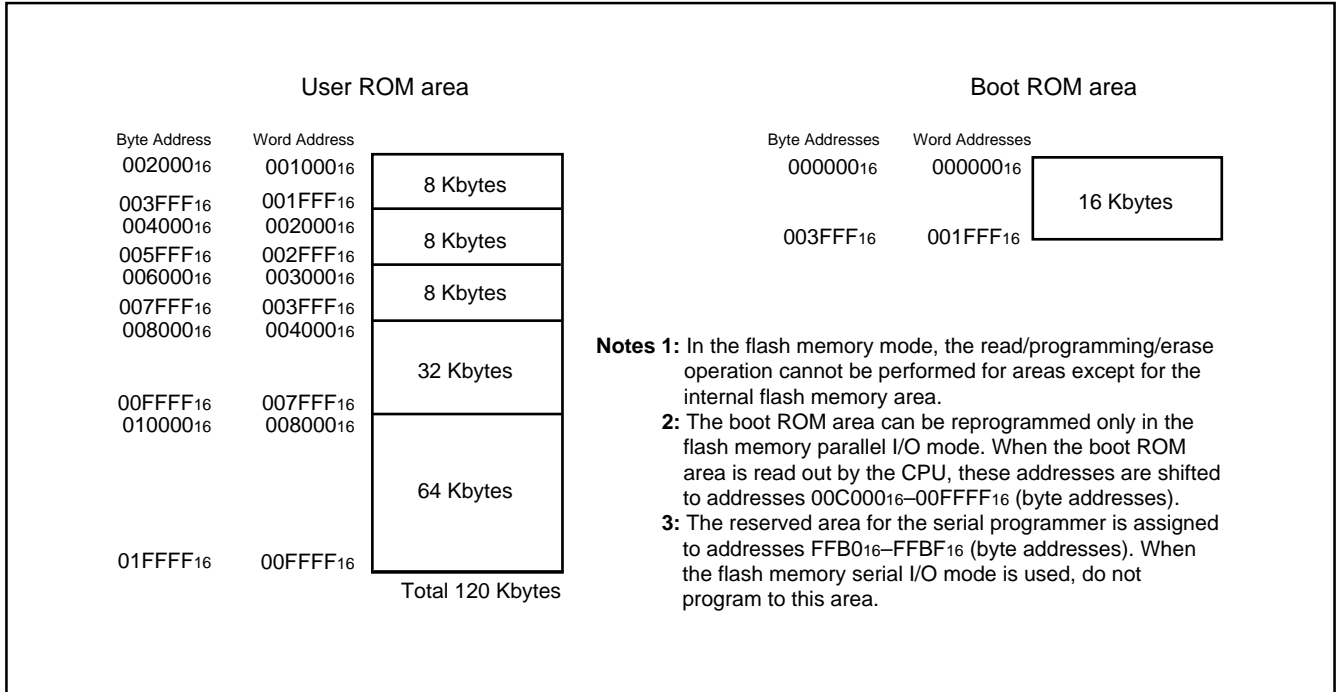

Fig 107. M37902FCCHP: block configuration of internal flash memory

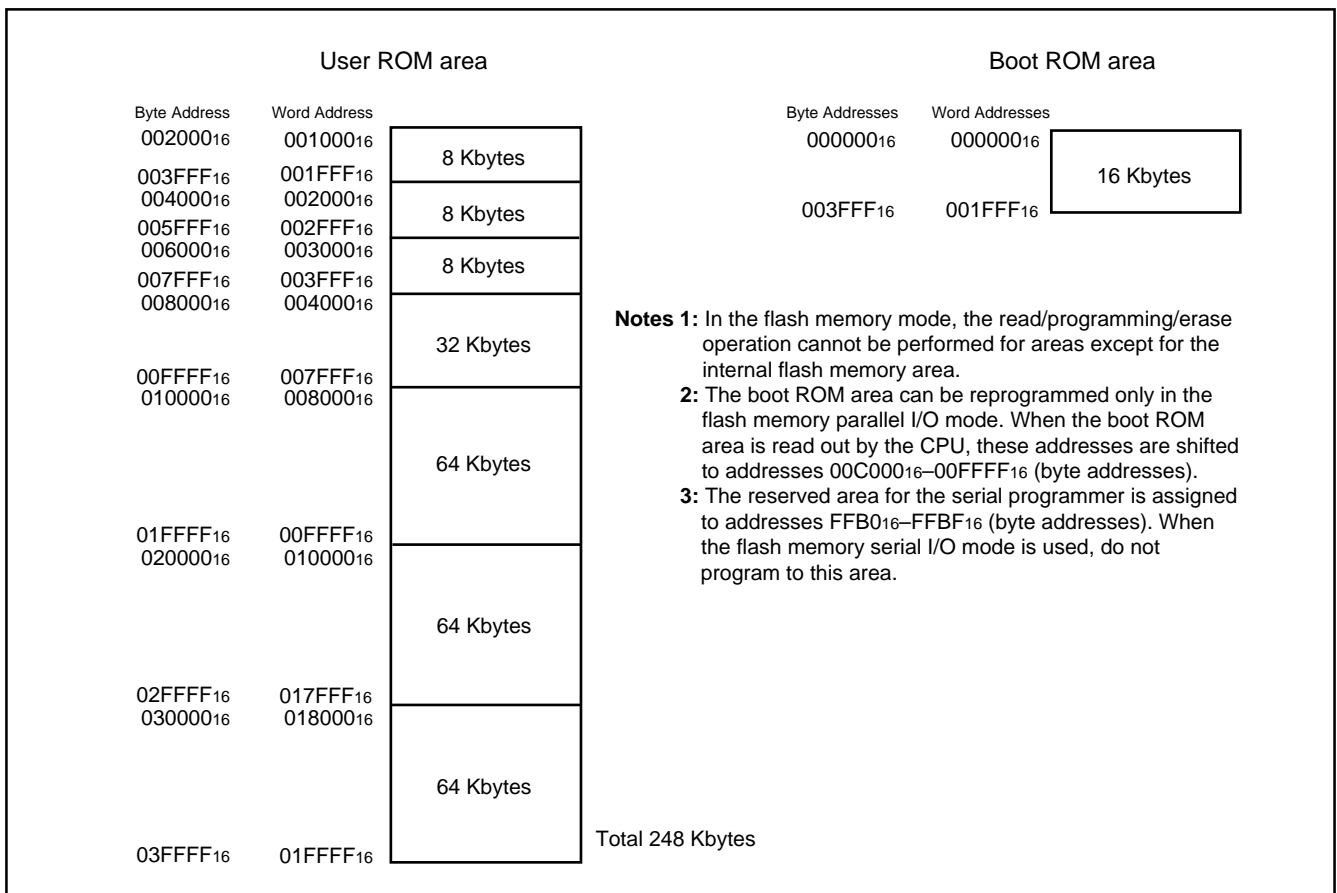

Fig 108. M37902FGCHP: block configuration of internal flash memory

MITSUBISHI MICROCOMPUTERS

# M37902FCCHP, M37902FGCHP, M37902FJCHP

SINGLE-CHIP 16-BIT CMOS MICROCOMPUTER

---

## Flash Memory Parallel I/O Mode

The flash memory parallel I/O mode is used to manipulate the internal flash memory with a parallel programmer. This parallel programmer uses the software commands listed in Table 19 to do the flash memory manipulations, such as read/programming/erase operations.

In the flash memory parallel I/O mode, each block can be protected from erasing/programming (in other words, block lock).

Table 19. Software commands (flash memory parallel I/O mode)

Software Command
Read Array
Read Status Register
Clear Status Register
Page Programming ( <b>Note</b> )
Block Erase
Erase All Unlocked Block
Lock Bit Programming
Read Lock Bit Status

**Note:** Programming is performed in a unit of 256 bytes, with the low-order address assigned in the range of 00<sub>16</sub>—FF<sub>16</sub> (byte addresses).

## User ROM Area and Boot ROM Area

The user ROM area and boot ROM area can be reprogrammed in the flash memory parallel I/O mode.

The programming and block erase operations can be performed only to these areas.

The boot ROM area, 16 Kbytes in size, is assigned to addresses 0000<sub>16</sub>—3FFF<sub>16</sub> (byte addresses), so that programming and block erase operations can be performed only to this area. (Access to any address out of this area is prohibited).

The erasable block in the boot ROM area is only one block, consisting of 16 Kbytes. The reprogramming control firmware to be used in the flash memory serial I/O mode has been stored to this boot ROM area on our shipment. Therefore, do not reprogram the boot ROM area if the user uses the flash memory serial I/O mode.

Addresses FFB0<sub>16</sub> to FFBF<sub>16</sub> are the reserved area for the serial programmer. Therefore, when the user uses the flash memory serial I/O mode, do not program to this area.

Note that, when the boot ROM area is read out from the CPU in the CPU reprogramming mode, described later, its addresses will be shifted to C000<sub>16</sub>—FFFF<sub>16</sub> (byte addresses).

MITSUBISHI MICROCOMPUTERS

# M37902FCCHP, M37902FGCHP, M37902FJCHP

SINGLE-CHIP 16-BIT CMOS MICROCOMPUTER

---

## Flash Memory Serial I/O Mode

In the flash memory serial I/O mode, addresses, data, and software commands, which are required to read/program/erase the internal flash memory, are serially input and output with a fewer pins and the dedicated serial programmer.

In this mode, being different from the flash memory parallel I/O mode, the CPU controls reprogramming of the flash memory (using the CPU reprogramming mode), serial input of the reprogramming data, etc.

The reprogramming control firmware for the flash memory serial I/O mode has been stored in the boot ROM area on shipment of the product from us. Note that, then, the flash memory serial I/O mode will become unavailable if the boot ROM area has been reprogrammed in the flash memory parallel I/O mode.

Note that, also, this reprogramming control firmware for the flash memory serial I/O mode is subject to change.

Figure 112 shows the pin connection in the flash memory serial I/O mode.

The three pins, SCLK, SDA, and BUSY, are used to input and output serial data.

The SCLK pin is the input pin of external transfer clocks. The SDA pin is the I/O pin of transmit and receive data, and its output acts as the N-channel open-drain output. To the SDA pin, connect an external pullup resistor (about 1 k $\Omega$ ). The BUSY pin is the output pin of the BUSY flag (CMOS output) and goes "H" during BUSY periods owing to a certain operation, such as transmit, receive, erase, programming, etc.

Transmit and receive data are serially transferred 8 bits at a time.

In the flash memory serial I/O mode, only the user ROM area can be reprogrammed; the boot ROM area is not accessible.

Addresses FF0<sub>16</sub> to FFBF<sub>16</sub> are the reserved area for the serial programmer. Therefore, when the user uses the flash memory serial I/O mode, do not program to this area.



# MITSUBISHI MICROCOMPUTERS

## M37902FCCHP, M37902FGCHP, M37902FJCHP

SINGLE-CHIP 16-BIT CMOS MICROCOMPUTER

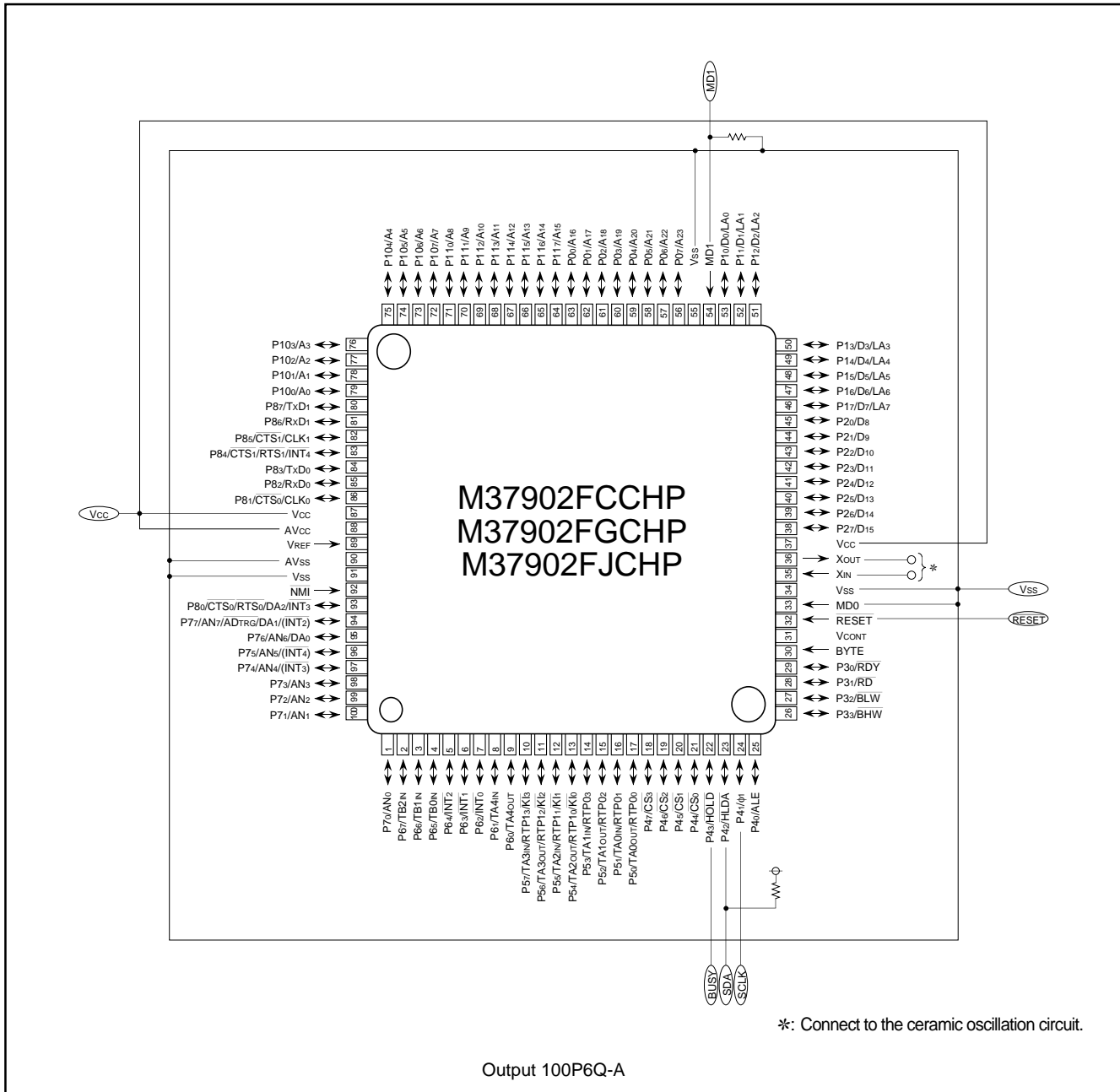

Fig.112 Pin connection of M37902FxCHP in flash memory serial I/O mode

MITSUBISHI MICROCOMPUTERS

# M37902FCCHP, M37902FGCHP, M37902FJCHP

SINGLE-CHIP 16-BIT CMOS MICROCOMPUTER

## CPU Reprogramming Mode

The CPU reprogramming mode is used to perform the operations for the internal flash memory (reading, programming, erasing) under control of the CPU.

In this mode, only the user ROM area can be reprogrammed; the boot ROM area cannot be reprogrammed.

The user-original reprogramming control software for the CPU reprogramming mode can be stored in either the user ROM area or the boot ROM area. Because the CPU cannot read out the flash memory in the CPU reprogramming mode, the above software must be transferred to the internal RAM in advance to be executed.

## Boot Mode

The user-original reprogramming control software for the CPU reprogramming mode must be stored into the user ROM area or the boot ROM area in the flash memory parallel I/O mode in advance. (If this program has been stored into the boot ROM area, the flash memory serial I/O mode will become unavailable).

Note that addresses of the boot ROM area depend on the accessing ways to the boot ROM area. When accessing in the flash memory

parallel I/O mode, these addresses will be shifted to 0000<sub>16</sub> to 3FFF<sub>16</sub> (byte address). On the other hand, when accessing with the CPU, these addresses will be shifted to C000<sub>16</sub> to FFFF<sub>16</sub> (byte address).

Reset removal with both of the MD0 and MD1 pins held "L" invokes the normal microcomputer mode, and the CPU operates using the control software stored in the user ROM area. In this case, the boot ROM area is not accessible.

Removing reset with the MD0 pin held "L" and the MD1 pin "H", the CPU starts its operation using the reprogramming control software stored in the boot ROM area. This mode is called the boot mode. The reprogramming control software in the boot ROM area can also reprogram the user ROM area.

After reset removal, be sure not to change the status at pins MD0 and MD1.

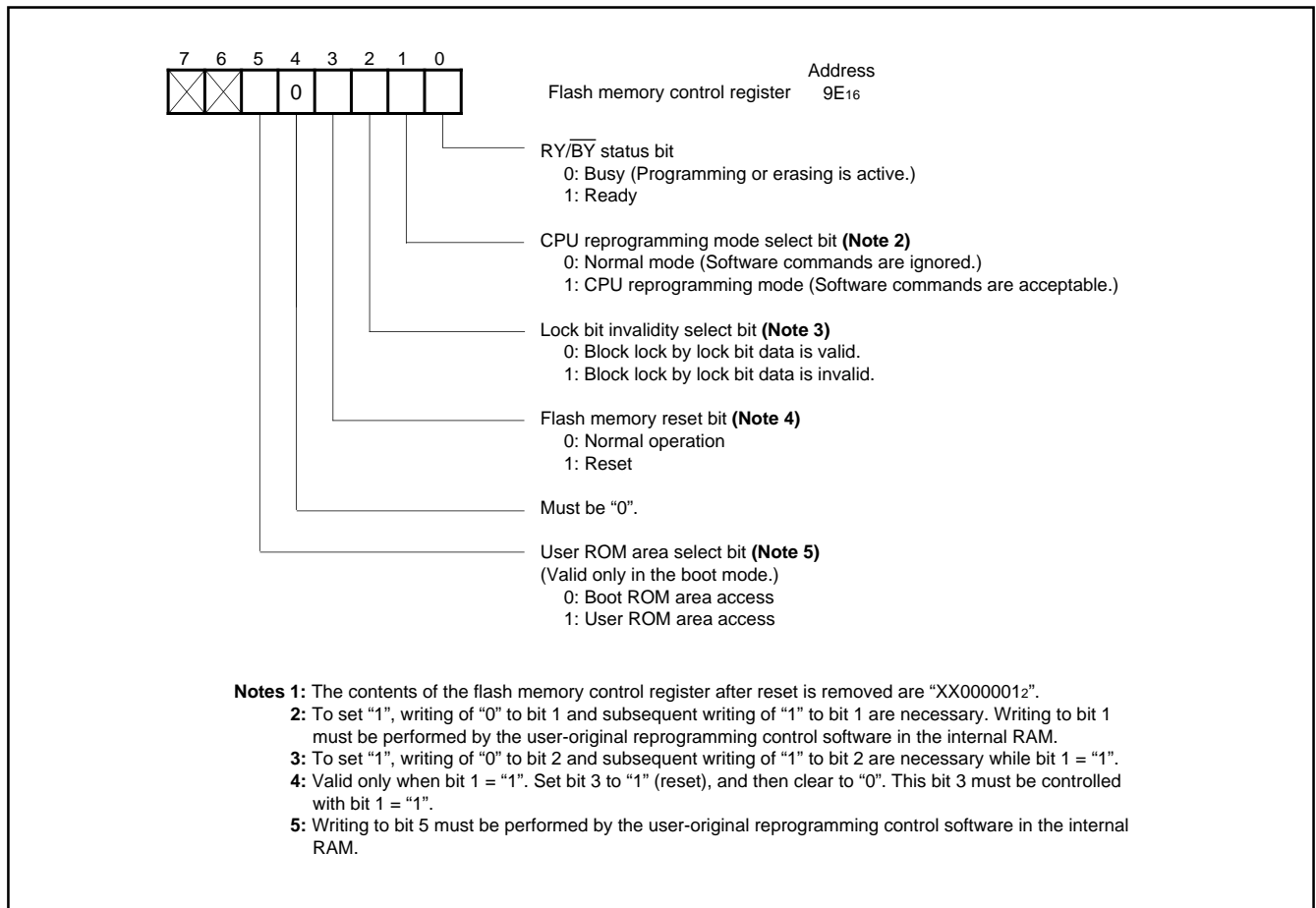

Fig. 114 Bit configuration of flash memory control register

MITSUBISHI MICROCOMPUTERS

# M37902FCCHP, M37902FGCHP, M37902FJCHP

SINGLE-CHIP 16-BIT CMOS MICROCOMPUTER

---

## Function overview (CPU reprogramming mode)

The CPU reprogramming mode is available in the single-chip mode, memory expansion mode, and boot mode to reprogram the user ROM area only.

In the CPU reprogramming mode, the CPU erases, programs, and reads the internal flash memory by writing software commands. Note that the user-original reprogramming control software must be transferred to the internal RAM in advance to be executed.

The CPU reprogramming mode becomes active when "1" is written into the flash memory control register's bit 1 (the CPU reprogramming mode select bit) shown in Figure 114, and software commands become acceptable.

In the CPU reprogramming mode, software commands and data are all written to and read from even addresses (Note that address A<sub>0</sub> in byte addresses = "0".) 16 bits at a time. Therefore, a software command consisting of 8 bits must be written to an even address; therefore, any command written to an odd address will be invalid. Since the write data at the 2nd cycle of a programming command consists of 16 bits, this data must be written to even and odd addresses.

The write state machine (WSM) in the flash memory controls the erase and programming operations. What the status of the WSM operation is and whether the programming or erase operation has been completed normally or terminated by an error can be examined by reading the status register.

Figure 114 shows the bit configuration of the flash memory control register.

Bit 0 (the RY/ $\overline{BY}$  status bit) is a read-only bit for indicating the WSM operation. This bit goes to "0" (BUSY) while the automatic programming/erase operation is active and goes to "1" (READY) during the other operations.

Bit 1 serves as the CPU reprogramming mode select bit. Writing of "1" to this bit selects the CPU reprogramming mode, and software commands will be acceptable. Because the CPU cannot directly access the internal flash memory in the CPU reprogramming mode, writing to this bit 1 must be performed by the user-original reprogramming control software which has been transferred to the internal RAM in advance. To set bit 1 to "1", it is necessary to write "0" and "1" to this bit 1 successively. On the other hand, to clear this bit to "0", it is sufficient only to write "0".

Bit 2 serves as the lock bit invalidity select bit, and setting this bit to "1" invalidates the protection by a lock bit against erasing and programming (block lock). The lock bit invalidity select bit can invalidate the lock bit function but set no lock bit itself. However, if erasing is performed with this bit = "1", a lock bit with value "0" (the locked state) will be set to "1" (the unlocked state) after the erasing has been completed. To set the lock bit invalidity select bit to "1", write "0" and "1" to this bit 2 successively with the CPU reprogramming mode select bit = "1". The manipulation of bit 2 is allowed only when the CPU reprogramming mode select bit = "1".

Bit 3 (the flash memory reset bit) resets the control circuit of the internal flash memory and is used when the CPU reprogramming mode is terminated or when an abnormal access to the flash memory happens. Writing of "1" to bit 3 with the CPU reprogramming mode select bit = "1" performs the reset operation. To remove the reset, write "0" to bit 3 subsequently.

Bit 5 serves as the user ROM area select bit and is valid only in the boot mode. Setting this bit to "1" in the boot mode switches an acces-

sible area from the boot ROM area to the user ROM area. To use the CPU reprogramming mode in the boot mode, set this bit to "1". Note that when the microcomputer is booted up in the user ROM area, only the user ROM area is accessible and bit 5 is invalid; on the other hand, when the microcomputer is in the boot mode, bit 5 is valid independent of the CPU reprogramming mode. To rewrite bit 5, execute the user-original reprogramming control software transferred to the internal RAM in advance.

Figure 115 shows the CPU reprogramming mode set/termination flowchart, and be sure to follow this flowchart. As shown in Note 1 of Figure 115, before selecting the CPU reprogramming mode, set the processor mode register 1's bit 7 (the internal ROM bus cycle select bit) to "0" and set flag I to "1" to avoid an interrupt request input.

When an  $\overline{NMI}$  interrupt or a watchdog timer interrupt request is generated in the CPU reprogramming mode, when an input to the  $\overline{RESET}$  pin is "L", or when the software reset is performed, the flash memory control circuit and flash memory control register will be reset.

When the flash memory is reset during the erase or programming operation, this operation is cancelled and the target block's data will be invalid. Just before writing a software command related to the erase/programming operation, be sure to write to the watchdog timer. Also, be sure to set the  $\overline{NMI}$  pin to "H" to avoid an  $\overline{NMI}$  interrupt request occurrence. In the CPU reprogramming mode, be sure not to use the **STP** and **WIT** instructions.

MITSUBISHI MICROCOMPUTERS

# M37902FCCHP, M37902FGCHP, M37902FJCHP

SINGLE-CHIP 16-BIT CMOS MICROCOMPUTER

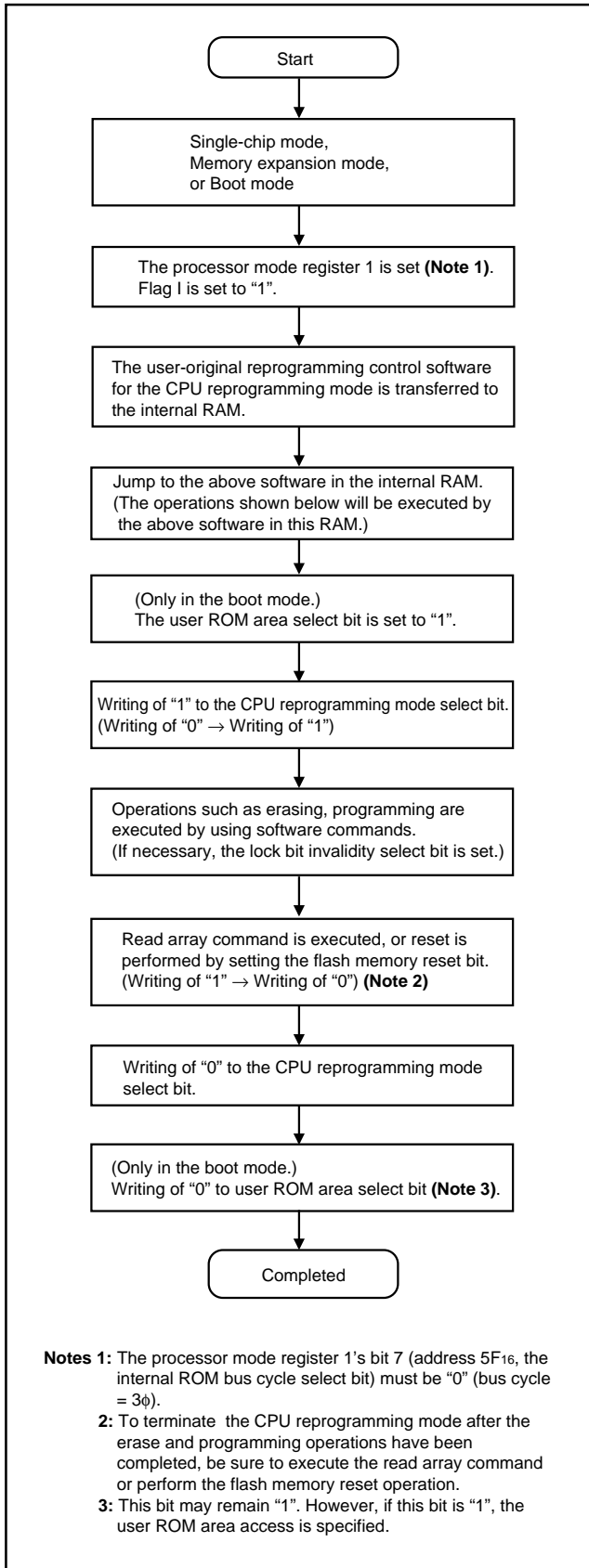

Fig. 115 CPU reprogramming mode set/termination flowchart

## Software Commands

Table 20 lists the software commands.

By writing a software command after the CPU reprogramming select bit has been set to "1", erasing, programming, etc. can be specified. Note that, at software commands' input, the high-order byte (D<sub>8</sub>–D<sub>15</sub>) is ignored. (Except for the write data at the 2nd cycle of a page programming command.)

Software commands are explained as below.

### Read Array Command (FF<sub>16</sub>)

By writing command code "FF<sub>16</sub>" at the 1st bus cycle, the microcomputer enters the read array mode. If an address to be read is input in the next or the following bus cycles, the contents at the specified address are output to the data bus (D<sub>0</sub> to D<sub>15</sub>) in a unit of 16 bits.

The read array mode is maintained until writing of another software command.

### Read Status Register Command (70<sub>16</sub>)

Writing command code "70<sub>16</sub>" at the 1st bus cycle outputs the contents of the status register to the data bus (D<sub>0</sub>–D<sub>7</sub>) by a read at the 2nd bus cycle.

The status register is explained later.

### Clear Status Register Command (50<sub>16</sub>)

This command clears three status bits (SR.3–5) each of which is set to "1" to indicate that the operation has been terminated by an error. To clear these bits, write command code "50<sub>16</sub>" at the 1st bus cycle.

### Page Programming Command (41<sub>16</sub>)

Page programming facilitates quick programming of 128 words (a page = 256 bytes) at a time. To initiate page programming, write command code "41<sub>16</sub>" at the 1st bus cycle; then, program a series of data, in a unit of 16 bits, sequentially from the 2nd to the 129th bus cycle. It is necessary, at this time, to increment address A<sub>0</sub>–A<sub>7</sub> from "00<sub>16</sub>" to "FE<sub>16</sub>" by +2. (Programmed to even addresses.)

Upon completion of data loading, automatic programming (data programming and verification) operation is started.

The completion of the automatic programming operation is recognized by a read of the status register or a read of the flash memory control register. As the automatic programming operation starts, the microcomputer enters the read status register mode automatically to allow reading out the contents of the status register. Bit 7 of the status register (SR.7) is cleared to "0" simultaneously with the start of the automatic programming operation; and also, bit 7 returns to "1" by the end of it. Until writing of the read array command (FF<sub>16</sub>), writing of the read lock bit status command (71<sub>16</sub>), or performing the reset operation with the flash memory reset bit, this read status register mode is maintained. In continuous programming, if there is no programming error, page programming commands can be executed with the read status register mode kept.

MITSUBISHI MICROCOMPUTERS

# M37902FCCHP, M37902FGCHP, M37902FJCHP

SINGLE-CHIP 16-BIT CMOS MICROCOMPUTER

Table 20. Software commands (CPU reprogramming mode)

Command	1st cycle			2nd cycle			3rd cycle		
	Mode	Address	Data (D0 to D7)	Mode	Address	Data	Mode	Address	Data
Read Array	Write	X (Note 2)	FF16	—	—	—	—	—	—
Read Status Register	Write	X	7016	Read	X	SRD (Note 3)	—	—	—
Clear Status Register	Write	X	5016	—	—	—	—	—	—
Page Programming (Note 3)	Write	X	4116	Write	WA0 (Note 4)	WD0 (Note 4)	Write	WA1	WD1
Block Erase	Write	X	2016	Write	BA (Note 5)	D016	—	—	—
Erase All Unlocked Block	Write	X	A716	Write	X	D016	—	—	—
Lock Bit Programming	Write	X	7716	Write	BA	D016	—	—	—
Read Lock Bit Status	Write	X	7116	Read	BA	D6 (Note 6)	—	—	—

**Notes 1:** At software commands' input, the high-order byte of data (D8–D15) is ignored.

**2:** X = An arbitrary address in the user ROM area. (Note that A0 = "0".)

**3:** SRD = Status register data.

**4:** WA = Write address, WD = Write data (16 bits).

WA and WD must be set from "0016" to "FE16". (Byte addresses. Incremented by +2. Address A0 = "0".) Page size = 128 words (128 X 16 bits).

**5:** Block address: the maximum address of each block must be input. Note that address A0 = "0".

**6:** D6 indicates the block lock status.

"1" = unlocked. "0" = locked.

The RY/ $\overline{\text{BY}}$  status bit of the flash memory control register goes "0" during the automatic programming operation; and also, it goes "1" after the end of it, the same way as bit 7 of the status register.

Before execution of the next command, be sure to verify that bit 7 of the status register (SR.7) or the RY/ $\overline{\text{BY}}$  status bit is set to "1" (READY). During the automatic programming operation, writing of commands and access to the flash memory must not be performed. Reading out the status register after the automatic programming operation is completed reports the result of it. For details, refer to the section on the status register.

Figure 116 shows an example of the page programming flowchart. Note that each block can be protected from programming by using a lock bit. For details, refer to the section on the data protect function. Additional programming to any page that has already been programmed is prohibited.

## Block Erase Command (2016/D016)

Writing command code "2016" at the 1st bus cycle and writing verify command code "D016" and the maximum address of the block (Note that address A0 = "0".) at the subsequent 2nd bus cycle initiate the automatic erase (erasing and erase verification) operation for the specified block.

The completion of the automatic erase operation is verified by a read of the status register or a read of the flash memory control register. As the automatic erase operation starts, the microcomputer enters the read status register mode automatically to allow reading out the contents of the status register. Bit 7 of the status register (SR.7) is cleared to "0" simultaneously with the start of the automatic erase operation; and also, it returns to "1" by the end of it. The read status register mode is maintained until writing of the read array command (FF16), writing of the read lock bit status command (7116), or performing the reset operation with the flash memory reset bit.

The RY/ $\overline{\text{BY}}$  status bit of the flash memory control register goes "0" during the automatic erase operation; and also, it goes "1" after the end of it, the same way as bit 7 of the status register.

Before execution of the next command, be sure to verify that bit 7 of

the status register (SR.7) or the RY/ $\overline{\text{BY}}$  status bit is set to "1" (READY). During the automatic erase operation, writing of commands and access to the flash memory must not be performed.

Reading out the status register after the automatic erase operation is completed reports the result of it. For details, refer to the section on the status register.

Figure 117 shows an example of the block erase flowchart.

Note that each block can be protected from erasing by using a lock bit. For details, refer to the section on the data protect function.

MITSUBISHI MICROCOMPUTERS  
**M37902FCCHP, M37902FGCHP, M37902FJCHP**

SINGLE-CHIP 16-BIT CMOS MICROCOMPUTER

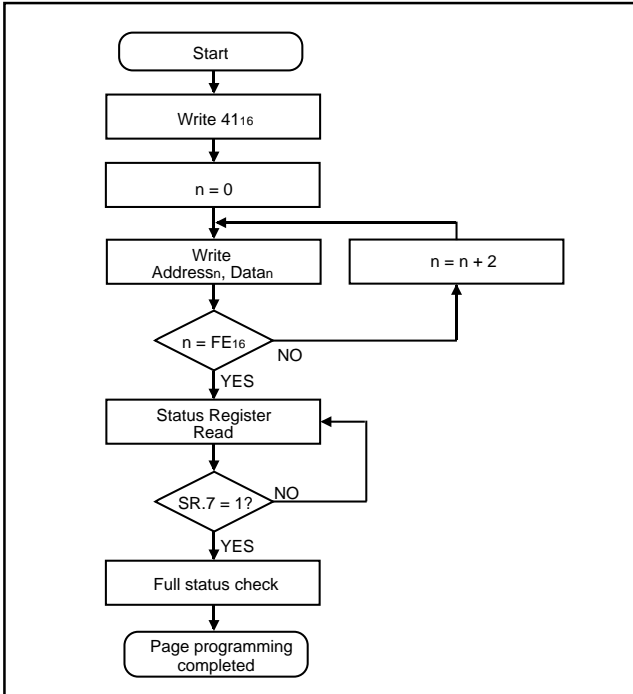

Fig. 116 Page programming flowchart

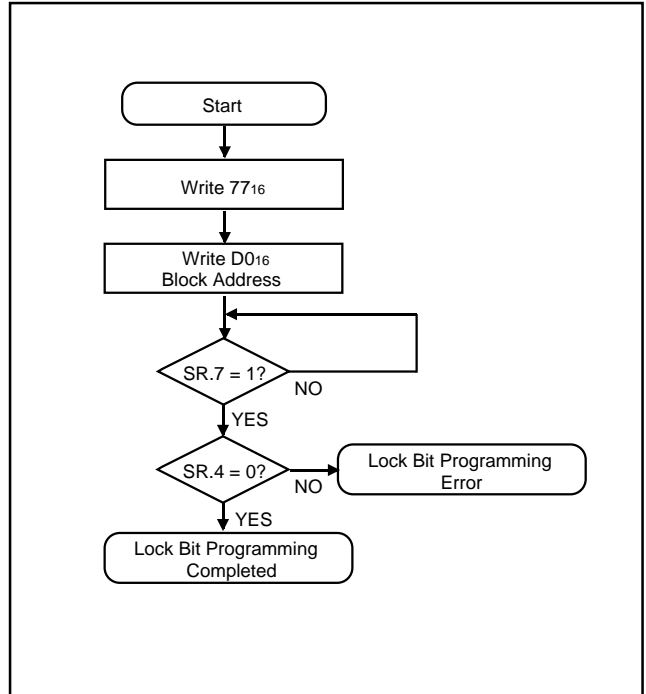

Fig. 118 Lock bit programming flowchart

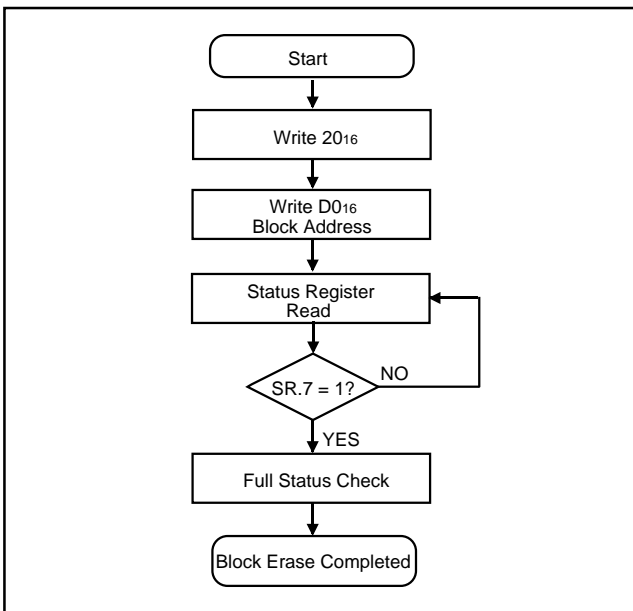

Fig. 117 Block erase flowchart

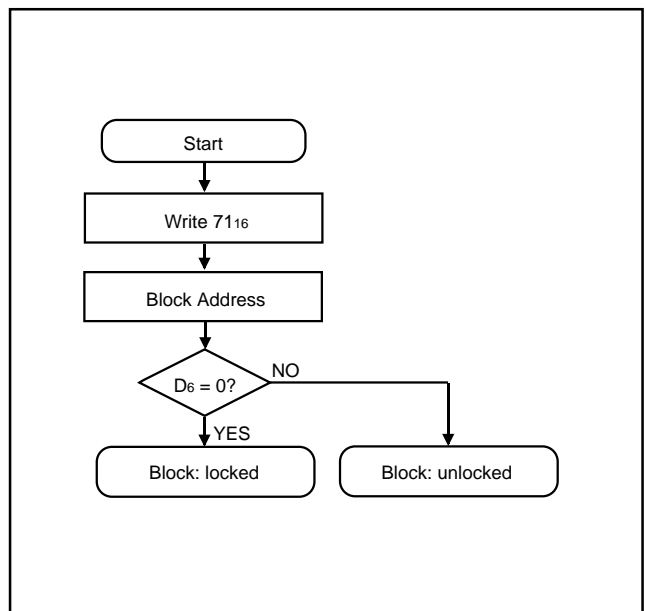

Fig. 119 Read lock bit status flowchart

MITSUBISHI MICROCOMPUTERS

# M37902FCCHP, M37902FGCHP, M37902FJCHP

SINGLE-CHIP 16-BIT CMOS MICROCOMPUTER

---

## Erase All Unlocked Block Command (A7<sub>16</sub>/D0<sub>16</sub>)

Writing command code "A7<sub>16</sub>" at the 1st bus cycle and writing verify command code "D0<sub>16</sub>" at the subsequent 2nd bus cycle initiate the continuous block erase (chip erase) operations for all the blocks.

The completion of the chip erase operation, as well as of the block erase operation, is verified by a read of the status register or a read of the flash memory control register. The result of the automatic erase operation is also reported by a read of the status register.

During the automatic erase operation (when the RY/ $\overline{\text{BY}}$  status bit = "0"), writing of commands and access to the flash memory must not be performed.

When the lock bit invalidity select bit = "1", all the blocks are erased regardless of the status of their lock bits. When the lock bit invalidity select bit = "0", on the contrary, the status of each lock bit becomes valid, so only the blocks in the unlocked state (lock bit = "1") are erased.

## Lock Bit Programming Command (77<sub>16</sub>/D0<sub>16</sub>)

By writing of command code "77<sub>16</sub>" at the 1st bus cycle and writing of verify command code "D0<sub>16</sub>" and the block's maximum address (Note that address A<sub>0</sub> = "0".) at the subsequent 2nd bus cycle, "0" (the locked state) is written into the lock bit of the specified block.

Figure 118 shows an example of the lock bit programming flowchart. The status of the lock bit can be read out by the read lock bit status command.

The completion of the lock bit programming operation, as well as of the page programming operation, is verified by a read of the status register or a read of the flash memory control register.

For details of the lock bit's function and the method of reset, refer to the section on the data protect function.

## Read Lock Bit Status Command (71<sub>16</sub>)

By writing of command code "71<sub>16</sub>" at the 1st bus cycle and writing of the block's maximum address (Note that address A<sub>0</sub> = "0".) at the subsequent 2nd bus cycle, the status of the lock bit of the specified block is output to the data bus (D<sub>6</sub>).

Figure 119 shows an example of the read lock bit programming flowchart.

## Data Protect Function (Block Lock)

Each block is implemented with a nonvolatile lock bit to protect the block from erasing/programming (block lock). A "0" (the locked state) can be written to a lock bit using the lock bit programming command, and the lock bit of each block can be read out by using the read lock bit status command.

Whether a block lock is valid or invalid is determined by the status of the lock bit and the lock bit invalidity select bit of the flash memory control register.

- (1) When the lock bit invalidity select bit = "0", a lock bit determines whether to lock or unlock the corresponding block. A block with its lock bit = "0" is locked and inhibited from erasing and programming. On the other hand, a block with its lock bit = "1" remains unlocked and allows to be erased/programmed.
- (2) When the lock bit invalidity select bit = "1", all the blocks are unlocked and allows to be erased/programmed regardless of the values of their lock bits. In this case, a lock bit with a value "0" (the locked state) is set to "1" (the unlocked state) after

completion of the erase operation, and the locked state by the lock bit is terminated.

To perform erase or programming, be sure to do one of the following.

- By executing the read lock bit status command, verify that the lock of the target block is invalid.
- Set the lock bit invalidity select bit to "1" to invalidate the lock.

When the block erase or programming is performed with the lock valid, the erase status bit (SR.5) and programming status bit (SR.4) are set to "1" (terminated by error).

## Status Register

The status register is used to indicate what the status of the write state machine (WSM) operation is and whether the programming/erase operation has been completed normally or terminated by an error. By writing the read status register command (70<sub>16</sub>), the contents of the status register can be read out; by writing the clear status register command (50<sub>16</sub>), the contents of the status register can be cleared.

Table 21 lists the definition of each bit of the status register.

The status register outputs "80<sub>16</sub>" after reset is removed.

The status of each bit is described below.

MITSUBISHI MICROCOMPUTERS

# M37902FCCHP, M37902FGCHP, M37902FJCHP

SINGLE-CHIP 16-BIT CMOS MICROCOMPUTER

### Write State Machine (WSM) Status Bit (SR.7)

This bit reports the operation status of the WSM. This bit is set to "1" (READY) after the system power is turned on or after reset is removed.

During the automatic programming or erase operation, this bit is cleared to "0" (BUSY), however, set to "1" upon completion of them.

### Erase Status Bit (SR.5)

This bit reports the status of the automatic erase operation. This bit is set to "1" if an erase error occurs and returns to "0" if one of the following conditions is satisfied:

- the system power is turned on.
- reset is removed.
- the clear status register command (50<sub>16</sub>) is executed.

### Programming Status Bit (SR.4)

This bit reports the status of the automatic programming operation. This bit is set to "1" if a programming error occurs and returns to "0" if one of the following conditions is satisfied:

- the system power is turned on.
- reset is removed.
- the clear status register command (50<sub>16</sub>) is executed.

### Block Status After Programming Bit (SR.3)

This bit is set to "1", upon completion of the page programming operation, if the excessive programming (**Note**) occurs. That is, the status register becomes "80<sub>16</sub>" when the programming operation is terminated normally, "90<sub>16</sub>" when the programming operation is failed, and "88<sub>16</sub>" when the excessive programming occurs.

Under the condition that any of SR.5, SR.4 and SR.3 = "1", none of the page programming, block erase, erase all unlocked block, and lock bit programming commands can be accepted. To execute these commands, in advance, execute the clear status register command (50<sub>16</sub>) to clear the status register.

Both of SR.4 and SR.5 are set to "1" under the following conditions (Command Sequence Error):

- (1) when data other than "D0<sub>16</sub>" and "FF<sub>16</sub>" is written to the data in the 2nd bus cycle of the lock bit programming command (77<sub>16</sub>/D0<sub>16</sub>)
- (2) when data other than "D0<sub>16</sub>" and "FF<sub>16</sub>" is written to the data in the 2nd bus cycle of the block erase command (20<sub>16</sub>/D0<sub>16</sub>)
- (3) when data other than "D0<sub>16</sub>" and "FF<sub>16</sub>" is written to the data in the 2nd bus cycle of the erase all unlocked block command (A7<sub>16</sub>/D0<sub>16</sub>)

Note that, writing of "FF<sub>16</sub>" forces the microcomputer into the read array mode. Simultaneously with this, the command written in the 1st bus cycle will be canceled.

**Note:** The excessive programming means the status that memory cells are too depleted, so data cannot be read out correctly.

### Full Status Check

The full status check reports the results of the erase or programming operation.

Figure 120 shows the full status check flowchart and actions to be taken if an error has occurred.

Table 21. Bit definition of status register

Symbol	Status	Definition	
		"1"	"0"
SR.7 (D7)	Write State Machine (WSM) Status	Ready	Busy
SR.6 (D6)	Reserved	—	—
SR.5 (D5)	Erase Status	Terminated by error.	Terminated normally.
SR.4 (D4)	Programming Status	Terminated by error.	Terminated normally.
SR.3 (D3)	Block Status After Programming	Terminated by error.	Terminated normally.
SR.2 (D2)	Reserved	—	—
SR.1 (D1)	Reserved	—	—
SR.0 (D0)	Reserved	—	—



MITSUBISHI MICROCOMPUTERS  
**M37902FCCHP, M37902FGCHP, M37902FJCHP**

SINGLE-CHIP 16-BIT CMOS MICROCOMPUTER

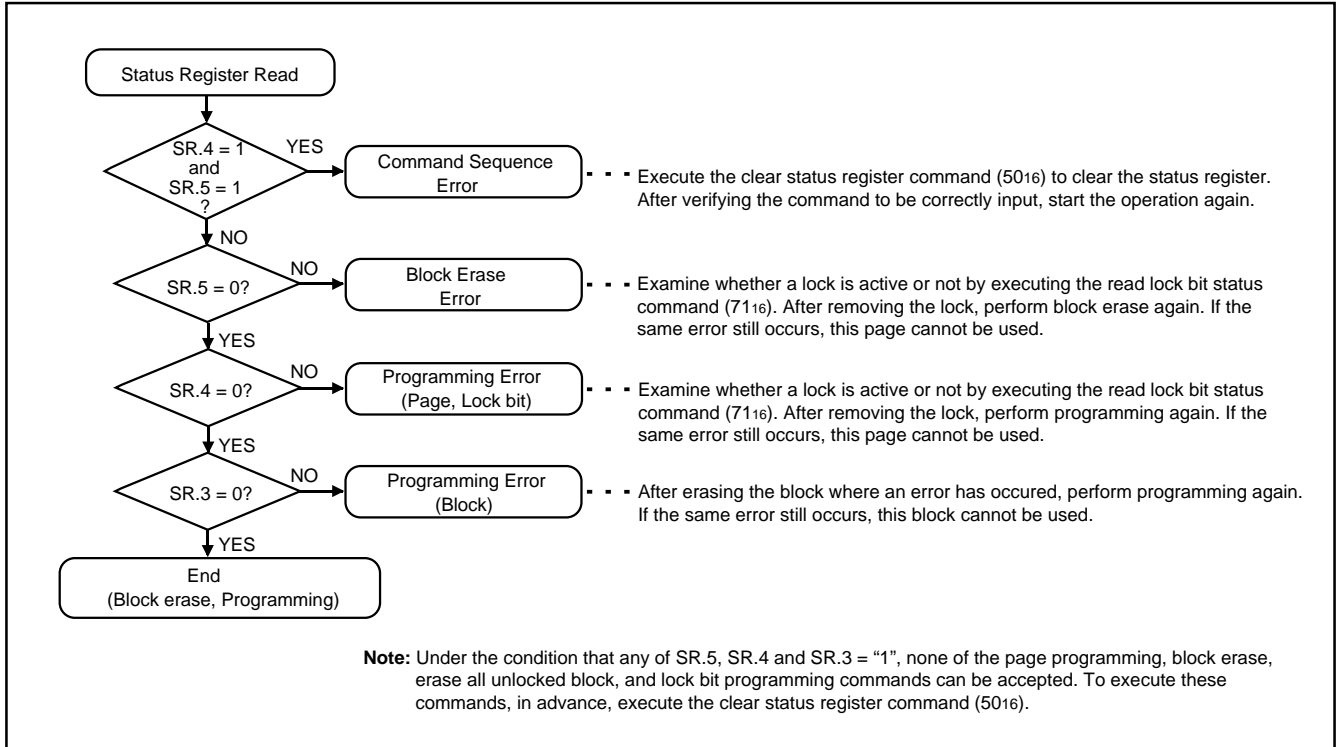

Fig. 120 Full status check flowchart and actions to be taken if an error has occurred

**DC Electrical Characteristics (V<sub>CC</sub> = 5 V ± 0.5 V, T<sub>a</sub> = 0 to 60 °C, f(f<sub>sys</sub>) = 26 MHz (Note))**

Symbol	Parameter	Limits			Unit
		Min.	Typ.	Max.	
I <sub>cc1</sub>	V <sub>CC</sub> power source current (at read)		30	48	mA
I <sub>cc2</sub>	V <sub>CC</sub> power source current (at write)			48	mA
I <sub>cc3</sub>	V <sub>CC</sub> power source current (at programming)			54	mA
I <sub>cc4</sub>	V <sub>CC</sub> power source current (at erasing)			54	mA

Limits of V<sub>IH</sub>, V<sub>IL</sub>, V<sub>OH</sub>, V<sub>OL</sub>, I<sub>IH</sub>, and I<sub>IL</sub> for each pin are the same as those in the microcomputer mode.

**Note:** f(f<sub>sys</sub>) indicates the system clock (f<sub>sys</sub>) frequency.

**AC Electrical Characteristics (V<sub>CC</sub> = 5 V ± 0.5 V, T<sub>a</sub> = 0 to 60 °C, f(f<sub>sys</sub>) = 26 MHz (Note))**

Parameter	Limits			Unit
	Min.	Typ.	Max.	
Page programming time		8	120	ms
Block erase time		50	600	ms
Erase all unlocked block time		50 × n	600 × n	ms
Lock bit programming time		8	120	ms

n = Number of blocks to be erased

The limits of parameters other than the above are same as those in the microcomputer mode.

**Note:** f(f<sub>sys</sub>) indicates the system clock (f<sub>sys</sub>) frequency.

MITSUBISHI MICROCOMPUTERS

# M37902FCCHP, M37902FGCHP, M37902FJCHP

SINGLE-CHIP 16-BIT CMOS MICROCOMPUTER

## ABSOLUTE MAXIMUM RATINGS

Symbol	Parameter	Ratings	Unit
V <sub>CC</sub>	Power source voltage	-0.3 to 6.5	V
AV <sub>CC</sub>	Analog power source voltage	-0.3 to 6.5	V
V <sub>I</sub>	Input voltage P00-P07, P10-P17, P20-P27, P30-P33, P40-P47, P50-P57, P60-P67, P70-P77, P80-P87, P100-P107, P110-P117, V <sub>REF</sub> , X <sub>IN</sub> , RESET, BYTE, MD0, MD1, NMI, V <sub>CONT</sub>	-0.3 to V <sub>CC</sub> +0.3	V
V <sub>O</sub>	Output voltage P00-P07, P10-P17, P20-P27, P30-P33, P40-P47, P50-P57, P60-P67, P70-P77, P80-P87, P100-P107, P110-P117, X <sub>OUT</sub>	-0.3 to V <sub>CC</sub> +0.3	V
P <sub>d</sub>	Power dissipation	400	mW
T <sub>opr</sub>	Operating ambient temperature	-20 to 85	°C
T <sub>stg</sub>	Storage temperature	-40 to 150	°C

## RECOMMENDED OPERATING CONDITIONS (V<sub>CC</sub> = 5 V, T<sub>a</sub> = -20 to 85 °C, unless otherwise noted)

Symbol	Parameter	Limits			Unit
		Min.	Typ.	Max.	
V <sub>CC</sub>	Power source voltage	4.5	5.0	5.5	V
AV <sub>CC</sub>	Analog power source voltage		V <sub>CC</sub>		V
V <sub>SS</sub>	Power source voltage		0		V
AV <sub>SS</sub>	Analog power source voltage		0		V
V <sub>IH</sub>	High-level input voltage X <sub>IN</sub> , RESET, BYTE, MD0, MD1	0.8 V <sub>CC</sub>		V <sub>CC</sub>	V
V <sub>IH</sub>	High-level input voltage P10-P17, P20-P27, P30-P33, P40-P47, P50-P57, P60-P67, P70-P77, P80-P87, P100-P107, P110-P117	0.7 V <sub>CC</sub>		V <sub>CC</sub>	V
V <sub>IH</sub>	High-level input voltage P00-P07 (When the port P0 input level select bit = "0")	0.7 V <sub>CC</sub>		V <sub>CC</sub>	V
V <sub>IH</sub>	High-level input voltage P00-P07 (When the port P0 input level select bit = "1")	0.43 V <sub>CC</sub>		V <sub>CC</sub>	V
V <sub>IH</sub>	High-level input voltage D0-D7, D8-D15	0.43 V <sub>CC</sub>		V <sub>CC</sub>	V
V <sub>IH</sub>	High-level input voltage RDY, HOLD, TA0IN-TA4IN, TA0OUT-TA4OUT, TB0IN-TB2IN, K10-K13, INT0-INT4, NMI, ADTRG, CTS0, CTS1, CLK0, CLK1, RxDo, RxD1	0.43 V <sub>CC</sub>		V <sub>CC</sub>	V
V <sub>IH</sub>	High-level input voltage SCLK, SDA ( <b>Note 1</b> )	0.43 V <sub>CC</sub>		V <sub>CC</sub>	V
V <sub>IH</sub>	Low-level input voltage X <sub>IN</sub> , RESET, BYTE, MD0, MD1	0		0.2 V <sub>CC</sub>	V
V <sub>IL</sub>	Low-level input voltage P10-P17, P20-P27, P30-P33, P40-P47, P50-P57, P60-P67, P70-P77, P80-P87, P100-P107, P110-P117	0		0.2 V <sub>CC</sub>	V
V <sub>IL</sub>	Low-level input voltage P00-P07 (When the port P0 input level select bit = "0")	0		0.2 V <sub>CC</sub>	V
V <sub>IL</sub>	Low-level input voltage P00-P07 (When the port P0 input level select bit = "1")	0		0.16 V <sub>CC</sub>	V
V <sub>IL</sub>	Low-level input voltage D0-D7, D8-D15	0		0.16 V <sub>CC</sub>	V
V <sub>IL</sub>	Low-level input voltage RDY, HOLD, TA0IN-TA4IN, TA0OUT-TA4OUT, TB0IN-TB2IN, K10-K13, INT0-INT4, NMI, ADTRG, CTS0, CTS1, CLK0, CLK1, RxDo, RxD1	0		0.16 V <sub>CC</sub>	V
V <sub>IL</sub>	Low-level input voltage SCLK, SDA ( <b>Note 1</b> )	0		0.16 V <sub>CC</sub>	V
I <sub>OH(peak)</sub>	High-level peak output current P00-P07, P10-P17, P20-P27, P30-P33, P40-P47, P50-P57, P60-P67, P70-P77, P80-P87, P100-P107, P110-P117			-10	mA
I <sub>OH(avg)</sub>	High-level average output current P00-P07, P10-P17, P20-P27, P30-P33, P40-P47, P50-P57, P60-P67, P70-P77, P80-P87, P100-P107, P110-P117			-5	mA
I <sub>OL(peak)</sub>	Low-level peak output current P00-P07, P10-P17, P20-P27, P30-P33, P40-P47, P50-P57, P60-P67, P70-P77, P80-P87, P100-P107, P110-P117			10	mA
I <sub>OL(avg)</sub>	Low-level average output current P00-P07, P10-P17, P20-P27, P30-P33, P40-P47, P50-P57, P60-P67, P70-P77, P80-P87, P100-P107, P110-P117			5	mA
f(X <sub>IN</sub> )	External clock input frequency ( <b>Note 2</b> )			26	MHz
f(f <sub>sys</sub> )	System clock frequency			26	MHz

**Notes 1:** Pins SCLK and SDA are used only in the flash memory serial I/O mode.

**2:** When using the PLL frequency multiplier, be sure that f(f<sub>sys</sub>) = 26 MHz or less.

**3:** Average output current is the average value of an interval of 100 ms.

**4:** The sum of I<sub>OL(peak)</sub> for ports P0-P2, P8, P10, and P11 must be 80 mA or less, the sum of I<sub>OH(peak)</sub> for ports P0-P2, P8, P10, and P11 must be 80 mA or less, the sum of I<sub>OL(peak)</sub> for ports P3-P7 must be 80 mA or less, the sum of I<sub>OH(peak)</sub> for ports P3-P7 must be 80 mA or less.

MITSUBISHI MICROCOMPUTERS

# M37902FCCHP, M37902FGCHP, M37902FJCHP

SINGLE-CHIP 16-BIT CMOS MICROCOMPUTER

## DC ELECTRICAL CHARACTERISTICS (V<sub>CC</sub> = 5 V, V<sub>SS</sub> = 0 V, T<sub>a</sub> = -20 to 85 °C, f<sub>(fsys)</sub> = 26 MHz (Note))

Symbol	Parameter	Test conditions	Limits			Unit	
			Min.	Typ.	Max.		
VOH	High-level output voltage P00-P07, P10-P17, P20-P27, P30, P40-P47, P50-P57, P60-P67, P70-P77, P80-P87, P100-P107, P110-P117	I <sub>OH</sub> = -10 mA	3			V	
VOH	High-level output voltage P00-P07, P10-P17, P20-P27, P40, P42, P44-P47, P100-P107, P110-P117	I <sub>OH</sub> = -400 μA	4.7			V	
VOH	High-level output voltage P31-P33	I <sub>OH</sub> = -10 mA	3.4			V	
		I <sub>OH</sub> = -400 μA	4.8				
VOL	Low-level output voltage P00-P07, P10-P17, P20-P27, P30, P40-P47, P50-P57, P60-P67, P70-P77, P80-P87, P100-P107, P110-P117	I <sub>OL</sub> = 10 mA			2	V	
VOL	Low-level output voltage P00-P07, P10-P17, P20-P27, P40, P42, P44-P47, P100-P107, P110-P117	I <sub>OL</sub> = 2 mA			0.45	V	
VOL	Low-level output voltage P31-P33	I <sub>OL</sub> = 10 mA			1.6	V	
		I <sub>OL</sub> = 2 mA			0.4		
VT+ -VT-	Hysteresis $\overline{RDY}$ , $\overline{HOLD}$ , TA0IN-TA4IN, TA0OUT-TA4OUT, TB0IN-TB2IN, KI0-KI3, INT0-INT4, NMI, ADTRG, CTS0, CTS1, CLK0, CLK1, RxD0, RxD1		0.2		0.7	V	
VT+ -VT-	Hysteresis $\overline{RESET}$		0.5		1.5	V	
VT+ -VT-	Hysteresis X <sub>IN</sub>		0.1		0.3	V	
I <sub>IH</sub>	High-level input current P00-P07, P10-P17, P20-P27, P30-P33, P40-P47, P50-P57, P60-P67, P70-P77, P80-P87, P100-P107, P110-P117, X <sub>IN</sub> , $\overline{RESET}$ , BYTE, MD0, MD1, NMI	V <sub>I</sub> = 5.0 V			5	μA	
I <sub>IL</sub>	Low-level input current P00-P07, P10-P17, P20-P27, P30-P33, P40-P43, P50-P53, P60-P67, P70-P77, P80-P87, P100-P107, P110-P117, X <sub>IN</sub> , $\overline{RESET}$ , BYTE, MD0, MD1	V <sub>I</sub> = 0 V			-5	μA	
I <sub>IL</sub>	Low-level input current P44-P47, P54-P57, $\overline{NMI}$	V <sub>I</sub> = 0 V, No pullup transistor			-5	μA	
		V <sub>I</sub> = 0 V, Pullup transistor used	-0.4	-0.7	-1.1	mA	
VRAM	RAM hold voltage	When clock is stoped.	2			V	
ICC	Power source current	Output-only pins are open, and the other pins are connected to V <sub>SS</sub> or V <sub>CC</sub> . An external square-waveform clock is input. (Pin X <sub>OUT</sub> is open.) The PLL frequency multiplier stops its operation.	f <sub>(fsys)</sub> = 26 MHz. CPU operates.	30	54	mA	
			T <sub>a</sub> = 25 °C when clock is stoped.			1	μA
			T <sub>a</sub> = 85 °C when clock is stoped.			20	

MITSUBISHI MICROCOMPUTERS

# M37902FCCHP, M37902FGCHP, M37902FJCHP

SINGLE-CHIP 16-BIT CMOS MICROCOMPUTER

## A-D CONVERTER CHARACTERISTICS

( $V_{CC} = AV_{CC} = 5\text{ V} \pm 0.5\text{ V}$ ,  $V_{SS} = AV_{SS} = 0\text{ V}$ ,  $T_a = -20\text{ to }85\text{ }^\circ\text{C}$ , unless otherwise noted)

Symbol	Parameter	Test conditions	Limits		Unit
			Min.	Max.	
—	Resolution	$V_{REF} = V_{CC}$		10	Bits
—	Absolute accuracy	$V_{REF} = V_{CC}$	10-bit resolution mode	$\pm 3$	LSB
			8-bit resolution mode	$\pm 2$	LSB
RLADDER	Ladder resistance	$V_{REF} = V_{CC}$	5		k $\Omega$
tCONV	Conversion time	$f(f_{sys}) \leq 26\text{ MHz}$	10-bit resolution mode	4.54	$\mu\text{s}$
			8-bit resolution mode	1.89 (Note)	
VREF	Reference voltage		2.7	$V_{CC}$	V
VIA	Analog input voltage		0	$V_{REF}$	V

Note: This is applied when A-D conversion frequency ( $\phi_{AD}$ ) =  $f_1$ .

## D-A CONVERTER CHARACTERISTICS

( $V_{CC} = 5\text{ V}$ ,  $V_{SS} = AV_{SS} = 0\text{ V}$ ,  $V_{REF} = 5\text{ V}$ ,  $T_a = -20\text{ to }85\text{ }^\circ\text{C}$ , unless otherwise noted)

Symbol	Parameter	Test conditions	Limits			Unit
			Min.	Typ.	Max.	
—	Resolution				8	Bits
—	Absolute accuracy				$\pm 1.0$	%
t <sub>su</sub>	Set time				3	$\mu\text{s}$
RO	Output resistance		1	2.5	4	k $\Omega$
I <sub>VREF</sub>	Reference power source input current	(Note)			3.2	mA

Note: The test conditions are as follows:

- One D-A converter is used.
- The D-A register value of the unused D-A converter is "0016."
- The reference power source input current for the ladder resistance of the A-D converter is excluded.

## RESET INPUT

**Reset input timing requirements** ( $V_{CC} = 5\text{ V} \pm 0.5\text{ V}$ ,  $V_{SS} = 0\text{ V}$ ,  $T_a = -20\text{ to }85\text{ }^\circ\text{C}$ , unless otherwise noted)

Symbol	Parameter	Limits			Unit
		Min.	Typ.	Max.	
t <sub>w</sub> (RESETL)	RESET input low-level pulse width	2			$\mu\text{s}$

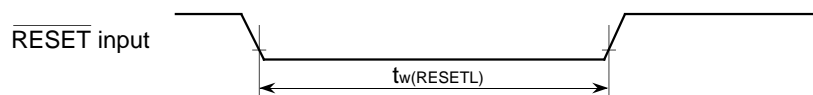

MITSUBISHI MICROCOMPUTERS

# M37902FCCHP, M37902FGCHP, M37902FJCHP

SINGLE-CHIP 16-BIT CMOS MICROCOMPUTER

## PERIPHERAL DEVICE INPUT/OUTPUT TIMING

( $V_{CC} = 5 V \pm 0.5 V$ ,  $V_{SS} = 0 V$ ,  $T_a = -20$  to  $85^\circ C$ ,  $f(f_{sys}) = 26$  MHz unless otherwise noted)

\* For limits depending on  $f(f_{sys})$ , their calculation formulas are shown below. Also, the values at  $f(f_{sys}) = 26$  MHz are shown in ( ).

### Timer A input (Count input in event counter mode)

Symbol	Parameter	Limits		Unit
		Min.	Max.	
$t_c(TA)$	TAiIN input cycle time	80		ns
$t_w(TAH)$	TAiIN input high-level pulse width	40		ns
$t_w(TAL)$	TAiIN input low-level pulse width	40		ns

### Timer A input (Gating input in timer mode)

Symbol	Parameter		Limits		Unit
			Min.	Max.	
$t_c(TA)$	TAiIN input cycle time	$f(f_{sys}) \leq 26$ MHz	$\frac{16 \times 10^9}{f(f_{sys})}$ (615)		ns
$t_w(TAH)$	TAiIN input high-level pulse width	$f(f_{sys}) \leq 26$ MHz	$\frac{8 \times 10^9}{f(f_{sys})}$ (307)		ns
$t_w(TAL)$	TAiIN input low-level pulse width	$f(f_{sys}) \leq 26$ MHz	$\frac{8 \times 10^9}{f(f_{sys})}$ (307)		ns

**Note** : The TAiIN input cycle time requires 4 or more cycles of a count source. The TAiIN input high-level pulse width and the TAiIN input low-level pulse width respectively require 2 or more cycles of a count source. The limits in this table are applied when the count source = f2 at  $f(f_{sys}) \leq 26$  MHz.

### Timer A input (External trigger input in one-shot pulse mode)

Symbol	Parameter		Limits		Unit
			Min.	Max.	
$t_c(TA)$	TAiIN input cycle time	$f(f_{sys}) \leq 26$ MHz	$\frac{8 \times 10^9}{f(f_{sys})}$ (307)		ns
$t_w(TAH)$	TAiIN input high-level pulse width		80		ns
$t_w(TAL)$	TAiIN input low-level pulse width		80		ns

### Timer A input (External trigger input in pulse width modulation mode)

Symbol	Parameter	Limits		Unit
		Min.	Max.	
$t_w(TAH)$	TAiIN input high-level pulse width	80		ns
$t_w(TAL)$	TAiIN input low-level pulse width	80		ns

### Timer A input (Up-down input and Count input in event counter mode)

Symbol	Parameter	Limits		Unit
		Min.	Max.	
$t_c(UP)$	TAiOUT input cycle time	2000		ns
$t_w(UPH)$	TAiOUT input high-level pulse width	1000		ns
$t_w(UPL)$	TAiOUT input low-level pulse width	1000		ns
$t_{su}(UP-TIN)$	TAiOUT input setup time	400		ns
$t_h(TIN-UP)$	TAiOUT input hold time	400		ns

MITSUBISHI MICROCOMPUTERS

# M37902FCCHP, M37902FGCHP, M37902FJCHP

SINGLE-CHIP 16-BIT CMOS MICROCOMPUTER

### Timer A input (Two-phase pulse input in event counter mode)

Symbol	Parameter	Limits		Unit
		Min.	Max.	
$t_c(TA)$	TAiin input cycle time	800		ns
$t_{su}(TA_{jIN}-TA_{jOUT})$	TAjIN input setup time	200		ns
$t_{su}(TA_{jOUT}-TA_{jIN})$	TAjOUT input setup time	200		ns

- Gating input in timer mode
- Count input in event counter mode
- External trigger input in one-shot pulse mode
- External trigger input in pulse width modulation mode

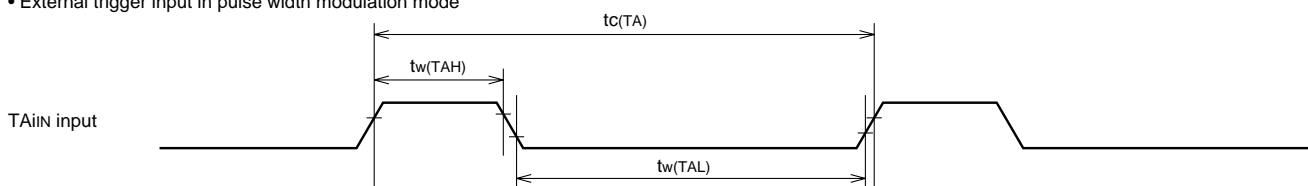

- Up-down and Count input in event counter mode

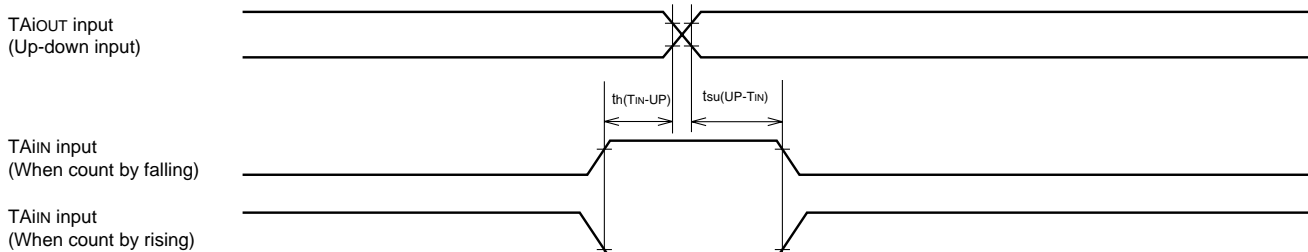
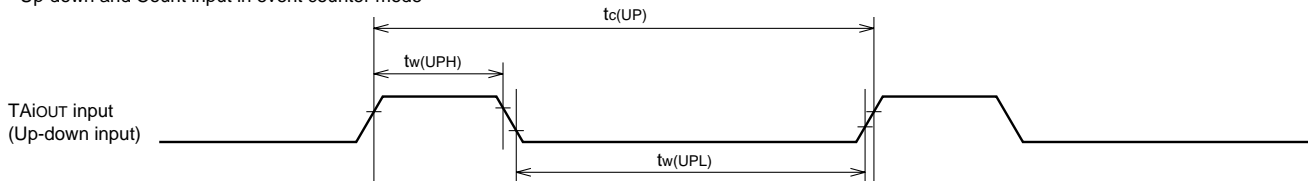

- Two-phase pulse input in event counter mode

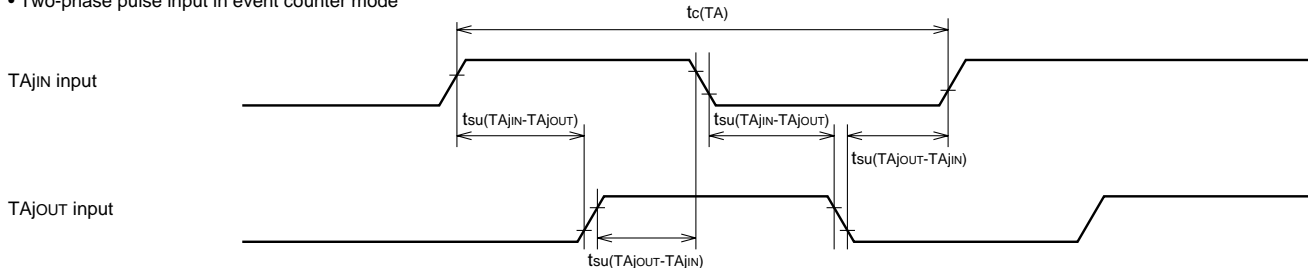

#### Test conditions

- $V_{CC} = 5 V \pm 0.5 V$ ,  $T_a = -20$  to  $85$  °C
- Input timing voltage :  $V_{IL} = 0.8 V$ ,  $V_{IH} = 2.15 V$

MITSUBISHI MICROCOMPUTERS

# M37902FCCHP, M37902FGCHP, M37902FJCHP

SINGLE-CHIP 16-BIT CMOS MICROCOMPUTER

## Timer B input (Count input in event counter mode)

Symbol	Parameter	Limits		Unit
		Min.	Max.	
t <sub>c</sub> (TB)	TBiIN input cycle time (one edge count)	80		ns
t <sub>w</sub> (TBH)	TBiIN input high-level pulse width (one edge count)	40		ns
t <sub>w</sub> (TBL)	TBiIN input low-level pulse width (one edge count)	40		ns
t <sub>c</sub> (TB)	TBiIN input cycle time (both edge count)	160		ns
t <sub>w</sub> (TBH)	TBiIN input high-level pulse width (both edge count)	80		ns
t <sub>w</sub> (TBL)	TBiIN input low-level pulse width (both edge count)	80		ns

## Timer B input (Pulse period measurement mode)

Symbol	Parameter		Limits		Unit
			Min.	Max.	
t <sub>c</sub> (TB)	TBiIN input cycle time	f(f <sub>sys</sub> ) ≤ 26 MHz	$\frac{16 \times 10^9}{f(f_{sys})}$ (615)		ns
t <sub>w</sub> (TBH)	TBiIN input high-level pulse width	f(f <sub>sys</sub> ) ≤ 26 MHz	$\frac{8 \times 10^9}{f(f_{sys})}$ (307)		ns
t <sub>w</sub> (TBL)	TBiIN input low-level pulse width	f(f <sub>sys</sub> ) ≤ 26 MHz	$\frac{8 \times 10^9}{f(f_{sys})}$ (307)		ns

**Note:** The TBiIN input cycle time requires 4 or more cycles of a count source. The TBiIN input high-level pulse width and the TBiIN input low-level pulse width respectively require 2 or more cycles of a count source. The limits in this table are applied when the count source = f<sub>2</sub> at f(f<sub>sys</sub>) ≤ 26 MHz.

## Timer B input (Pulse width measurement mode)

Symbol	Parameter		Limits		Unit
			Min.	Max.	
t <sub>c</sub> (TB)	TBiIN input cycle time	f(f <sub>sys</sub> ) ≤ 26 MHz	$\frac{16 \times 10^9}{f(f_{sys})}$ (615)		ns
t <sub>w</sub> (TBH)	TBiIN input high-level pulse width	f(f <sub>sys</sub> ) ≤ 26 MHz	$\frac{8 \times 10^9}{f(f_{sys})}$ (307)		ns
t <sub>w</sub> (TBL)	TBiIN input low-level pulse width	f(f <sub>sys</sub> ) ≤ 26 MHz	$\frac{8 \times 10^9}{f(f_{sys})}$ (307)		ns

**Note:** The TBiIN input cycle time requires 4 or more cycles of a count source. The TBiIN input high-level pulse width and the TBiIN input low-level pulse width respectively require 2 or more cycles of a count source. The limits in this table are applied when the count source = f<sub>2</sub> at f(f<sub>sys</sub>) ≤ 26 MHz.

## A-D trigger input

Symbol	Parameter	Limits		Unit
		Min.	Max.	
t <sub>c</sub> (AD)	ADTRG input cycle time (minimum allowable trigger)	1000		ns
t <sub>w</sub> (ADL)	ADTRG input low-level pulse width	125		ns

MITSUBISHI MICROCOMPUTERS

# M37902FCCHP, M37902FGCHP, M37902FJCHP

SINGLE-CHIP 16-BIT CMOS MICROCOMPUTER

## Serial I/O

Symbol	Parameter	Limits		Unit
		Min.	Max.	
$t_c(\text{CK})$	CLKi input cycle time	200		ns
$t_w(\text{CKH})$	CLKi input high-level pulse width	100		ns
$t_w(\text{CKL})$	CLKi input low-level pulse width	100		ns
$t_d(\text{C-Q})$	TxDi output delay time		80	ns
$t_h(\text{C-Q})$	TxDi hold time	0		ns
$t_{su}(\text{D-C})$	RxDi input setup time	20		ns
$t_h(\text{C-D})$	RxDi input hold time	90		ns

## External interrupt ( $\overline{\text{INTi}}$ ) input, $\overline{\text{NMI}}$ input, Key input interrupt ( $\overline{\text{Kli}}$ ) input

Symbol	Parameter	Limits		Unit
		Min.	Max.	
$t_w(\text{INH})$	$\overline{\text{INTi}}$ input/ $\overline{\text{NMI}}$ input/ $\overline{\text{Kli}}$ input high-level pulse width	250		ns
$t_w(\text{INL})$	$\overline{\text{INTi}}$ input/ $\overline{\text{NMI}}$ input/ $\overline{\text{Kli}}$ input low-level pulse width	250		ns

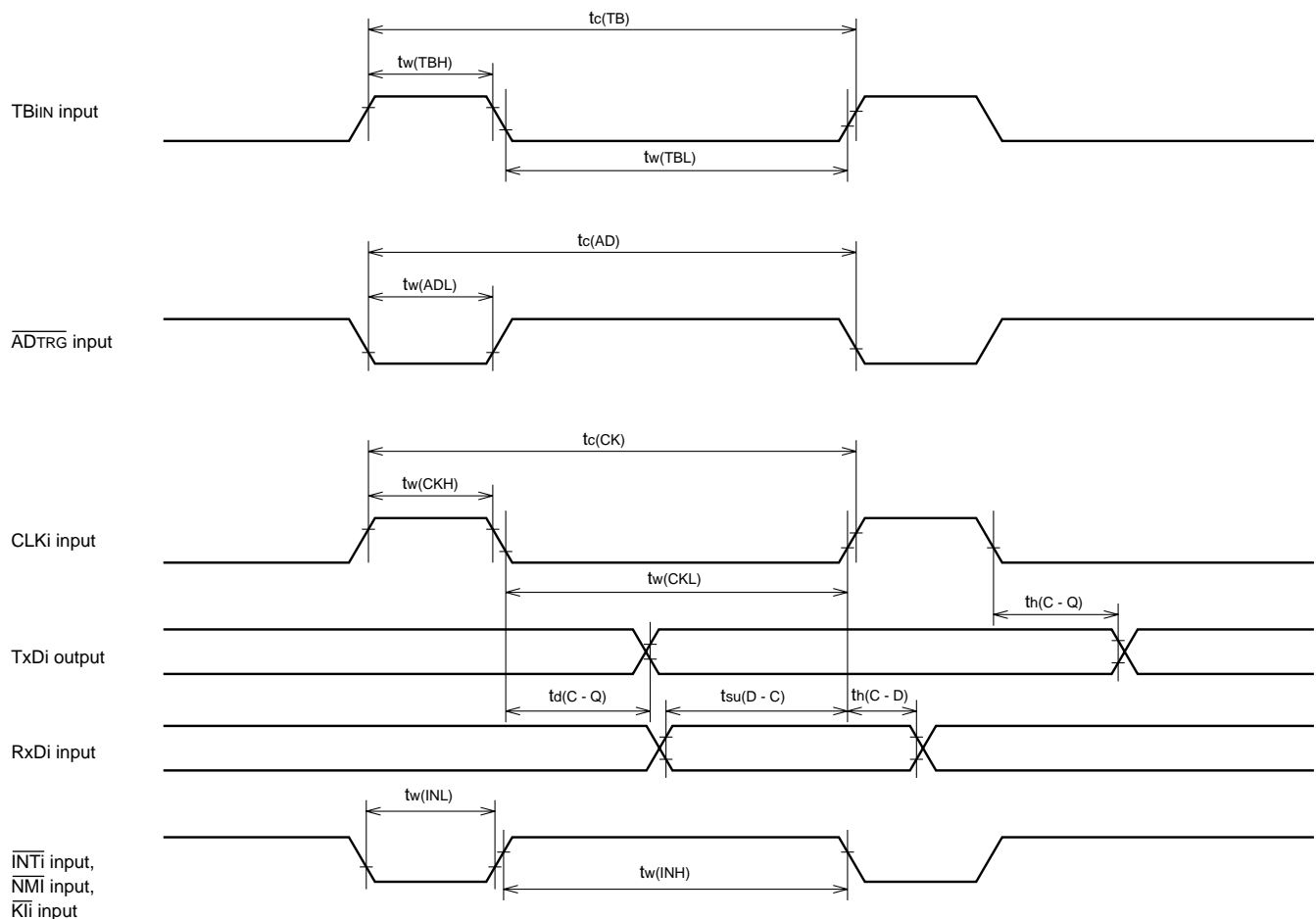

**Test conditions**

- $V_{cc} = 5\text{ V} \pm 0.5\text{ V}$ ,  $T_a = -20\text{ to }85\text{ }^\circ\text{C}$
- Input timing voltage :  $V_{IL} = 0.8\text{ V}$ ,  $V_{IH} = 2.15\text{ V}$
- Output timing voltage :  $V_{OL} = 0.8\text{ V}$ ,  $V_{OH} = 2.0\text{ V}$ ,  $C_L = 50\text{ pF}$



MITSUBISHI MICROCOMPUTERS

# M37902FCCHP, M37902FGCHP, M37902FJCHP

SINGLE-CHIP 16-BIT CMOS MICROCOMPUTER

## READY, HOLD TIMING

**Timing requirements** ( $V_{CC} = 5 V \pm 0.5 V$ ,  $V_{SS} = 0 V$ ,  $T_a = -20$  to  $85\text{ }^\circ\text{C}$ ,  $f(f_{sys}) = 26\text{ MHz}$ , unless otherwise noted)

Symbol	Parameter	Limits		Unit
		Min.	Max.	
$t_{su}(\text{RDY}-\phi 1)$	$\overline{\text{RDY}}$ input setup time	40		ns
$t_{su}(\text{HOLD}-\phi 1)$	$\overline{\text{HOLD}}$ input setup time	40		ns
$t_{h}(\phi 1-\text{RDY})$	$\overline{\text{RDY}}$ input hold time	0		ns
$t_{h}(\phi 1-\text{HOLD})$	$\overline{\text{HOLD}}$ input hold time	0		ns

**Switching characteristics** ( $V_{CC} = 5 V \pm 0.5 V$ ,  $V_{SS} = 0 V$ ,  $T_a = -20$  to  $85\text{ }^\circ\text{C}$ ,  $f(f_{sys}) = 26\text{ MHz}$ , unless otherwise noted)

Symbol	Parameter	Limits		Unit
		Min.	Max.	
$t_{d}(\phi 1-\text{HLDAL})$	$\overline{\text{HLD}}\overline{\text{A}}$ output delay time		20	ns
$t_{d}(\text{RDH}-\text{HLDAL})$	$\overline{\text{HLD}}\overline{\text{A}}$ low-level output delay time after read	$t_c - 15$ (Note)		ns
$t_{d}(\text{BXWH}-\text{HLDAL})$	$\overline{\text{HLD}}\overline{\text{A}}$ low-level output delay time after write	$t_c - 15$ (Note)		ns
$t_{pxz}(\text{HLDAL}-\text{RDZ})$	Floating start delay time	-15	10	ns
$t_{pxz}(\text{HLDAL}-\text{BXWZ})$	Floating start delay time	-15	10	ns
$t_{pxz}(\text{HLDAL}-\text{CSIZ})$	Floating start delay time	-15	10	ns
$t_{pxz}(\text{HLDAL}-\text{ALEZ})$	Floating start delay time	-15	10	ns
$t_{pxz}(\text{HLDAL}-\text{AZ})$	Floating start delay time	-15	10	ns
$t_{pxz}(\text{HLDAL}-\text{RDZ})$	Floating release delay time	0		ns
$t_{pxz}(\text{HLDAL}-\text{BXWZ})$	Floating release delay time	0		ns
$t_{pxz}(\text{HLDAL}-\text{CSIZ})$	Floating release delay time	0		ns
$t_{pxz}(\text{HLDAL}-\text{ALEZ})$	Floating release delay time	0		ns
$t_{pxz}(\text{HLDAL}-\text{AZ})$	Floating release delay time	0		ns

**Note:**  $t_c = 1/f(f_{sys})$ .

MITSUBISHI MICROCOMPUTERS  
**M37902FCCHP, M37902FGCHP, M37902FJCHP**

SINGLE-CHIP 16-BIT CMOS MICROCOMPUTER

**$\overline{\text{RDY}}$  input**

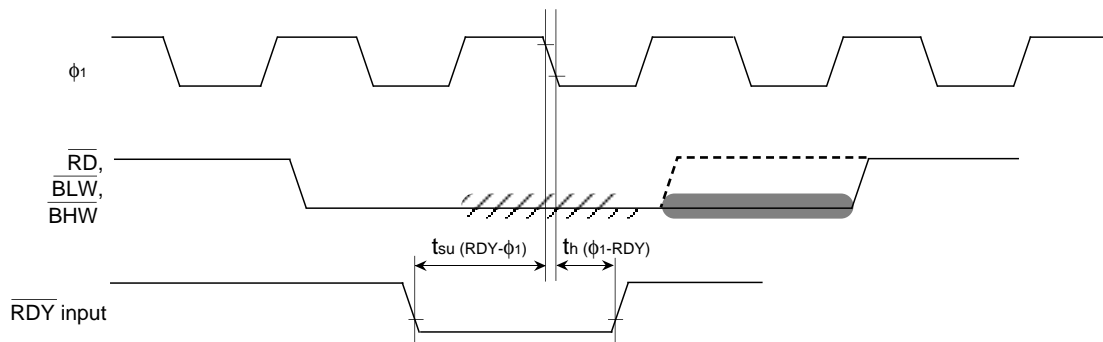

//// : Wait inserted by software (The above is applied when bus cycle =  $1\phi + 2\phi$ )

■ : Wait inserted by ready function

**$\overline{\text{HOLD}}$  input**

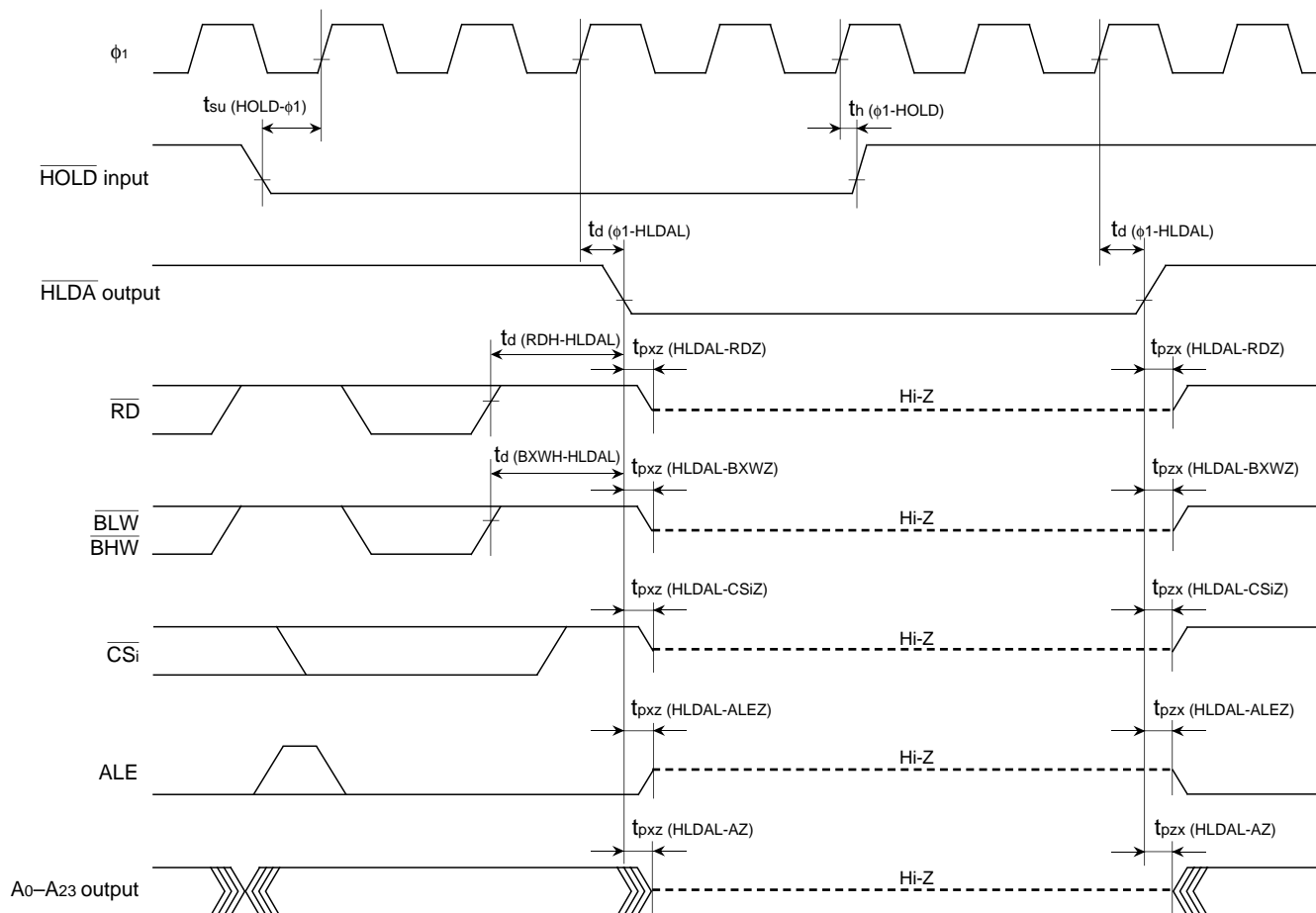

**Test conditions**

- $V_{CC} = 5 \text{ V} \pm 0.5 \text{ V}$ ,  $T_a = -20 \text{ to } 85 \text{ }^\circ\text{C}$
- $\overline{\text{RDY}}$  input,  $\overline{\text{HOLD}}$  input :  $V_{IL} = 0.8 \text{ V}$ ,  $V_{IH} = 2.15 \text{ V}$
- HLDA output :  $V_{OL} = 0.8 \text{ V}$ ,  $V_{OH} = 2.0 \text{ V}$ ,  $C_L = 50 \text{ pF}$

MITSUBISHI MICROCOMPUTERS

# M37902FCCHP, M37902FGCHP, M37902FJCHP

SINGLE-CHIP 16-BIT CMOS MICROCOMPUTER

## External bus timing

For limits depending on  $f(f_{sys})$ , their calculation formulas are shown below.

Bus cycle	WH	WL	Bus cycle	WH	WL
$1\phi + 1\phi$	1	1	$2\phi + 3\phi$	2	3
$1\phi + 2\phi$	1	2	$2\phi + 4\phi$	2	4
$1\phi + 3\phi$	1	3	$3\phi + 3\phi$	3	3
$2\phi + 2\phi$	2	2	$3\phi + 4\phi$	3	4

$t_c = 1/f(f_{sys})$ .

**Timing Requirements** ( $V_{CC} = 5 V \pm 0.5 V$ ,  $V_{SS} = 0 V$ ,  $T_a = -20$  to  $85^\circ C$ ,  $f(X_{IN}) = 26$  MHz, unless otherwise noted)

Symbol	Parameter	Limits		Unit
		Min.	Max.	
$t_{c(in)}$	External clock input cycle time	38		ns
$t_{w(half)}$	External clock input pulse width with half input-voltage	$0.45 t_c$	$0.55 t_c$	ns
$t_{w(H)}$	External clock input high-level pulse width	$0.5 t_c - 6$		ns
$t_{w(L)}$	External clock input low-level pulse width	$0.5 t_c - 6$		ns
$t_r$	External clock input rise time	6		ns
$t_f$	External clock input fall time	6		ns
$t_{a(A-D)}$	Address access time (the address output select bit = 0)		$(W_H + W_L) t_c - 45$	ns
$t_{a(A-D)}$	Address access time (the address output select bit = 1)		$(W_H + W_L - 0.5) t_c - 35$	ns
$t_{a(CSiL-D)}$	Chip select access time		$(W_H + W_L - 0.5) t_c - 35$	ns
$t_{a(RDL-D)}$	Read access time		$W_L \times t_c - 30$	ns
$t_{su(D-RDL)}$	Read data setup time	15		ns
$t_{h(RDH-D)}$	Data input hold time after read	0		ns
$t_{a(BA-D)}$	Address access time at burst ROM access		$W_L \times t_c - 35$	ns
$t_{h(BA-D)}$	Data hold time after address at burst ROM access	8		ns
$t_{a(LA-D)}$	Address access time (the multiplexed bus select bit = 1)		$(W_H + W_L - 0.5) t_c - 35$ (Note)	ns

**Note:** This is independent of the address output select bit's contents.

### External clock input

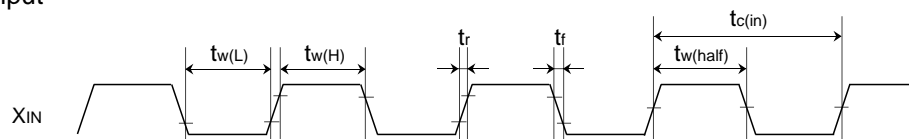

### Test conditions

- $V_{CC} = 5 V \pm 0.5 V$ ,  $T_a = -20$  to  $85^\circ C$
- Input timing voltage :  $V_{IL} = 1.0 V$ ,  $V_{IH} = 4.0 V$  ( $t_{w(H)}$ ,  $t_{w(L)}$ ,  $t_r$ ,  $t_f$ )
- Output timing voltage :  $2.5 V$  ( $t_{c(in)}$ ,  $t_{w(half)}$ )

MITSUBISHI MICROCOMPUTERS

# M37902FCCHP, M37902FGCHP, M37902FJCHP

SINGLE-CHIP 16-BIT CMOS MICROCOMPUTER

**Switching characteristics** ( $V_{CC} = 5 V \pm 0.5 V$ ,  $V_{SS} = 0 V$ ,  $T_a = -20$  to  $85$  °C,  $f(f_{sys}) = 26$  MHz, unless otherwise noted)

Symbol	Parameter		Limits		Unit
			Min.	Max.	
$t_{d(\phi 1-RDL)}$	Read low-level output delay time		-18	0	ns
$t_{d(\phi 1-RDH)}$	Read high-level output delay time		-18	0	ns
$t_{d(\phi 1-BXWL)}$	Write low-level output delay time		-18	0	ns
$t_{d(\phi 1-BXWH)}$	Write high-level output delay time		-18	0	ns
$t_{d(\phi 1L-CSiL)}$	Chip select low-level output delay time		-20	0	ns
$t_{d(\phi 1L-CSiH)}$	Chip select high-level output delay time		-22	10	ns
$t_{d(\phi 1H-A)}$	Address output delay time (the address output select bit = 0)		-5	25	ns
$t_{d(\phi 1L-A)}$	Address output delay time (the address output select bit = 1)		-20	16	ns
$t_w(ALEH)$	ALE pulse width	Bus cycle = $1\phi + 1\phi$ , $1\phi + 2\phi$ , $1\phi + 3\phi$	0.5tc-19		ns
		Bus cycle = $2\phi + 2\phi$	tc-20		ns
		Bus cycle = $2\phi + 3\phi$ , $2\phi + 4\phi$ , $3\phi + 3\phi$ , $3\phi + 4\phi$	1.5tc-20		ns
$t_{d(A-ALEL)}$	ALE completion delay time after address stabilization (when the address output select bit = 0)	Bus cycle = $1\phi + 1\phi$ , $1\phi + 2\phi$ , $1\phi + 3\phi$	tc-30		ns
		Bus cycle = $2\phi + 2\phi$	1.5tc-30		ns
		Bus cycle = $2\phi + 3\phi$ , $2\phi + 4\phi$ , $3\phi + 3\phi$ , $3\phi + 4\phi$	2tc-30		ns
	ALE completion delay time after address stabilization (when the address output select bit = 1)	Bus cycle = $1\phi + 1\phi$ , $1\phi + 2\phi$ , $1\phi + 3\phi$	0.5tc-19		ns
		Bus cycle = $2\phi + 2\phi$	tc-20		ns
		Bus cycle = $2\phi + 3\phi$ , $2\phi + 4\phi$ , $3\phi + 3\phi$ , $3\phi + 4\phi$	1.5tc-20		ns
$t_w(RDL)$	Read output pulse width		WL X tc-15		ns
$t_w(RDH)$	Read output high-level width <b>(Note 1)</b>		WH X tc-15		ns
$t_{d(RDH-BXWH)}$	Write disable valid time after read <b>(Note 2)</b>		tc-15		ns
$t_{d(A-RDH)}$	Address valid time before read (when the address output select bit = 0)		WH X tc-30		ns
$t_{d(A-RDH)}$	Address valid time before read (when the address output select bit = 1)		(WH-0.5)tc-19		ns
$t_{h(RDH-A)}$	Address hold time after read (when the address output select bit = 0) <b>(Note 2)</b>		8		ns
$t_{h(RDH-A)}$	Address hold time after read (when the address output select bit = 1) <b>(Note 2)</b>		0.5tc-10		ns
$t_{d(RDH-ALEL)}$	ALE completion delay time after read start			20	ns
$t_{d(ALEL-RDH)}$	Read disable valid time after ALE completion	Bus cycle = $2\phi + 2\phi$	0.5tc-19		ns
		Bus cycle = $3\phi + 3\phi$ , $3\phi + 4\phi$	tc-15		ns
$t_{d(CSiL-RDH)}$	Chip select valid time before read		(WH-0.5)tc-19		ns
$t_{d(CSiL-RDL)}$	Chip select output valid time before read completion		(WH + WL-0.5)tc-20		ns
$t_{h(RDH-CSiL)}$	Chip select hold time after read		0.5tc-14		ns
$t_{d(RDH-D)}$	Next write cycle data output delay time after read <b>(Note 2)</b>		tc-15		ns
$t_w(BXWL)$	Write output pulse width		WL X tc-15		ns
$t_w(BXWH)$	Write output high-level width <b>(Note 1)</b>		WH X tc-15		ns
$t_{d(BXWH-RDH)}$	Read disable valid time after write <b>(Note 2)</b>		tc-15		ns
$t_{d(A-BXWH)}$	Address valid time before write (when the address output select bit = 0)		WH X tc-30		ns
$t_{d(A-BXWH)}$	Address valid time before write (when the address output select bit = 1)		(WH-0.5)tc-19		ns
$t_{h(BXWH-A)}$	Address hold time after write (when the address output select bit = 0) <b>(Note 2)</b>		8		ns
$t_{h(BXWH-A)}$	Address hold time after write (when the address output select bit = 1) <b>(Note 2)</b>		0.5tc-10		ns
$t_{d(BXWH-ALEL)}$	ALE completion delay time after write start			20	ns
$t_{d(ALEL-BXWH)}$	Write disable valid time after ALE completion	Bus cycle = $2\phi + 2\phi$	0.5tc-19		ns
		Bus cycle = $2\phi + 3\phi$ , $2\phi + 4\phi$ , $3\phi + 3\phi$ , $3\phi + 4\phi$	tc-15		ns
$t_{d(CSiL-BXWH)}$	Chip select valid time before write		(WH-0.5)tc-19		ns
$t_{d(CSiL-BXWL)}$	Chip select output valid time before write completion		(WH + WL-0.5)tc-20		ns
$t_{h(BXWH-CSiL)}$	Chip select hold time after write		0.5tc-14		ns
$t_{d(D-BXWL)}$	Data output valid time before write completion		WL X tc-20		ns
$t_{h(BXWH-D)}$	Data hold time after write <b>(Note 3)</b>		0.5tc-10		ns
$t_{pxz(BXWH-DZ)}$	Floating start delay time after write <b>(Note 3)</b>			0.5tc + 10	ns

**Notes 1:** When the bus cycle just before this parameter is for the area where the recovery cycle insertion is selected, this parameter is extended by tc (ns: one recovery cycle is inserted,) or by 2tc (ns: two recovery cycles are inserted.).

**2:** When accessing the area where the recovery cycle insertion is selected, this parameter is extended by tc (ns: one recovery cycle is inserted,) or by 2tc (ns: two recovery cycles are inserted.).

**3:** This parameter is extended by tc (ns) when both of the following conditions are satisfied:

- When accessing the area where the recovery cycle insertion is selected.
- When two recovery cycles are inserted.

MITSUBISHI MICROCOMPUTERS

# M37902FCCHP, M37902FGCHP, M37902FJCHP

SINGLE-CHIP 16-BIT CMOS MICROCOMPUTER

**Switching characteristics** ( $V_{CC} = 5 V \pm 0.5 V$ ,  $V_{SS} = 0 V$ ,  $T_a = -20$  to  $85\text{ }^\circ\text{C}$ ,  $f(\text{fsys}) = 26\text{ MHz}$ , unless otherwise noted)

Symbol	Parameter		Limits		Unit
			Min.	Max.	
$t_d(\text{LA-RDH})$	Address valid time before read		$(\text{WH}-0.5)t_c-19$ <b>(Note)</b>		ns
$t_d(\text{LA-ALEL})$	ALE completion delay time after address stabilization	Bus cycle = $2\phi + 2\phi$	$t_c-20$ <b>(Note)</b>		ns
		Bus cycle = $3\phi + 3\phi$ , $3\phi + 4\phi$	$1.5t_c-20$ <b>(Note)</b>		ns
$t_h(\text{ALEL-LA})$	Address hold time after ALE completion	Bus cycle = $2\phi + 2\phi$	$0.5t_c-19$		ns
		Bus cycle = $3\phi + 3\phi$ , $3\phi + 4\phi$	$t_c-15$		ns
$t_{pxz}(\text{RDH-LAZ})$	Floating start delay time			5	ns
$t_d(\text{LA-BXWH})$	Address valid time before write		$(\text{WH}-0.5)t_c-19$ <b>(Note)</b>		ns
$t_{pzx}(\text{RDH-DZ})$	Floating release delay time		$0.5t_c-19$ <b>(Note)</b>		ns

**Note:** This is independent of the address output select bit's contents.

MITSUBISHI MICROCOMPUTERS

# M37902FCCHP, M37902FGCHP, M37902FJCHP

SINGLE-CHIP 16-BIT CMOS MICROCOMPUTER

Normal access: bus cycle =  $1\phi + 1\phi$ ,  $1\phi + 2\phi$ ,  $1\phi + 3\phi$ ,  
 $2\phi + 3\phi$ , or  $2\phi + 4\phi$

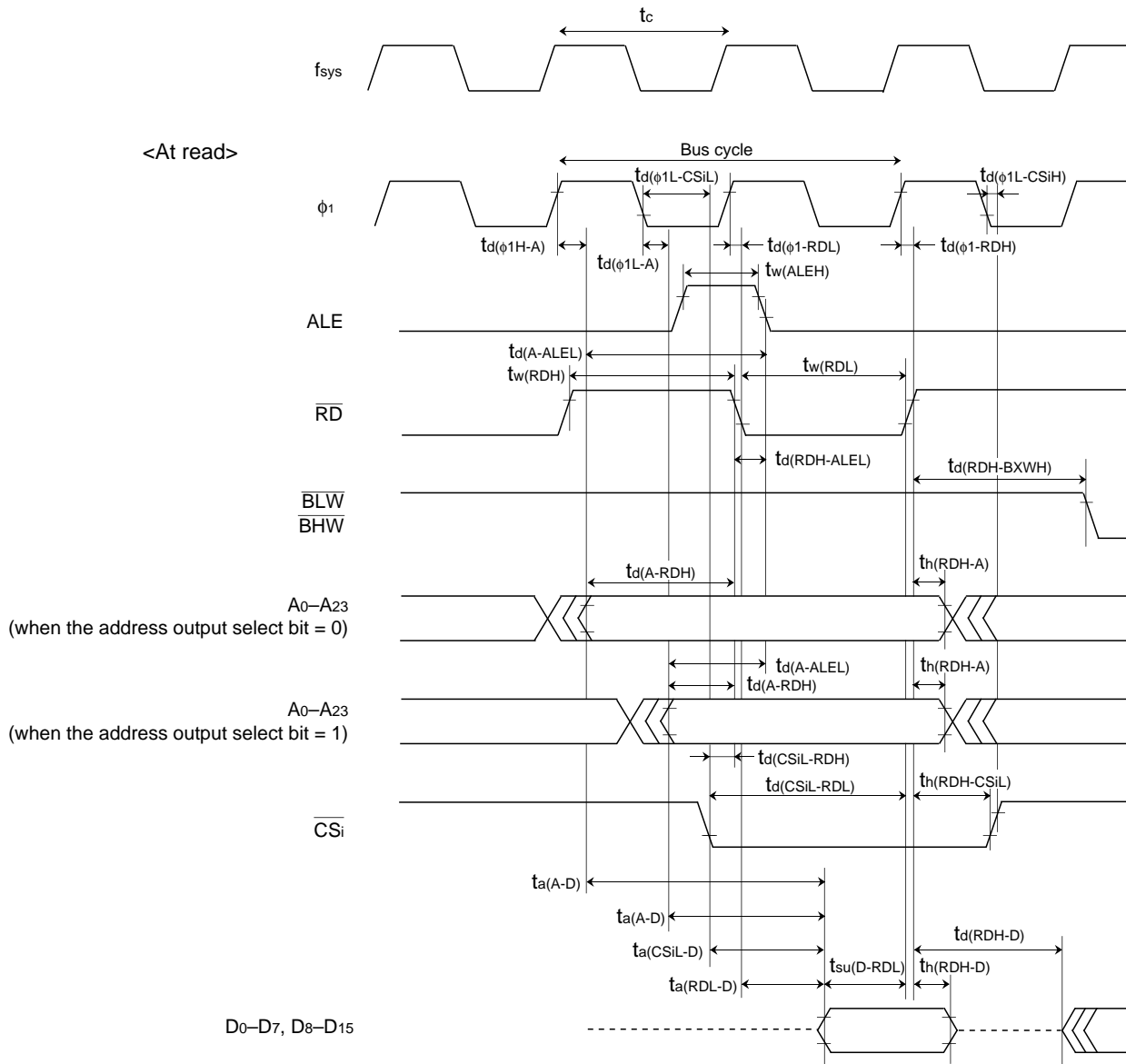

**Test conditions**

- $V_{CC} = 5\text{ V} \pm 0.5\text{ V}$ ,  $T_a = -20\text{ to }85\text{ }^\circ\text{C}$
- Input timing voltage :  $V_{IL}=0.8\text{ V}$ ,  $V_{IH}=2.15\text{ V}$
- Output timing voltage:  $V_{OL}=0.8\text{ V}$ ,  $V_{OH}=2.0\text{ V}$ ,  $C_L=15\text{ pF}$  ( $\overline{CS}_i$ )
- Output timing voltage:  $V_{OL}=0.8\text{ V}$ ,  $V_{OH}=2.0\text{ V}$ ,  $C_L=50\text{ pF}$  (except for  $\overline{CS}_i$ )

MITSUBISHI MICROCOMPUTERS

# M37902FCCHP, M37902FGCHP, M37902FJCHP

SINGLE-CHIP 16-BIT CMOS MICROCOMPUTER

Normal access: bus cycle =  $1\phi + 1\phi, 1\phi + 2\phi, 1\phi + 3\phi,$   
 $2\phi + 3\phi,$  or  $2\phi + 4\phi$

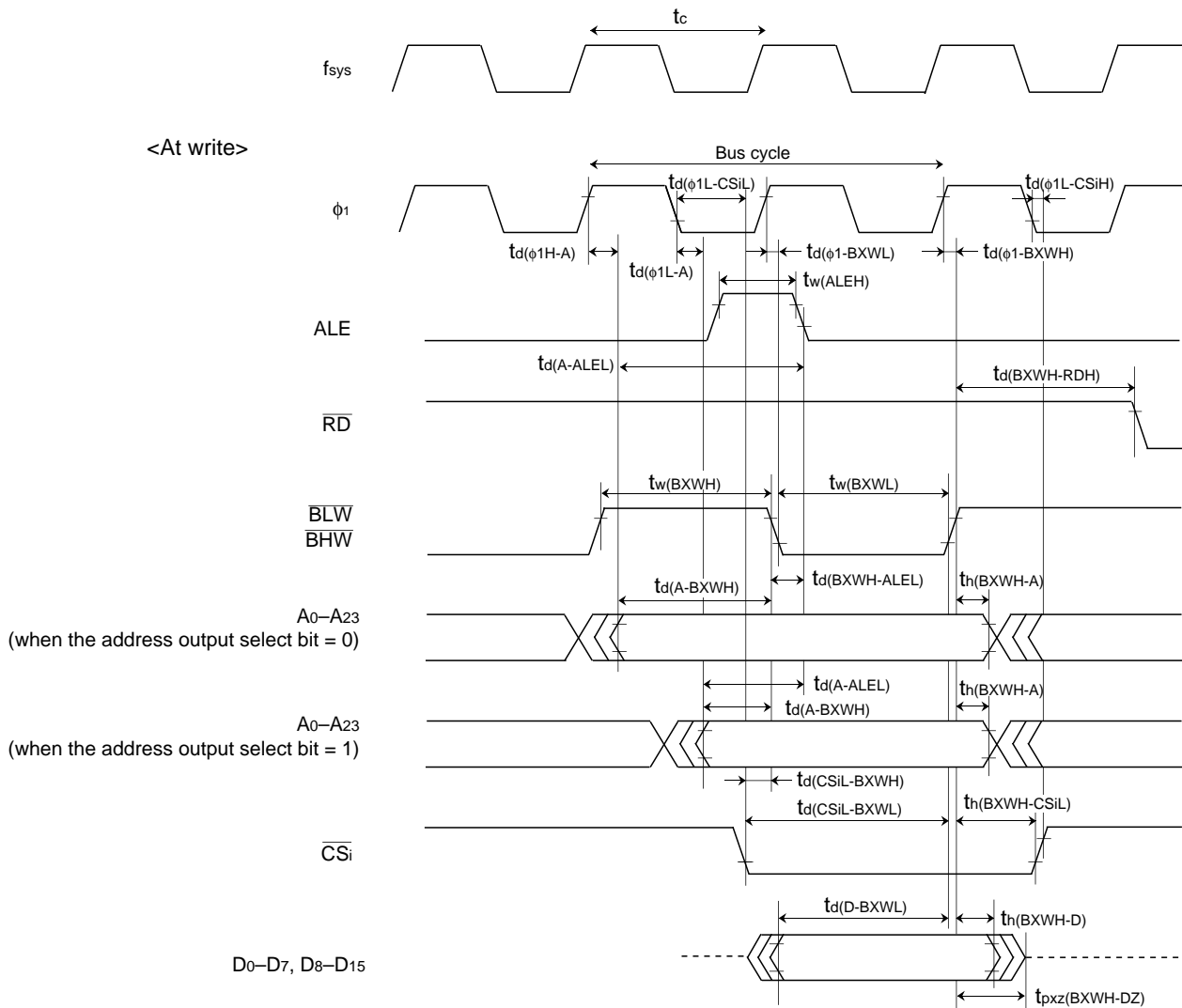

**Test conditions**

- $V_{CC} = 5\text{ V} \pm 0.5\text{ V}$ ,  $T_a = -20\text{ to }85\text{ }^\circ\text{C}$
- Input timing voltage :  $V_{IL}=0.8\text{ V}$ ,  $V_{IH}=2.15\text{ V}$
- Output timing voltage:  $V_{OL}=0.8\text{ V}$ ,  $V_{OH}=2.0\text{ V}$ ,  $C_L=15\text{ pF}$  ( $\overline{CS}_i$ )
- Output timing voltage:  $V_{OL}=0.8\text{ V}$ ,  $V_{OH}=2.0\text{ V}$ ,  $C_L=50\text{ pF}$  (except for  $\overline{CS}_i$ )

MITSUBISHI MICROCOMPUTERS

# M37902FCCHP, M37902FGCHP, M37902FJCHP

SINGLE-CHIP 16-BIT CMOS MICROCOMPUTER

Normal access: bus cycle =  $2\phi + 2\phi, 3\phi + 3\phi, 3\phi + 4\phi$

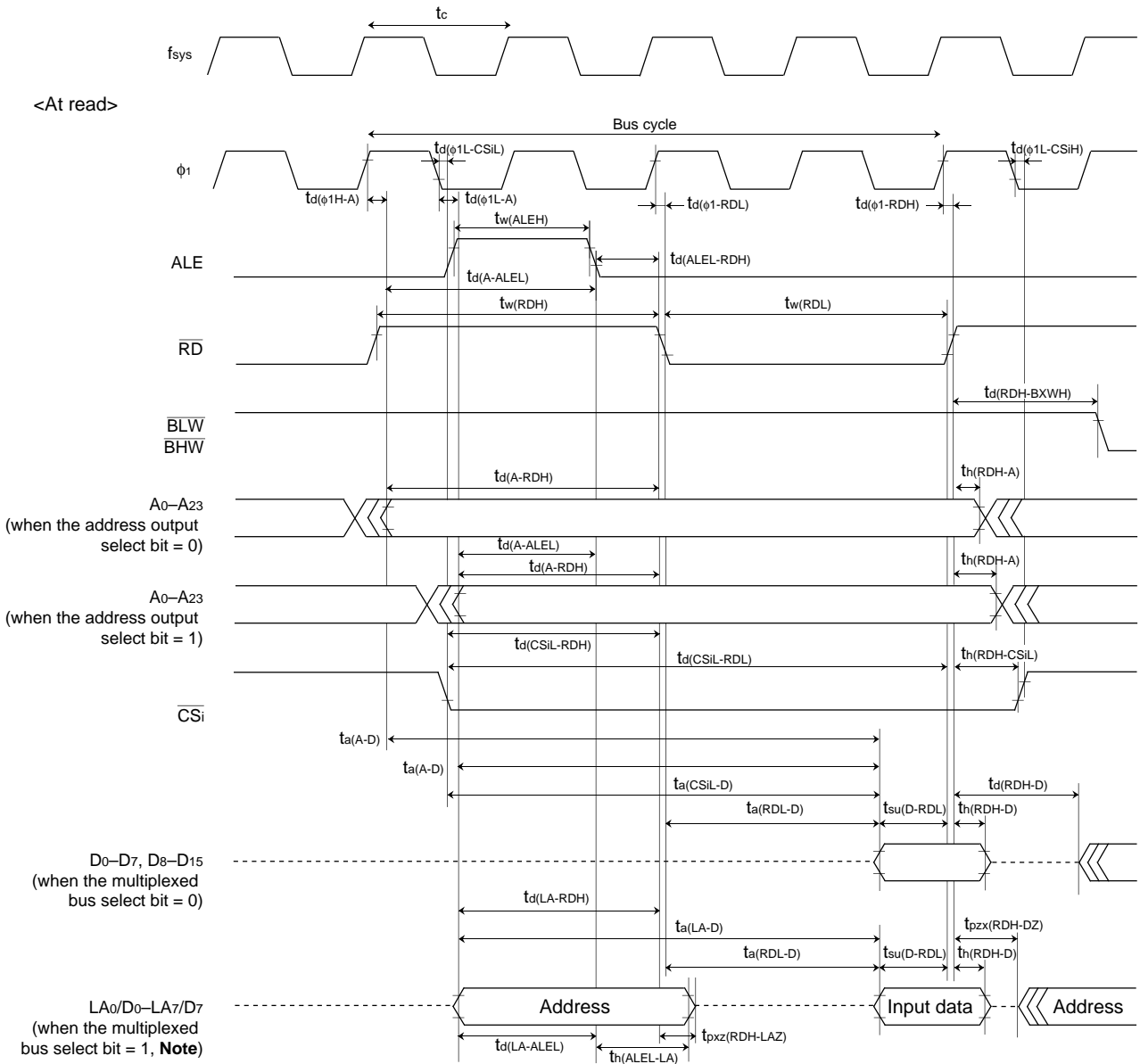

**Note:** Valid only when area  $\overline{CS}_2$  is accessed with the external data bus width = 8 bits.

**Test conditions**

- $V_{CC} = 5\text{ V} \pm 0.5\text{ V}$ ,  $T_a = -20\text{ to }85\text{ }^\circ\text{C}$
- Input timing voltage :  $V_{IL}=0.8\text{ V}$ ,  $V_{IH}=2.15\text{ V}$
- Output timing voltage:  $V_{OL}=0.8\text{ V}$ ,  $V_{OH}=2.0\text{ V}$ ,  $C_L=15\text{ pF}$  ( $\overline{CS}_i$ )
- Output timing voltage:  $V_{OL}=0.8\text{ V}$ ,  $V_{OH}=2.0\text{ V}$ ,  $C_L=50\text{ pF}$  (except for  $\overline{CS}_i$ )



MITSUBISHI MICROCOMPUTERS

# M37902FCCHP, M37902FGCHP, M37902FJCHP

SINGLE-CHIP 16-BIT CMOS MICROCOMPUTER

Normal access: bus cycle =  $2\phi + 2\phi, 3\phi + 3\phi, 3\phi + 4\phi$

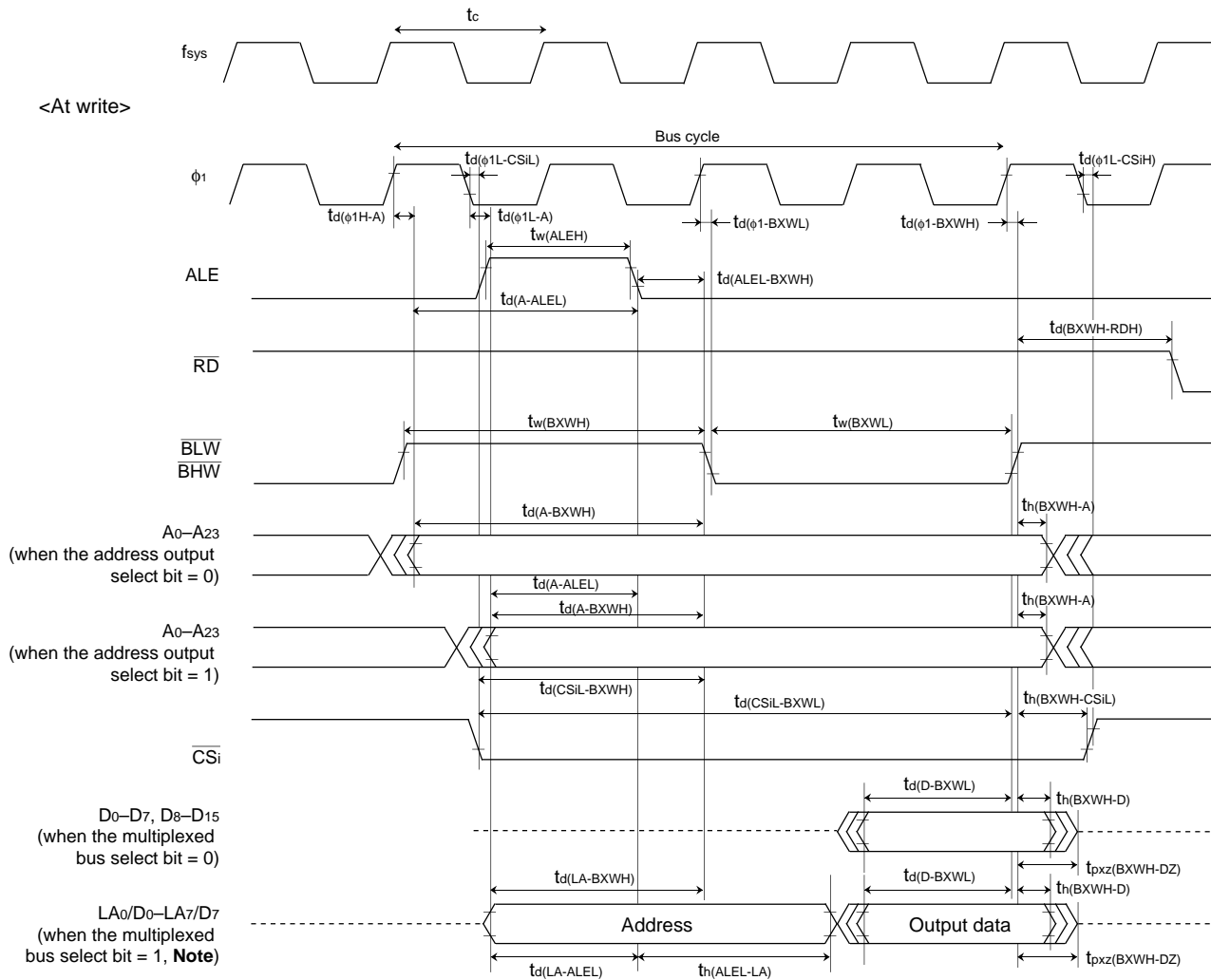

**Note:** Valid only when area  $\overline{CS2}$  is accessed with the external data bus width = 8 bits.

**Test conditions**

- $V_{CC} = 5\text{ V} \pm 0.5\text{ V}$ ,  $T_a = -20\text{ to }85\text{ }^\circ\text{C}$
- Input timing voltage :  $V_{IL}=0.8\text{ V}$ ,  $V_{IH}=2.15\text{ V}$
- Output timing voltage:  $V_{OL}=0.8\text{ V}$ ,  $V_{OH}=2.0\text{ V}$ ,  $C_L=15\text{ pF}$  ( $\overline{CSi}$ )
- Output timing voltage:  $V_{OL}=0.8\text{ V}$ ,  $V_{OH}=2.0\text{ V}$ ,  $C_L=50\text{ pF}$  (except for  $\overline{CSi}$ )

MITSUBISHI MICROCOMPUTERS  
**M37902FCCHP, M37902FGCHP, M37902FJCHP**

SINGLE-CHIP 16-BIT CMOS MICROCOMPUTER

Burst ROM access: bus cycle =  $1\phi + 1\phi + 1\phi + 2\phi + 1\phi + 3\phi + 2\phi + 3\phi + 2\phi + 4\phi$

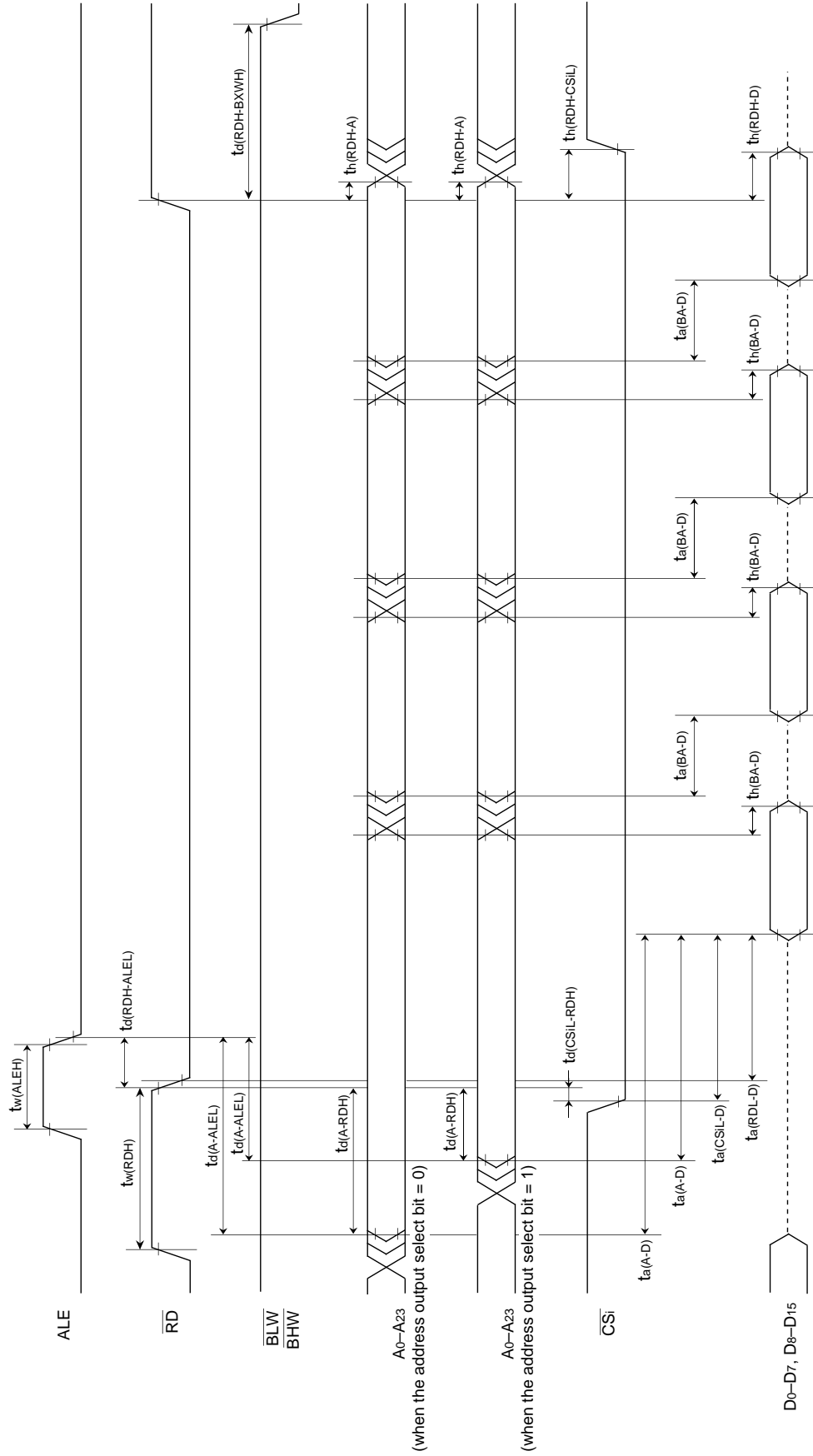

Test conditions

- $V_{cc} = 5 \text{ V} \pm 0.5 \text{ V}$ ,  $T_a = -20 \text{ to } 85 \text{ }^\circ\text{C}$
- Input timing voltage :  $V_{iL}=0.8 \text{ V}$ ,  $V_{iH}=2.15 \text{ V}$
- Output timing voltage:  $V_{oL}=0.8 \text{ V}$ ,  $V_{oH}=2.0 \text{ V}$ ,  $C_L=15 \text{ pF}$  (CSi)
- Output timing voltage:  $V_{oL}=0.8 \text{ V}$ ,  $V_{oH}=2.0 \text{ V}$ ,  $C_L=50 \text{ pF}$  (except for CSi)

# MITSUBISHI MICROCOMPUTERS

## M37902FCCHP, M37902FGCHP, M37902FJCHP

SINGLE-CHIP 16-BIT CMOS MICROCOMPUTER

### PACKAGE OUTLINE

#### 100P6Q-A

Plastic 100pin 14X14mm body LQFP

EIAJ Package Code	JEDEC Code	Weight(g)	Lead Material
LQFP100-P-1414-0.50	-		Cu Alloy

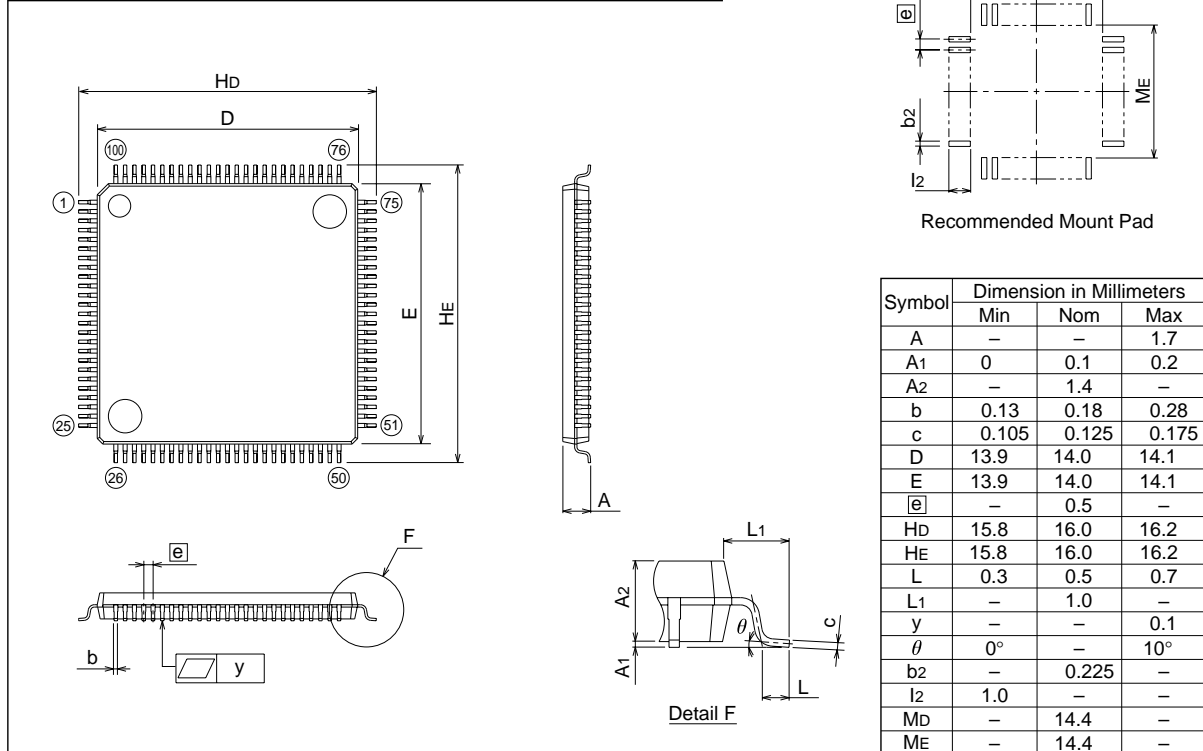

#### Keep safety first in your circuit designs!

- Mitsubishi Electric Corporation puts the maximum effort into making semiconductor products better and more reliable, but there is always the possibility that trouble may occur with them. Trouble with semiconductors may lead to personal injury, fire or property damage. Remember to give due consideration to safety when making your circuit designs, with appropriate measures such as (i) placement of substitutive, auxiliary circuits, (ii) use of non-flammable material or (iii) prevention against any malfunction or mishap.

#### Notes regarding these materials

- These materials are intended as a reference to assist our customers in the selection of the Mitsubishi semiconductor product best suited to the customer's application; they do not convey any license under any intellectual property rights, or any other rights, belonging to Mitsubishi Electric Corporation or a third party.
- Mitsubishi Electric Corporation assumes no responsibility for any damage, or infringement of any third-party's rights, originating in the use of any product data, diagrams, charts, programs, algorithms, or circuit application examples contained in these materials.
- All information contained in these materials, including product data, diagrams, charts, programs and algorithms represents information on products at the time of publication of these materials, and are subject to change by Mitsubishi Electric Corporation without notice due to product improvements or other reasons. It is therefore recommended that customers contact Mitsubishi Electric Corporation or an authorized Mitsubishi Semiconductor product distributor for the latest product information before purchasing a product listed herein. The information described here may contain technical inaccuracies or typographical errors. Mitsubishi Electric Corporation assumes no responsibility for any damage, liability, or other loss rising from these inaccuracies or errors. Please also pay attention to information published by Mitsubishi Electric Corporation by various means, including the Mitsubishi Semiconductor home page (<http://www.mitsubishichips.com>).
- When using any or all of the information contained in these materials, including product data, diagrams, charts, programs, and algorithms, please be sure to evaluate all information as a total system before making a final decision on the applicability of the information and products. Mitsubishi Electric Corporation assumes no responsibility for any damage, liability or other loss resulting from the information contained herein.
- Mitsubishi Electric Corporation semiconductors are not designed or manufactured for use in a device or system that is used under circumstances in which human life is potentially at stake. Please contact Mitsubishi Electric Corporation or an authorized Mitsubishi Semiconductor product distributor when considering the use of a product contained herein for any specific purposes, such as apparatus or systems for transportation, vehicular, medical, aerospace, nuclear, or undersea repeater use.
- The prior written approval of Mitsubishi Electric Corporation is necessary to reprint or reproduce in whole or in part these materials.
- If these products or technologies are subject to the Japanese export control restrictions, they must be exported under a license from the Japanese government and cannot be imported into a country other than the approved destination. Any diversion or reexport contrary to the export control laws and regulations of Japan and/or the country of destination is prohibited.
- Please contact Mitsubishi Electric Corporation or an authorized Mitsubishi Semiconductor product distributor for further details on these materials or the products contained therein.

## Revision History

## M37902FxCHP Datasheet

Rev. No.	Revision Description	Rev. date						
1.0	First Edition	990305						
2.0	Refer to <b>Corrections and Supplementary Explanation for “M37902FxC Datasheet (REV.A)”</b> .	990625						
3.0	<p>The following are revised/added points in this edition:</p> <ul style="list-style-type: none"> <li>Figure 26 in page 40; the bit's name (bit 7) of the port function control register            &lt;Error&gt; Pin <math>\overline{\text{NMI}}</math> pullup <u>connection</u> select bit (<b>Note 2</b>)            &lt;Correction&gt; Pin <math>\overline{\text{NMI}}</math> pullup select bit (<b>Note 2</b>)</li> <li>Page 95; <b>CLOCK GENERATING CIRCUIT</b>, Right column, line 10            &lt;Error&gt; •••• the PLL output clock (f<sub>PLL</sub>). (In other words, set bit 5 to “1”.)            &lt;Correction&gt; •••• the PLL output clock (f<sub>PLL</sub>). (In other words, set bit 5 to “1”.) <u>Note that, after reset, the PLL multiplication ratio select bits are allowed to be changed only once.</u></li> <li>Table 15 in page 95; Note is revised.            &lt;Error&gt; •••• f(X<sub>IN</sub>) means the frequency of the input clock from pin X<sub>IN</sub> f(X<sub>IN</sub>).            &lt;Correction&gt; •••• f(X<sub>IN</sub>) means the frequency of the input clock from pin X<sub>IN</sub> f(X<sub>IN</sub>). <u>After reset, the PLL multiplication ratio select bits are allowed to be changed only once.</u></li> <li>Page 120; <b>RECOMMENDED OPERATING CONDITIONS</b>            &lt;Error&gt;  <table border="1" data-bbox="245 1319 1115 1361"> <tr> <td>f(f<sub>sys</sub>)</td> <td>External clock input frequency (<b>Note 2</b>)</td> <td>••••••••</td> </tr> </table>           &lt;Correction&gt;  <table border="1" data-bbox="245 1400 1115 1442"> <tr> <td>f(X<sub>IN</sub>)</td> <td>External clock input frequency (<b>Note 2</b>)</td> <td>••••••••</td> </tr> </table> </li> </ul>	f(f <sub>sys</sub> )	External clock input frequency ( <b>Note 2</b> )	••••••••	f(X <sub>IN</sub> )	External clock input frequency ( <b>Note 2</b> )	••••••••	990917
f(f <sub>sys</sub> )	External clock input frequency ( <b>Note 2</b> )	••••••••						
f(X <sub>IN</sub> )	External clock input frequency ( <b>Note 2</b> )	••••••••						
4.0	<p>The following are revised/added points in this edition:</p> <ul style="list-style-type: none"> <li>Page 83; <b>D-A CONVERTER</b>, Left column, line 15            &lt;Error&gt; <u>The D-A output enable bit is</u> cleared to “0” at reset. ••••            &lt;Correction&gt; <u>The contents of the corresponding D-A output enable bit and D-A register are</u> cleared to “0” at reset. ••••</li> <li>Page 83; <b>D-A CONVERTER</b>, Right column, line 1            &lt;Error&gt; with pin D-Ai.            &lt;Correction&gt; with pin D-Ai. <u>Also, when not using the D-A converter, be sure to clear the contents of the corresponding D-A output enable bit and D-A register to “0”.</u></li> </ul>	991008						
5.0	<p>Refer to <b>Corrections and Supplementary Explanation for “M37902FxC Datasheet (REV.B)”</b>.</p> <p><b>Notes 1:</b> ★ represents the new information added in Rev.5.0.</p> <p><b>2:</b> The revised/added points informed in Rev.3.0 and Rev.4.0 are included in <b>Corrections and Supplementary Explanation for “M37902FxC Datasheet (REV.B)”</b>.</p>	000629						

# Corrections and Supplementary Explanation for M37902FxC Datasheet (REV.B) NO.1

Page	Error	Correction																																	
★ All pages, Header	PRELIMINARY Notice: This is not a final specification. Some parametric limits are subject to change.	(Deleted)																																	
	<u>M37902F8CGP, M37902F8CHP, M37902FCCGP, M37902FCCHP, M37902FECGP, M37902FECHP, M37902FGCGP, M37902FGCHP, M37902FHCGP, M37902FHCHP, M37902FJCGP, M37902FJCHP</u>	M37902FCCHP, M37902FGCHP, M37902FJCHP																																	
★ Page 1, DISTINCTIVE FEATURES ; Memory	[M37902F8CGP, M37902F8CHP] Flash memory (User ROM area) .....60 Kbytes RAM.....2048 bytes	(Deleted)																																	
	[M37902FCCGP, M37902FCCHP] Flash memory (User ROM area) .....120 Kbytes RAM.....4096 bytes	[M37902FCCHP] Flash memory (User ROM area) .....120 Kbytes RAM.....4096 bytes																																	
	[M37902FECGP, M37902FECHP] Flash memory (User ROM area) .....184 Kbytes RAM.....6144 bytes	(Deleted)																																	
	[M37902FGCGP, M37902FGCHP] Flash memory (User ROM area) .....248 Kbytes RAM.....6144 bytes	[M37902FGCHP] Flash memory (User ROM area) .....248 Kbytes RAM.....6144 bytes																																	
	[M37902FHCGP, M37902FHCHP] Flash memory (User ROM area) .....370 Kbytes RAM.....12288 bytes	(Deleted)																																	
	[M37902FJCGP, M37902FJCHP] Flash memory (User ROM area) .....498 Kbytes RAM.....12288 bytes	[M37902FJCHP] Flash memory (User ROM area) .....498 Kbytes RAM.....12288 bytes																																	
★ Page 1, APPLICATION	Control devices for personal computer peripheral equipment such as CD-ROM drives, DVD-ROM drives, hard disk drives, high density FDD, printers Control devices for office equipment such as copiers and facsimiles Control devices for industrial equipment such as communication and measuring instruments	Control devices for personal computer peripheral equipment such as CD-ROM drives, DVD-ROM drives, hard disk drives, high density FDD, printers																																	
★ ———	M37902FxCGP PIN CONFIGURATION (TOP VIEW)	(Deleted)																																	
★ Page 2, PIN CONFIGURATION Page 105, Fig. 112, Pin connection of M37902FxC in flash memory	<u>P6<sub>3</sub>/INT<sub>2</sub></u>  (Type) M37902F8CHP M37902FCCHP M37902FECHP M37902FGCHP M37902FHCHP M37902FJCHP	<u>P6<sub>4</sub>/INT<sub>2</sub></u>  (Type) M37902FCCHP M37902FGCHP M37902FJCHP																																	
★ Page 3, BLOCK DIAGRAM, <b>Note:</b>	<b>Note:</b> <table border="1"> <thead> <tr> <th></th> <th>Flash memory</th> <th>RAM</th> </tr> </thead> <tbody> <tr> <td><u>M37902F8CGP, M37902F8CHP</u></td> <td>60 Kbytes</td> <td>2048 bytes</td> </tr> <tr> <td><u>M37902FCCGP, M37902FCCHP</u></td> <td>120 Kbytes</td> <td>4096 bytes</td> </tr> <tr> <td><u>M37902FECGP, M37902FECHP</u></td> <td>184 Kbytes</td> <td>6144 bytes</td> </tr> <tr> <td><u>M37902FGCGP, M37902FGCHP</u></td> <td>248 Kbytes</td> <td>6144 bytes</td> </tr> <tr> <td><u>M37902FHCGP, M37902FHCHP</u></td> <td>370 Kbytes</td> <td>12288 bytes</td> </tr> <tr> <td><u>M37902FJCGP, M37902FJCHP</u></td> <td>498 Kbytes</td> <td>12288 bytes</td> </tr> </tbody> </table>		Flash memory	RAM	<u>M37902F8CGP, M37902F8CHP</u>	60 Kbytes	2048 bytes	<u>M37902FCCGP, M37902FCCHP</u>	120 Kbytes	4096 bytes	<u>M37902FECGP, M37902FECHP</u>	184 Kbytes	6144 bytes	<u>M37902FGCGP, M37902FGCHP</u>	248 Kbytes	6144 bytes	<u>M37902FHCGP, M37902FHCHP</u>	370 Kbytes	12288 bytes	<u>M37902FJCGP, M37902FJCHP</u>	498 Kbytes	12288 bytes	<b>Note:</b> <table border="1"> <thead> <tr> <th></th> <th>Flash memory</th> <th>RAM</th> </tr> </thead> <tbody> <tr> <td><u>M37902FCCHP</u></td> <td>120 Kbytes</td> <td>4096 bytes</td> </tr> <tr> <td><u>M37902FGCHP</u></td> <td>248 Kbytes</td> <td>6144 bytes</td> </tr> <tr> <td><u>M37902FJCHP</u></td> <td>498 Kbytes</td> <td>12288 bytes</td> </tr> </tbody> </table>		Flash memory	RAM	<u>M37902FCCHP</u>	120 Kbytes	4096 bytes	<u>M37902FGCHP</u>	248 Kbytes	6144 bytes	<u>M37902FJCHP</u>	498 Kbytes	12288 bytes
	Flash memory	RAM																																	
<u>M37902F8CGP, M37902F8CHP</u>	60 Kbytes	2048 bytes																																	
<u>M37902FCCGP, M37902FCCHP</u>	120 Kbytes	4096 bytes																																	
<u>M37902FECGP, M37902FECHP</u>	184 Kbytes	6144 bytes																																	
<u>M37902FGCGP, M37902FGCHP</u>	248 Kbytes	6144 bytes																																	
<u>M37902FHCGP, M37902FHCHP</u>	370 Kbytes	12288 bytes																																	
<u>M37902FJCGP, M37902FJCHP</u>	498 Kbytes	12288 bytes																																	
	Flash memory	RAM																																	
<u>M37902FCCHP</u>	120 Kbytes	4096 bytes																																	
<u>M37902FGCHP</u>	248 Kbytes	6144 bytes																																	
<u>M37902FJCHP</u>	498 Kbytes	12288 bytes																																	
Page 4, Chip-select wait control	Chip select area X 4 ( <u>CS<sub>0</sub>-CS<sub>3</sub></u> ). A wait number and bus width can be set for each chip select area.	Chip select area X 4 ( <u>CS<sub>0</sub>-CS<sub>3</sub></u> ). A bus cycle type and bus width can be set for each chip select area.																																	

# Corrections and Supplementary Explanation for M37902FxC Datasheet (REV.B) NO.2

Page	Error	Correction																																								
★ Page 4, Parameter	Operating temperature range	Operating ambient temperature range																																								
★ Page 4, Note:	<p><b>Note:</b></p> <table border="1"> <tr> <td rowspan="5">Flash memory (User ROM area)</td> <td>M37902F8CGP, M37902F8CHP</td> <td>60 Kbytes</td> </tr> <tr> <td>M37902FCCGP, M37902FCCHP</td> <td>120 Kbytes</td> </tr> <tr> <td>M37902FECGP, M37902FECHP</td> <td>184 Kbytes</td> </tr> <tr> <td>M37902FGCGP, M37902FGCHP</td> <td>248 Kbytes</td> </tr> <tr> <td>M37902FHCGP, M37902FHCHP</td> <td>370 Kbytes</td> </tr> <tr> <td rowspan="5">RAM</td> <td>M37902FJCGP, M37902FJCHP</td> <td>498 Kbytes</td> </tr> <tr> <td>M37902F8CGP, M37902F8CHP</td> <td>2048 bytes</td> </tr> <tr> <td>M37902FCCGP, M37902FCCHP</td> <td>4096 bytes</td> </tr> <tr> <td>M37902FECGP, M37902FECHP</td> <td>6144 bytes</td> </tr> <tr> <td>M37902FGCGP, M37902FGCHP</td> <td>6144 bytes</td> </tr> <tr> <td>M37902FHCGP, M37902FHCHP</td> <td>12288 bytes</td> </tr> <tr> <td>M37902FJCGP, M37902FJCHP</td> <td>12288 bytes</td> </tr> </table>	Flash memory (User ROM area)	M37902F8CGP, M37902F8CHP	60 Kbytes	M37902FCCGP, M37902FCCHP	120 Kbytes	M37902FECGP, M37902FECHP	184 Kbytes	M37902FGCGP, M37902FGCHP	248 Kbytes	M37902FHCGP, M37902FHCHP	370 Kbytes	RAM	M37902FJCGP, M37902FJCHP	498 Kbytes	M37902F8CGP, M37902F8CHP	2048 bytes	M37902FCCGP, M37902FCCHP	4096 bytes	M37902FECGP, M37902FECHP	6144 bytes	M37902FGCGP, M37902FGCHP	6144 bytes	M37902FHCGP, M37902FHCHP	12288 bytes	M37902FJCGP, M37902FJCHP	12288 bytes	<p><b>Note:</b></p> <table border="1"> <tr> <td rowspan="3">Flash memory (User ROM area)</td> <td>M37902FCCHP</td> <td>120 Kbytes</td> </tr> <tr> <td>M37902FGCHP</td> <td>248 Kbytes</td> </tr> <tr> <td>M37902FJCHP</td> <td>498 Kbytes</td> </tr> <tr> <td rowspan="3">RAM</td> <td>M37902FCCHP</td> <td>4096 bytes</td> </tr> <tr> <td>M37902FGCHP</td> <td>6144 bytes</td> </tr> <tr> <td>M37902FJCHP</td> <td>12288 bytes</td> </tr> </table>	Flash memory (User ROM area)	M37902FCCHP	120 Kbytes	M37902FGCHP	248 Kbytes	M37902FJCHP	498 Kbytes	RAM	M37902FCCHP	4096 bytes	M37902FGCHP	6144 bytes	M37902FJCHP	12288 bytes
Flash memory (User ROM area)	M37902F8CGP, M37902F8CHP		60 Kbytes																																							
	M37902FCCGP, M37902FCCHP		120 Kbytes																																							
	M37902FECGP, M37902FECHP		184 Kbytes																																							
	M37902FGCGP, M37902FGCHP		248 Kbytes																																							
	M37902FHCGP, M37902FHCHP	370 Kbytes																																								
RAM	M37902FJCGP, M37902FJCHP	498 Kbytes																																								
	M37902F8CGP, M37902F8CHP	2048 bytes																																								
	M37902FCCGP, M37902FCCHP	4096 bytes																																								
	M37902FECGP, M37902FECHP	6144 bytes																																								
	M37902FGCGP, M37902FGCHP	6144 bytes																																								
M37902FHCGP, M37902FHCHP	12288 bytes																																									
M37902FJCGP, M37902FJCHP	12288 bytes																																									
Flash memory (User ROM area)	M37902FCCHP	120 Kbytes																																								
	M37902FGCHP	248 Kbytes																																								
	M37902FJCHP	498 Kbytes																																								
RAM	M37902FCCHP	4096 bytes																																								
	M37902FGCHP	6144 bytes																																								
	M37902FJCHP	12288 bytes																																								
★ Page 5, Notes 1:	<table border="1"> <tr> <td rowspan="6">User ROM area</td> <td>M37902F8CGP, M37902F8CHP</td> <td>4 blocks</td> </tr> <tr> <td>M37902FCCGP, M37902FCCHP</td> <td>5 blocks</td> </tr> <tr> <td>M37902FECGP, M37902FECHP</td> <td>6 blocks</td> </tr> <tr> <td>M37902FGCGP, M37902FGCHP</td> <td>7 blocks</td> </tr> <tr> <td>M37902FHCGP, M37902FHCHP</td> <td>9 blocks</td> </tr> <tr> <td>M37902FJCGP, M37902FJCHP</td> <td>11 blocks</td> </tr> </table>	User ROM area	M37902F8CGP, M37902F8CHP	4 blocks	M37902FCCGP, M37902FCCHP	5 blocks	M37902FECGP, M37902FECHP	6 blocks	M37902FGCGP, M37902FGCHP	7 blocks	M37902FHCGP, M37902FHCHP	9 blocks	M37902FJCGP, M37902FJCHP	11 blocks	<table border="1"> <tr> <td rowspan="3">User ROM area</td> <td>M37902FCCHP</td> <td>5 blocks</td> </tr> <tr> <td>M37902FGCHP</td> <td>7 blocks</td> </tr> <tr> <td>M37902FJCHP</td> <td>11 blocks</td> </tr> </table>	User ROM area	M37902FCCHP	5 blocks	M37902FGCHP	7 blocks	M37902FJCHP	11 blocks																				
User ROM area	M37902F8CGP, M37902F8CHP		4 blocks																																							
	M37902FCCGP, M37902FCCHP		5 blocks																																							
	M37902FECGP, M37902FECHP		6 blocks																																							
	M37902FGCGP, M37902FGCHP		7 blocks																																							
	M37902FHCGP, M37902FHCHP		9 blocks																																							
	M37902FJCGP, M37902FJCHP	11 blocks																																								
User ROM area	M37902FCCHP	5 blocks																																								
	M37902FGCHP	7 blocks																																								
	M37902FJCHP	11 blocks																																								
★ Page 6, P4 <sub>0</sub> –P4 <sub>7</sub>	<p>.....</p> <p>■ In microprocessor mode</p> <p>..... According to the register setting, P4<sub>0</sub>–P4<sub>4</sub> also .....</p>	<p>.....</p> <p>■ In microprocessor mode</p> <p>..... According to the register setting, P4<sub>0</sub>–P4<sub>3</sub> also .....</p>																																								
★ Page 9, MEMORY, Line 2	<p>..... The address space is 16 Mbytes from address 0<sub>16</sub> to FFFFFFF<sub>16</sub>. .....</p>	<p>..... The address space is 16 Mbytes from addresses 0<sub>16</sub> to FFFFFFF<sub>16</sub>. .....</p>																																								
★ ———	Memory map of M37902F8CGP and M37902F8CHP (Single-chip mode)	(Deleted)																																								
★ Page 9, Fig. 1	<p>Fig. 2. Memory map of M37902FCCGP and M37902FCCHP (Single-chip mode)</p>	<p>Fig. 1. Memory map of M37902FCCHP (Single-chip mode)</p>																																								
★ ———	Memory map of M37902FECGP and M37902FECHP (Single-chip mode)	(Deleted)																																								
★ ———	Memory map of M37902FHCGP and M37902FHCHP (Single-chip mode)	(Deleted)																																								

# Corrections and Supplementary Explanation for M37902FxC Datasheet (REV.B) NO.3

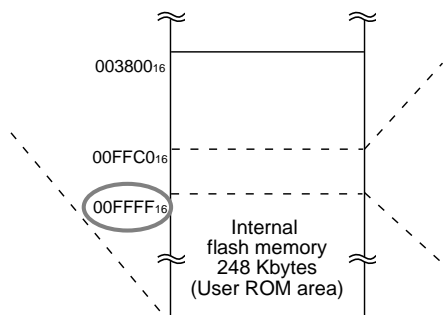
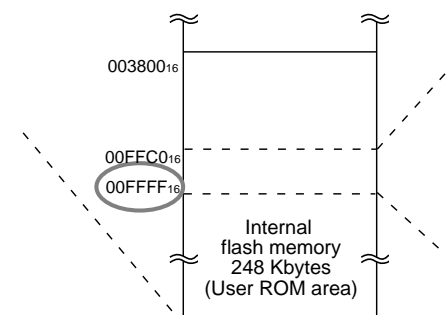
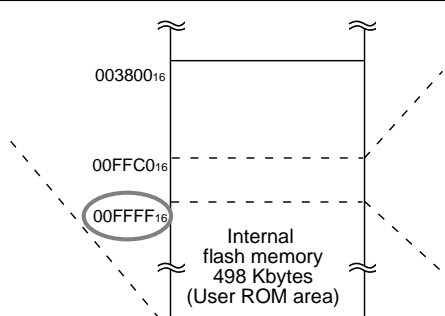
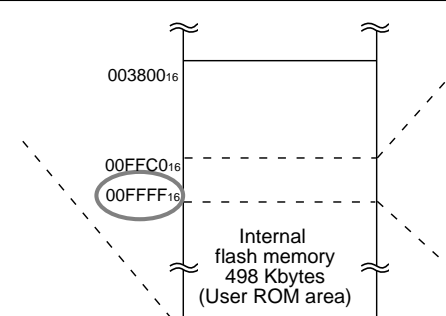
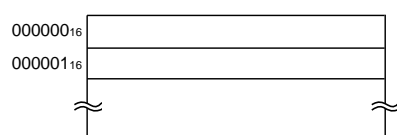
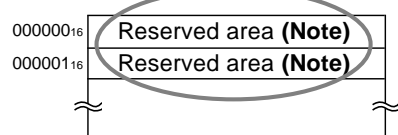
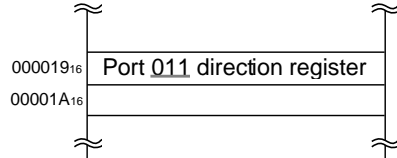
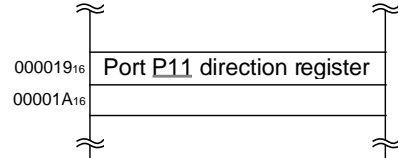
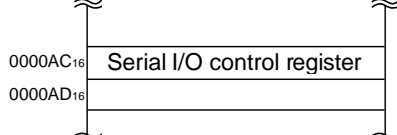
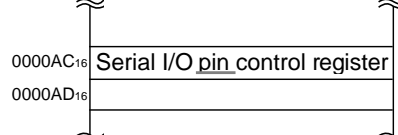
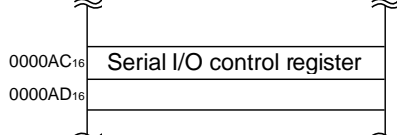
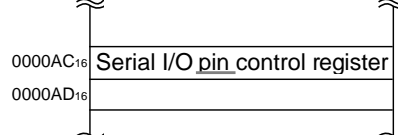
Page	Error	Correction
<p>★ Page 10, Fig. 2</p>	<p>Fig. 4. Memory map of M37902FGCGP and M37902FGCHP (Single-chip mode)</p> 	<p>Fig. 2. Memory map of M37902FGCHP (Single-chip mode)</p> 
<p>★ Page 10, Fig. 3</p>	<p>Fig. 6. Memory map of M37902FJCGP and M37902FJCHP (Single-chip mode)</p> 	<p>Fig. 3. Memory map of M37902FJCHP (Single-chip mode)</p> 
<p>★ Page 11, Fig. 7</p>	<p>address 0016, 0116</p> 	<p>Reserved area (Note) Reserved area (Note)</p> 
<p>address 1916</p>	<p>Port Q11 direction register</p> 	<p>Port P11 direction register</p> 
<p>★ Page 12, Fig. 8</p>	<p>address A616</p> <p>Reserved area (Note)</p> 	<p>(Deleted)</p> 
<p>address AC16, AD16</p>	<p>Serial I/O control register</p> 	<p>Serial I/O pin control register</p> 

# Corrections and Supplementary Explanation for M37902FxC Datasheet (REV.B) NO.4

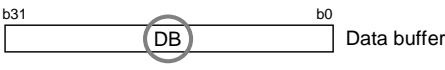
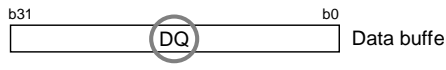
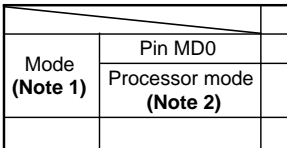
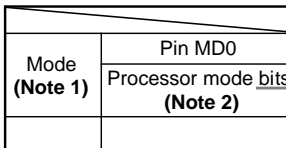
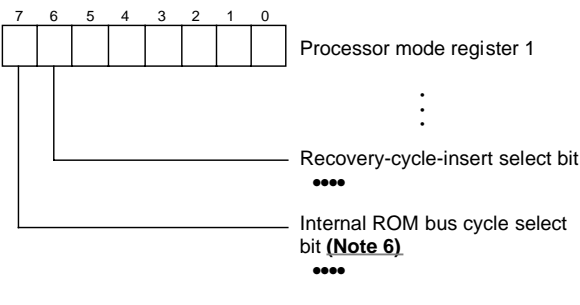
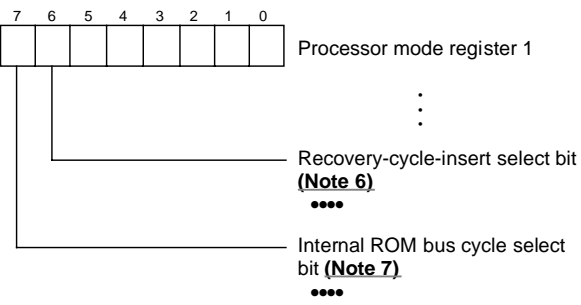
Page	Error	Correction
★ Page 18, Table 1	Temporarily stores an instruction which .....	Temporarily stores an instruction which .....
Instruction queue buffer		
Data buffer	Temporarily stores data which has been ....., and external areas by the BIU or which is to be written to internal memory, .....	Temporarily stores data which has been ....., and external areas by the BIU; or temporarily stores data which is to be written to internal memory, .....
★ Page 18, Fig. 11	 Data buffer	 Data buffer
Page 26, Fig. 18, Notes 1	<b>Notes 1:</b> The number of bus cycles is determined by the following bits: .....	<b>Notes 1:</b> The bus cycle type is determined by the following bits: .....
Page 31, Right column Line 5	..... Therefore, ports P0 or P4, P10, P11 function as I/O pins for the address bus, .....	..... Therefore, ports P0 to P4, P10, P11 function as I/O pins for the address bus, .....
Page 33, Table 5		
★ Page 35, Fig. 24, Note	<b>Notes 1:</b> While Vss ....., bit 1 is cleared to "0". While Vcc ....., bit 1 is set to "1" at reset. (Fixed to "1".)  <b>3:</b> While Vss ....., bit 7 is cleared to "0". While Vcc ....., bit 7 is set to "1" at reset.	<b>Notes 1:</b> While Vss ....., this bit's state is cleared to "0" at reset. While Vcc ....., this bit's state is set to "1" at reset. (Fixed to "1".)  <b>3:</b> While Vss ....., this bit's state is cleared to "0" at reset. While Vcc ....., this bit's state is set to "1" at reset.
★ Page 36, Fig. 25	 Processor mode register 1 ..... Recovery-cycle-insert select bit .....	 Processor mode register 1 ..... Recovery-cycle-insert select bit (Note 6) .....
	<b>2:</b> After reset, this bit can be set only once. During the software execution, be sure not to change this bit.	<b>2:</b> After reset, this bit's contents can be switched only once. During the software execution, be sure not to switch this bit's contents.
	<b>4:</b> While Vss ....., these bits are cleared to "0". While Vcc ....., on the other hand, these bits are set to "1".	<b>4:</b> While Vss ....., each of these bits is "0" at reset. While Vcc ....., on the other hand, each of these bits is "1" at reset.
	<b>5:</b> After reset, these bits can be set to "1" only once. Once these bits have been cleared to "0" from "1", they cannot be set to "1" again. (Fixed to "0".)	<b>5:</b> In the memory expansion or microprocessor mode, if this bit's contents is switched from "1" to "0", this bit will be cleared to "0". After this clearance, this bit cannot return to "1". If it is necessary to set this bit to "1", be sure to reset the microcomputer.



# Corrections and Supplementary Explanation for M37902FxC Datasheet (REV.B) NO.5

Page	Error	Correction
★ Page 36, Fig. 25	_____	<p><b>6:</b> The program which switches this bit's contents must be assigned to the internal area.</p> <p><b>7:</b> In the microprocessor mode, this bit is invalid.</p> <p>(When the internal flash memory is reprogrammed in the CPU reprogramming mode, be sure to clear this bit to "0".)</p>
Page 37, Fig. 26, bit 4		
Page 39, Table 7		
★ Page 40, Fig. 28, CS <sub>0</sub> control register L; Note	<p><b>Notes 1:</b> While V<sub>SS</sub> ....., this bit is cleared to "0". While V<sub>CC</sub> ....., this bit is set to "1" at reset.</p> <p><b>5:</b> While V<sub>SS</sub> ....., this bit is cleared to "0". While V<sub>CC</sub> ....., this bit is set to "1" at reset. (Fixed to "1".)</p>	<p><b>Notes 1:</b> While V<sub>SS</sub> ....., this bit's state is cleared to "0" at reset. While V<sub>CC</sub> ....., this bit's state is set to "1" at reset.</p> <p><b>5:</b> While V<sub>SS</sub> ....., this bit's state is cleared to "0" at reset. While V<sub>CC</sub> ....., this bit's state is set to "1" at reset. (Fixed to "1".)</p>
★ Page 42, Fig. 30, Area CS <sub>x</sub> start address register (x = 0 to 3)		
Page 43, Fig. 31	<p>Start address : 4000<sub>16</sub></p> <p>256 K bytes</p>	<p>Start address : 4000<sub>16</sub></p>

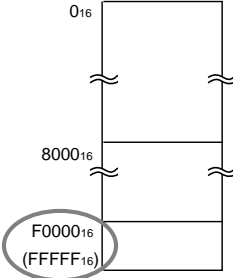
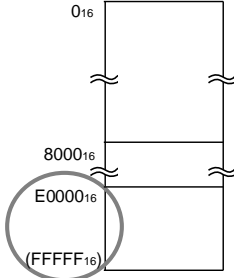
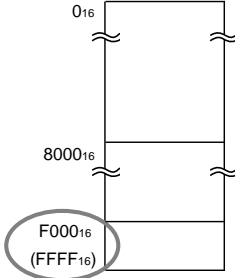
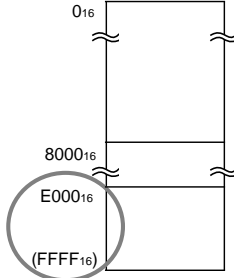
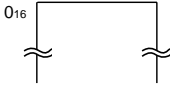
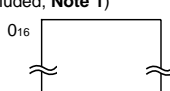
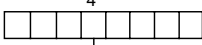
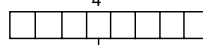
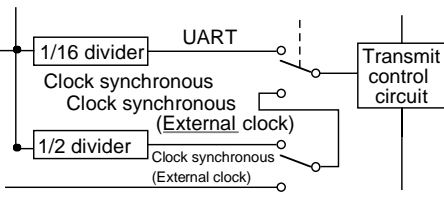
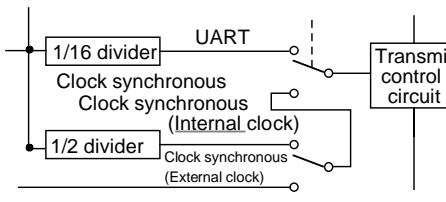

# Corrections and Supplementary Explanation for M37902FxC Datasheet (REV.B) NO.6

Page	Error	Correction
Page 44, Fig. 32	<p>Block size : 4 Kbytes      Block size : 8 Kbytes</p> <p>Addresses which can be ***** (Address FFFF<sub>16</sub> is not included; <b>Note 1</b>)</p>  <p>Addresses which can be ***** (Address FFFF<sub>16</sub> is not included; <b>Note 1</b>)</p> 	<p>Block size : 4 Kbytes      Block size : 8 Kbytes</p> <p>Addresses which can be ***** (Address FFFF<sub>16</sub> is not included; <b>Note 1</b>)</p>  <p>Addresses which can be ***** (Address FFFF<sub>16</sub> is not included; <b>Note 1</b>)</p> 
Page 45, Fig. 33	<p>Block size : 8 Mbytes</p> <p>Addresses which can be ***** (Addresses 0<sub>16</sub> and FF000<sub>16</sub> are not included; <b>Note 1</b>)</p> 	<p>Block size : 8 Mbytes</p> <p>Addresses which can be ***** (Addresses 0<sub>16</sub> and FF000<sub>16</sub> to FFFFF<sub>16</sub> are not included; <b>Note 1</b>)</p> 
Page 45, Fig. 33, title	Fig. 33 Area $\overline{CS_0}/\overline{CS_1}/\overline{CS_2}$ (mode 1) and area $\overline{CS_3}$	Fig. 33 Area $\overline{CS_0}/\overline{CS_1}/\overline{CS_2}$ (mode 0) and area $\overline{CS_3}$
Page 46, Left column, Line 2	Table 8 shows the interrupt <u>types</u> and the *****	Table 8 shows the interrupt <u>sources</u> and the *****
Page 46, Table 8, title	Table 8. Interrupt <u>types</u> and the interrupt vector addresses	Table 8. Interrupt <u>sources</u> and interrupt vector addresses
Page 52, Left column, Line 5	To use these pins as timer input pins, the <u>data</u> direction register *****	To use these pins as timer input pins, the <u>port</u> direction register *****
Page 55, Fig. 46, bit 4	 <p>0 : Increment or decrement according to up/down <u>flag</u> 1 : *****</p>	 <p>0 : Increment or decrement according to up/down <u>bit</u> 1 : *****</p>
★ Page 59, Left column, Lines 14, 17, 22	***** timer <u>A<sub>i</sub></u> start bit *****	***** <u>count</u> start bit *****
★ Page 62, (2) Event counter mode [01]	(Line 15) particular function select register 1 (bit <u>7</u> at address 63 <sub>16</sub> ) *****	(Line 15) particular function select register 1 (bit <u>6</u> at address 63 <sub>16</sub> ) *****
Page 64, Fig. 64		

# Corrections and Supplementary Explanation for M37902FxC Datasheet (REV.B) NO.7

Page	Error	Correction												
Page 64, Fig. 65, bits 2 to 0, bit 5, bit 6	<p>Serial I/O mode select bits 0 0 0 : Serial I/O mode is invalid. .... 0 0 1 : .....</p> <p>Even/Odd parity select bit ..... 0 : .....</p> <p>Parity enable select bit ..... 0 : .....</p>	<p>Serial I/O mode select bits 0 0 0 : Serial I/O is invalid. .... 0 0 1 : .....</p> <p>Odd/Even parity select bit ..... 0 : .....</p> <p>Parity enable bit ..... 0 : .....</p>												
Page 66, Fig. 68, UART0/1 transmit/receive control register 0, bit 6	<p>CLK polarity select bit ..... 0 : At the falling ....., receive data is input.</p>	<p>CLK polarity select bit ..... 0 : At the falling ....., receive data is input. When not in transfer, pin CLK's level is "H".</p>												
Page 68, Left column, Last line	read out the $\overline{RTS}_k$ output turns back to "L". .....	read out the $\overline{RTS}_k$ output turns back to "L". .....												
Page 70, Fig. 71	<p>■ CLK porarity select bit = <u>1</u></p> <p>■ CLK porarity select bit = <u>0</u></p>	<p>■ CLK porarity select bit = <u>0</u></p> <p>■ CLK porarity select bit = <u>1</u></p>												
★ Page 74, Table 13	<table border="1"> <tr> <th colspan="2">Functions</th> </tr> <tr> <td>Pin P80/CTS0/RTS0 (Note 1)</td> <td>Pin P81/...</td> </tr> <tr> <td>CTS2</td> <td>P81 or CLK0</td> </tr> </table>	Functions		Pin P80/CTS0/RTS0 (Note 1)	Pin P81/...	CTS2	P81 or CLK0	<table border="1"> <tr> <th colspan="2">Functions</th> </tr> <tr> <td>Pin P80/CTS0/RTS0 (Note 1)</td> <td>Pin P81/...</td> </tr> <tr> <td>CTS0</td> <td>P81 or CLK0</td> </tr> </table>	Functions		Pin P80/CTS0/RTS0 (Note 1)	Pin P81/...	CTS0	P81 or CLK0
Functions														
Pin P80/CTS0/RTS0 (Note 1)	Pin P81/...													
CTS2	P81 or CLK0													
Functions														
Pin P80/CTS0/RTS0 (Note 1)	Pin P81/...													
CTS0	P81 or CLK0													
★ Page 76, Fig. 77	<p>Ladder network</p>	<p>Resistor ladder network</p>												
Page 77, Left column, Line 12	$\overline{ADTRG}$ input changes from "H" to "L" (or "L" to "H"). .....	$\overline{ADTRG}$ input changes from "H" to "L" (or "L" to "H"). .....												
Page 77, Left column, Line 14	$\overline{ADTRG}$ pin is multiplexed with an analog voltage .....	$\overline{ADTRG}$ pin is multiplexed with an analog voltage .....												
★ Page 77, Right column, Lines 5 to 6	..... the ladder network or not .....	..... the resistor ladder network or not .....												
★ Page 77, Right column, Line 10	the ladder network can be cut off by disconnecting ladder network .....	the resistor ladder network can be cut off by disconnecting resistor ladder network .....												
★ Page 80, Left column, Line 10	....., the corresponding pin ( $DA_0$ to $DA_2$ ) outputs .....	....., the corresponding pin ( $D-A_0$ to $D-A_2$ ) outputs .....												

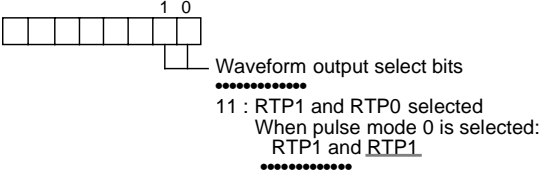
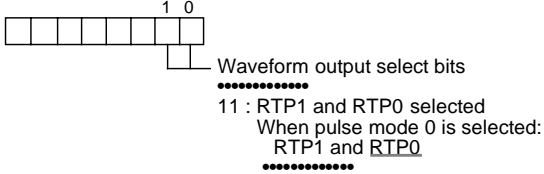
# Corrections and Supplementary Explanation for M37902FxC Datasheet (REV.B) NO.8

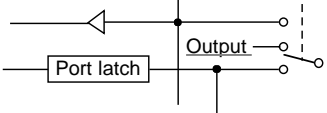
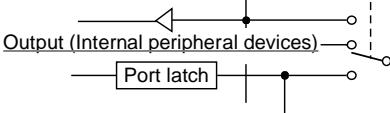
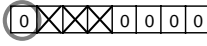
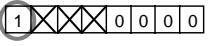
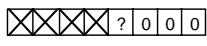
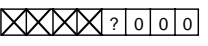
Page	Error	Correction
Page 80, Left column, Line 15	The D-A output enable bit is cleared to "0" at reset. ....	The contents of the corresponding D-A output enable bit and D-A register are cleared to "0" at reset. ....
Page 80, Right column, Line 1	with pin D-Ai.	with pin D-Ai. Also, when not using the D-A converter, be sure to clear the contents of the corresponding D-A output enable bit and D-A register to "0".
Page 81, Fig. 83, bits 1 and 0		
★ Page 82, Right column, Lines 1 to 3	When the waveform output select bits are set to "11" (bit 1 = bit 0 = "1"), RTP1 <sub>3</sub> to RTP1 <sub>0</sub> and RTP0 <sub>3</sub> to RTP0 <sub>0</sub> become pulse output port pins. When the waveform output .....	When the waveform output select bits are set to "11" (bit 1 = bit 0 = "1"), pulse output port pins are divided into two groups; one consists of RTP1 <sub>3</sub> to RTP1 <sub>0</sub> , RTP0 <sub>3</sub> , RTP0 <sub>2</sub> and the other consists of RTP0 <sub>1</sub> and RTP0 <sub>0</sub> . When the waveform output .....
Page 86, Fig. 91, bits 2 to 0		
Page 87, Fig. 89, 2nd diagram	[Inside dotted-line not included] P4 <sub>0</sub> /ALE, P4 <sub>1</sub> /φ <sub>1</sub> , P4 <sub>2</sub> /HLDA. .....	[Inside dotted-line not included] P4 <sub>0</sub> /ALE, P4 <sub>1</sub> /φ <sub>1</sub> , P4 <sub>2</sub> /HLDA. .....
		
Page 88, Fig. 90, 3rd diagram	[Inside dotted-line not included] P7 <sub>7</sub> /AN <sub>7</sub> /AD <sub>TRG</sub> /DA <sub>1</sub> /(INT <sub>2</sub> )	[Inside dotted-line included] P7 <sub>7</sub> /AN <sub>7</sub> /AD <sub>TRG</sub> /DA <sub>1</sub> /(INT <sub>2</sub> )
★ Page 89, Fig. 93, address 81 <sub>16</sub>	CS <sub>0</sub> control register H (81 <sub>16</sub> ) .... 	CS <sub>0</sub> control register H (81 <sub>16</sub> ) .... 
Page 90, Fig. 92, address 70 <sub>16</sub>	A-D interrupt control register (70 <sub>16</sub> ) .... 	A-D conversion interrupt control register (70 <sub>16</sub> ) ... 
★ Page 91, Left column, Lines 11, 12	....., the oscillation circuit stops its operation and resumes the current dissipation.	....., the oscillation circuit stops its operation, and the current dissipation is reduced.
★ Page 91, Left column, Line 17	..... from pin X <sub>IN</sub> and output a multiplied clock.	..... from pin X <sub>IN</sub> and generates a multiplied clock.
Page 92, Right column, Lines 4 to 5	..... In this selection, be sure that multiplied f(X <sub>IN</sub> ) does not exceed 26 MHz. ....	..... The PLL multiplication ratio must be set so that the frequency of the PLL output clock (f <sub>PLL</sub> ) must be in the range from 10 MHz to 26 MHz. ....
Page 92, Right column, Lines 10 to 11	..... the PLL output clock (f <sub>PLL</sub> ). (In other words, set bit 5 to "1".)	..... the PLL output clock (f <sub>PLL</sub> ). (In other words, set bit 5 to "1".) Note that, after reset, the PLL multiplication ratio select bits are allowed to be changed only once.

## Corrections and Supplementary Explanation for M37902FxC Datasheet (REV.B) NO.9

Page	Error	Correction
Page 92, Table 15, <b>Note</b>	<b>Note:</b> Be sure that system clock $f_{SYS}$ does not exceed 26 MHz. $f(X_{IN})$ means the frequency of the input clock from pin $X_{IN}$ ( $fX_{IN}$ ).	<b>Note:</b> The PLL multiplication ratio must be set so that the frequency of the PLL output clock ( $f_{PLL}$ ) must be in the range from 10 MHz to 26 MHz. $f(X_{IN})$ means the frequency of the input clock from pin $X_{IN}$ ( $fX_{IN}$ ). After reset, the PLL multiplication ratio select bits are allowed to be changed only once.
★ Page 96, Left column, Line 7	..... the oscillation circuit and PLL circuit have been restarted .....	..... the oscillation circuit has been restarted .....
★ Page 98, Right column, Line 8	the ladder network of the A-D converter will .....	the resistor ladder network of the A-D converter will .....
★ Page 98, Right column, Line 10	pin $V_{REF}$ to the ladder network, and the power dissipation .....	pin $V_{REF}$ to the resistor ladder network, and the power dissipation .....
★ Page 101, Fig. 106	Fig. 106. M37902FJCGP, M37902FJCHP : block configuration of internal flash memory	Fig. 106. M37902FJCHP : block configuration of internal flash memory
★	————— M37902F8CGP, M37902F8CHP : block configuration of internal flash memory	(Deleted)
★	————— M37902FECGP, M37902FECHP : block configuration of internal flash memory	(Deleted)
★ Page 102, Fig. 107	Fig. 108. M37902FCCGP, M37902FCCHP : block configuration of internal flash memory	Fig. 107. M37902FCCHP : block configuration of internal flash memory
★ Page 102, Fig. 108	Fig. 110. M37902FGCGP, M37902FGCHP : block configuration of internal flash memory	Fig. 108. M37902FGCHP : block configuration of internal flash memory
★	————— M37902FHCGP, M37902FHCHP : block configuration of internal flash memory	(Deleted)
★ Page 103, Right column, Lines 15 to 17	area if the user uses the flash memory serial I/O mode. Note that, when the boot ROM area is read .....	area if the user uses the flash memory serial I/O mode. Addresses $FFB0_{16}$ to $FFBF_{16}$ are the reserved area for the serial programmer. Therefore, when the user uses the flash memory serial I/O mode, do not program to this area. Note that, when the boot ROM area is read .....
★	————— Pin connection of M37902FxCGP in flash memory serial I/O mode	(Deleted)
★ Page 106, Right column, After line 13	program the user ROM area.	program the user ROM area. After reset removal, be sure not to change the status at pins MD0 and MD1.
★ Page 106, Fig. 114, Notes 4	4: Valid only ..... clear to "0".	4: Valid only ..... clear to "0". This bit 3 must be controlled with bit 1 = "1".
★ Page 107, Left column, Lines 16 to 20	..... command consists of 8-bit units must be written only to an even address; therefore, any data written to an odd address will be invalid. The write state .....	..... command consisting of 8 bits must be written to an even address; therefore, any command written to an odd address will be invalid. Since the write data at the 2nd cycle of a programming command consists of 16 bits, this data must be written to even and odd addresses. The write state .....
★ Page 107, Right column, After line 24	request occurrence.	request occurrence. In the CPU reprogramming mode, be sure not to use the STP and WIT instructions.

# Corrections and Supplementary Explanation for M37902FxC Datasheet (REV.B) NO.10

Page	Error	Correction																								
★ Page 108, Fig. 115	<p style="text-align: center;">↓</p> <div style="border: 1px solid black; padding: 5px; width: fit-content; margin: 0 auto;">                     The CPU reprogramming mode select bit is set to "1".                      (Writing of "0" → Writing of "1")                 </div> <p style="text-align: center;">↓</p>	<p style="text-align: center;">↓</p> <div style="border: 1px solid black; padding: 5px; width: fit-content; margin: 0 auto;">                     Writing of "1" to the CPU reprogramming mode select bit.                      (Writing of "0" → Writing of "1")                 </div> <p style="text-align: center;">↓</p>																								
★ Page 108, Software Commands	(Lines 6, 7) ••••• (D8–D15) is ignored.	(Lines 6, 7) ••••• (D8–D15) is ignored. (Except for the write data at the 2nd cycle of a page programming command.)																								
★ Page 108, Page programming Command	(Title) Page Program Command (4116)  (After line 20) ••••• mode is maintained.	(Title) Page Programming Command (4116)  (After line 20) ••••• mode is maintained. In continuous programming, if there is no programming error, page programming commands can be executed with the read status register mode kept.																								
★ Page 109, Page programming Command	(Lines 4 to 7) •••••, the same way as bit 7 of the status register. Reading out the •••••	(Lines 4 to 7) •••••, the same way as bit 7 of the status register. Before execution of the next command, be sure to verify that bit 7 of the status register (SR.7) or the RY/BY status bit is set to "1" (READY). During the automatic programming operation, writing of commands and access to the flash memory must not be performed. Reading out the •••••																								
★ Page 109, Block Erase Command	(Lines 20 to 23) •••••, the same way as bit 7 of the status register. Reading out the •••••	(Lines 20 to 23) •••••, the same way as bit 7 of the status register. Before execution of the next command, be sure to verify that bit 7 of the status register (SR.7) or the RY/BY status bit is set to "1" (READY). During the automatic erase operation, writing of commands and access to the flash memory must not be performed. Reading out the •••••																								
★ Page 111, Erase All Unlocked Block Command	(Lines 9 to 11) ••••• is also reported by a read of the status register. When the lock bit •••••	(Lines 9 to 11) ••••• is also reported by a read of the status register. During the automatic erase operation (when the RY/BY status bit = "0"), writing of commands and access to the flash memory must not be performed. When the lock bit •••••																								
★ Page 111, Data Protect Function (Block Lock)	(After line 20) lock bit is terminated.	(After line 20) lock bit is terminated. To perform erase or programming, be sure to do one of the following. • By executing the read lock bit status command, verify that the lock of the target block is invalid. • Set the lock bit invalidity select bit to "1" to invalidate the lock. When the block erase or programming is performed with the lock valid, the erase status bit (SR.5) and programming status bit (SR.4) are set to "1" (terminated by error).																								
★ Page 114, ABSOLUTE MAXIMUM RATINGS	<table border="1" style="width: 100%; border-collapse: collapse;"> <thead> <tr> <th style="width: 10%;">Symbol</th> <th style="width: 40%;">Parameter</th> <th style="width: 20%;">Ratings</th> <th style="width: 30%;">Unit</th> </tr> </thead> <tbody> <tr> <td>Pd</td> <td>Power dissipation</td> <td style="text-align: center;">300</td> <td>mW</td> </tr> <tr> <td>Topr</td> <td>Operating temperature</td> <td></td> <td></td> </tr> </tbody> </table>	Symbol	Parameter	Ratings	Unit	Pd	Power dissipation	300	mW	Topr	Operating temperature			<table border="1" style="width: 100%; border-collapse: collapse;"> <thead> <tr> <th style="width: 10%;">Symbol</th> <th style="width: 40%;">Parameter</th> <th style="width: 20%;">Ratings</th> <th style="width: 30%;">Unit</th> </tr> </thead> <tbody> <tr> <td>Pd</td> <td>Power dissipation</td> <td style="text-align: center;">400</td> <td>mW</td> </tr> <tr> <td>Topr</td> <td>Operating ambient temperature</td> <td></td> <td></td> </tr> </tbody> </table>	Symbol	Parameter	Ratings	Unit	Pd	Power dissipation	400	mW	Topr	Operating ambient temperature		
Symbol	Parameter	Ratings	Unit																							
Pd	Power dissipation	300	mW																							
Topr	Operating temperature																									
Symbol	Parameter	Ratings	Unit																							
Pd	Power dissipation	400	mW																							
Topr	Operating ambient temperature																									

## Corrections and Supplementary Explanation for M37902FxC Datasheet (REV.B) NO.11

Page	Error	Correction
Page 114, RECOMMENDED OPERATING CONDITIONS	$f_{(sys)}$ External clock input frequency (Note 2) .....	$f_{(XIN)}$ External clock input frequency (Note 2) .....
★	$f_{(sys)}$ System clock frequency .....	$f_{(sys)}$ System clock frequency .....
★ Page 123, Timing Requirements	$t_{w(half)}$ External clock .....	$t_{w(half)}$ External clock .....
★ Page 131, PACKAGE OUTLINE	100P6S-A package outline	(Deleted)