

GF1A THRU GF1M

SURFACE MOUNT GLASS PASSIVATED JUNCTION RECTIFIER

Reverse Voltage - 50 to 1000 Volts Forward Current - 1.0 Ampere

PATENTED*

DO-214BA

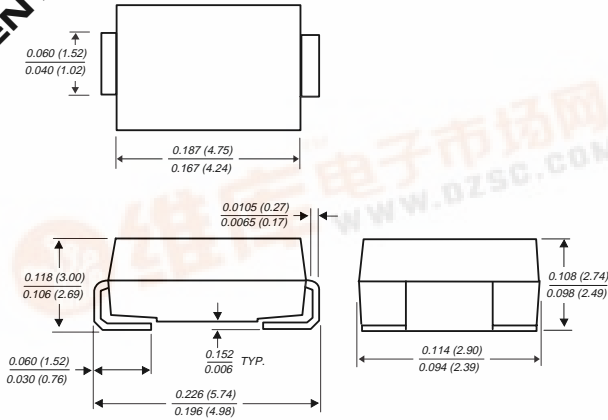

Dimensions in inches and (millimeters)

* Glass-plastic encapsulation technique is covered by Patent No. 3,996,602, brazed-lead assembly by Patent No. 3,930,306 and lead forming by Patent No. 5,151,846



FEATURES

- ◆ Plastic package has Underwriters Laboratory Flammability Classification 94V-0
- ◆ Ideal for surface mount automotive applications
- ◆ High temperature metallurgically bonded construction
- ◆ Glass passivated cavity-free junction
- ◆ Capable of meeting environmental standards of MIL-S-19500
- ◆ Built-in strain relief
- ◆ Easy pick and place
- ◆ High temperature soldering guaranteed: 450°C/5 seconds at terminals
- ◆ Complete device submersible temperature of 265°C for 10 seconds in solder bath



MECHANICAL DATA

Case: JEDEC DO-214BA molded plastic over glass body
Terminals: Solder plated, solderable per MIL-STD-750, Method 2026
Polarity: Color band denotes cathode end
Mounting Position: Any
Weight: 0.0048 ounces, 0.120 gram

MAXIMUM RATINGS AND ELECTRICAL CHARACTERISTICS

Ratings at 25°C ambient temperature unless otherwise specified.

	SYMBOLS	GF1A	GF1B	GF1D	GF1G	GF1J	GF1K	GF1M	UNITS
Device marking code		GA	GB	GD	GG	GJ	GK	GM	
Maximum repetitive peak reverse voltage	V _{RRM}	50	100	200	400	600	800	1000	Volts
Maximum RMS voltage	V _{RMS}	35	70	140	280	420	560	700	Volts
Maximum DC blocking voltage	V _{DC}	50	100	200	400	600	800	1000	Volts
Maximum average forward rectified current at T _L =125°C	I _(AV)	1.0							Amp
Peak forward surge current 8.3ms single half sine-wave superimposed on rated load (JEDEC Method)	I _{FSM}	30.0							Amps
Maximum instantaneous forward voltage at 1.0A	V _F	1.10					1.20		Volts
Maximum DC reverse current at rated DC blocking voltage T _A =25°C T _A =125°C	I _R	5.0 50.0					µA		
Typical reverse recovery time (NOTE 1)	t _{rr}	2.0					µs		
Typical junction capacitance (NOTE 2)	C _J	15.0					pF		
Typical thermal resistance (NOTE 3)	R _{θJA} R _{θJL}	80.0 26.0					°C/W		
Operating junction and storage temperature range	T _J , T _{STG}	-65 to +175							°C

NOTES:

- Reverse recovery test conditions: I_F=0.5A, I_R=1.0A, I_{rr}=0.25A Measured at 1.0 MHz and applied V_R=4.0 Volts
- Thermal resistance from junction to ambient and from junction to lead P.C.B. mounted on 0.2 x 0.2" (5.0 x 5.0mm) copper pad areas

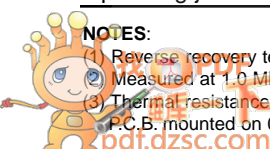

RATINGS AND CHARACTERISTIC CURVES GF1A THRU GF1M

FIG. 1 - FORWARD CURRENT DERATING CURVE

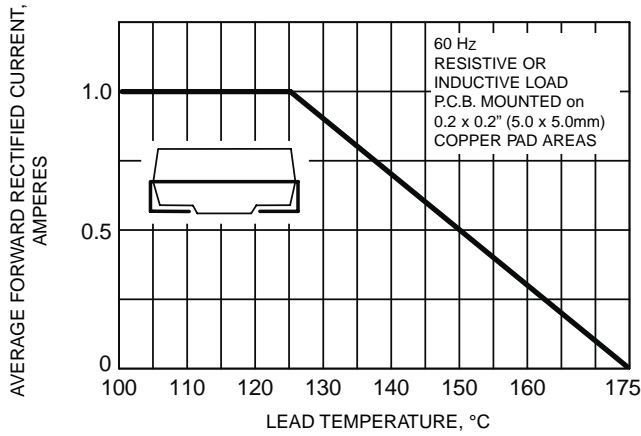

FIG. 2 - MAXIMUM NON-REPETITIVE PEAK FORWARD SURGE CURRENT

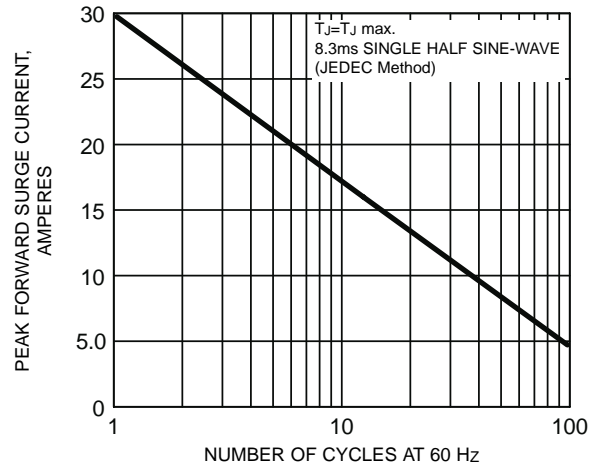

FIG. 3 - TYPICAL INSTANTANEOUS FORWARD CHARACTERISTICS

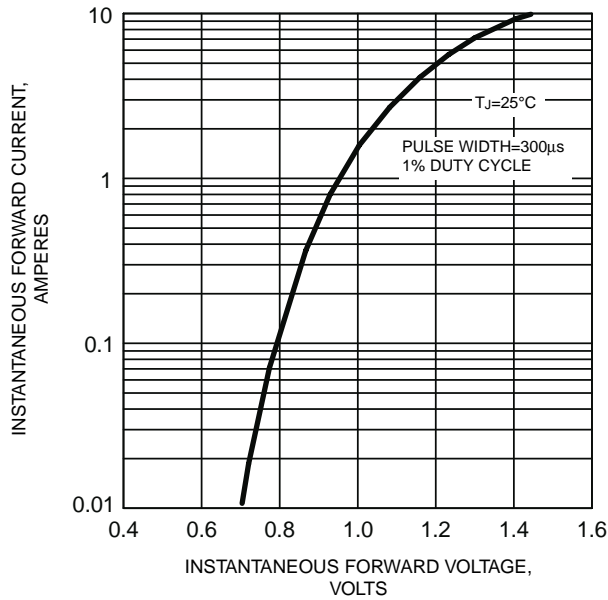

FIG. 4 - TYPICAL REVERSE CHARACTERISTICS

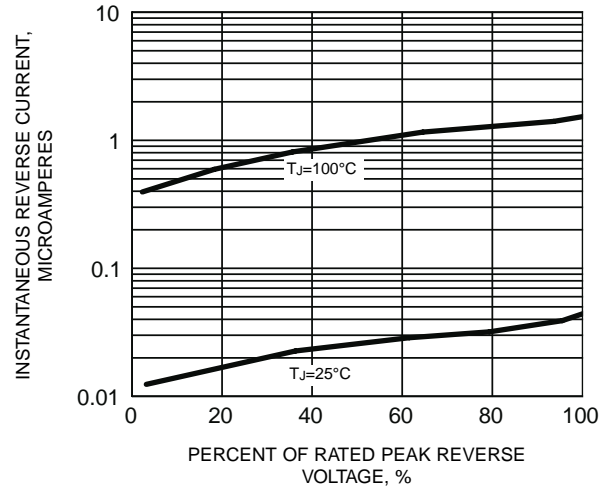

FIG. 5 - TYPICAL JUNCTION CAPACITANCE

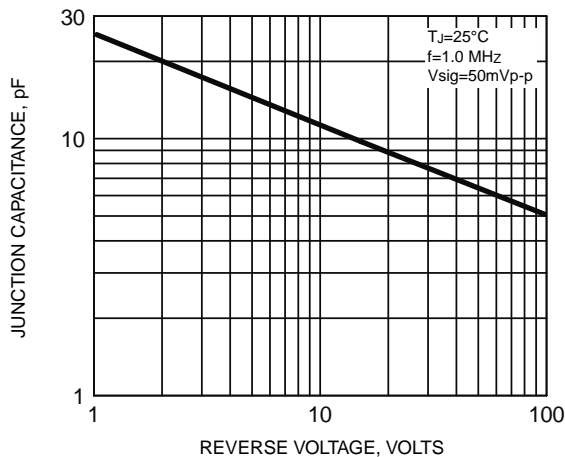

FIG. 6 - TYPICAL TRANSIENT THERMAL IMPEDANCE

