

GL3120 VIF+SIF CIRCUIT for TV Sets, VTR's

Description

The GL3120 is an IC containing the VIF section and SIF section on a single chip in the DIP30S package of shrink type. Since the GL3120 is capable of performing video detection and sound detection independently or simultaneously, it can be applied to various sets from popular type to high-grade type according to the designer's policy.

Function

VIF section: VIF amp, video detector, peak IF AGC, BW noise canceler, RF AGC, AFT, SIF detector
SIF section: SIF limiter amp, FM detector, DC attenuator, AF driver

Feature

- High Gain VIF Amp Requiring No Preamp
- High AGC Speed
- Provides Wide-Band Detection Characteristics and Meets Sound MPX Demodulation Requirements Because of FM Detection Being quadrature Detection.
- Possible to Use Sound REC Pin (Pin 2), Aux Pin (Pin 3)
- Possible to Mute Video, Sound for VTR:
Pin 7 GND: Muting of Both Video and Sound
Pin 29 GND: Muting of Sound Only

Block Diagram

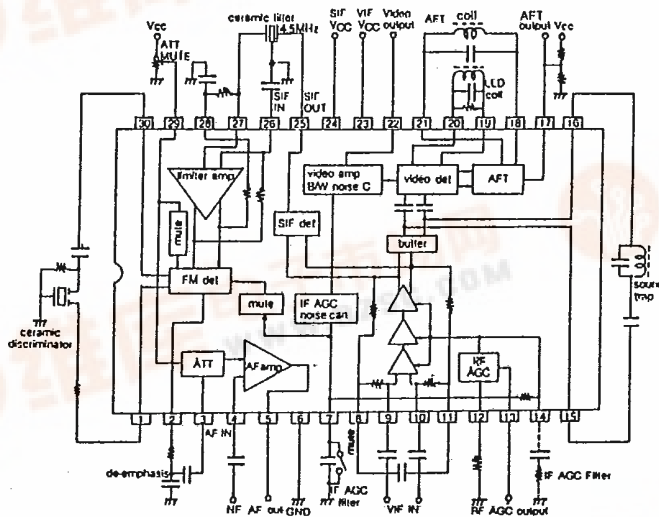

GL3120

T-77-07-13

Electrical Characteristics/ $T_A = 25^\circ\text{C}$, $V_{CC} = 12\text{V}$, $f_p = 58.75\text{MHz}$, $f_s = 54.25\text{MHz}$ (VIF), $f_o = 4.5\text{MHz}$ (SIF)

(VIF Section)

Parameter	Symbol	Condition	Min.	Typ.	Max.	Unit
Total circuit current	$I_{23} + I_{24}$	dc	59	74	98	mA
Maximum RF AGC voltage	V_{13H}	dc	8.5	8.9	9.2	V
Minimum RF AGC voltage	V_{13L}	dc		0	0.5	V
Quiescent video output voltage	V_{22}	dc	5.6	6.1	6.6	V
Quiescent AFT output voltage	V_{17}	dc	4.5	6.5	7.5	V
Input sensitivity	v_i	$f_m = 400\text{Hz} \text{ --- } 40\% \text{AM}$, $v_o = 0.8\text{vpp}$	30	36	42	$\text{dB}\mu$
AGC voltage	GR	$f_m = 15\text{kHz} \text{ --- } 78\% \text{AM}$, $v_o = \pm 1\text{dB}$	60	74	100	dB
Maximum allowable input voltage	$v_i \text{ max}$	$f_m = 15\text{kHz} \text{ --- } 78\% \text{AM}$, $v_o = \pm 1\text{dB}$	100	500	900	mVrms
Video output amplitude	v_{o22}	$v_i = 10^*$, $f_m = 15\text{kHz} \text{ --- } 78\% \text{AM}$	1.9	2.2	2.5	Vpp
Output S/N	S/N	$v_i = 10^*$, CW	48	54		dB
Carrier leak	CL	$v_i = 100^*$, $f_m = 15\text{kHz} \text{ --- } 78\% \text{AM}$	50	57		dB
Maximum AFT voltage	V_{17H}	$v_i = 10^*$, SWEEP	11.0	11.5	12.0	V
Minimum AFT voltage	V_{17L}	$v_i = 10^*$, SWEEP	0	0.4	1.0	V
AFT Detection sensitivity	sf	$v_i = 10^*$, SWEEP	70	100	140	mV/kHz
White noise threshold voltage	V_{WTH}	$v_i = 10^*$, SWEEP	6.4	6.8	7.2	V
White noise clamp level	V_{WCL}	$v_i = 1^*$, SWEEP	4.2	4.6	5.0	V
Black noise threshold voltage	V_{BTH}	$v_i = 10^*$, SWEEP	2.1	2.4	2.7	V
Black noise clamp level	V_{BCL}	$v_i = 10^*$, SWEEP	3.8	4.2	4.6	V
SIF output signal voltage	v_{o25}	P/S = 20dB	40	60	100	mVrms
Frequency characteristic	f_c	-3dB	6	8	15	MHz
Differential gain	DG	$v_i = 10^*$, -87.5%, video-mode	0	4	10	%
Differential phase	DP	$v_i = 10^*$, -87.5%, video-mode	0	3	6	deg
Input resistance	r_i		1.0	1.5	2.0	$\text{k}\Omega$
Input capacitance	c_i			3.5	7.0	pF

Electronic volume control characteristic

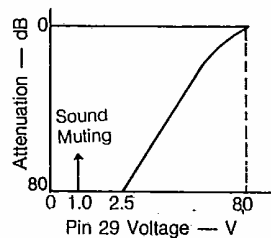

GL3120

T-77-07-13

(SIF Section)

Parameter	Symbol	Conditions	Min.	Typ.	Max.	Unit
SIF limiting sensitivity	ViLim	-3dB	0	200	400	μVrms
Detection output voltage	Vo2	vi = 100*, fm = 400Hz, Δf = ±25kHz	450	680	850	mVrms
Total harmonic distortion	THD	vi = 100*, fm = 400Hz, Δf = ±25kHz		0.5	1.0	%
AM rejection	AMR	vi = 100*, fm = 400Hz, √Δf = ±25kHz, -30%AM	50	60	100	dB
DCVR maximum attenuation	ATT	vi = 200*, f = 400Hz	70	80		dB
AF amp gain	VGAF	vi = 100*, f = 400Hz	18	20	22	dB
AF amp output voltage	vo5	THD = 10%, f = 400Hz	3	4		Vrms

(Note)

- FM detector input impedance (pin 30): 2k Ω (typ.)
- *: mVrms

Typical Application

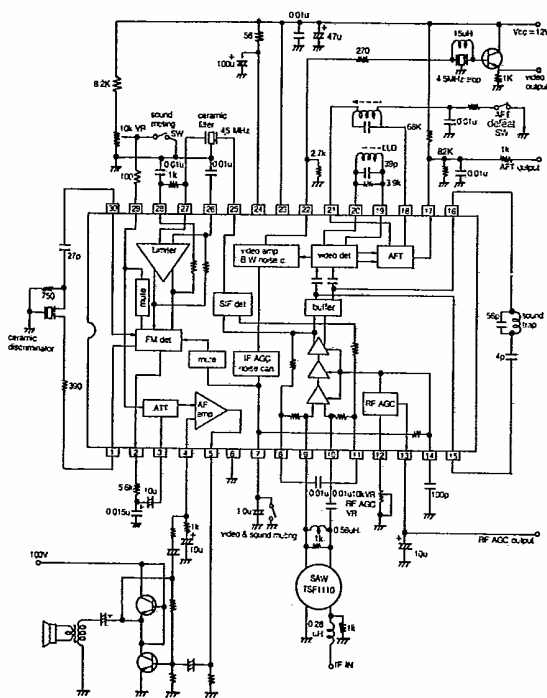

GL3120

T-77-07-13

Pin Configuration

