

GL3276A

Description

The GL3276A is a bipolar analog ICs specifically developed for use in infrared remote control system receiving preamplifiers. Capable of accepting a photodiode directly, these ICs house a high gain initial amplifier, a limiter, a band-pass filter, a detection circuit and a waveform shaping circuit assembled on a single chip.

Features

- Less changes of malfunction associated with a high-frequency lighting flourscent lamp internal trap circuit.
- The central frequency can be varied with an external resistance:
 $f_0=30$ to 80KHz
 f_0 rimming reduce central frequency variance.
- Few external parts.
 Internal pull-up resistance and power filter resistance.
 Lower-capacitance external capacitor
- Open collector output
 Open collector output with a pull-up resistance.

Pin configuration

(SOP)

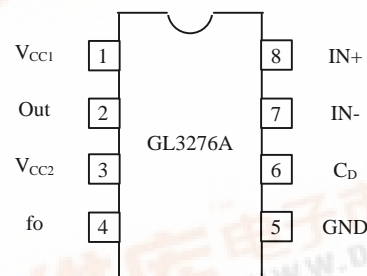

Block Diagram

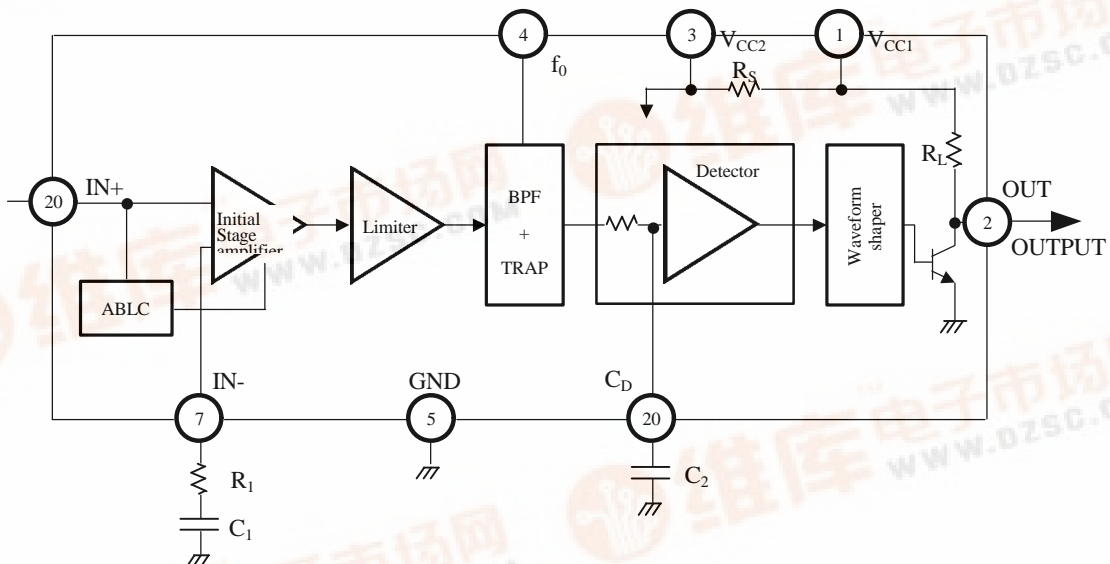

Absolute Maximum Ratings($T_a=25$; °C)

SYMBOL	PARAMETER	VALUE	UNIT
V_{CC}	Supply voltage	6.0	V
I_{OUT}	Output Current	2.5	mA
P_D	Allowable power dissipation	270	mW
T_{OPR}	Operating temperature	- 20 to +75	°C
T_{STG}	Storage temperature	-40 to +125	°C

Recommended Operating Condition

SYMBOL	PARAMETER	MIN	TYP	MAX	UNIT
V_{CC}	Supply voltage	4.5	5.0	5.5	V
f_{IN}	Input frequency	30	38	80	KHz

Electrical characteristics ($V_{CC} = 5.0V$, $T_a = 2.5$; °C)

SYMBOL	PARAMETER	TEST CONDITION	MIN	TYP	MAX	UNIT	REMARK
I_{CC}	Supply current			1.2	2.8	mA	
V_{IN}	Input voltage	$I_{IN} = 0A$ $I_{IN} = -330 \mu A$	2.0 0.6	2.5 0.8	3.1 1.7	V	
A_V	Voltage gain	$f_{IN} = 38kHz$ $V_{IN} = 30 \mu V_{P-P}$	70	76	80	dB	
F_{BW}	BPF bandwidth	-3dB Bandwidth $V_{IN} = 30 \mu V_{P-P}$	2.0	2.5	3.0	KHz	
r_{IN}	Input impedance	$f_{IN} = 38kHz$ CW $V_{IN} = 0.2 \mu V_{P-P}$	80	110	160	$K\Omega$	note 1
t_{PW1}	Output pulse width	$f_{IN} = 38kHz$ burstwave $V_{IN} = 500 \mu V_{P-P}$	440		770	μS	note 1
t_{PW2}		$f_{IN} = 38kHz$ burstwave $V_{IN} = 50mV_{P-P}$	440		770	μS	
V_{OL}	Low Level output voltage			0.2	0.4	V	
V_{OH}	Low Level output voltage		4.8	5.0		V	

Note 1 : $r_{IN} = \frac{47}{(\frac{V_{IN}}{V_X}) - 1} K\Omega$ (where V_{IN} =input level, V_X =test value)

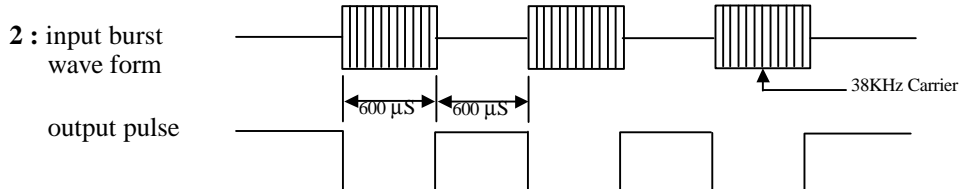

Pin Description

NO.	SYMBOL	PIN FUNCTION	
1	V _{CC1}	Power input	<ul style="list-style-type: none"> Apply a voltage of 5V ± 10% to pin 1. As the power is output to pin 3 through the internal power filter resistance, connect an electrolytic capacitor to pin 3.
3	V _{CC2}	Power output	
5	GND	Ground	
8	IN +	Input	<ul style="list-style-type: none"> With an internal impedance of 110 kΩ (typ.) pin 8 can accept a PIN photodiode directly. An automatic bias level control (ABLC) circuit prevents the input from being saturated by external light, assuring bias level stability for the input pin.
7	IN -	Initial amplifier Gain setup	<ul style="list-style-type: none"> Initial amplifier differential inverted output. Its gain can be set up with an external impedance.
4	f ₀	BPF frequency setup	<ul style="list-style-type: none"> The central frequency of the band-pass filter can be varied with an external resistance. A built-in trap circuit prevents malfunctions associated with a high-frequency lighting fluorescent lamp.
6	C _D	Detection capacitor	<ul style="list-style-type: none"> Pin to which a detection capacitor is connected.
2	OUT	Output	<ul style="list-style-type: none"> Open collector output with pull-up resistance. Its capability to drive a CMOS or TTL makes for easy connection with a receiving microcomputer. The GL3276A has an active low output.

Sample Application Circuits
8 Pin Plastic
SOP

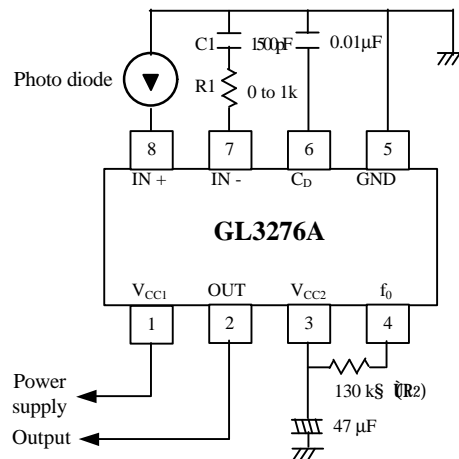

Typical Characteristics ($T_A = 25^\circ\text{C}$)

