

GL6840

# GL6840A

Electronic Two Tone Ringer

## Description

GL6840A are monolithic integrated circuits designed to replace the mechanical bell in telephone sets, in connection with an electro acoustical converter. The device can drive either directly a piezo ceramic converter(buzzer) or a small loudspeaker. In this case a transformer is needed. The two tone frequencies generated are switched by an internal oscillator in a fast sequence and made audible across output amplifiers in the transducer, both tone frequencies and switching frequency can be externally adjusted. The supply voltage is obtained from the AC rings signal and the circuit is designed so that noise on the line or variations on the ringing signal cannot affect the correct operation of the devices. The output bridge configuration allows to use a high impedance transducer with acoustical results much better than in a single ended configuration. The two outputs can also be connected independently to different converters or actuators(acoustical, opto and logic)

## Features

- Low current consumption, in order to allow the parallel operation of 4 devices
- Integrated rectifier bridge with zener diodes to protect against overvoltages
- Little external circuitry
- Tone and switching frequencies adjustable by  $V_{AB}$  external components
- Integrated voltage and current hysteresis
- Bridge output configuration

## Pin Configuration

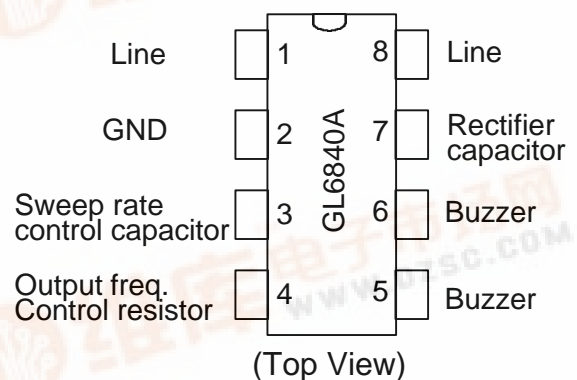

## Absolute Maximum Ratings

Calling Voltage( $f=50\text{S}$ ) $\hat{U}$	120Vrms
continuous	
Calling Voltage( $f=50\text{S}$ ) $\hat{U}$	200Vrms
5s ON/10s OFF	
Supply Current	22S $\hat{I}$
Operating Temperature	-20 to 75; $\hat{E}$
Storage Temperature	-65 to 150; $\hat{E}$

## Test Circuit

$$\text{For GL6840A } f_1 = \frac{3.26 \times 10^4}{R_1(\text{S } \hat{U})} \times (2 - e^{\frac{14 - R_1(\text{S } \hat{U})}{95}})$$

$$f_2 = 0.717 \times f_1 \quad f_{\text{sweep}} = \frac{1000}{C_1(\text{S } \hat{Y})}$$

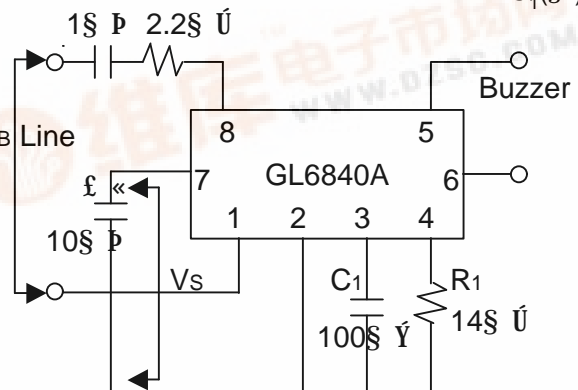

**Block Diagram**

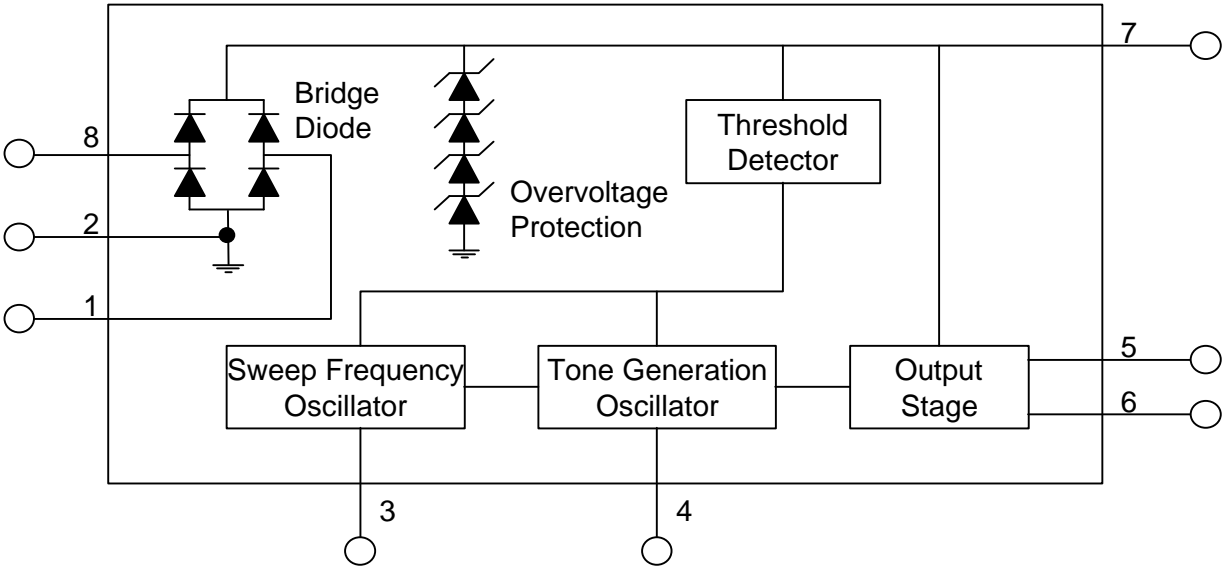

**Pin Description**

PIN	NAME	DESCRIPTION
1,8	LINE	Input terminals to bridge diode. The AC ringing signal from the telephone line drives the ringer through bridge.
2	GND	Ground
3	Sweep Rate Control Capacitor	This pin is connected to external capacitor to control the sweeping frequency( $f_{SWEEP}$ )
4	Output Frequency Control Resistor	This pin is connected to external resistor to control the two tone frequency( $f_1, f_2$ )
5,6	Buzzer	The tone ringer output terminals which have inverse output phase each others.
7	Rectifier Capacitor	This pin is connected to external capacitor to change AC ringing signal into DC voltage.

---

**Electrical Characteristics :  $T_A=25^\circ\text{C}$ ; unless otherwise specified**

PARAMETER	SYMBOL	CONDITIONS	MIN.	TYP.	MAX.	UNIT
Supply Voltage	$V_S(\text{pin}7)$				26	V
Current Consumption with load(pin 1-8)	$I_B$	$V_S=16.5$ to $29.5\text{V}$		1.2	1.8	$\mu\text{A}$
Activation Voltage	$V_{ON}$		12.3	13.3	14.4	V
Sustaining Voltage	$V_{OFF}$		8	8.9	9.7	V
Differential Resistance in OFF condition(pin 8-1)	$R_D$		6.4			$\Omega$
Output Voltage Swing	$V_{OUT}$			$V_S-5$		V
Short Circuit Current (pin 5-6)	$I_{OUT}$	$V_S=20\text{V}$		35		$\mu\text{A}$
Voltage Drop between pin 8-1 and pin 7-2	$V_D$			3		V
Output Frequencies		$V_S=26\text{V}$ $R_1=14\Omega$				
$F_{OUT1}$	$F_1$	$V_S=0\text{V}$	1.96	2.3	2.65	$\mu\text{s}$
$F_{OUT2}$	$F_2$	$V_S=6\text{V}$	1.42	1.67	1.92	
Programming Resistor Ratio			8		20	$\Omega$
Sweep Frequency	$F_{SWEEP}$	$C_1=100\text{pF}$	7	10	13	$\mu\text{s}$

---

Typical Application

Figure1 : Single output applied pin#5

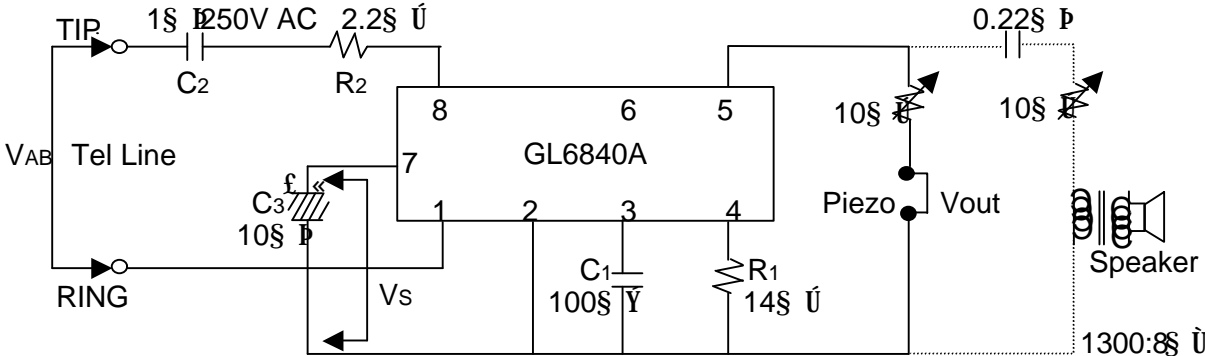
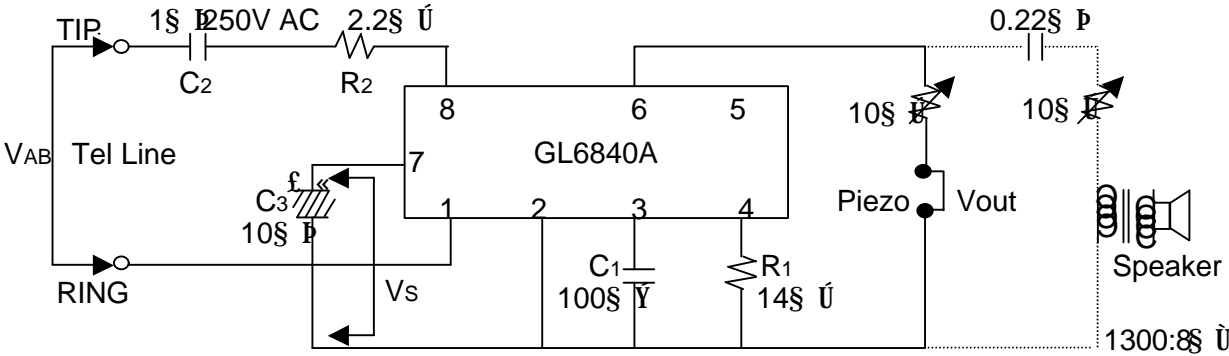
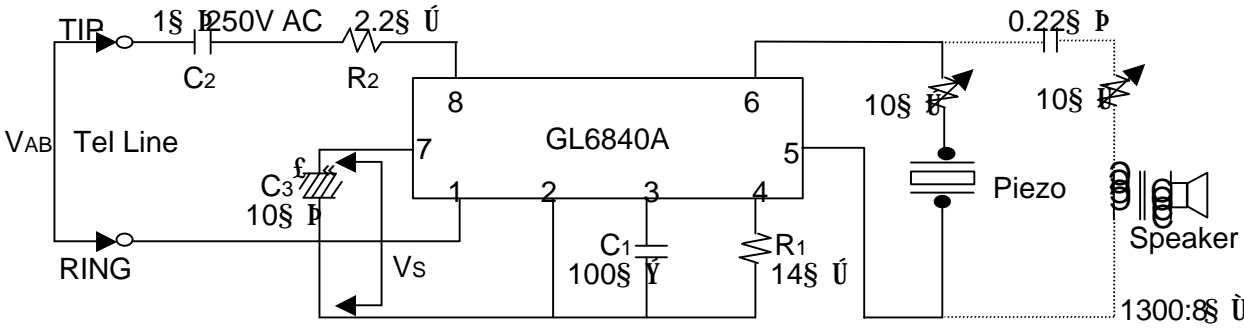

Figure2 : Single output applied pin#6



Note) Using a big size buzzer, pin#6 output is better than pin#5 output.

Figure3 : Differential output



# GL6840B

## Electronic Two Tone Ringer

### Description

GL6840B are monolithic integrated circuits designed to replace the mechanical bell in telephone sets, in connection with an electro acoustical converter. The device can drive either directly a piezo ceramic converter(buzzer) or a small loudspeaker. In this case a transformer is needed. The two tone frequencies generated are switched by an internal oscillator in a fast sequence and made audible across output amplifiers in the transducer, both tone frequencies and switching frequency can be externally adjusted. The supply voltage is obtained from the AC rings signal and the circuit is designed so that noise on the line or variations on the ringing signal cannot affect the correct operation of the devices. The output bridge configuration allows to use a high impedance transducer with acoustical results much better than in a single ended configuration. The two outputs can also be connected independently to different converters or actuators(acoustical, opto and logic)

### Features

- Low current consumption, in order to allow the parallel operation of 4 devices
- Integrated rectifier bridge with zener diodes to protect against overvoltages
- Little external circuitry
- Tone and switching frequencies adjustable by external components
- Integrated voltage and current hysteresis
- Bridge output configuration

### Pin Configuration

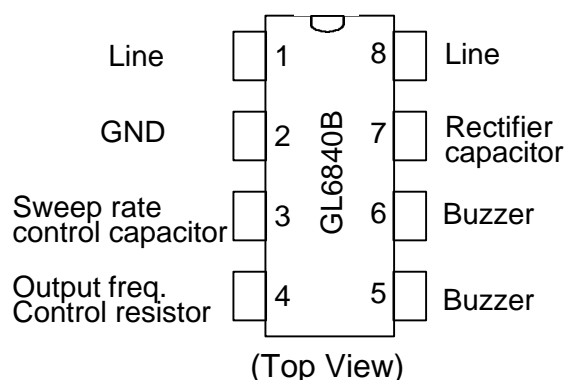

### Absolute Maximum Ratings

Calling Voltage(f=50\$ \hat{f})\$ continuous	120Vrms
Calling Voltage(f=50\$ \hat{f})\$ 5s ON/10s OFF	200Vrms
Supply Current	22\$ \hat{I}\$
Operating Temperature	-20 to 75; \hat{E}
Storage Temperature	-65 to 150; \hat{E}

### Test Circuit

$$\text{For GL6840B } f_1 = \frac{3.32 \times 10^4}{R_1(\$ \hat{f})} \times (2 - e^{-\frac{39 - R_1(\$ \hat{f})}{358}})$$

$$f_2 = 0.717 \times f_1 \quad f_{\text{sweep}} = \frac{1000}{C_1(\$ \hat{f})}$$

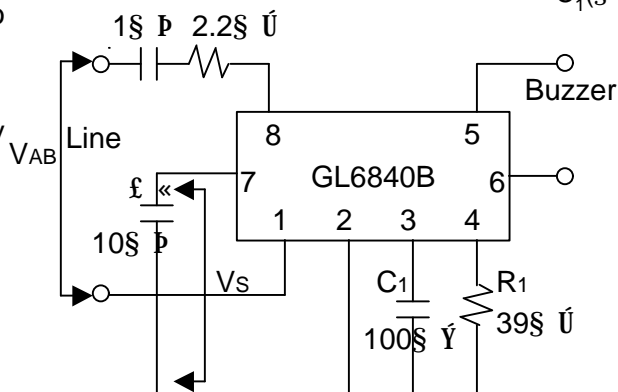

**Block Diagram**

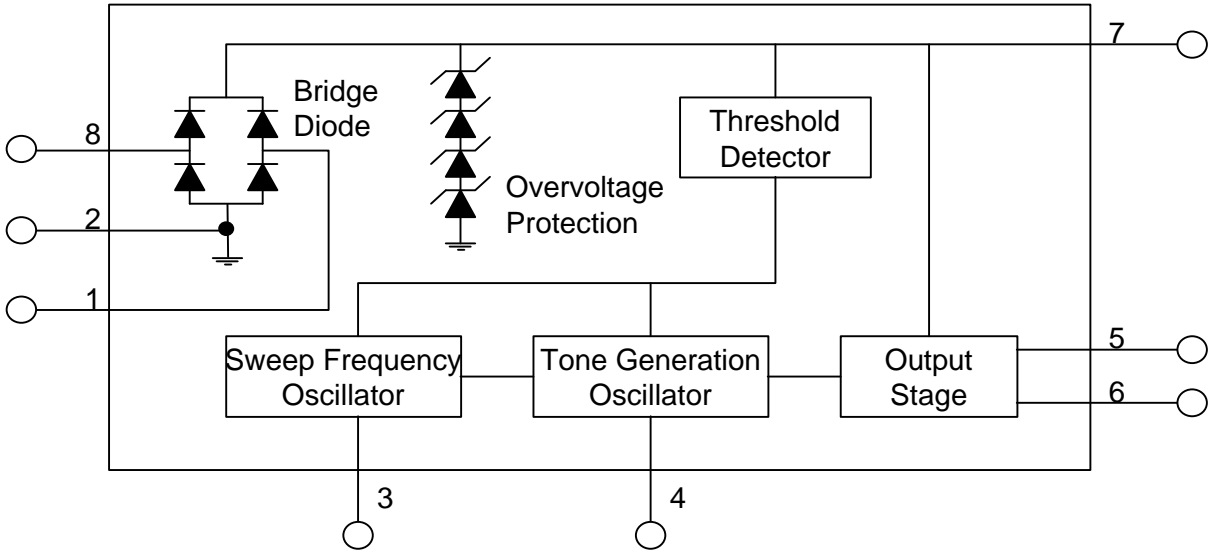

**Pin Description**

PIN	NAME	DESCRIPTION
1,8	LINE	Input terminals to bridge diode. The AC ringing signal from the telephone line drives the ringer through bridge.
2	GND	Ground
3	Sweep Rate Control Capacitor	This pin is connected to external capacitor to control the sweeping frequency( $f_{SWEEP}$ )
4	Output Frequency Control Resistor	This pin is connected to external resistor to control the two tone frequency( $f_1, f_2$ )
5,6	Buzzer	The tone ringer output terminals which have inverse output phase each others.
7	Rectifier Capacitor	This pin is connected to external capacitor to change AC ringing signal into DC voltage.

**Electrical Characteristics :  $T_A=25^\circ\text{C}$ ; unless otherwise specified**

PARAMETER	SYMBOL	CONDITIONS	MIN.	TYP.	MAX.	UNIT
Supply Voltage	$V_s(\text{pin}7)$				26	V
Current Consumption with load(pin 1-8)	$I_B$	$V_s=16.5$ to $29.5V$		1.2	1.8	$\mu\text{A}$
Activation Voltage	$V_{ON}$		12.3	13.3	14.4	V
Sustaining Voltage	$V_{OFF}$		8	8.9	9.7	V
Differential Resistance in OFF condition(pin 8-1)	$R_D$		6.4			$\Omega$
Output Voltage Swing	$V_{OUT}$			$V_s-5$		V
Short Circuit Current (pin 5-6)	$I_{OUT}$	$V_s=20V$		35		$\mu\text{A}$
Voltage Drop between pin 8-1 and pin 7-2	$V_D$			3		V
Output Frequencies		$V_s=26V$ $R_1=39\Omega$				
$F_{OUT1}$	$F_1$	$V_s=0V$	723	850	978	$\text{Hz}$
$F_{OUT2}$	$F_2$	$V_s=6V$	519	610	702	$\text{Hz}$
Programming Resistor Range			27		51	$\Omega$
Sweep Frequency	$F_{SWEEP}$	$C_1=100\text{pF}$	7	10	13	$\text{Hz}$

Typical Application

Figure1 : Single output applied pin#5

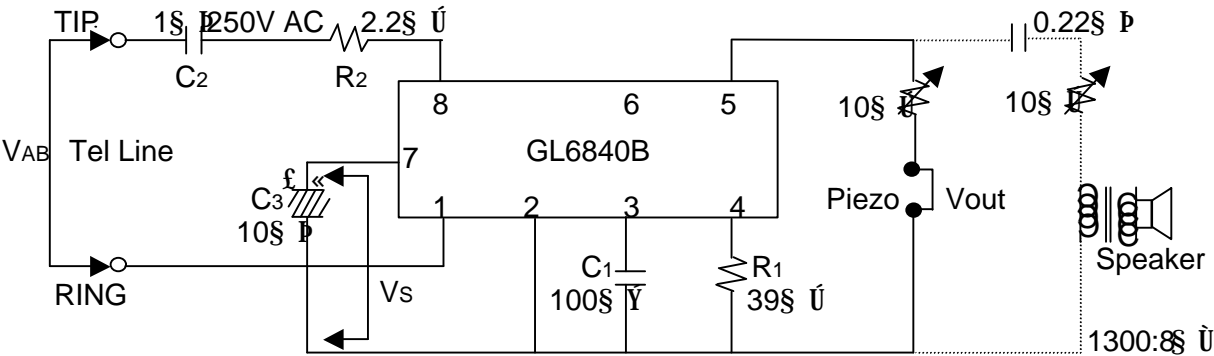
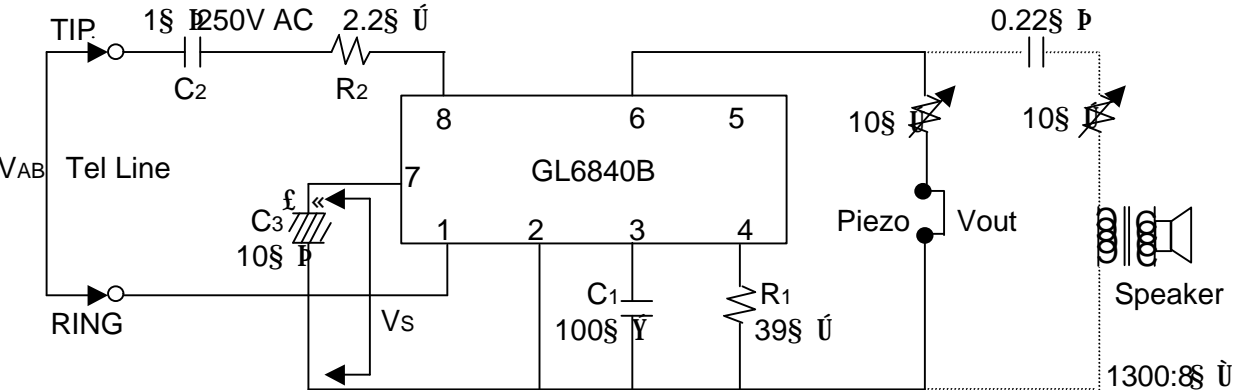

Figure2 : Single output applied pin#6



Note) Using a big size buzzer, pin#6 output is better than pin#5 output.

Figure3 : Differential output

