



Genesys Logic, Inc.

GL850

USB 2.0

4-PORT HUB Controller

Datasheet

Revision 1.11

Jun. 25, 2003



Copyright:

Copyright © 2003 Genesys Logic Incorporated. All rights reserved. No part of the materials may be reproduced in any form or by any means without prior written consent of Genesys Logic Inc..

Disclaimer:

ALL MATERIALS ARE PROVIDED "AS IS" WITHOUT EXPRESS OR IMPLIED WARRANTY OF ANY KIND. NO LICENSE OR RIGHT IS GRANTED UNDER ANY PATENT OR TRADEMARK OF GENESYS LOGIC INC.. GENESYS LOGIC HEREBY DISCLAIMS ALL WARRANTIES AND CONDITIONS IN REGARD TO MATERIALS, INCLUDING ALL WARRANTIES, IMPLIED OR EXPRESS, OF MERCHANTABILITY, FITNESS FOR ANY PARTICULAR PURPOSE, AND NON-INFRINGEMENT OF INTELLECTUAL PROPERTY. IN NO EVENT SHALL GENESYS LOGIC BE LIABLE FOR ANY DAMAGES INCLUDING, WITHOUT LIMITATION, DAMAGES RESULTING FROM LOSS OF INFORMATION OR PROFITS. PLEASE BE ADVISED THAT THE MATERIALS MAY CONTAIN ERRORS OR OMMISIONS. GENESYS LOGIC MAY MAKE CHANGES TO THE MATERIALS OR TO THE PRODUCTS DESCRIBED THEREIN AT ANY TIME WITHOUT NOTICE.

Trademarks:



is a registered trademark of Genesys Logic Inc..
All trademarks are the properties of their respective owners.

Office:

Genesys Logic, Inc.

12F, No. 205, Sec. 3, Beishin Rd., Shindian City,

Taipei, Taiwan

Tel: (886-2) 8913-1888

Fax: (886-2) 6629-6168

<http://www.genesyslogic.com>



Revision History

Revision	Date	Description
1.00	05/22/2003	First formal release
1.10	06/11/2003	Add Bus Power statement Gang/Individual mode setting modified
1.11	06/25/2003	Add "4 port" bus power statement



TABLE OF CONTENTS

CHAPTER 1 GENERAL DESCRIPTION.....	9
CHAPTER 2 FEATURES.....	10
CHAPTER 3 PIN ASSIGNMENT.....	11
3.1 PINOUTS	11
3.2 PIN LIST.....	12
3.3 PIN DESCRIPTIONS.....	13
CHAPTER 4 BLOCK DIAGRAM.....	15
CHAPTER 5 FUNCTION DESCRIPTION	16
5.1 GENERAL.....	16
5.1.1 USPORT Transceiver.....	16
5.1.2 PLL (Phase Lock Loop)	16
5.1.3 FRTIMER	16
5.1.4 μC	16
5.1.5 UTM (USB2.0 Transceiver Macrocell Interface)	16
5.1.6 USPORT logic	16
5.1.7 SIE (Serial Interface Engine).....	16
5.1.8 Control/Status register	16
5.1.9 REPEATER	17
5.1.10 TT (Transaction Translator)	17
5.1.11 REPEATER/TT routing logic	17
5.1.11.1 Connected to 1.1 Host/Hub	17
5.1.11.2 Connected to USB2.0 Host/Hub	18
5.1.12 DSPORT logic	18
5.1.13 DSPORT Transceiver.....	18
5.2 CONFIGURATION AND I/O SETTINGS	19
5.2.1 RESET# Setting	19
5.2.2 PGANG/SUSPND Setting	20
5.2.3 SELF/BUS Power Setting	21
5.2.4 LED Connections.....	22
5.2.5 EEPROM Setting.....	22
5.3 USB PROTOCOLS	23



- 5.3.1 Host Commands and Hub Answers 24
 - 5.3.1.1 Standard Requests 24
 - 5.3.1.2 Hub Class Requests 25
- 5.4 DESCRIPTORS 27
 - 5.4.1 Full Speed Case 27
 - 5.4.1.1 Device Descriptor 27
 - 5.4.1.2 Device Qualifier Descriptor 28
 - 5.4.1.3 Configuration Descriptor 28
 - 5.4.1.4 Interface Descriptor 29
 - 5.4.1.5 Endpoint Descriptor 29
 - 5.4.1.6 Other Speed Configuration Descriptor..... 30
 - 5.4.1.7 Interface Descriptor combined with Other Speed Configuration Descriptor 30
 - 5.4.1.8 Endpoint Descriptor combined with Other Speed Configuration Descriptor 31
 - 5.4.1.9 String Descriptor..... 31
 - 5.4.2 High Speed Case 32
 - 5.4.2.1 Device Descriptor 32
 - 5.4.2.2 Device Qualifier Descriptor 33
 - 5.4.2.3 Configuration Descriptor 33
 - 5.4.2.4 Interface Descriptor 34
 - 5.4.2.5 Endpoint Descriptor in Configuration Descriptor 34
 - 5.4.2.6 Other Speed Configuration Descriptor..... 35
 - 5.4.2.7 Interface Descriptor in Other Speed Configuration Descriptor..... 35
 - 5.4.2.8 Endpoint Descriptor in Other Speed Configuration Descriptor 36
 - 5.4.2.9 String Descriptor..... 36
 - 5.4.3 Hub Class Descriptor 37
- CHAPTER 6 ELECTRICAL CHARACTERISTICS 38
 - 6.1 MAXIMUM RATINGS 38
 - 6.2 DC CHARACTERISTICS 38
- CHAPTER 7 PACKAGE DIMENSION 40



LIST OF FIGURES

FIGURE 3.1 - PINOUT DIAGRAM	11
FIGURE 4.1 - BLOCK DIAGRAM.....	15
FIGURE 5.1 - OPERATING IN USB1.1 SCHEME.....	17
FIGURE 5.2 - OPERATING IN USB2.0 SCHEME.....	18
FIGURE 5.3 - RESET# (EXTERNAL RESET) SETTING AND APPLICATION.....	19
FIGURE 5.4 - POWER ON SEQUENCE OF GL850	20
FIGURE 5.5 - TIMING OF PGANG/SUSPND STRAPPING	20
FIGURE 5.6 - GANG MODE SETTING	21
FIGURE 5.7 - SELF/BUS POWER SETTING	21
FIGURE 5.8 - LED CONNECTION	22
FIGURE 5.9 - SCHEMATICS BETWEEN GL850 AND 93C46.....	23
FIGURE 7.1 - GL850 64 PIN LQFP PACKAGE	40



LIST OF TABLES

TABLE 3.1 - PIN LIST	12
TABLE 3.2 - PIN DESCRIPTIONS.....	13
TABLE 5.1 - 93C46 CONFIGURATION.....	22
TABLE 5.2 - STANDARD REQUEST LIST.....	24
TABLE 5.3 - HUB CLASS REQUESTS LIST.....	25
TABLE 5.4 - DEVICE DESCRIPTOR FOR FULL SPEED.....	27
TABLE 5.5 - DEVICE QUALIFIER FOR FULL SPEED.....	28
TABLE 5.6 - CONFIGURATION DESCRIPTOR FOR FULL SPEED.....	28
TABLE 5.7 - INTERFACE DESCRIPTOR FOR FULL SPEED.....	29
TABLE 5.8 - ENDPOINT DESCRIPTOR FOR FULL SPEED.....	29
TABLE 5.9 - OTHER SPEED CONFIGURATION DESCRIPTOR FOR FULL SPEED	30
TABLE 5.10 - OTHER SPEED INTERFACE DESCRIPTOR FOR FULL SPEED.....	30
TABLE 5.11 - OTHER SPEED ENDPOINT DESCRIPTOR FOR FULL SPEED	31
TABLE 5.12 - STRING INDEX0 FOR FULL SPEED	31
TABLE 5.13 - STRING INDEX1 FOR FULL SPEED	31
TABLE 5.14 - STRING INDEX2 FOR FULL SPEED.....	32
TABLE 5.15 - DEVICE DESCRIPTOR FOR HIGH SPEED.....	32
TABLE 5.16 - DEVICE QUALIFIER FOR HIGH SPEED	33
TABLE 5.17 - CONFIGURATION DESCRIPTOR FOR HIGH SPEED	33
TABLE 5.18 - INTERFACE DESCRIPTOR FOR HIGH SPEED.....	34
TABLE 5.19 - ENDPOINT DESCRIPTOR FOR HIGH SPEED	34
TABLE 5.20 - OTHER SPEED CONFIGURATION DESCRIPTOR FOR HIGH SPEED.....	35
TABLE 5.21 - OTHER SPEED INTERFACE DESCRIPTOR FOR HIGH SPEED	35
TABLE 5.22 - OTHER SPEED ENDPOINT DESCRIPTOR FOR HIGH SPEED	36
TABLE 5.23 - STRING INDEX0 FOR HIGH SPEED.....	36
TABLE 5.24 - STRING INDEX1 FOR HIGH SPEED.....	36
TABLE 5.25 - STRING INDEX2 FOR HIGH SPEED.....	36
TABLE 5.26 - HUB CLASS DESCRIPTOR	37



TABLE 6.1 - MAXIMUM RATINGS	38
TABLE 6.2 - DC CHARACTERISTICS EXCEPT USB SIGNALS	38
TABLE 6.3 - DC CHARACTERISTICS OF USB SIGNALS UNDER FS/LS MODE.....	38
TABLE 6.4 - DC CHARACTERISTICS OF USB SIGNALS UNDER HS MODE.....	39



CHAPTER 1 GENERAL DESCRIPTION

GL850 is a 4-port standard Universal Serial Bus (USB) hub controller complies with *Universal Serial Bus Specification Revision 2.0*. GL850 can be connected to an USB1.1 host/hub or an USB2.0 host/hub. When GL850 is connected to an USB1.1 host/hub, it works just like an USB1.1 hub; the upstream port will operate in full-speed (FS) and the downstream port can operate in full-speed or low-speed (LS). When GL850 is connected to an USB2.0 host/hub, it works as an USB2.0 hub; the upstream port will operate in high-speed (HS) and the downstream port can operate in high-speed, full-speed, or low-speed. The bandwidths of high speed, full speed, and low speed are 480 Mbps, 12 Mbps, and 1.5 Mbps respectively.

GL850 embeds an 8-bit RISC processor to manipulate the control/status registers and responds to the requests from USB host. Firmware of GL850 will control its general purpose I/O (GPIO) to access the external EEPROM and then respond to the host the customized PID and VID configured in the external EEPROM. GL850 responds to the host the default settings in the internal ROM if there exists no external EEPROM. GL850 is designed for customers with much flexibility. Customers can easily design GL850 as 4-port self/bus powered, individual/ganged mode, by setting the I/O pins of GL850 (Ref. to Chapter 5). The more complicated settings such as PID, VID, and number of downstream ports settings are easily achieved by programming the external EEPROM.

TT (transaction translator) is the main traffic control engine in an USB2.0 hub to handle the unbalanced traffic speed between the upstream port and the downstream ports. GL850 adopts single TT architecture, which shares the same TT buffer for all downstream devices.

Each downstream port of GL850 supports two-color (green/amber) status LEDs to indicate normal/abnormal status. The downstream ports of GL850 can be configured as individual mode or gang mode (4 ports as a group) for power management. Gang mode is very helpful for cost consideration, since we can use one poly-fuse, but not expensive power switch chips, to detect over current.

GL850 passes the current requirement ($< 2.5\text{mA}$) for bus-power mode when being suspended. The current consumption is smaller than 100mA for the GL850 silicon itself. The above requirements are necessary for a 4-port bus power hub. Under adequate PCB designing, GL850 provide a good choice for customers as a 4-port bus powered hub. Besides, GL850 can switch automatically between self-power mode and bus-power mode without re-plugging into the PC host. The slew rate control circuits and the power fail detection circuits inside this chip give better ESD and EMI abilities to GL850.

GL850 is designed mainly for stand-alone hub. It can also be integrated into PC motherboard or any other compound devices to support USB hub function.



CHAPTER 2 FEATURES

- Compliant to *USB specification Revision 2.0*
 - 4 downstream ports
 - Upstream port supports both high-speed (HS) and full-speed (FS) traffic
 - Downstream ports support HS, FS, and low-speed (LS) traffic
 - 1 control pipe (endpoint 0, 64-byte data payload) and 1 interrupt pipe (endpoint 1, 1-byte data payload)
 - Backward compatible to *USB specification Revision 1.1*
- On-chip 8-bit micro-processor
 - RISC-like architecture
 - USB optimized instruction set
 - Dual cycle instruction execution
 - Performance: 6 MIPS @ 12MHz
 - With 64-byte RAM and 2K internal ROM
 - Support customized PID, VID by reading external EEPROM
 - Support downstream port configuration by reading external EEPROM
- Single Transaction Translator (TT) architecture
 - Single TT shares the same TT control logics for all downstream port devices. This is the most cost effective solution for TT
- Each downstream port supports two-color status indicator, with automatic and manual modes compliant to USB specification Revision 2.0
- Support both individual and gang modes of power management and over-current detection for downstream ports
- Conform to bus power requirements
- Automatic switching between self-powered and bus-powered modes
- Integrated USB2.0 transceiver
- 0.35um CMOS technology
- PLL embedded with external 12 MHz crystal
- Operate on 3.3 Volts
- Improved output drivers with slew-rate control for EMI reduction
- Internal power-fail detection for ESD recovery
- 64-pin LQFP package
- Applications:
 - Stand-alone USB hub
 - PC motherboard USB hub, Ducking of notebook
 - Any compound device to support USB HUB function

CHAPTER 3 PIN ASSIGNMENT

3.1 Pinouts

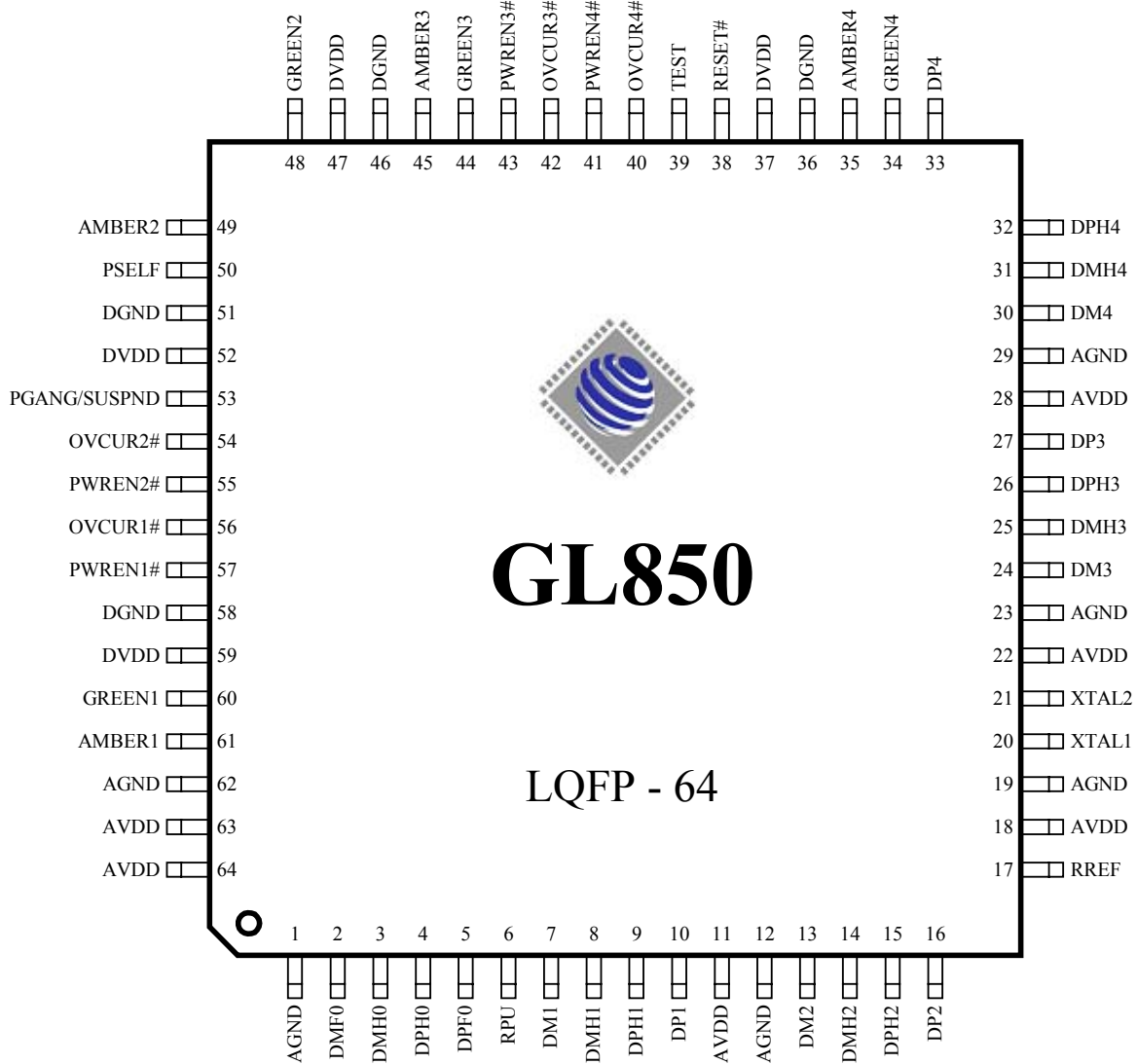

Figure 3.1 - Pinout Diagram



3.2 Pin List

Table 3.1 - Pin List

Pin#	Pin Name	Type	Pin#	Pin Name	Type	Pin#	Pin Name	Type	Pin#	Pin Name	Type
1	AGND	P	17	RREF	B	33	DP4	B	49	AMBER2	O
2	DMF0	B	18	AVDD	P	34	GREEN4	B	50	PSELF	I
3	DMH0	B	19	AGND	P	35	AMBER4	O	51	DGND	P
4	DPH0	B	20	XTAL1	I	36	DGND	P	52	DVDD	P
5	DPF0	B	21	XTAL2	O	37	DVDD	P	53	PGANG/ SUSPND	B
6	RPU	B	22	AVDD	P	38	RESET#	I	54	OVCUR2#	I
7	DM1	B	23	AGND	P	39	TEST	I	55	PWREN2#	O
8	DMH1	B	24	DM3	B	40	OVCUR4#	I	56	OVCUR1#	I
9	DPH1	B	25	DMH3	P	41	PWREN4#	O	57	PWREN1#	O
10	DP1	B	26	DPH3	P	42	OVCUR3#	I	58	DGND	P
11	AVDD	P	27	DP3	B	43	PWREN3#	O	59	DVDD	P
12	AGND	P	28	AVDD	P	44	GREEN3	B	60	GREEN1	O
13	DM2	B	29	AGND	P	45	AMBER3	O	61	AMBER1	O
14	DMH2	B	30	DM4	B	46	DGND	P	62	AGND	P
15	DPH2	B	31	DMH4	B	47	DVDD	P	63	AVDD	P
16	DP2	B	32	DPH4	B	48	GREEN2	O	64	AVDD	P



3.3 Pin Descriptions

Table 3.2 - Pin Descriptions

USB Interface			
Pin#	Pin Name	Type	Description
2,3,4,5	DMF0,DMH0, DPH0,DPF0	B	USB signals for USPORT
7,8,9,10	DM1,DMH1, DPH1,DP	B	USB signals for DSPORT1
13,14, 15,16	DM2,DMH2, DPH2,DP2	B	USB signals for DSPORT2
24,25, 26,27	DM3,DMH3, DPH3,DP3	B	USB signals for DSPORT3
30,31, 32,33	DM4,DMH4, DPH4,DP4	B	USB signals for DSPORT2
6	RPU	B	RPU connects 1.5K Ω resistor to 3.3V. RPU can be set to disconnected by externally resetting RESET#
17	RREF	B	A 510 Ω resistor must be connected between RREF and analog ground (AGND).

Note: USB signals must be carefully handled in PCB routing. For detailed information, please refer to **GL850 Design Guideline**.

HUB Interface			
Pin#	Pin Name	Type	Description
56,54, 42,40	OVCUR1#~ OVCUR4#	I (pu)	Active low. Over current indicator for DSPORT1~ DSPORT4 For GANG mode, OVCUR1# is the only over current flag for GL850
57,55, 43,41	PWREN1#~ PWREN4#	O (pu)	Active low. Power enable output for DSPORT1~ DSPORT4 For GANG mode, PWREN1# is the only power enable output for GL850.
60,48, 44,34	GREEN1~ GREEN4	O (pd)	Green LED indicator for DSPORT1~DSPORT4
61,49, 45,35	AMBER1~ AMBER4	O (pd)	Amber LED indicator for DSPORT4~DSPORT1 *AMBER[4~1] are also used to access the external EEPROM. For detailed information, please refer to Chapter 5.
50	PSELF	I	0: GL850 is bus-powered. 1: GL850 is self-powered.
53	PGANG/ SUSPND	B (pd)	This pin is default put in input mode after power-on reset. Individual/gang mode is strapped during this period. After the strapping period, this pin will be set to output mode, and then output high for normal mode. When GL850 is suspended, this pin will output low. *For detailed explanation, please see Chapter 5 Input: 0: individual, 1: gang Output: 0: suspend, 1: normal



Clock and Reset Interface			
Pin#	Pin Name	Type	Description
20	XTAL1	I	12MHz crystal clock input.
21	XTAL2	O	12MHz crystal clock output.
38	RESET#	I	Active low. External reset input, default pull high 100K Ω . When RESET# = low, whole chip is reset to the initial state.

System Interface			
Pin#	Pin Name	Type	Description
39	TEST	I (pd)	0: Normal operation. 1: Chip will be put in test mode.

Power / Ground			
Pin#	Pin Name	Type	Description
11,18, 22,28, 63,64	AVDD	P	Analog power input for analog circuits.
1,12,19, 23,29, 62	AGND	P	Analog ground input for analog circuits.
37,47, 52,59	DVDD	P	Digital power input for digital circuits.
36,46, 51,58	DGND	P	Digital ground input for digital circuits.

Note: Analog circuits are quite sensitive to power and ground noise. PCB layout must take care the power routing and the ground plane. For detailed information, please refer to **GL850 Design Guideline**.

Notation:

- Type O** Output
- I** Input
- B** Bi-directional
- B/I** Bi-directional, default input
- B/O** Bi-directional, default output
- P** Power / Ground
- A** Analog
- SO** Automatic output low when suspend
- pu** Internal pull up
- pd** Internal pull down
- odpu** Open drain with internal pull up

CHAPTER 4 BLOCK DIAGRAM

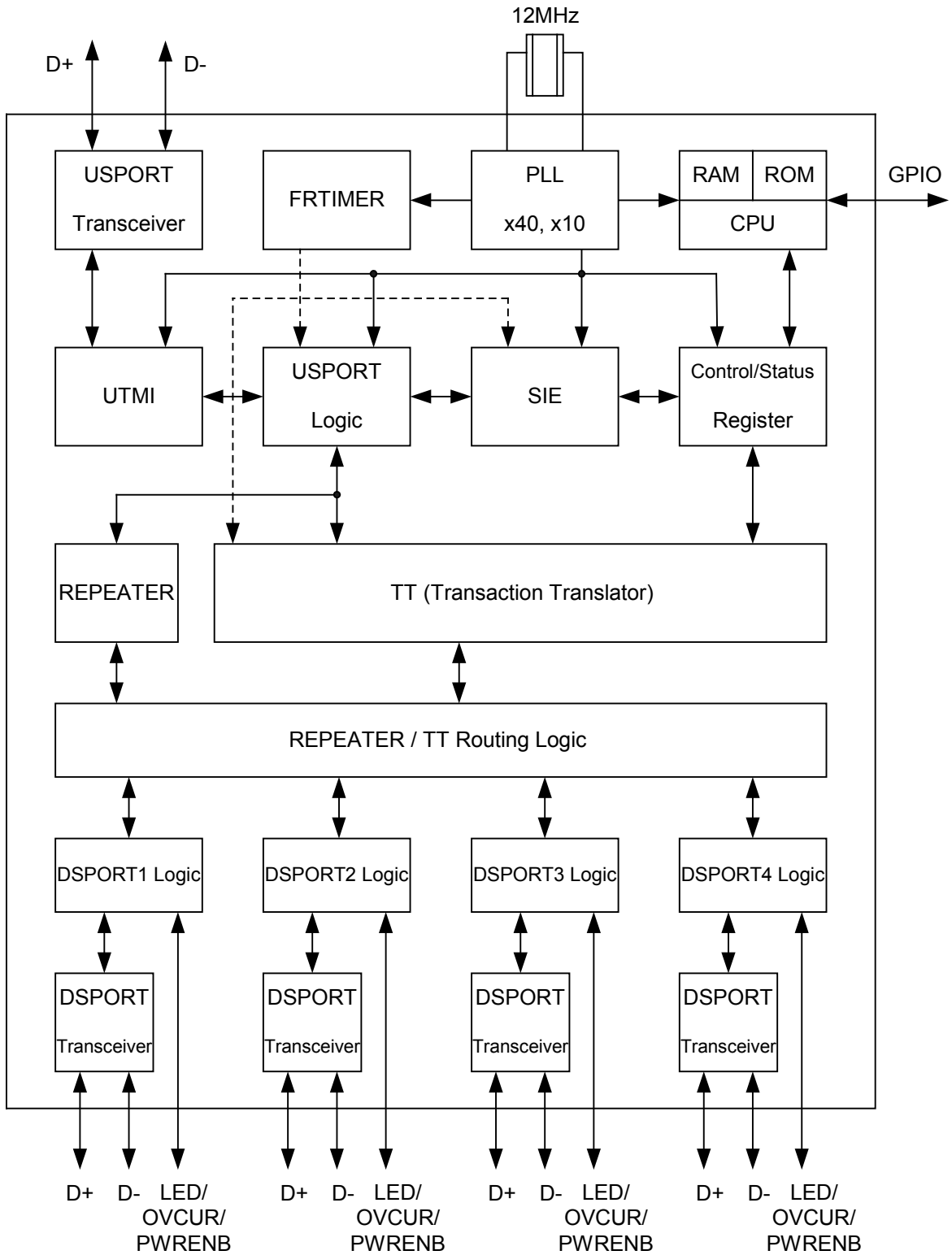

Figure 4.1 - Block Diagram



CHAPTER 5 FUNCTION DESCRIPTION

5.1 General

5.1.1 USPORT Transceiver

USPORT (upstream port) transceiver is the analog circuit that supports both full-speed and high-speed electrical characteristics defined in chapter 7 of *USB specification Revision 2.0*. USPORT transceiver will operate in full-speed electrical signaling when GL850 is plugged into a 1.1 host/hub. USPORT transceiver will operate in high-speed electrical signaling when GL850 is plugged into a 2.0 host/hub.

5.1.2 PLL (Phase Lock Loop)

GL850 contains a 40x PLL and a 10x PLL. PLL generates the clock sources for the whole chip. The generated clocks are proven quite accurate that help in generating high speed signal without jitter.

5.1.3 FRTIMER

This module implements hub (micro)frame timer. The (micro)frame timer is derived from the hub's local clock and is synchronized to the host (micro)frame period by the host generated Start of (micro)frame (SOF). FRTIMER keeps tracking the host's SOF such that GL850 is always safely synchronized to the host. The functionality of FRTIMER is described in section 11.2 of *USB Specification Revision 2.0*.

5.1.4 μC

μC is the micro-processor unit of GL850. It is an 8-bit RISC processor with 2K ROM and 64 bytes RAM. It operates at 6MIPS of 12Mhz clock to decode the USB command issued from host and then prepares the data to respond to the host. In addition, μC can handle GPIO (general purpose I/O) settings and reading content of EEPROM to support high flexibility for customers of different configurations of hub. These configurations include self/bus power mode setting, individual/gang mode setting, downstream port number setting, device removable/non-removable setting, and PID/VID setting.

5.1.5 UTM (USB2.0 Transceiver Macrocell Interface)

UTMI handles the low level USB protocol and signaling. It's designed based on the Intel's UTMI specification 1.01. The major functions of UTMI logic are to handle the data and clock recovery, NRZI encoding/decoding, Bit stuffing /de-stuffing, supporting USB2.0 test modes, and serial/parallel conversion.

5.1.6 USPORT logic

USPORT implements the upstream port logic defined in section 11.6 of *USB specification Revision 2.0*. It mainly manipulates traffics in the upstream direction. The main functions include the state machines of Receiver and Transmitter, interfaces between UTMI and SIE, and traffic control to/from the REPEATER and TT.

5.1.7 SIE (Serial Interface Engine)

SIE handles the USB protocol defined in chapter 8 of *USB specification Revision 2.0*. It co-works with μC to play the role of the hub kernel. The main functions of SIE include the state machine of USB protocol flow, CRC check, PID error check, and timeout check. Unlike USB1.1, bit stuffing/de-stuffing is implemented in UTMI, not in SIE.

5.1.8 Control/Status register

Control/Status register is the interface register between hardware and firmware. This register contains the information necessary to control endpoint0 and endpoint1 pipelines. Through the firmware based architecture, GL850 possesses higher flexibility to control the USB protocol easily and correctly.

5.1.9 REPEATER

Repeater logic implements the control logic defined in section 11.4 and section 11.7 of *USB specification Revision 2.0*. REPEATER controls the traffic flow when upstream port and downstream port are signaling in the same speed. In addition, REPEATER will generate internal resume signal whenever a wakeup event is issued under the situation that hub is globally suspended.

5.1.10 TT (Transaction Translator)

TT implements the control logic defined in section 11.14 ~ 11.22 of *USB specification Revision 2.0*. TT basically handles the unbalanced traffic speed between the USPORT (operating in HS) and DSPORTS (operating in FS/LS) of hub. GL850 adopts the single TT architecture to provide the most cost effective solution. Single TT shares the same buffer control module for each downstream port.

5.1.11 REPEATER/TT routing logic

REPEATER and TT are the major traffic control machines in the USB2.0 hub. Under situation that USPORT and DSPORT are signaling in the same speed, REPEATER/TT routing logic switches the traffic channel to the REPEATER. Under situation that USPORT is in the high speed signaling and DSPORT is in the full/low speed signaling, REPEATER/TT routing logic switches the traffic channel to the TT.

5.1.11.1 Connected to 1.1 Host/Hub

If an USB2.0 hub is connected to the downstream port of an USB1.1 host/hub, it will operate in USB1.1 mode. For an USB1.1 hub, both upstream direction traffic and downstream direction traffic are passing through REPEATER. That is, the REPEATER/TT routing logic will route the traffic channel to the REPEATER.

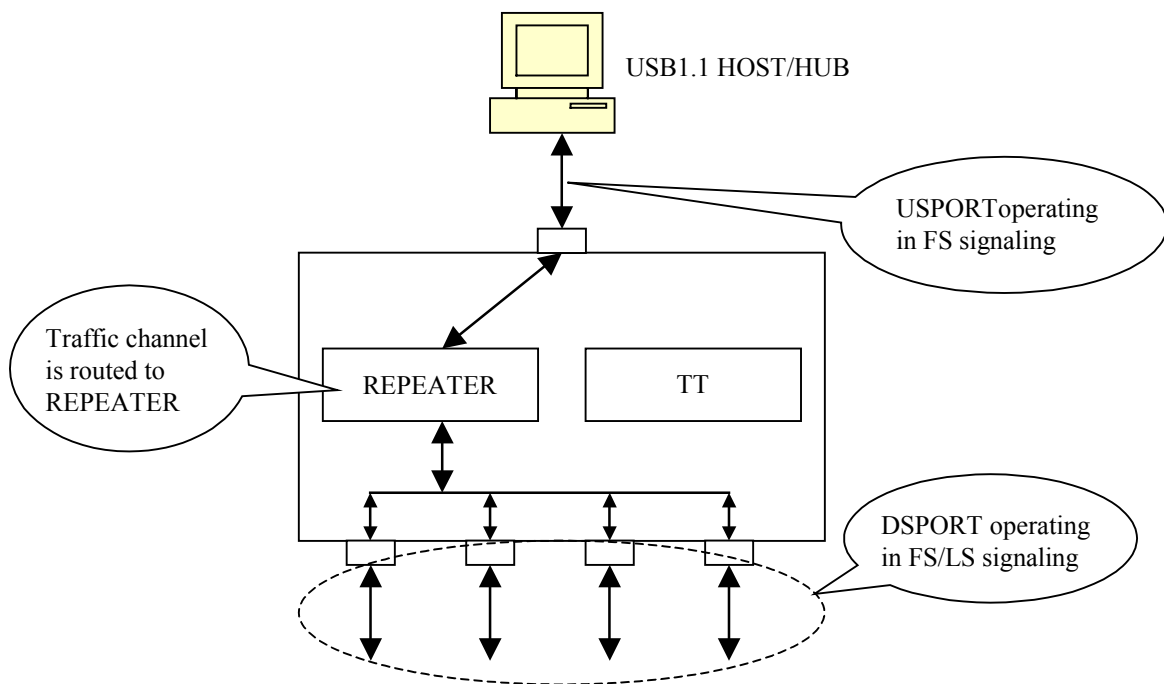

Figure 5.1 - Operating in USB1.1 scheme

5.1.11.2 Connected to USB2.0 Host/Hub

If an USB2.0 hub is connected to an USB2.0 host/hub, it will operate in USB2.0 mode. The upstream port signaling is in high speed with bandwidth of 480 Mbps under this environment. The traffic channel will then be routed to the REPEATER when the device connected to the downstream port is signaling also in high speed. On the other hand, the traffic channel will then be routed to TT when the device connected to the downstream port is signaling in full/low speed.

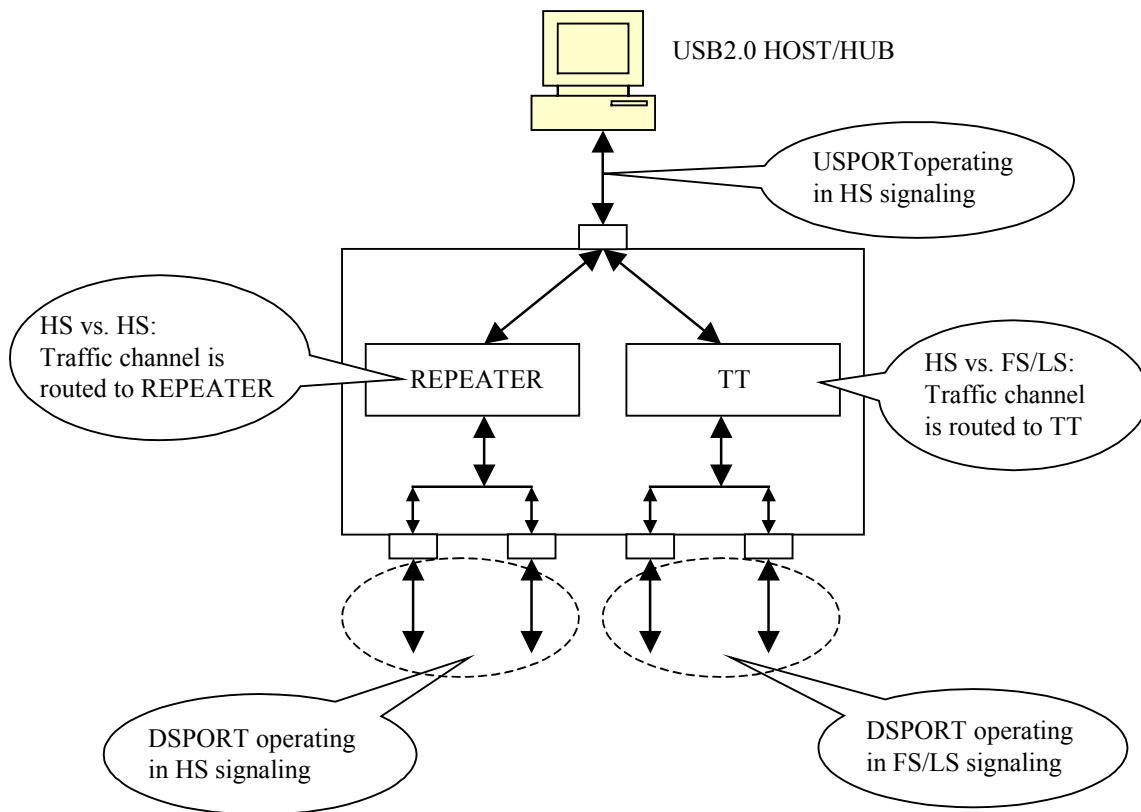

Figure 5.2 - Operating in USB2.0 scheme

5.1.12 DSPORT logic

DSPORT (downstream port) logic implements the control logic defined in section 11.5 of *USB specification Revision 2.0*. It mainly manipulates the state machine, the connection/disconnection detection, over current detection and power enable control, and the status LED control of the downstream port. Besides, it also output the control signals to the DSPORT transceiver.

5.1.13 DSPORT Transceiver

DSPORT transceiver is the analog circuit that supports high-speed, full-speed, and low-speed electrical characteristics defined in chapter 7 of *USB specification Revision 2.0*. In addition, each DSPORT transceiver accurately controls its own squelch level to detect the detachment and attachment of devices.

5.2 Configuration and I/O Settings

5.2.1 RESET# Setting

When RESET# is low enabled, the whole chip is put in initial state. In addition, RPU will disable the pull-up 1.5KΩ resistor to 3.3V, which causes GL850 seems to be disconnected to the host. We suggest configure RESET# as following figure. Vbus is the 5V input from USB cable. GL850 will always be in disconnected state when USB cable is not plugged into host, even that GL850 is powered.

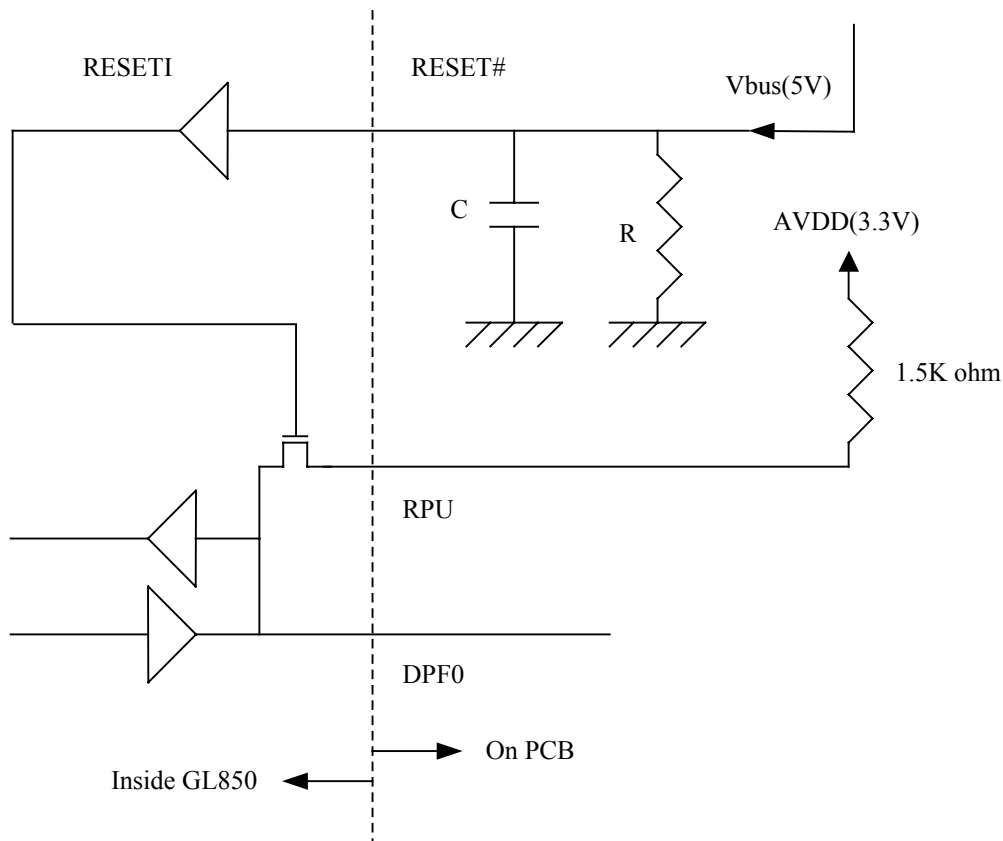

Figure 5.3 - RESET# (External Reset) setting and application

GL850 internally contains a power on reset circuit. The power on sequence is depicted in the next picture. To fully control the reset process of GL850, we suggest the reset time applied in the external reset circuit should more than that of the internal reset circuit.

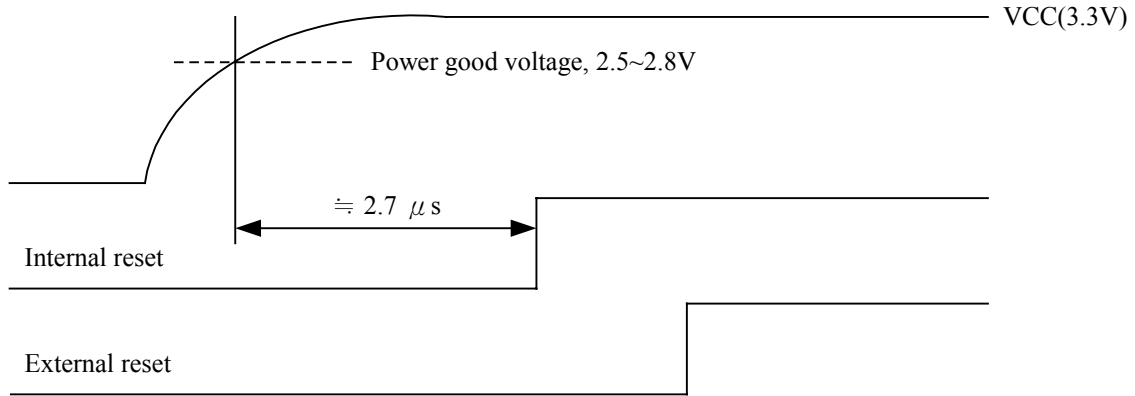

Figure 5.4 - Power on sequence of GL850

5.2.2 PGANG/SUSPND Setting

To save pin count, GL850 uses the same pin to decide individual/gang mode as well as to output the suspend flag. The individual/gang mode is decided in the period of 1ms after power on reset. After that period of time, this pin is changed to output mode. GL850 outputs the suspend flag once it is globally suspended. For individual mode, a pull low resistor greater than 100KΩ should be placed. For gang mode, a pull high resistor greater than 100KΩ should be placed. In figure 5.6, we also depict the suspend LED indicator schematics. It should be noticed that the polarity of LED must be followed, otherwise the suspend current will be over than the current limitation (2.5mA).

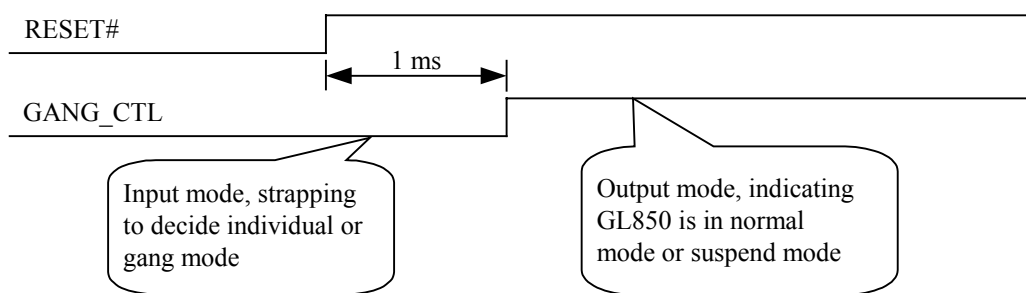

Figure 5.5 - Timing of PGANG/SUSPND strapping

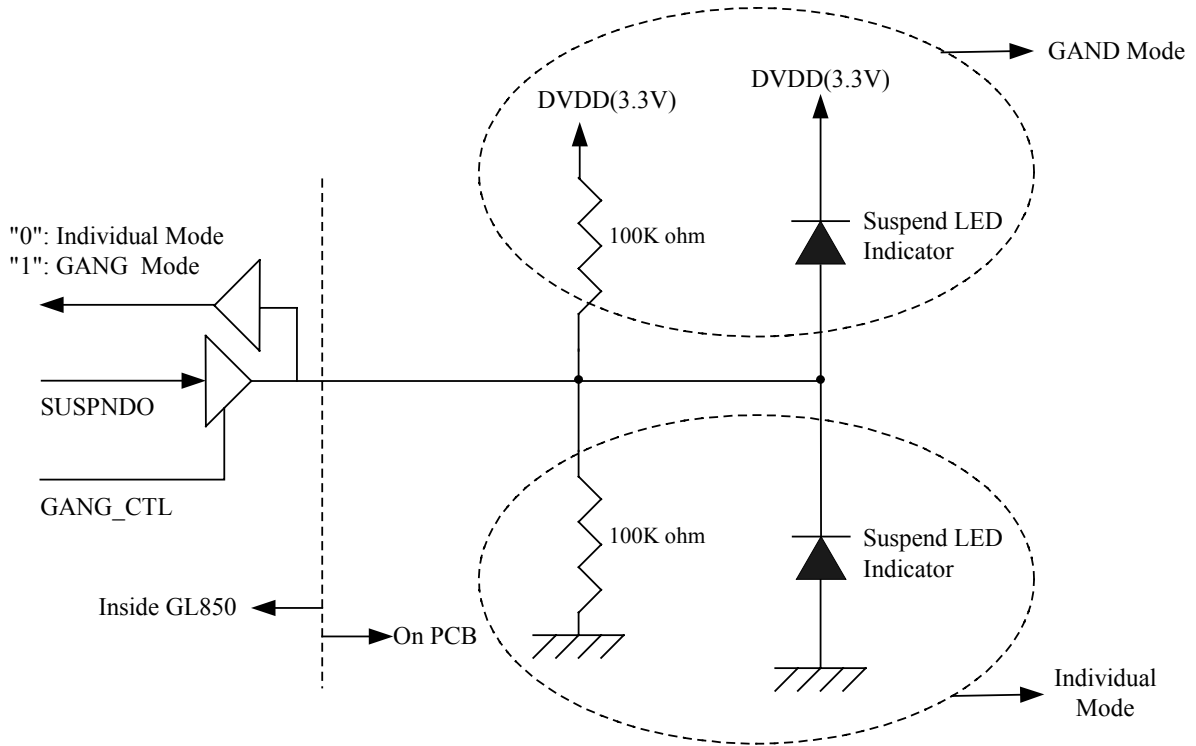

Figure 5.6 - GANG Mode Setting

5.2.3 SELF/BUS Power Setting

GL850 can operate under bus power and conform to the power consumption limitation completely (suspend current < 2.5 mA, normal operation current < 100 mA). By setting PSELF, GL850 can be configured as a bus-power or a self-power hub.

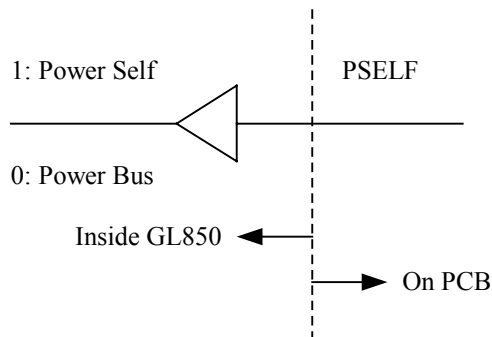

Figure 5.7 - SELF/BUS Power Setting

5.2.4 LED Connections

GL850 controls the LED lighting according to the flow defined in section 11.5.3 of *Universal Serial Bus Specification Revision 2.0*. Both manual mode and Automatic mode are supported in GL850. When GL850 is globally suspended, GL850 will turn off the LED to save power.

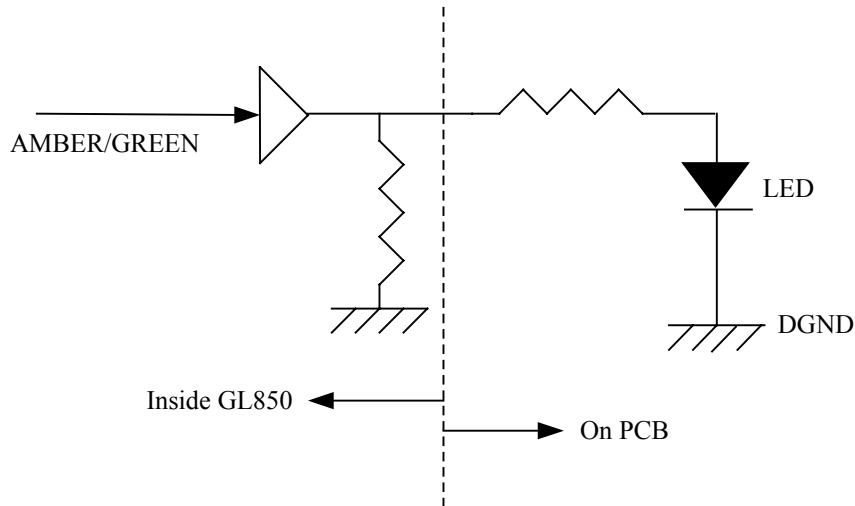

Figure 5.8 - LED Connection

5.2.5 EEPROM Setting

GL850 replies to host commands by the default settings in the internal ROM. GL850 also offers the ability to reply to the host according to the settings in the external EEPROM(93C46). The following table shows the configuration of 93C46.

Table 5.1 - 93C46 Configuration

	00h		01h		02h		03h		04h	05h	06h	07h
00	VID_H	VID_L	PID_H	PID_L	CHKSUM	FF	PORT_NO	DEVICE REMOVABLE	FF	FF	FF	FF
08	VENDOR LENGTH	XX	XX	XX	XX	XX	XX	XX	XX	XX	XX	XX
10	XX	XX	XX	XX	XX	XX	XX	XX	XX	XX	XX	XX
18	XX	XX	XX	XX	XX	XX	XX	XX	XX	XX	XX	XX
20	PRODUCT LENGTH	XX	XX	XX	XX	XX	XX	XX	XX	XX	XX	XX
28	XX	XX	XX	XX	XX	XX	XX	XX	XX	XX	XX	XX
30	XX	XX	XX	XX	XX	XX	XX	XX	XX	XX	XX	XX
38	SERIAL NUMBER LENGTH	XX	XX	XX	XX	XX	XX	XX	XX	XX	XX	XX
40	XX	XX	XX	XX	XX	XX	XX	XX	XX	XX	XX	XX
48	XX	XX	XX	XX	XX	XX	XX	XX	XX	XX	XX	XX

Note: 1. VID_H/VID_L: high/low byte of VID value
 2. PID_H/PID_L: high/low byte of PID value
 3. CHKSUM: CHKSUM must equal to VID_H + VID_L + PID_H + PID_L + 1, otherwise firmware will ignore the EEPROM settings.

4. PORT_NO: port number, value must be 1~4.

5. DEVICE_REMOVEABLE:

-	-	-	PORT4 REMOVABLE	PORT3 REMOVABLE	PORT2 REMOVABLE	PORT1 REMOVABLE	-
---	---	---	--------------------	--------------------	--------------------	--------------------	---

0: Device attached to this port is removable.

1: Device attached to this port is non-removable.

6. VENDOR_LENGTH: offset 08h contains the length of the vendor string. Values of vendor string is contained from 09h~1fh.

7. PRODUCT_LENGTH: offset 20h contains the length of product string. Values of product string is contained from 21h~37h.

8. SERIAL_NUMBER_LENGTH: offset 38h contains the value of serial number string. Values of serial number string is contained after offset 39h.

The schematics between GL850 and 93C46 is depicted in the following figures:

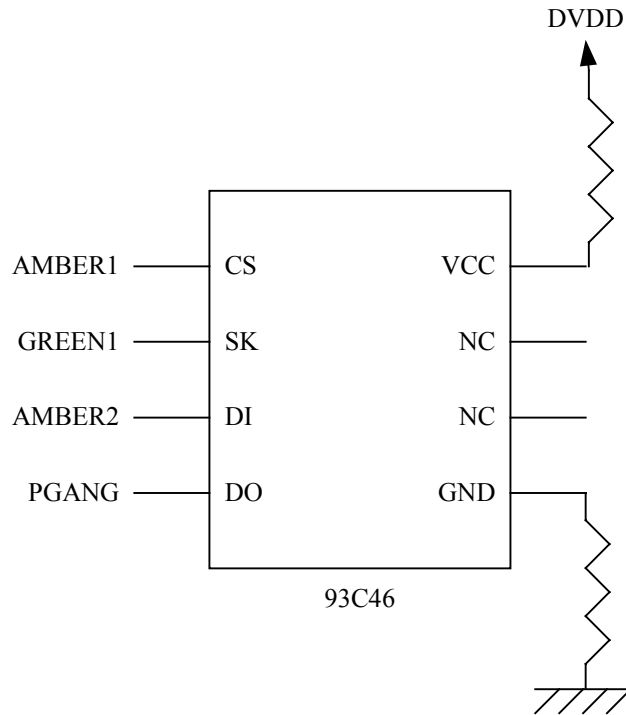

Figure 5.9 - Schematics Between GL850 and 93C46

GL850 firstly verifies the check sum after power on reset. If the check sum is correct, GL850 will take the configuration of 93C46 as part of the descriptor contents. To prevent the content of 93C46 from being over-written, amber LED will be disabled when 93C46 exists.

5.3 USB Protocols

To behave as a standard USB2.0 hub, some protocols defined in Chapter 9 and Chapter 11 of *Universal Serial Bus Specification Revision 2.0* must be followed. We firstly classify these standard requests and hub class requests in section 6.1. Descriptors are described in section 6.2, which contain the detailed information for the hub.



5.3.1 Host Commands and Hub Answers

An USB hub needs at least 2 endpoints to guarantee the normal operation. Endpoint 0 is the default control pipe. Endpoint 1 is the interrupt pipe.

Host gets all the information about the hub and through the control pipe. Hub information like self/bus power and gang/individual mode is all replied to host via endpoint0. Interrupt pipe is to report to the host the updated change of hub status (power change and over current change, for example) and the updated status change of all downstream ports (connect change, suspend change, over current change, etc.).

5.3.1.1 Standard Requests

Table 5.2 - Standard Request List

Request	bmRequestType	bRequest	wValue	wIndex	wLength	Return
GET_DESCRIPTOR (Device)	1000000b	06h	0100h	0000h	0012h	Device Descriptor (Note1)
GET_DESCRIPTOR (Device Qualifier)	1000000b	06h	0600h	0000h	000Ah	Device_Qualifier Descriptor (Note1)
GET_DESCRIPTOR (Configuration)	1000000b	06h	0200h	0000h	0019h	Configuration+Interface+Endpoint Descriptors (Note1)
GET_DESCRIPTOR (Other_Speed_Configuration)	1000000b	06h	0700h	0000h	0019h	Other_Speed_Configuration+Interface+Endpoint Descriptors (Note1)
GET_DESCRIPTOR (String Index0)	1000000h	06h	0300h	0000h	0004h	String Descriptor Index0 (Note1)
GET_DESCRIPTOR (String Index1)	1000000h	06h	0301h	0409h	0020h	String Descriptor Index1 (Note1)
GET_DESCRIPTOR (String Index2)	1000000h	06h	0302h	0409h	002Ch	String Descriptor Index2 (Note1)
SET_ADDRESS	0000000b	05h	0000h ~ 007Fh	0000h	0000h	Zero length packet
SET_CONFIGURATION	0000000b	09h	0000h/0001h	0000h	0000h	Zero length packet
GET_CONFIGURATION	0000000b	08h	0000h	0000h	0001h	Configuration value
SET_INTERFACE	00000001b	0Bh	0000h	0000h	0000h	Zero length packet
SET_FEATURE (Remote wakeup ability)	0000000b	03h	0001h	0000h	0000h	Zero length packet
SET_FEATURE (Endpoint0 halt) no support	00000010b	03h	0000h	0000h/0080h	0000h	Zero length packet
SET_FEATURE (Endpoint1 halt)	00000010b	03h	0000h	0081h	0000h	Zero length packet
CLEAR_FEATURE (Remote wakeup ability)	0000000b	01h	0001h	0000h	0000h	Zero length packet
CLEAR_FEATURE (Endpoint0 halt) no support	00000010b	01h	0000h	0000h/0080h	0000h	Zero length packet



CLEAR_FEATURE (Endpoint1 halt)	00000010b	01h	0000h	0081h	0000h	Zero length packet
GET_INTERFACE	10000001b	0Ah	0000h	0000h	0001h	00h
GET_STATUS (Device)	10000000b	00h	0000h	0000h	0002h	Device status
GET_STATUS (Interface)	10000001b	00h	0000h	0000h	0002h	0000h
GET_STATUS (Endpoint0) no support	10000010b	00h	0000h	0000h/ 0080h	0002h	Endpoint0 status
GET_STATUS (Endpoint1)	10000010b	00h	0000h	0081h	0002h	Endpoint1 status
SET_FEATURE (Test J)	00000000b	03h	0002h	0100h	0000h	Zero length packet
SET_FEATURE (Test K)	00000000b	03h	0002h	0200h	0000h	Zero length packet
SET_FEATURE (Test SE0 NAK)	00000000b	03h	0002h	0300h	0000h	Zero length packet
SET_FEATURE (Test Packet)	00000000b	03h	0002h	0400h	0000h	Zero length packet
SET_FEATURE (Test Force Enable)	00000000b	03h	0002h	0500h	0000h	Zero length packet

Note: 1. The detailed information for these descriptors is described in Section 6.2.

5.3.1.2 Hub Class Requests

Table 5.3 - Hub Class Requests List

Request	bmRequestType	bRequest	wValue	wIndex	wLength	Return
GetHubDescriptor	10100000b	06h	2900h	0000h	0009h	Hub Descriptor (Note1)
GetHubStatus	10100000b	00h	0000h	0000h	0004h	Hub status and change status
GetPortStatus	10100011b	00h	0000h	0001h~ 0004h	0004h	Port status and port change status
SetPortFeature (PORT_RESET)	00100011b	03h	0004h	0001h~ 0004h	0000h	Zero length packet
SetPortFeature (PORT_SUSPEND)	00100011b	03h	0002h	0001h~ 0004h	0000h	Zero length packet
SetPortFeature (PORT_POWER)	00100011b	03h	0008h	0001h~ 0004h	0000h	Zero length packet
ClearHubFeature (C_HUB_OVER_CUR RENT)	00100000b	01h	0001h	0000h	0000h	Zero length packet
ClearPortFeature (PORT_ENABLE)	00100011b	01h	0001h	0001h~ 0004H	0000h	Zero length packet
ClearPortFeature (PORT_SUSPEND)	00100011b	01h	0002h	0001h~ 0004H	0000h	Zero length packet
ClearPortFeature (PORT_POWER)	00100011b	01h	0008h	0001h~ 0004H	0000h	Zero length packet
ClearPortFeature (PORT_INDICATOR)	00100011b	01h	0016h	(Note2)	0000h	Zero length packet



ClearPortFeature (C_PORT_CONNECTI ON)	00100011b	01h	0010h	0001h~ 0004h	0000h	Zero length packet
ClearPortFeature (C_PORT_RESET)	00100011b	01h	0014h	0001h~ 0004h	0000h	Zero length packet
ClearPortFeature (C_PORT_ENABLE)	00100011b	01h	0011h	0001h~ 0004h	0000h	Zero length packet
ClearPortFeature (C_PORT_SUSPEND)	00100011b	01h	0012h	0001h~ 0004h	0000h	Zero length packet
ClearPortFeature (C_PORT_OVER_CU RRENT)	00100011b	01h	0013h	0001h~ 0004h	0000h	Zero length packet
SetPortFeature (PORT_TEST:TEST_J)	00100011b	03h	0015h	0101h~ 0104h	0000h	Zero length packet
SetPortFeature (PORT_TEST:TEST_K)	00100011b	03h	0015h	0201h~ 0204h	0000h	Zero length packet
SetPortFeature (PORT_TEST: TEST_SE0_NAK)	00100011b	03h	0015h	0301h~ 0304h	0000h	Zero length packet
SetPortFeature (PORT_TEST: TEST_PACKET)	00100011b	03h	0015h	0401h~ 0404h	0000h	Zero length packet
SetPortFeature (PORT_TEST: TEST_FORCE_ENAB LE)	00100011b	03h	0015h	0501h~ 0504h	0000h	Zero length packet
SetPortFeature (PORT_INDICATOR)	00100011b	03h	0016h	(Note2)	0000h	Zero length packet
ClearTTBuffer	00100011b	08h	(Note3)	0001h	0000h	Zero length packet
GetTTStatus	10100011B	0Ah	0000h	0001h	08D0h?	TT state
ResetTT	00100011b	09h	0000h	0001h	0000h	Zero length packet
StopTT	00100011B	0Bh	0000h	0001h	0000h	Zero length packet

Note: 1. Hub descriptor is described in Section 6.2.

2. High byte of wIndex is the port indicators selector code, low byte of wIndex is the port number. For detailed information, please refer to the section 11.24.2.13 of *Universal Serial Bus Specification Revision 2.0*.

3. The device address, endpoint number, and endpoint type of the full-/low-speed endpoint that may have a busy TT buffer must be specified in the wValue field. For detailed information, please refer to the table 11-18 of section 11.24.2.3 of *Universal Serial Bus Specification Revision 2.0*.



5.4 Descriptors

Descriptors contain all the information about the USB2.0 hub. Host asks different types of descriptors by different GET_DESCRIPTOR commands. Hub will reply to different GET_DESCRIPTOR the associated descriptors to let host know how to configure the hub. For an USB2.0 hub, the descriptors are:

- Device Descriptor
- Device Qualifier Descriptor
- Configuration Descriptor
- Interface Descriptor
- Endpoint Descriptor
- Other Speed Configuration Descriptor
- Hub Class-specific Descriptor
- String Descriptor

Descriptors replied are different between full speed and high speed for an USB2.0 hub. Once an USB2.0 hub is plugged into a host/hub, it needs to firstly decide the host/hub is an USB1.1 host/hub or an USB2.0 host/hub. If the host/hub being plugged is an USB1.1 hub, GL850 replies to the host the full speed descriptors defined in section 6.2.1. Otherwise, GL850 replies the high speed descriptors defined in section 6.2.2. For hub class-specific descriptor, there's no difference between full speed and high speed.

5.4.1 Full Speed Case

5.4.1.1 Device Descriptor

Hub returns Device Descriptor when GET_DESCRIPTOR (DEVICE) command is requested.

Table 5.4 - Device Descriptor for Full Speed

Offset	Field	Value	Description	I/O Configuration	EEPROM Configuration
0	bLength	12h	18 bytes for this descriptor	-	-
1	bDescriptorType	01h	Device descriptor type	-	-
2	bcdUSB	0200h	USB2.0 compliance	-	-
4	bDeviceClass	09h	Hub class code	-	-
5	bDeviceSubClass	00h	Subclass code	-	-
6	bDeviceProtocol	00h	Protocol code	-	-
7	bMaxPacketSize0	40h	Max. packet size of endpoint0	-	-
8	idVendor	05E3h	Vendor ID of Genesys Logic Inc.	-	Y
10	idProduct	0660h	Product ID of Genesys Logic Inc.	-	Y
12	bcdDevice	xxxxh	Version Control	-	Y
14	iManufacturer	00h	Index of vendor string	-	Y
15	idProduct	01h	Index of product string	-	Y
16	iSerialNumber	00h	Index of serial number	-	Y
17	bNumConfigurations	01h	Number of configuration	-	-

5.4.1.2 Device Qualifier Descriptor

Hub returns Device Qualifier Descriptor when GET_DESCRIPTOR (DEVICE_QUALIFIER) command is issued from host.

Table 5.5 - Device Qualifier for Full Speed

Offset	Field	Value	Description	I/O Configuration	EEPROM Configuration
0	bLength	0Ah	10 bytes for this descriptor	-	-
1	bDescriptorType	06h	Device qualifier descriptor type	-	-
2	bcdUSB	0200h	USB2.0 compliance	-	-
4	bDeviceClass	09h	Hub class code	-	-
5	bDeviceSubClass	00h	Subclass code	-	-
6	bDeviceProtocol	01h	Single TT	-	-
7	bMaxPacketSize0	40h	Max. packet size for endpoint0 of other speed	-	-
8	bNumConfigurations	01h	Number of other speed config.	-	-
9	bReserved	00h	Reserved for future use	-	-

5.4.1.3 Configuration Descriptor

When host issues GET_DESCRIPTOR (CONFIGURATION) command to the hub, hub will return Configuration Descriptor, Interface Descriptor, and Endpoint Descriptor in combination to the host.

Table 5.6 - Configuration Descriptor for Full Speed

Offset	Field	Value	Description	I/O Configuration	EEPROM Configuration
0	bLength	09h	9 bytes for this descriptor	-	-
1	bDescriptorType	02h	Configuration descriptor type	-	-
2	wTotalLength	0019h	Total 25 bytes	-	-
4	bNumberInterface	01h	Number of interfaces	-	-
5	bConfigurationValue	01h	Configuration value	-	-
6	iConfiguration	00h	Index of string descriptor	-	-
7	bmAttribute	E0h	Can switch between self power and bus power	-	-
8	bMaxPower	32h	Max. power = 100 mA	-	-

5.4.1.4 Interface Descriptor

Interface Descriptor follows Configuration Descriptor for GET_DESCRIPTOR (CONFIGURATION) command.

Table 5.7 - Interface Descriptor for Full Speed

Offset	Field	Value	Description	I/O Configuration	EEPROM Configuration
0	bLength	09h	9 bytes for this descriptor	-	-
1	bDescriptorType	04h	Interface descriptor type	-	-
2	bInterfaceNumber	00h	Interface number	-	-
3	bAlternateSetting	00h	Alternate setting	-	-
4	bNumEndpoints	01h	Number of endpoints	-	-
5	bInterfaceClass	09h	Hub class code	-	-
6	bInterfaceSubClass	00h	Subclass code	-	-
7	bInterfaceProtocol	00h	Protocol code	-	-
8	iInterface	00h	Index of string descriptor	-	-

5.4.1.5 Endpoint Descriptor

Endpoint Descriptor follows Interface Descriptor for GET_DESCRIPTOR (CONFIGURATION) command.

Table 5.8 - Endpoint Descriptor for Full Speed

Offset	Field	Value	Description	I/O Configuration	EEPROM Configuration
0	bLength	07h	7bytes for this descriptor	-	-
1	bDescriptorType	05h	Endpoint descriptor type	-	-
2	bEpointAddress	81h	Address of the endpoint	-	-
3	bAttribute	03h	Interrupt endpoint	-	-
4	wMaxPacketSize	0001h	Max. packet size of the endpoint	-	-
6	bInterval	ffh	Polling interval (ms)	-	-



5.4.1.6 Other Speed Configuration Descriptor

An USB2.0 hub returns Other Speed Configuration Descriptor for the command GET_DESCRIPTOR (OTHER_SPEED_CONFIGURATION). An USB2.0 host will issue this command when the hub plugged is an USB2.0 hub.

Table 5.9 - Other Speed Configuration Descriptor for Full Speed

Offset	Field	Value	Description	I/O Configuration	EEPROM Configuration
0	bLength	09h	9 bytes for this descriptor	-	-
1	bDescriptorType	07h	Other speed descriptor type	-	-
2	wTotalLength	19h	Total 25 bytes	-	-
4	bNumberInterface	01h	Number of interfaces	-	-
5	bConfigurationValue	01h	Configuration value	-	-
6	iConfiguration	00h	Index of string descriptor	-	-
7	bmAttribute	E0h	Can switch between self power and bus power	-	-
8	bMaxPower	32h	Max. power = 100 mA	-	-

5.4.1.7 Interface Descriptor combined with Other Speed Configuration Descriptor

Other Speed Interface Descriptor is in combination after Other Speed Configuration Descriptor for the command GET_DESCRIPTOR (OTHER_SPEED_CONFIGURATION).

Table 5.10 - Other Speed Interface Descriptor for Full Speed

Offset	Field	Value	Description	I/O Configuration	EEPROM Configuration
0	bLength	09h	9 bytes for this descriptor	-	-
1	bDescriptorType	04h	Interface descriptor type	-	-
2	bInterfaceNumber	00h	Interface number	-	-
3	bAlternateSetting	00h	Alternate setting	-	-
4	bNumEndpoints	01h	Number of endpoints	-	-
5	bInterfaceClass	09h	Hub class code	-	-
6	bInterfaceSubClass	00h	Subclass code	-	-
7	bInterfaceProtocol	00h	Single TT	-	-
8	iInterface	00h	Index of string descriptor	-	-

5.4.1.8 Endpoint Descriptor combined with Other Speed Configuration Descriptor

Other Speed Endpoint Descriptor is in combination after Other Speed Interface Descriptor for the command GET_DESCRIPTOR (OTHER_SPEED_CONFIGURATION).

Table 5.11 - Other Speed Endpoint Descriptor for Full Speed

Offset	Field	Value	Description	I/O Configuration	EEPROM Configuration
0	bLength	07h	7bytes for this descriptor	-	-
1	bDescriptorType	05h	Endpoint descriptor type	-	-
2	bEpointAddress	81h	Address of the endpoint	-	-
3	bAttribute	03h	Interrupt endpoint	-	-
4	wMaxPacketSize	0001h	Max. packet size of the endpoint	-	-
6	bInterval	0Ch	Polling interval = $(2^{12}-1) \times 125 \text{ us}$	-	-

5.4.1.9 String Descriptor

String Descriptor is replied for the command GET_DESCRIPTOR (STRING). Generally, one string contains the information for manufacturer and the other contains the information for the product. These strings can be configured in EERPOM. GL850 will read the data in the EEPROM to respond to the host. The information in the following table are the default settings of Genesys Logic Inc.

Table 5.12 - String Index0 for Full Speed

Offset	Field	Value	Description	I/O Configuration	EEPROM Configuration
0	bLength	04h	4 bytes for this descriptor	-	-
1	bDescriptorType	03h	String descriptor type	-	-
2	wLangid	0409	Language : English	-	-

Table 5.13 - String Index1 for Full Speed

Offset	Field	Value	Description	I/O Configuration	EEPROM Configuration
0	bLength	16h	16 bytes for this descriptor	-	Y
1	bDescriptorType	03h	String descriptor type	-	Y
2	bString	Unicode encoded manufacture string-USB2.0 Hub as default setting		-	Y



Table 5.14 - String Index2 for Full Speed

Offset	Field	Value	Description	I/O Configuration	EEPROM Configuration
0	bLength	xxh	x bytes for this descriptor	-	Y
1	bDescriptorType	03h	String descriptor type	-	Y
2	bString	Unicode encoded product string – No default setting		-	Y

5.4.2 High Speed Case

5.4.2.1 Device Descriptor

High Speed Device Descriptor is replied when hub is operated in high speed mode. The content of high speed Device Descriptor is almost the same as Full Speed Device Descriptor, except the bDeviceProtocol value is 01h, which means GL850 is a single TT hub.

Table 5.15 - Device Descriptor for High Speed

Offset	Field	Value	Description	I/O Configuration	EEPROM Configuration
0	bLength	12h	18 bytes for this descriptor	-	-
1	bDescriptorType	01h	Device descriptor type	-	-
2	bcdUSB	0200h	USB2.0 compliance	-	-
4	bDeviceClass	09h	Hub class code		-
5	bDeviceSubClass	00h	Subclass code		-
6	bDeviceProtocol	01h	Single TT		-
7	bMaxPacketSize0	40h	Max. packet size of endpoint0		-
8	idVendor	05E3h	Vendor ID of Genesys Logic Inc.		Y
10	idProduct	0660h	Product ID of Genesys Logic Inc.		Y
12	bcdDevice	xxxxh	Version Control		Y
14	iManufacturer	00h	Index of vendor string		Y
15	idProduct	01h	Index of product string	-	Y
16	iSerialNumber	00h	Index of serial number	-	Y
17	bNumConfigurations	01h	Number of configuration	-	-

5.4.2.2 Device Qualifier Descriptor

High Speed Device Qualifier Descriptor contains almost the same information as the Full Speed Device Qualifier Descriptor, except that bDeviceProtocol value is 00h.

Table 5.16 - Device Qualifier for High Speed

Offset	Field	Value	Description	I/O Configuration	EEPROM Configuration
0	bLength	0Ah	10 bytes for this descriptor	-	-
1	bDescriptorType	06h	Device qualifier descriptor type	-	-
2	bcdUSB	0200h	USB2.0 compliance	-	-
4	bDeviceClass	09h	Hub class code	-	-
5	bDeviceSubClass	00h	Subclass code	-	-
6	bDeviceProtocol	00h	Protocol code	-	-
7	bMaxPacketSize0	40h	Max. packet size for endpoint0 of other speed	-	-
8	bNumConfigurations	01h	Number of other speed config.	-	-
9	bReserved	00h	Reserved for future use	-	-

5.4.2.3 Configuration Descriptor

Information contained in High Speed Configuration Descriptor is the same as Full Speed Configuration Descriptor.

Table 5.17 - Configuration Descriptor for High Speed

Offset	Field	Value	Description	I/O Configuration	EEPROM Configuration
0	bLength	09h	9 bytes for this descriptor	-	-
1	bDescriptorType	02h	Configuration descriptor type	-	-
2	wTotalLength	0019h	Total 25 bytes	-	-
4	bNumberInterface	01h	Number of interfaces	-	-
5	bConfigurationValue	01h	Configuration value	-	-
6	iConfiguration	00h	Index of string descriptor	-	-
7	bmAttribute	E0h	Can switch between self power and bus power	-	-
8	bMaxPower	32h	Max. power = 100 mA	-	-

5.4.2.4 Interface Descriptor

Interface Descriptor follows Configuration Descriptor for GET_DESCRIPTOR (CONFIGURATION) command.

Table 5.18 - Interface Descriptor for High Speed

Offset	Field	Value	Description	I/O Configuration	EEPROM Configuration
0	bLength	09h	9 bytes for this descriptor	-	-
1	bDescriptorType	04h	Interface descriptor type	-	-
2	bInterfaceNumber	00h	Interface number	-	-
3	bAlternateSetting	00h	Alternate setting	-	-
4	bNumEndpoints	01h	Number of endpoints	-	-
5	bInterfaceClass	09h	Hub class code	-	-
6	bInterfaceSubClass	00h	Subclass code	-	-
7	bInterfaceProtocol	00h	Single TT	-	-
8	iInterface	00h	Index of string descriptor	-	-

5.4.2.5 Endpoint Descriptor in Configuration Descriptor

bInterval of High Speed Interface Descriptor is 0Ch, which is different from that of Full Speed Endpoint Descriptor.

Table 5.19 - Endpoint Descriptor for High Speed

Offset	Field	Value	Description	I/O Configuration	EEPROM Configuration
0	bLength	07h	7bytes for this descriptor	-	-
1	bDescriptorType	05h	Endpoint descriptor type	-	-
2	bEpointAddress	81h	Address of the endpoint	-	-
3	bAttribute	03h	Interrupt endpoint	-	-
4	wMaxPacketSize	01h	Max. packet size of the endpoint	-	-
6	bInterval	0Ch	Polling interval = $(2^{12}-1) \times 125 \text{ us}$	-	-

5.4.2.6 Other Speed Configuration Descriptor

Values in all the field of High Speed Other Speed Configuration Descriptor are the same as those of Full Speed Other Speed Configuration Descriptor.

Table 5.20 - Other Speed Configuration Descriptor for High Speed

Offset	Field	Value	Description	I/O Configuration	EEPROM Configuration
0	bLength	09h	9 bytes for this descriptor	-	-
1	bDescriptorType	07h	Other speed descriptor type	-	-
2	wTotalLength	19h	Total 25 bytes	-	-
4	bNumberInterface	01h	Number of interfaces	-	-
5	bConfigurationValue	01h	Configuration value	-	-
6	iConfiguration	00h	Index of string descriptor	-	-
7	bmAttribute	E0h	Can switch between self power and bus power	-	-
8	bMaxPower	32h	Max. power = 100 mA	-	-

5.4.2.7 Interface Descriptor in Other Speed Configuration Descriptor

All the values in this descriptor are the same as those in Other Speed Interface Descriptor for full speed.

Table 5.21 - Other Speed Interface Descriptor for High Speed

Offset	Field	Value	Description	I/O Configuration	EEPROM Configuration
0	bLength	09h	9 bytes for this descriptor	-	-
1	bDescriptorType	04h	Interface descriptor type	-	-
2	bInterfaceNumber	00h	Interface number	-	-
3	bAlternateSetting	00h	Alternate setting	-	-
4	bNumEndpoints	01h	Number of endpoints	-	-
5	bInterfaceClass	09h	Hub class code	-	-
6	bInterfaceSubClass	00h	Subclass code	-	-
7	bInterfaceProtocol	00h	Protocol code	-	-
8	iInterface	00h	Index of string descriptor	-	-

5.4.2.8 Endpoint Descriptor in Other Speed Configuration Descriptor
Table 5.22 - Other Speed Endpoint Descriptor for High Speed

Offset	Field	Value	Description	I/O Configuration	EEPROM Configuration
0	bLength	07h	7bytes for this descriptor	-	-
1	bDescriptorType	05h	Endpoint descriptor type	-	-
2	bEpointAddress	81h	Address of the endpoint	-	-
4	bAttribute	03h	Interrupt endpoint	-	-
5	wMaxPacketSize	01h	Max. packet size of the endpoint	-	-
6	bInterval	FFh	Polling interval (ms)	-	-

5.4.2.9 String Descriptor

All the values of all the String Descriptors for high speed are the same as those for full speed.

Table 5.23 - String Index0 for High Speed

Offset	Field	Value	Description	I/O Configuration	EEPROM Configuration
0	bLength	04h	4 bytes for this descriptor	-	-
1	bDescriptorType	03h	String descriptor type	-	-
2	wLangid	0409	Language : English	-	-

Table 5.24 - String Index1 for High Speed

Offset	Field	Value	Description	I/O Configuration	EEPROM Configuration
0	bLength	16h	16 bytes for this descriptor	-	Y
1	bDescriptorType	03h	String descriptor type	-	Y
2	bString	Unicode encoded manufacture string - USB2.0 Hub as default setting		-	Y

Table 5.25 - String Index2 for High Speed

Offset	Field	Value	Description	I/O Configuration	EEPROM Configuration
0	bLength	XXh	x bytes for this descriptor	-	Y
1	bDescriptorType	03h	String descriptor type	-	Y
2	bString	Unicode encoded product string – No default setting		-	Y



5.4.3 Hub Class Descriptor

Hub Class Descriptor is replied to the host for the GET_DESCRIPTOR (HUB) command. There's no difference in the content for full speed and high speed.

Table 5.26 - Hub Class Descriptor

Offset	Field	Value	Description	I/O Configuration	EEPROM Configuration
0	bLength	09h	9 bytes for this descriptor	-	-
1	bDescriptorType	29h	Hub descriptor type	-	-
2	bNbrPorts	04h	Number of ports	-	-
4	wHubCharacteristics	89h 80h	Individual mode Gang mode	Y	-
5	bPwrOn2PwrGood	32h	Time from power on to power good (2 ms)	-	-
6	bHubContrCurrent	64h	Maximum current (mA)	-	-
7	bDeviceRemoveable	00h	All devices are removable	-	-
8	bPortPwrCtrlMask	FFh	For compatible to USB1.0	-	-



CHAPTER 6 ELECTRICAL CHARACTERISTICS

6.1 Maximum Ratings

Table 6.1 - Maximum Ratings

Symbol	Parameter	Min.	Max.	Unit
V _{CC}	Power Supply	-0.5	+3.6	V
V _{IN}	Input Voltage	-0.5	5	V
V _{OUT}	Output Voltage	-0.5	+3.6	V
T _A	Ambient Temperature under bias	-60	+100	°C
F _{OSC}	Frequency	12 MHz ± 100ppm		

6.2 DC Characteristics

Table 6.2 - DC Characteristics Except USB Signals

Symbol	Parameter	Min.	Typ.	Max.	Unit
P _D	Power Dissipation				mW
V _{DD}	Power Supply Voltage	3	3.3	3.6	V
V _{IL}	LOW level input voltage			0.9	V
V _{IH}	HIGH level input voltage	2.0			V
V _{TLH}	LOW to HIGH threshold voltage	1.36	1.48	1.62	V
V _{THL}	HIGH to LOW threshold voltage	1.36	1.48	1.62	V
V _{OL}	LOW level output voltage when I _{OL} =8mA			0.4	V
V _{OH}	HIGH level output voltage when I _{OH} =8mA	2.4			V
I _{OLK}	Leakage current for pads with internal pull up or pull down resistor			30	μA
R _{DN}	Pad internal pull down resistor	81K	103K	181K	Ω
R _{UP}	Pad internal pull up resistor	81K	103K	181K	Ω

Table 6.3 - DC Characteristics of USB Signals Under FS/LS Mode

Symbol	Parameter	Min.	Typ.	Max.	Unit
V _{OL}	DPF/DMF static output LOW (R _L of 1.5K to 3.6V)			0.3	V
V _{OH}	DPF/DMF static output HIGH (R _L of 15K to GND)	2.8		3.6	V
V _{DI}	Differential input sensitivity	0.2			V
V _{CM}	Differential common mode range	0.8		2.5	V
V _{SE}	Single-ended receiver threshold	0.2			V
C _{IN}	Transceiver capacitance			20	pF
I _{LO}	Hi-Z state data line leakage	-10		+10	μA
Z _{DRV}	Driver output resistance	28		43	Ω



Table 6.4 - DC Characteristics of USB Signals Under HS Mode

Symbol	Parameter	Min.	Typ.	Max.	Unit
V _{IL}	Low-level input voltage with HS termination resistor enabled, Pull-up resistor disconnected				mV
V _{IH}	High-level input voltage with HS termination resistor enabled, Pull-up resistor disconnected				mV
V _{IL}	Low-level input voltage with HS termination resistor enabled, Pull-up resistor connected				mV
V _{IH}	High-level input voltage with HS termination resistor enabled, Pull-up resistor connected				mV
V _{OL}	DPH/DMH static output LOW(R _L of 1.5K to 3.6V)			0.3	V
V _{OH}	DPH/DMH static output HIGH (R _L of 15K to GND)	2.8		3.6	V
C _{IN}	Transceiver capacitance			20	pF
I _{LO}	Hi-Z state data line leakage	-10		+10	μA
Z _{DRV}	Driver output resistance for USB2.0 HS				Ω

CHAPTER 7 PACKAGE DIMENSION

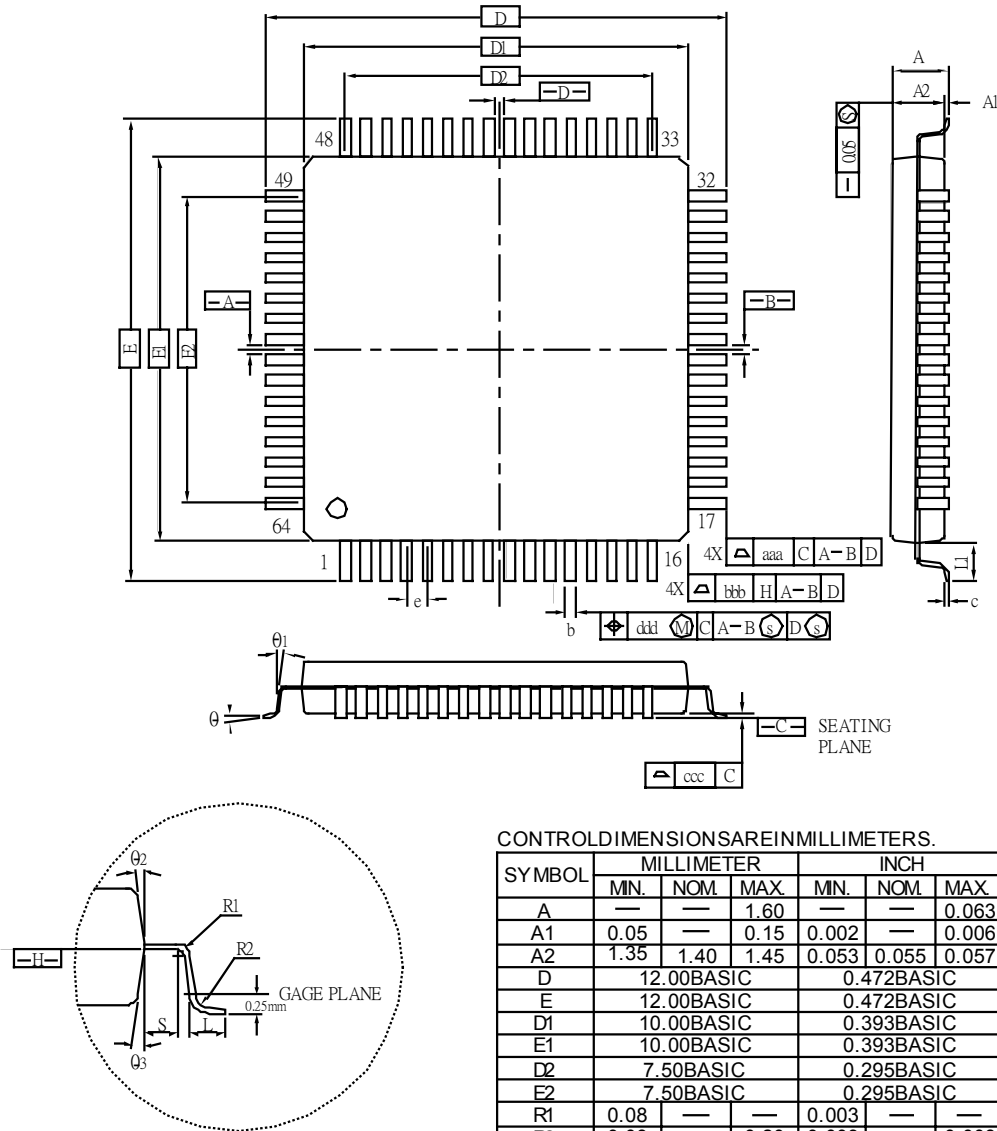

CONTROL DIMENSIONS ARE IN MILLIMETERS.

SYMBOL	MILLIMETER			INCH		
	MIN.	NOM	MAX	MIN.	NOM	MAX
A	—	—	1.60	—	—	0.063
A1	0.05	—	0.15	0.002	—	0.006
A2	1.35	1.40	1.45	0.053	0.055	0.057
D	12.00BASIC			0.472BASIC		
E	12.00BASIC			0.472BASIC		
D1	10.00BASIC			0.393BASIC		
E1	10.00BASIC			0.393BASIC		
D2	7.50BASIC			0.295BASIC		
E2	7.50BASIC			0.295BASIC		
R1	0.08	—	—	0.003	—	—
R2	0.08	—	0.20	0.003	—	0.008
θ	0	3.5	7	0	3.5	7
θ1	0	—	—	0	—	—
θ2	11	12	13	11	12	13
θ3	11	12	13	11	12	13
c	0.09	—	0.20	0.004	—	0.008
L	0.45	0.60	0.75	0.018	0.024	0.030
L1	1.00REF			0.039REF		
S	0.20	—	—	0.008	—	—
b	0.17	0.20	0.27	0.007	0.008	0.011
e	0.50BASIC			0.020BASIC		
TOLERANCES OF FORM AND POSITION						
aaa	0.20			0.008		
bbb	0.20			0.008		
ccc	0.08			0.003		
ddd	0.08			0.003		

NOTES :

- DIMENSIONS D1 AND E1 DO NOT INCLUDE MOLD PROTRUSION. ALLOWABLE PROTRUSION IS 0.25 mm PER SIDE. D1 AND E1 ARE MAXIMUM PLASTIC BODY SIZE DIMENSIONS INCLUDING MOLD MISMATCH.
- DIMENSION b DOES NOT INCLUDE DAMBAR PROTRUSION. ALLOWABLE DAMBAR PROTRUSION SHALL NOT CAUSE THE LEAD WIDTH TO EXCEED THE MAXIMUM b DIMENSION BY MORE THAN 0.08mm. DAMBAR CAN NOT BE LOCATED ON THE LOWER RADIUS OR THE FOOT. MINIMUM SPACE BETWEEN PROTRUSION AND AN ADJACENT LEAD IS 0.07mm.

Figure 7.1 - GL850 64 Pin LQFP Package